

Quasi-one-dimensional spin- $\frac{1}{2}$ Heisenberg magnets in their ordered phase: Correlation functions

Fabian H. L. Essler and Alexei M. Tsvelik

Department of Physics, Theoretical Physics, Oxford University, 1 Keble Road, Oxford OX1 3NP, United Kingdom

Gesualdo Delfino

Laboratoire de Physique Théorique, Université de Montpellier II, Place Eugène Batallion, 34095 Montpellier, France

(Received 21 May 1997)

We study weakly coupled antiferromagnetic spin chains in their ordered phase by combining an exact solution of the single-chain problem with a random-phase-approximation analysis of the interchain interaction. A single chain is described by a quantum Sine-Gordon model and dynamical staggered susceptibilities are determined by employing the form-factor approach to quantum correlation functions. We consider both antiferromagnetic order encountered in quasi-one-dimensional materials such as KCuF_3 and spin-Peierls order as found in CuGeO_3 . [S0163-1829(97)00941-7]

I. INTRODUCTION

The increasing amount of neutron data on quasi-one-dimensional (1D) antiferromagnets calls for creation of a theory capable of describing the behavior of such strongly anisotropic nonlinear systems in greater detail. Of particular interest with regard to recent experiments on CuGeO_3 and KCuF_3 is the structure of the multiparticle continua. In the present paper we discuss correlation functions of three closely related problems involving spin- $\frac{1}{2}$ Heisenberg chains: (i) a single chain with a static alternating exchange, (ii) a single chain in a staggered magnetic field, and (iii) a system of weakly coupled spin- $\frac{1}{2}$ Heisenberg chains at low temperatures in the ordered phase. In the latter case we consider two types of order: (a) spin-Peierls¹⁻⁴ and (b) antiferromagnetic.⁵⁻⁷

An experimental realization of situation (i) may be achieved in $(\text{VO})_2\text{P}_2\text{O}_7$. The analysis of the recent experiments conducted by Garrett *et al.*⁸ indicates that the strongest exchange occurs through alternatively arranged molecules of two different types such that the ratio of the exchange integrals is $J'/J \approx 0.722$.

The second situation (ii) may be realized when a Heisenberg magnet with a staggered Landé factor is placed in an external magnetic field. This is the case for copper benzoate⁹ but for reasons that will be discussed elsewhere the theory presented here does not apply.

The spin-Peierls transition is a magnetoelastic transition which occurs in quasi-1D antiferromagnets due to an effective four-spin interaction. Such interactions may be generated by phonons which modify the exchange integrals; however, the virtual absence of softening of the phonon spectrum in the spin-Peierls material CuGeO_3 (Ref. 10) suggests that there may be also other mechanisms. The interaction between the staggered parts of energy densities is strongly relevant and resolves in dimerization of the lattice at a certain temperature T_c and the formation of spectral gaps in the spectrum of magnetic excitations. In any realistic system phonons are three-dimensional which determines a three-dimensional nature of the spin-Peierls transition. A simple model with a phonon mechanism has the Hamiltonian

$$\begin{aligned}
 H = & J \sum_{\mathbf{r}, n} [1 + (-1)^n u_{n, \mathbf{r}}] \vec{\mathbf{S}}_{n, \mathbf{r}} \cdot \vec{\mathbf{S}}_{n+1, \mathbf{r}} \\
 & + \frac{1}{2} \sum_{n, \mathbf{r}, \mathbf{r}'} u_{n, \mathbf{r}} D(\mathbf{r} - \mathbf{r}') u_{n, \mathbf{r}'} + \alpha J \sum_{\mathbf{r}, n} \vec{\mathbf{S}}_{n, \mathbf{r}} \cdot \vec{\mathbf{S}}_{n+2, \mathbf{r}} \\
 & + \sum_{\mathbf{r}, \mathbf{c}, n} K(\mathbf{c}) \vec{\mathbf{S}}_{n, \mathbf{r}} \cdot \vec{\mathbf{S}}_{n, \mathbf{r} + \mathbf{c}}, \quad (1)
 \end{aligned}$$

where n and \mathbf{r} label lattice sites along and perpendicular to the chains and \mathbf{c} are vectors connecting neighboring chains. In order to make contact with experiments we have included next-nearest-neighbor (NNN) intrachain as well as interchain magnetic interactions.

Since J is usually much smaller than the phonon frequency, one can neglect the kinetic energy of the u field and consider u as commuting numbers. One can denote

$$\epsilon(n, \mathbf{r}) = (-1)^n (\vec{\mathbf{S}}_{n, \mathbf{r}} \cdot \vec{\mathbf{S}}_{n+1, \mathbf{r}}) \quad (2)$$

and integrate over the displacements. The result is

$$\begin{aligned}
 H_{\text{sp}} = & J \sum_{\mathbf{r}, n} \vec{\mathbf{S}}_{n, \mathbf{r}} \cdot \vec{\mathbf{S}}_{n+1, \mathbf{r}} + \frac{1}{2} \sum_{n, \mathbf{r}, \mathbf{r}'} \epsilon(n, \mathbf{r}) J(\mathbf{r} - \mathbf{r}') \epsilon(n, \mathbf{r}') \\
 & + \alpha J \sum_{\mathbf{r}, n} \vec{\mathbf{S}}_{n, \mathbf{r}} \cdot \vec{\mathbf{S}}_{n+2, \mathbf{r}} + \sum_{\mathbf{r}, \mathbf{c}, n} K(\mathbf{c}) \vec{\mathbf{S}}_{n, \mathbf{r}} \cdot \vec{\mathbf{S}}_{n, \mathbf{r} + \mathbf{c}}, \quad (3)
 \end{aligned}$$

where $J(\mathbf{r} - \mathbf{r}')$ is proportional to the matrix inverse of D . Now one can forget about phonons and use Eq. (3) as a general model for the spin-Peierls state.

In their low-temperature phases both H_{sp} and the antiferromagnet discussed below have order parameters. For the spin-Peierls model this is the staggered energy density $\langle \epsilon(n, \mathbf{r}) \rangle = \epsilon_0$ (for simplicity we assume that there is no antiferromagnetic order in the spin-Peierls model). Therefore in the low-temperature phase it is convenient to subtract from $\epsilon(n, \mathbf{r})$ its average value ($:\epsilon: \equiv \epsilon - \epsilon_0$). This leads to the Hamiltonian

$$H_{\text{sp}} = \sum_{\mathbf{r}} H_{\mathbf{r}}^{(0)} + \frac{1}{2} \sum_{n, \mathbf{r}\mathbf{r}'} : \epsilon(n, \mathbf{r}) : J(\mathbf{r} - \mathbf{r}') : \epsilon(n, \mathbf{r}') : \\ + \sum_{\mathbf{r}, \mathbf{c}, n} K(\mathbf{c}) \tilde{\mathbf{S}}_{n, \mathbf{r}} \cdot \tilde{\mathbf{S}}_{n, \mathbf{r} + \mathbf{c}}, \quad (4)$$

$$H_{\mathbf{r}}^{(0)} = J \sum_n \tilde{\mathbf{S}}_{n, \mathbf{r}} \cdot \tilde{\mathbf{S}}_{n+1, \mathbf{r}} + \alpha J \sum_n \tilde{\mathbf{S}}_{n, \mathbf{r}} \cdot \tilde{\mathbf{S}}_{n+2, \mathbf{r}} \\ + 2(J_a + J_b) \epsilon_0 \sum_n \epsilon(n, \mathbf{r}) - N \epsilon_0^2 (J_a + J_b), \quad (5)$$

where $J_{a,b}$ are the couplings (generated by the coupling to the phonons) to the neighboring chains in a and b directions (the chain direction is chosen to be c). For definiteness we assume in the following that $J_{a,b} < 0$. However, the general case can be treated by minor modifications of the formulas presented below.

Sometimes the purely one-dimensional model (5) is used to describe the low-temperature phase. We shall show below that such approximation always becomes very poor close to the spectral gap.

The second model we want to discuss consists of coupled spin- $\frac{1}{2}$ antiferromagnetic chains. Their Hamiltonian is

$$H_{\text{AFM}} = J \sum_{n, \mathbf{r}} (\tilde{\mathbf{S}}_{n, \mathbf{r}} \cdot \tilde{\mathbf{S}}_{n+1, \mathbf{r}}) + J_{\perp} \sum_{n, \mathbf{r}, \mathbf{a}} \tilde{\mathbf{S}}_{n, \mathbf{r}} \cdot \tilde{\mathbf{S}}_{n, \mathbf{r} + \mathbf{a}}, \quad (6)$$

where we take $J_{\perp} < 0$ and \mathbf{a} are lattice vectors in transverse directions. For simplicity we assume the transverse coupling to be isotropic in x and y directions. Taking the antiferromagnetic order (which we assume to be along the z direction) into account by a mean-field analysis of the interchain interaction one obtains the effective single-chain problem¹¹

$$H_0 = J \sum_n \tilde{\mathbf{S}}_n \cdot \tilde{\mathbf{S}}_{n+1} - h \sum_n (-1)^n S_n^z - 2N J_{\perp} m_0^2, \quad (7)$$

where $m_0 = \langle (-1)^n S_n^z \rangle$ and $h = -4J_{\perp} m_0$. The remaining interchain interactions will be treated in the random-phase approximation (RPA) (see Sec. VI).

II. TRANSITION TO CONTINUOUS DESCRIPTION ALONG THE CHAINS AND BOSONIZATION

We shall discuss the spin-Peierls case of weak dimerization $|\langle u \rangle| \ll 1$. In this case one can use a continuous description of the spin- $\frac{1}{2}$ Heisenberg chain which, for $\alpha < \alpha_c \approx 0.25$ (Ref. 12), is given by the Gaussian model. In the framework of this model one can express spin operators in terms of bosonic exponents (see, e.g., Ref. 13). Thus, for instance, we have

$$\epsilon(x) = \frac{\lambda}{\pi a_0} \cos(\beta \Phi) + \text{less singular terms.} \quad (8)$$

The value $\beta = \sqrt{2\pi}$ was found by Nakano and Fukuyama¹⁴ by using the Jordan-Wigner transformation with a subsequent bosonization. There is a simpler way to establish this value of β , namely, we can use the fact that the initial Hamiltonian has an SU(2) symmetry which must be respected by the bosonized form. Replacing u_n in Eq. (1) by the order

parameter, that is, treating it as a number and using Eq. (8) we obtain the sine-Gordon model. Since the SU(2) symmetry in the sine-Gordon model is not present for general values of β its requirement imposes a restriction on the value of β . The corresponding point in the sine-Gordon spectrum was discovered by Coleman¹⁵ and Haldane¹⁶ who pointed out that at $\beta = \sqrt{2\pi}$ there are only two breathers; the first one has the same mass as kink and antikink (let us call it M) and the second has the mass equal to $\sqrt{3}M$. Therefore at $\beta = \sqrt{2\pi}$ kink, antikink and the first breather realize an SU(2) triplet and the second breather becomes an SU(2) singlet.

In what follows we also need the bosonized form of the spin density in the continuum ($\tilde{\mathbf{S}}_n \rightarrow a_0 \tilde{\mathbf{S}}(x)$, $x = na_0$), which is given by

$$\tilde{\mathbf{S}}(x) = \tilde{\mathbf{J}}_R(x) + \tilde{\mathbf{J}}_L(x) + (-1)^n \vec{\mathbf{n}}(x),$$

$$J_{R,L}^z = \frac{1}{2\sqrt{2\pi}} (\partial_x \Phi \mp \Pi),$$

$$J_{R,L}^{\pm} = \frac{\mp i}{2\pi a_0} \exp[\mp i\sqrt{2\pi}(\Phi \mp \Theta)],$$

$$n^z(x) = -\frac{\lambda}{\pi a_0} \sin\sqrt{2\pi}\Phi(x),$$

$$n^{\pm}(x) = \frac{\lambda}{\pi a_0} \exp[\pm i\sqrt{2\pi}\Theta(x)]. \quad (9)$$

Here $n^a(x)$ are the components of the staggered magnetization, $J_{R,L}^{\pm,z}$ are the currents of left and right moving fermions, $na_0 = x$, and λ is a nonuniversal coefficient related to the bandgap for the charge excitations in the itinerant electron model that gives rise to the spin Hamiltonian. The field Θ is the dual of the scalar field Φ and obeys $\partial_x \Theta(x) = -\Pi(x)$, where Π is the canonical conjugate of Φ . We note that (9) differ from the ‘‘usual’’ expressions (see pp. 270–271 of Ref. 13) by a shift of the bosonic field by $\sqrt{\pi}/8$. This operation interchanges $\sin(\sqrt{2\pi}\Phi)$ and $\cos(\sqrt{2\pi}\Phi)$, but changes neither derivatives of Φ nor the dual field Θ .

Notice that despite the fact that $\epsilon(x)$ has the same dimension as the z component of the staggered magnetization, it is given by a different operator (sine instead of cosine). In fact $\epsilon(x)$ is the $2k_F$ component of the charge density in the system with a frozen charge field. As we shall see the situation is somewhat similar to that for the spin-ladder (see, for example, Ref. 17), but there are also certain subtle differences. Substituting Eq. (8) into Eqs. (4) we get the following bosonized version of the spin-Peierls Hamiltonian $H_{\text{sp}} = \sum_{\mathbf{r}} H_{\mathbf{r}}^{(0)} + V_{\text{phonon}} + V_{\text{spin}}$:

$$H_{\mathbf{r}}^{(0)} = \frac{v}{2} \int dx [\Pi_{\mathbf{r}}^2 + (\partial_x \Phi_{\mathbf{r}})^2] + \mu \int dx \cos(\sqrt{2\pi}\Phi_{\mathbf{r}}) \\ - N \epsilon_0^2 (J_a + J_b), \quad (10)$$

$$V_{\text{phonon}} = \frac{\lambda^2}{2\pi^2 a_0^2} \sum_{\mathbf{r}, \mathbf{r}'} \int dx : \cos[\sqrt{2\pi}\Phi_{\mathbf{r}}(x)] : \\ \times J(\mathbf{r} - \mathbf{r}') : \cos[\sqrt{2\pi}\Phi'_{\mathbf{r}}(x)] :, \quad (11)$$

$$V_{\text{spin}} = \frac{\lambda^2}{\pi^2 a_0^2} \sum_{\mathbf{r}, \mathbf{c}} \int dx K(\mathbf{c}) \vec{n}_{\mathbf{r}}(x) \cdot \vec{n}_{\mathbf{r}+\mathbf{c}}(x), \quad (12)$$

where $\mu = (2\epsilon_0 \lambda / \pi a_0) (J_a + J_b)$. Note that we have kept only the most relevant terms and neglected, e.g., the Umklapp term (for a discussion of the role of the Umklapp term see Ref. 14). Our strategy is now to use exact results for the sine-Gordon Hamiltonian (10) describing a single chain (see also Refs. 18, 19) and to treat the residual interchain interaction V in the random-phase approximation (RPA).

The Hamiltonian (10) describing a single chain is of the form $vH_0 - N\epsilon_0^2(J_a + J_b)$. The spectrum of H_0 is well-known:²⁰ it is described in terms of a soliton, an antisoliton, a bound state (called ‘‘breather’’) of mass M and a second breather of mass $\sqrt{3}M$. The mass gap M of the model is due to the dimerization caused by the coupling to the phonons. It is related to the scale μ as²¹

$$\mu = \frac{\Gamma(1/4)}{\pi\Gamma(3/4)} \left[M \sqrt{\frac{\pi\Gamma(2/3)}{4\Gamma(1/6)}} \right]^{3/2}. \quad (13)$$

The ground state energy density of H_0 is then given by $e = -(M^2/4)\tan(\pi/6)$, which in turn yields an expression for the ground state energy density of H as a function of ϵ_0 . Minimization with respect to ϵ_0 yields the following mean field expressions for ϵ_0 and mass gap \mathcal{M} of $H_{\mathbf{r}}^{(0)}$ as functions of the dimensionless (nonuniversal) parameter λ^2/a_0 and the couplings $J_{a,b}$ and J :

$$\begin{aligned} \epsilon_0 &= \sqrt{\frac{2}{\pi}} \left(\frac{\tan(\pi/6)}{12} \right)^{3/2} \left(\frac{2\Gamma(1/6)}{\sqrt{\pi}\Gamma(2/3)} \right)^3 \\ &\quad \times \left(\frac{2\Gamma(3/4)}{\Gamma(1/4)} \right)^2 \frac{\lambda^2}{a_0} \left(\frac{|J_a + J_b|}{2J\kappa} \right)^{1/2} \\ &=: \mathcal{C} \left(\frac{|J_a + J_b|}{2J\kappa} \right)^{1/2}, \\ \mathcal{M} = vM &= \frac{\tan(\pi/6)}{12} \left(\frac{2\Gamma(1/6)}{\sqrt{\pi}\Gamma(2/3)} \right)^3 \left(\frac{2\Gamma(3/4)}{\Gamma(1/4)} \right)^2 \\ &\quad \times \frac{\lambda^2}{a_0} \frac{|J_a + J_b|}{2} =: \mathcal{C}' \frac{|J_a + J_b|}{2}. \end{aligned} \quad (14)$$

Here we have used $v = (\pi/2)Ja_0\kappa$ for the Fermi velocity, where κ is a function of the NNN coupling α . The ratio of the constants \mathcal{C} and \mathcal{C}' is found to be

$$\frac{\mathcal{C}}{\mathcal{C}'} = \frac{1}{3^{3/4}\sqrt{2\pi}} \approx 0.175013. \quad (15)$$

Equation (14) makes it clear that the gap originates from the interchain interactions.

III. SINE-GORDON CORRELATION FUNCTIONS AT $\beta^2 = 2\pi$

In this section we derive exact results for various correlation functions of the sine-Gordon model (10) for $\beta = \sqrt{2\pi}$. We start by constructing a convenient basis of states for the sine-Gordon theory by means of the Zamolodchikov-

Faddeev algebra. This is based on the knowledge of the exact spectrum and scattering matrix of the model.^{22,23} We then formulate the problem of calculating correlation functions in terms of *formfactors* and finally give explicit results for the first few terms in the formfactor expansion.

The Zamolodchikov-Faddeev (ZF) algebra for the sine-Gordon model with $\beta^2 = 2\pi$ was derived by Affleck²⁴ who suggested a representation which manifestly respects the SU(2) symmetry. As mentioned above there are three single particle states with mass M which form a triplet under the SU(2) symmetry. The corresponding creation and annihilation operators are denoted by $Z_a^+(\theta), Z_a(\theta)$ ($a = \pm\frac{1}{2}, 1$). Here 1 denotes the breather state and $\pm\frac{1}{2}$ denote soliton and antisoliton states, respectively. In addition there is one single-particle breather state with mass $\sqrt{3}M$, which transforms as a singlet under SU(2). Its creation and annihilation operators are denoted by $Z_2^+(\theta), Z_2(\theta)$. As usual the eigenstates are parametrized by a rapidity variable θ such that their momentum and energy are equal to

$$p_j = M_j \sinh \theta_j, \quad \epsilon_j = M_j \cosh \theta_j, \quad (16)$$

where $M_j = \sqrt{3}M$ for the singlet state and $M_j = M$ for the triplet states. By definition the ZF operators (and their Hermitian conjugates) satisfy the algebra

$$Z_a(\theta_1)Z_b(\theta_2) = S_{a,b}(\theta_1 - \theta_2)Z_b(\theta_2)Z_a(\theta_1), \quad a, b = \pm\frac{1}{2}, 1,$$

$$Z_a(\theta_1)Z_2(\theta_2) = S_{a,2}(\theta_1 - \theta_2)Z_2(\theta_2)Z_a(\theta_1), \quad a = \pm\frac{1}{2}, 1,$$

$$Z_2(\theta_1)Z_2(\theta_2) = S_{2,2}(\theta_1 - \theta_2)B(\theta_2)B(\theta_1), \quad (17)$$

where the two-particle scattering matrices $S_{ij}(\theta)$ are given by

$$S_{a,b}(\theta) = \frac{\sinh \theta + i \sin(\pi/3)}{\sinh \theta - i \sin(\pi/3)} =: S_0(\theta), \quad a, b = \pm\frac{1}{2}, 1,$$

$$S_{a,2}(\theta) = S_0\left(\theta + i\frac{\pi}{6}\right)S_0\left(\theta - i\frac{\pi}{6}\right), \quad a = \pm\frac{1}{2}, 1,$$

$$S_{2,2}(\theta) = \left(\frac{\sinh \theta + i \sin(\pi/3)}{\sinh \theta - i \sin(\pi/3)} \right)^3. \quad (18)$$

For the creation and annihilation operators we have

$$\begin{aligned} Z_a(\theta_1)Z_b^+(\theta_2) &= S_0(\theta_2 - \theta_1)Z_b^+(\theta_2)Z_a(\theta_1) \\ &\quad + 2\pi\delta_{ab}\delta(\theta_1 - \theta_2), \quad a, b = \pm\frac{1}{2}, 1, \end{aligned}$$

$$Z_a(\theta_1)Z_2^+(\theta_2) = S_{a,2}(\theta_2 - \theta_1)Z_2^+(\theta_2)Z_a(\theta_1),$$

$$\begin{aligned} Z_2(\theta_1)Z_2^+(\theta_2) &= S_{2,2}(\theta_2 - \theta_1)Z_2^+(\theta_2)Z_2(\theta_1) \\ &\quad + 2\pi\delta(\theta_1 - \theta_2). \end{aligned} \quad (19)$$

From Eq. (18) it follows that $S_{i,i}(0) = -1$ and $S_{i,i}(\infty) = +1$. Therefore particles with close momenta be-

have as free fermions and particles far apart in momentum space behave like free bosons.

We note that the soliton S matrix $S_0(\theta)$ has simple poles at $\theta=i(\pi/3)$ and $\theta=i(2\pi/3)$. These poles correspond to the two breather bound states. In other words a soliton and an antisoliton can form a bound state of either mass M or mass $\sqrt{3}M$. Although the S matrix of light breathers is the same only the pole $\theta=i(\pi/3)$ corresponds to a bound state—the heavy breather. The pole at $\theta=i(2\pi/3)$ is *redundant*.²⁵ The soliton-breather S matrices $S_{a,1}(\theta)$ and $S_{a,2}(\theta)$ exhibit soliton poles at $\theta=i(\pi/2)\pm i(\pi/6)$ and $\theta=i(\pi/2)\pm i(\pi/3)$, respectively. All other poles are redundant and do not indicate the presence of bound states. From the analytic properties of the S matrices (18) we deduce relations between the ZF operators. For example we find

$$Z_2\left(\frac{\theta_1+\theta_2}{2}\right)=\lim_{\theta_1-\theta_2\rightarrow i\pi/3}Z_1(\theta_2)Z_1(\theta_1). \quad (20)$$

Such relations between the ZF operators play an important role in what follows.

States in the Fock space are constructed by acting with the operators $Z_\varepsilon^\dagger(\theta)$ on the vacuum state $|0\rangle$

$$|\theta_n\cdots\theta_1\rangle_{\varepsilon_n\cdots\varepsilon_1}=Z_{\varepsilon_n}^\dagger(\theta_n)\cdots Z_{\varepsilon_1}^\dagger(\theta_1)|0\rangle, \quad (21)$$

where $\varepsilon_j=\pm\frac{1}{2},1,2$. We note that Eq. (17) together with Eq. (21) implies that states with different ordering of two rapidities *and* indices ε_i are related by multiplication with two-particle S matrices

$$\begin{aligned} &|\theta_n\cdots\theta_k\theta_{k+1}\cdots\theta_1\rangle_{\varepsilon_n\cdots\varepsilon_k\varepsilon_{k+1}\cdots\varepsilon_1} \\ &=S_{\varepsilon_k,\varepsilon_{k+1}}(\theta_k-\theta_{k+1}) \\ &\quad\times|\theta_n\cdots\theta_{k+1}\theta_k\cdots\theta_1\rangle_{\varepsilon_n\cdots\varepsilon_{k+1}\varepsilon_k\cdots\varepsilon_1}. \end{aligned} \quad (22)$$

The resolution of the identity is given by

$$1=\sum_{n=0}^{\infty}\sum_{\varepsilon_i}\int\frac{d\theta_1\cdots d\theta_n}{(2\pi)^n n!}|\theta_n\cdots\theta_1\rangle_{\varepsilon_n\cdots\varepsilon_1}\langle\theta_1\cdots\theta_n|_{\varepsilon_1\cdots\varepsilon_n}. \quad (23)$$

The form-factor approach is based on the idea of inserting Eq. (23) between the operators in a correlation function

$$\begin{aligned} &\langle\mathcal{O}(x,t)\mathcal{O}^\dagger(0,0)\rangle \\ &=\sum_{n=0}^{\infty}\sum_{\varepsilon_i}\int\frac{d\theta_1\cdots d\theta_n}{(2\pi)^n n!}\exp\left(i\sum_{j=1}^n p_j x-\varepsilon_j t\right) \\ &\quad\times|\langle 0|\mathcal{O}(0,0)|\theta_n\cdots\theta_1\rangle_{\varepsilon_n\cdots\varepsilon_1}|^2, \end{aligned} \quad (24)$$

and then determining the form factors

$$F^{\mathcal{O}}(\theta_1\cdots\theta_n)_{\varepsilon_1\cdots\varepsilon_n}:=\langle 0|\mathcal{O}(0,0)|\theta_n\cdots\theta_1\rangle_{\varepsilon_n\cdots\varepsilon_1} \quad (25)$$

by taking advantage of their known analytic properties.

From a physical point of view we are interested in the Fourier transforms of the connected retarded two-point cor-

relators of $(-1)^R\cos\sqrt{2\pi}\Phi(x)$ and $(-1)^R\sin\sqrt{2\pi}\Phi(x)$. Their form-factor expansions are of the form

$$\begin{aligned} D^{\cos}(\omega,q)&=\int_{-\infty}^{\infty}dx\int_0^{\infty}dt e^{i(\omega+i\varepsilon)t-i(vq/a_0)x} \\ &\quad\times\langle[\cos\sqrt{2\pi}\Phi(t,x),\cos\sqrt{2\pi}\Phi(0,0)]\rangle \\ &=-2\pi\sum_{n=0}^{\infty}\sum_{\varepsilon_i}\int\frac{d\theta_1\cdots d\theta_n}{(2\pi)^n n!} \\ &\quad\times|F^{\cos}(\theta_1\cdots\theta_n)_{\varepsilon_1\cdots\varepsilon_n}|^2 \\ &\quad\times\left\{\frac{\delta\left(vq/a_0-\sum_j M_j\sinh\theta_j\right)}{\omega-\sum_j M_j\cosh\theta_j+i\varepsilon}\right. \\ &\quad\left.-\frac{\delta\left(vq/a_0+\sum_j M_j\sinh\theta_j\right)}{\omega+\sum_j M_j\cosh\theta_j+i\varepsilon}\right\}. \end{aligned} \quad (26)$$

Here we have reinserted the Fermi velocity v and lattice spacing a_0 . The Fourier transform $D^{\sin}(\omega,q)$ of the connected retarded two-point correlator of $\sin\sqrt{2\pi}\Phi$ is the dynamical staggered susceptibility and will also be denoted by $\chi''(\omega,q)$.

In order to implement the form-factor expansion it is very useful to note that (as for general values of β) operators from different representations behave differently under the charge conjugation transformation

$$C\Phi C^{-1}=-\Phi,$$

$$CZ_{\pm 1/2}(\theta)C^{-1}=\mathcal{Z}_{\pm 1/2}(\theta), \quad CZ_1(\theta)C^{-1}=-Z_1(\theta),$$

$$CZ_2(\theta)C^{-1}=Z_2(\theta). \quad (27)$$

These transformation properties imply the expansion

$$\begin{aligned} &\sin[\sqrt{2\pi}\Phi(t,x)]|0\rangle \\ &=F_1\int\frac{d\theta}{2\pi}e^{-iM(t\cosh\theta-x\sinh\theta)}Z_1^\dagger(\theta)|0\rangle \\ &\quad+\int\frac{d\theta_1}{2\pi}\frac{d\theta_2}{2\pi}e^{-iM[t(\cosh\theta_1+\cosh\theta_2)-x(\sinh\theta_1+\sinh\theta_2)]} \\ &\quad\times U(\theta_1,\theta_2)[Z_{1/2}^+(\theta_1)Z_{-1/2}^+(\theta_2) \\ &\quad-Z_{-1/2}^+(\theta_1)Z_{1/2}^+(\theta_2)]+\cdots, \end{aligned} \quad (28)$$

where $U(\theta_1, \theta_2) = U(\theta_2, \theta_1)$. Significantly, due to the SU(2) symmetry transverse components of the staggered magnetization have the same correlation functions as n_{stag}^z [this is clear from the SU(2) symmetry of the Hamiltonian (5)]. Consequently we conclude that Sine-Gordon two-point correlation functions (for $\beta = \sqrt{2\pi}$) of $\sin\sqrt{2\pi}\theta$ and $\cos\sqrt{2\pi}\theta$ are the same as two-point correlators of $\sin\sqrt{2\pi}\Phi$.

The current operator $\partial_x\Phi$ is also odd in Φ and therefore its expansion must begin with \mathcal{Z}_0 such that at small q we have

$$\langle\langle\tilde{\mathbf{S}}(\omega, q)\tilde{\mathbf{S}}(-\omega, -q)\rangle\rangle \sim \frac{(v^2/a_0^2)q^2}{\omega^2 - (v^2/a_0^2)q^2 - M^2} + \dots, \quad (29)$$

where the ellipsis denotes terms which have nonzero imaginary parts at higher energies.

As we will see the threshold of the dynamical spin susceptibility is equal to M for both $q=0$ and $q=\pi$. This is a distinct feature of the alternating chain. It is related to the fact that kink and antikink create a bound state of the same mass. Recall that for the ladder chain (or $S=1$ antiferromagnet for this matter) where particles do not have bound states, the value of the energy threshold at $q=0$ is twice that at $q=\pi$ (see Ref. 17).

At frequencies smaller than $(1+\sqrt{3})M$ the only contributions to the imaginary part of the magnetic susceptibility come from the first breather and kink-antikink pairs. Kink-antikink form factors can be calculated in the Sine-Gordon model (for any value of the coupling β) along the following lines.^{26,27} Let us denote by $S_+(\theta)$ [$S_-(\theta)$] the S -matrix ei-

genvalue corresponding to positive (negative) C parity obtained by diagonalizing the kink-antikink scattering:

$$\begin{aligned} S_+ &= \frac{\sinh(\pi/2\xi)(\theta+i\pi)}{\sinh(\pi/2\xi)(\theta-i\pi)} S_0(\theta), \\ S_- &= \frac{\cosh(\pi/2\xi)(\theta+i\pi)}{\cosh(\pi/2\xi)(\theta-i\pi)} S_0(\theta), \end{aligned} \quad (30)$$

where $\xi = \pi\beta^2/(8\pi - \beta^2)$ and

$$S_0(\theta) = -\exp\left(-i \int_0^\infty \frac{dx}{x} \frac{\sin\theta x \sinh[(\pi-\xi)/2]x}{\cosh(\pi x/2) \sinh(\xi x/2)}\right). \quad (31)$$

Then, general unitarity and crossing arguments imply that the corresponding kink-antikink form factors $F_\pm(\theta)$ are solutions of the system of functional equations

$$F_\pm(-\theta) = S_\pm(\theta)F_\pm(\theta), \quad (32)$$

$$F_\pm(\theta - 2i\pi) = \pm F_\pm(-\theta). \quad (33)$$

The ‘‘minimal’’ solutions of these equations are

$$\begin{aligned} F_+(\theta) &= \frac{\sinh\theta}{\sinh(\theta+i\pi)(\pi/2\xi)} F_0(\theta) \\ F_-(\theta) &= \frac{\sinh\theta}{\cosh(\theta+i\pi)(\pi/2\xi)} F_0(\theta), \end{aligned} \quad (34)$$

where F_0 is given by

$$F_0(\theta) = \sinh\frac{\theta}{2} \exp\left(\int_0^\infty \frac{dx}{x} \frac{\sinh(x/2)(1-\xi/\pi)\sin^2[x(i\pi+\theta)/2\pi]}{\sinh(x\xi/2\pi)\cosh(x/2)\sinh x}\right). \quad (35)$$

By minimal solution we mean a solution containing only the expected bound state poles in the physical strip and with the mildest asymptotic behavior at infinity. This prescription determines the minimal solution *uniquely*. An infinite number of nonminimal solutions corresponding to all operators in the theory which are local with respect to the solitons are obtained multiplying the minimal solution by an analytic function of $\cosh\theta$. However, if we require the form factor to be power bounded in the momenta and to have only the bound state poles, we conclude that we can actually multiply the minimal solution only by a polynomial in $\cosh\theta$. For a given operator, it is possible to put strong constraints on the asymptotic behavior of its form factors, and then on the degree of the allowed polynomial.²⁸ In the sine-Gordon model this procedure is complicated by a nontrivial behavior of correlators in the ultraviolet limit. Nevertheless, the result is that for the operators \cos and \sin the allowed polynomial is of the zero degree, which means that their form factors coincide with the minimal ones. The same conclusion can be reached in a simpler way going to the free fermion point

$\xi = \pi$, where the form factors of \sin and \cos can be easily computed remembering that

$$\cos\beta\Phi \sim \bar{\Psi}\Psi, \quad \varepsilon_{\mu\nu}\partial^\nu\Phi \sim J_\mu, \quad (36)$$

and that the \sin is related to the elementary field by the equation of motion.

For the operators $\cos\beta\Phi$ and $\sin\beta\Phi$, at the specific value of the coupling we are interested in, we find ($\theta_{12} = \theta_1 - \theta_2$)

$$\begin{aligned} \langle 0 | \sin\sqrt{2\pi}\Phi | \theta_1, \theta_2 \rangle_{-+} &= \sqrt{3}(2d)Z^{1/2} \frac{\cosh\theta_{12}/2}{\sinh 3\theta_{12}/2} \zeta(\theta_{12}) \\ &= F^{\sin}(\theta)_{-+}, \end{aligned} \quad (37)$$

$$\begin{aligned} \langle 0 | \cos\sqrt{2\pi}\Phi | \theta_1, \theta_2 \rangle_{-+} &= i\sqrt{3}(2d)Z^{1/2} \frac{\cosh\theta_{12}/2}{\cosh 3\theta_{12}/2} \zeta(\theta_{12}) \\ &= F^{\cos}(\theta_{12})_{-+}, \end{aligned} \quad (38)$$

$$\zeta(\theta) = c \sinh \theta/2 \exp \left\{ 2 \int_0^\infty dx \frac{\sin^2[x(\theta + i\pi)/2] \cosh \pi x/6}{x \sinh \pi x \cosh \pi x/2} \right\},$$

$$c = (12)^{1/4} \exp \left\{ \frac{1}{2} \int_0^\infty dx \frac{\sinh x/2 \cosh x/6}{x \cosh^2 x/2} \right\} \approx 3.494607,$$

$$d = \frac{3}{2\pi c} \approx 0.136629, \quad (39)$$

where the relative normalization between the two operators can be fixed exploiting the asymptotic factorization of form factors discussed in Ref. 29. We note that $\zeta(\theta)$ is to be analytically continued using the relation

$$\zeta(\theta) S_0(\theta) = \zeta(-\theta). \quad (40)$$

The additional factors d and c in Eqs. (37) and (38) have been introduced in order to simplify the reduction of multiparticle form factors using the annihilation-pole condition (for soliton form factors)

$$\begin{aligned} i \text{Res} F^{\mathcal{O}}(\theta_1 \cdots \theta_{2n})_{\varepsilon_1 \cdots \varepsilon_{2n}} \Big|_{\theta_{2n} - \theta_{2n-1} = i\pi} \\ = F^{\mathcal{O}}(\theta_1 \cdots \theta_{2n-2})_{\varepsilon'_1 \cdots \varepsilon'_{2n-2}} \delta_{\varepsilon_{2n}}^{-\varepsilon'_{2n-1}} \{ \delta_{\varepsilon_1}^{\varepsilon'_1} \cdots \delta_{\varepsilon_{2n-1}}^{\varepsilon'_{2n-1}} \\ - S_{\tau_1, \varepsilon_1}^{\varepsilon'_{2n-1}, \varepsilon'_1}(\theta_{2n-1} - \theta_1) \cdots S_{\varepsilon_{2n-1}, \varepsilon_{2n-2}}^{\tau_{2n-3}, \varepsilon'_{2n-2}} \\ \times (\theta_{2n-1} - \theta_{2n-2}) \}, \end{aligned} \quad (41)$$

where $S_{\varepsilon, \varepsilon}^{\varepsilon, \varepsilon}(\theta) = S_{\varepsilon, \varepsilon}^{\varepsilon', \varepsilon'}(\theta) = S_{1,1}(\theta)$ and all other components are zero. Multiparticle form factors are discussed in some detail in Appendix A.

The form factor (37) has a pole at $\theta_{12} = -2i\pi/3$ corresponding to formation of a bound state—the first breather. The breather form factor F_1 is given by the residue of Eq. (37) divided by the three-particle coupling

$$\begin{aligned} |F_1|^2 &= \frac{3^{3/2}}{8\pi^2} \exp \left(-2 \int_0^\infty \frac{dx \sinh \pi x/6 \sinh \pi x/3}{x \sinh \pi x \cosh \pi x/2} \right) Z \\ &\approx 0.0533Z. \end{aligned} \quad (42)$$

Similarly Eq. (38) has a pole at $\theta_{12} = -i\pi/3$ corresponding to the second breather. The absolute square $|F_2|^2$ of the breather form factor is found to be

$$\begin{aligned} |F_2|^2 &= \frac{3^{3/2}}{8\pi^2} \exp \left(-4 \int_0^\infty \frac{dx \cosh \pi x/6 \sinh^2 \pi x/3}{x \sinh \pi x \cosh \pi x/2} \right) Z \\ &\approx 0.0262Z. \end{aligned} \quad (43)$$

IV. DYNAMICAL SUSCEPTIBILITIES FOR A SINGLE ALTERNATING CHAIN

The expression for the imaginary part of the dynamical staggered susceptibility $\chi''(\omega, q)$ at $s^2 = \omega^2 - (v^2/a_0^2) \times (\pi - q)^2 < (1 + \sqrt{3})^2 M^2$ is given by

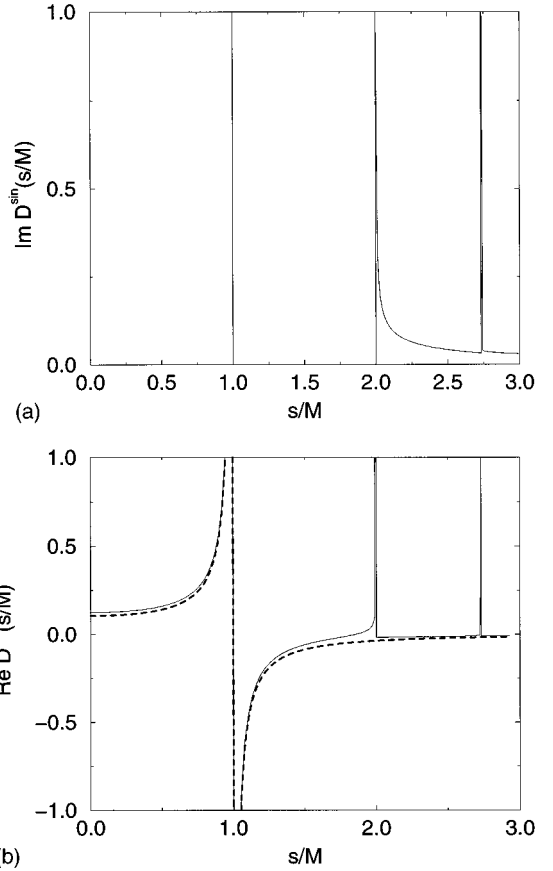

FIG. 1. Imaginary and real parts (in units of Z/M^2) of the dynamical staggered susceptibility as functions of $s = \sqrt{\omega^2 - (v^2/a_0^2)(\pi - q)^2}$ for $q \approx \pi$. The dashed line depicts the single-mode approximation that takes into account only the first breather.

$$\text{Im} \chi''(\omega, q) = 2\pi |F_1|^2 \delta(s^2 - M^2) + 2 \text{Re} \frac{|F^{\sin}[\theta(s)]_{+-}|^2}{s \sqrt{s^2 - 4M^2}}, \quad (44)$$

where $\theta(s) = 2 \ln(s/2M + \sqrt{s^2/4M^2 - 1})$. Note that all other form factors do not contribute to this expression in the specified range of s as their thresholds are above $(1 + \sqrt{3})M$. Also the normalization Z enters Eq. (44) only as an overall factor. Since the function $\zeta(\theta)$ vanishes at $\theta=0$, the entire form factor is also finite. Thus the two-particle contribution to $\chi''(\omega, q)$ exhibits a square-root singularity at the threshold as a function of s .

The breather and $s\bar{s}$ contributions to the real part are found to be

$$\begin{aligned} \text{Re} \chi''(\omega, q) &= -\text{Re} \frac{2|F_1|^2}{s^2 - M^2 + i\varepsilon} \\ &\quad - 2 \int_0^\infty \frac{d\theta}{\pi} \frac{s^2 - 4M^2 \cosh^2(\theta/2)}{[s^2 - 4M^2 \cosh^2(\theta/2)]^2 + \varepsilon^2} |F^{\sin}(\theta)_{+-}|^2, \end{aligned} \quad (45)$$

where the factor of 2 stems from the sum over $+$ and $-$. In Fig. 1 we plot both the imaginary and real parts of χ'' .

It is straightforward to repeat the above analysis for the current operator $\partial_x \Phi$ using the explicit expressions for the formfactors given in Ref. 27. The contribution of the first breather leads to to Eq. (29) with some normalization factor. As there is very little spectral weight at $q \approx 0$ we concentrate on $q \approx \pi$ and do not repeat the above analysis for the current operator.

For practical purposes it is convenient to have an expression interpolating between the small q (29) and $q \approx \pi$ (44) behavior. Such an expression giving the dynamical spin susceptibility in the entire range of q at frequencies below the continuum may look as

$$\chi(\omega, q) = \frac{g(q) \sin^2(q/2)}{\omega^2 - (v^2/a_0^2) \sin^2 q - M^2} + \dots, \quad (46)$$

where $g(q)$ is a smooth function interpolating between the normalizations at $q=0$ and $q=\pi$. The mode $\omega = \sqrt{(v^2/a_0^2) \sin^2 q + M^2}$ is separated from the particle continuum by the gap of order of M .

Let us now turn to the two-point correlator of cosines. The contributions of the second breather and the soliton-antisoliton continuum are given by

$$\begin{aligned} \text{Im} D^{\text{cos}}(\omega, q) &= 2\pi |F_2|^2 \delta(s^2 - 3M^2) \\ &+ 2 \text{Re} \frac{|F^{\text{cos}}[\theta(s)]_{+-}|^2}{s \sqrt{s^2 - 4M^2}}, \end{aligned} \quad (47)$$

where the ratio of the single particle residues is universal:

$$\gamma = \frac{|F_2|^2}{|F_1|^2} = \exp\left(-\int_0^\infty dx \frac{\sinh x/3}{x \cosh^2(x/2)}\right) \approx 0.49131. \quad (48)$$

Note that the threshold of the breather-breather continuum is also at $s=2M$. The corresponding contribution is taken into account in Appendix A (see Fig. 2). The analogous contributions to the real part of D^{cos} are given by

$$\begin{aligned} \text{Re} D^{\text{cos}}(\omega, q) &= -\text{Re} \frac{2|F_2|^2}{s^2 - 3M^2 + i\epsilon} \\ &- 2 \int_0^\infty \frac{d\theta}{\pi} \frac{s^2 - 4M^2 \cosh^2 \theta/2}{(s^2 - 4M^2 \cosh^2(\theta/2))^2 + \epsilon^2} |F^{\text{cos}}(\theta)_{+-}|^2. \end{aligned} \quad (49)$$

The remaining integrals in Eqs. (44), (45), (47), and (49) have to be calculated numerically. We find that at small s the contributions of the two-particle continua to the real parts of both correlators are of the same magnitude as the single-particle contributions from the breather states. As far as a single chain is concerned a single-mode approximation taking into account only the one-particle states is therefore very poor at small s .

V. RPA ANALYSIS OF THE INTERCHAIN INTERACTIONS

Let us now take into account the interchain interactions (both of spin and staggered energy densities) in Eq. (4). This

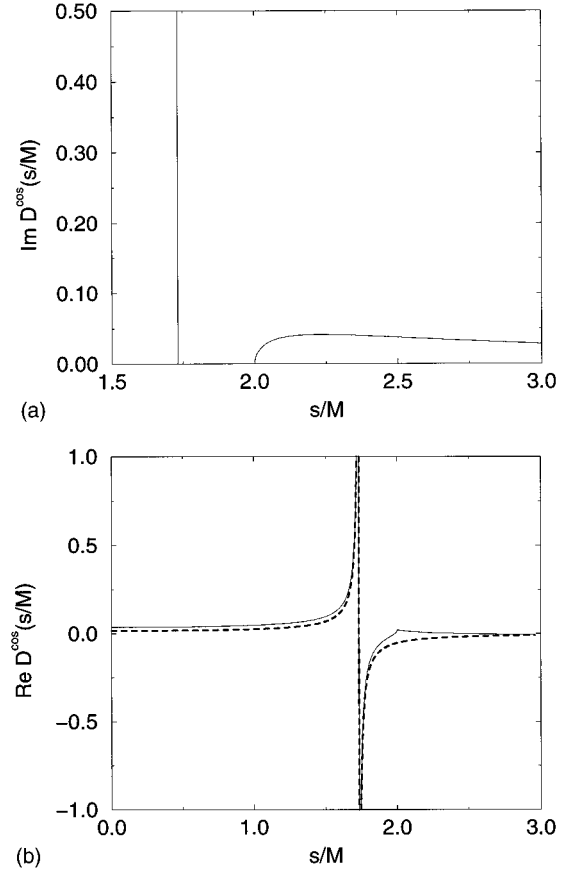

FIG. 2. Imaginary and real parts of D^{cos} (in units of Z/M^2) as functions of $s = \sqrt{\omega^2 - (v^2/a_0^2)(\pi - q)^2}$ for $q \approx \pi$.

is accomplished through an RPA analysis along the lines of Ref. 30. RPA becomes exact in the limit of an infinite number of neighboring chains.

In the RPA we obtain the following expression for the correlation function of energy densities:

$$\chi_\epsilon(s, \vec{k}) = \langle\langle \epsilon(-\omega, -q; -\vec{k}) \epsilon(\omega, q; \vec{k}) \rangle\rangle = \frac{D^{\text{cos}}(s)}{1 - D^{\text{cos}}(s) J(\vec{k})}, \quad (50)$$

where $J(\vec{k}) = 2[|J_a| \cos(k_x) + |J_b| \cos(k_y)]$. Similarly the dynamical staggered susceptibility is given by

$$\begin{aligned} \chi^{zz}(s, \vec{k}) &= \langle\langle S^z(-\omega, -q; -\vec{k}) S^z(\omega, q; \vec{k}) \rangle\rangle \\ &= \frac{D^{\text{sin}}(s)}{1 + D^{\text{sin}}(s) K(\vec{k})}, \end{aligned} \quad (51)$$

where $K(\vec{k}) = 2[K_a \cos(k_x) + K_b \cos(k_y)]$. Note that in the present approximation $\chi_\epsilon(s, \vec{k})$ is only affected by the interchain interactions of staggered energy densities, whereas $\chi^{zz}(s, \vec{k})$ only ‘‘sees’’ the interchain interactions of spin densities. The reason for this decoupling is that in the sine-Gordon theory describing the individual chains

$$\langle\epsilon(t, x) S^z(0, 0)\rangle = 0, \quad (52)$$

because $\varepsilon(t, x)$ is even under charge conjugation whereas $S^z(0, 0)$ is odd. By rotational invariance this implies $\langle \varepsilon(t, x) \vec{S}(0, 0) \rangle = 0$. Note that the RPA is particularly simple as we have taken into account only interchain interactions of the staggered part of the spin density and neglected the smooth part as being less relevant. If we take these subleading terms into account the RPA acquires a matrix structure as in Ref. 11 as the sectors $q \approx \pi$ and $q \approx 0$ become coupled. An RPA analysis then requires the calculation of form factors of the current operator. We will discuss this refined RPA in a separate publication.³¹

The response functions $\chi^{\alpha\alpha}(s, \vec{k})$ and $\chi_\varepsilon(s, \vec{k})$ can be easily calculated numerically for given values of $J_{a,b}$ and $K_{a,b}$ by using the expressions for $D^{\sin}(s)$ and $D^{\cos}(s)$ obtained in Sec. IV. We note that the pole in the dynamical magnetic susceptibilities $\chi^{\alpha\alpha}(s, \vec{k})$ corresponds to the light breather which has quantum number $S^z = 1$, whereas the pole in $\chi_\varepsilon(s, \vec{k})$ is due to the heavy breather with $S^z = 0$. The magnetic mode can be measured directly by neutron scattering, whereas the $S^z = 0$ excitation can be probed by measuring the phonon spectrum which will exhibit a softening.

In order to visualize our results we now plot them for a particular choice of parameters. Being aware that our theory probably cannot be applied to CuGeO_3 where $\alpha > \alpha_c$ we nevertheless choose these parameters to reproduce the dispersions of magnetic excitations in that material. We take $\kappa \approx 0.8$, $M \approx 4.58$ MeV and $|K_b|Z/M^2 \approx 3.08$, $|K_a|Z/M^2 \approx 0.25$. The value of κ is chosen such that the dispersion in z -direction reproduces the experimental fit of Ref. 4, whereas the other conditions follow from the experimental band gaps for \vec{k} vectors $(0, 1, \frac{1}{2})$ (≈ 2 MeV), $(0, 0, \frac{1}{2})$ (≈ 5.7 MeV), and $(\frac{1}{2}, 1, \frac{1}{2})$ (≈ 2.6 MeV).

Because of Lorentz invariance the energy ω and the z component of the momentum q only enter in the combination $s = \sqrt{\omega^2 - (v^2/a_0^2)(\pi - q)^2}$. In Fig. 3(a) we plot the spin-wave dispersion in the x direction [$k_y = 0$, $k_x \in (0, \pi)$] and in Fig. 3(b) in the y direction [$k_x = 0$, $k_y \in (0, \pi)$].

We see that the single-mode approximation (SMA) in which all multiparticle contributions to the dynamical susceptibilities are neglected gives essentially the same result as the exact treatment. We note that (by construction) the fits⁴ to the experimental results are essentially identical to the SMA as far as dispersion relations are concerned. Let us now turn to the multiparticle continuum. The imaginary part of the dynamical staggered susceptibility is directly measurable by Neutron scattering. The position of its poles yields the dispersion discussed above. The incoherent part (as a function of s and $k_{x,y}$) is plotted in Fig. 4(a) and 4(b), respectively.

In the RPA the two-particle continuum starts at $s = 2M \approx 9$ MeV. This is in disagreement with experiment for CuGeO_3 .

VI. ANTIFERROMAGNETIC ORDER

In the continuum limit the model (7) is also equivalent to the sine-Gordon model with $\beta^2 = 2\pi$.¹¹ The bosonization formulas are now

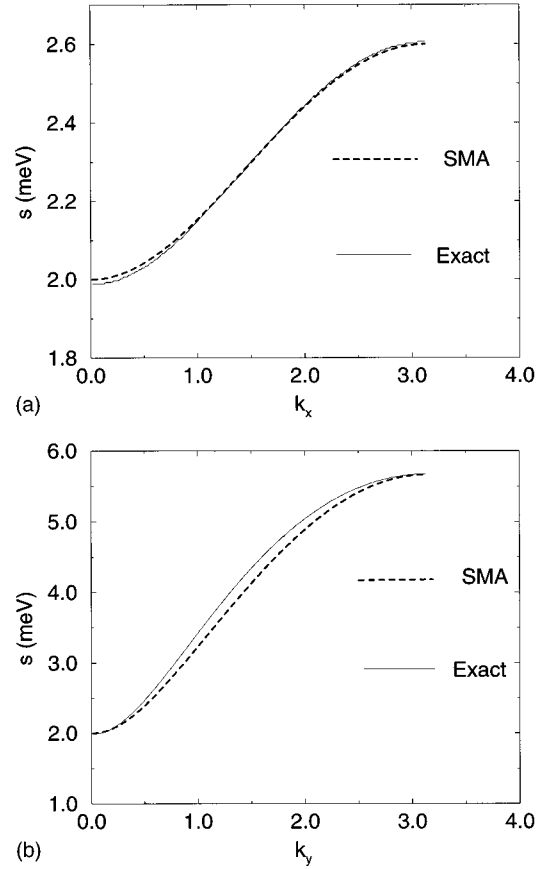

FIG. 3. Spin-wave dispersions in x (a) and y (b) directions.

$$\vec{S}(x) = \vec{J}_R(x) + \vec{J}_L(x) + (-1)^n \vec{n}(x),$$

$$J_{R,L}^z = \frac{1}{2\sqrt{2}\pi} (\partial_x \Phi \mp \Pi),$$

$$J_{R,L}^+ = \frac{1}{2\pi a_0} \exp[\mp i\sqrt{2}\pi(\Phi \mp \Theta)],$$

$$n^z(x) = -\frac{\lambda}{\pi a_0} \cos\sqrt{2}\pi\Phi(x),$$

$$n^\pm(x) = \frac{\lambda}{\pi a_0} \exp[\pm i\sqrt{2}\pi\Theta(x)]. \quad (53)$$

Since the staggered magnetization is proportional to $\sin(\sqrt{2}\pi\Phi)$ the bosonized single-chain Hamiltonian is given by

$$H = \frac{v}{2} \int dx \{ \pi^2(x) + [\partial_x \Phi(x)]^2 \} - \frac{h\lambda}{\pi a_0} \int dx \sin\sqrt{2}\pi\Phi - 2NJ_\perp m_0^2. \quad (54)$$

Following through the same steps as in the spin-Peierls case we find the following mean-field results for staggered magnetization and mass gap:

$$m_0 = C \left| \frac{J_\perp}{J} \right|^{1/2}, \quad M = C' |J_\perp|, \quad (55)$$

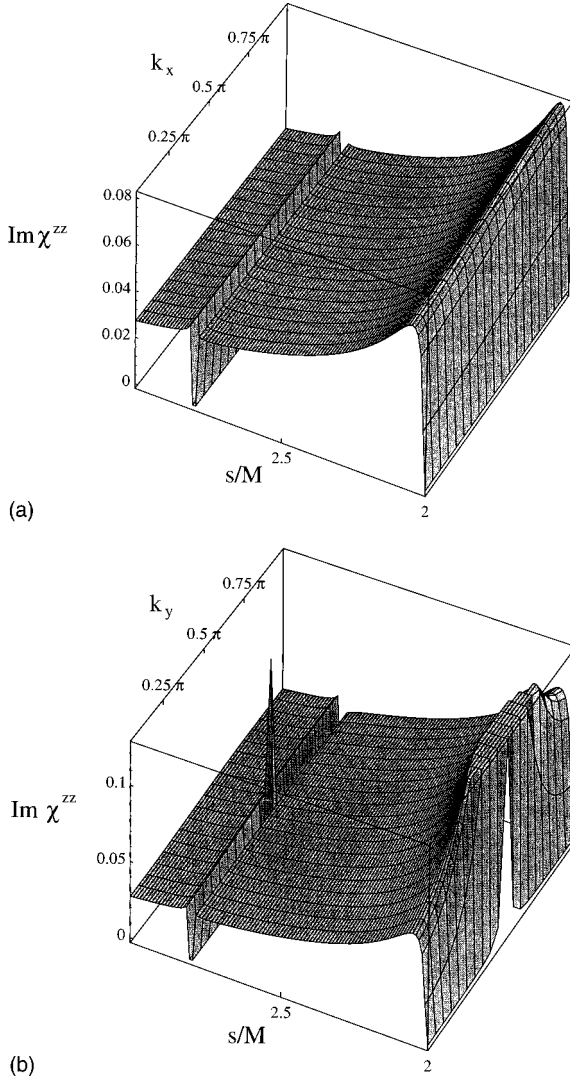

FIG. 4. Imaginary part (in arbitrary units) of $\chi^{zz}(\omega, q; \vec{k})$ in x (a) and y (b) directions.

where the ratio of C and C' is given by Eq. (15). This relation can be used to determine the transverse coupling J_{\perp} in terms of J and the directly measurable quantities M and m_0 as follows. The gap M is equal to $\omega(\pi, 0, \pi)$ which is found experimentally to be 11.0 ± 0.5 MeV in KCuF_3 .⁵ The average magnetic moment is $m_0 \approx 0.27$ (Ref. 6) and $J \approx 53.17 \pm 0.25$ MeV.⁷ Using these values we find

$$|J_{\perp}| = \frac{1}{J} \left(\frac{CM}{C'm_0} \right)^2 \approx 0.96 \text{ MeV}. \quad (56)$$

Let us now turn to the correlation functions for a single chain. The correlator $\langle\langle S^z S^z \rangle\rangle$ at small q is still given by Eq. (29), but for $q \approx \pi$ is given by Eq. (47). Therefore around $q = \pi$ the pole is at $s = \sqrt{3}M$:

$$\chi^{zz}(\omega, q) \equiv D^{\cos}(s) = \frac{2F_2^2}{3M^2 + v^2/a_0^2(\pi - q)^2 - \omega^2} + \text{incoherent}, \quad (57)$$

where ‘‘incoherent’’ denotes multiparticle contributions. Some of these are determined exactly in Appendix A. A plot of $D^{\cos}(s)$ is shown in Fig. 2.

Correlation functions of transverse components of the staggered magnetization are given by Eq. (44) and have a pole at $s = M$

$$\chi^{xx}(\omega, q) \equiv D^{\sin}(s) = \frac{2F_1^2}{M^2 + v^2/a_0^2(\pi - q)^2 - \omega^2} + \text{incoherent}. \quad (58)$$

Here we have used the fact that in the continuum model the correlation functions of $\cos \sqrt{2\pi}\theta$, $\sin \sqrt{2\pi}\theta$, and $\sin \sqrt{2\pi}\Phi$ are equal due to the $\text{SU}(2)$ symmetry present at $\beta = \sqrt{2\pi}$. A plot of $D^{\sin}(s)$ is shown in Fig. 1.

The difference in the correlation functions (57) and (58) is obviously related to the broken rotational symmetry of the Hamiltonian (7). Next we take into account the interchain interaction by an RPA analysis. This yields the following expression for the longitudinal dynamical susceptibility:

$$\chi^{zz}(\omega, q, \vec{k}) = \frac{D^{\cos}(s)}{1 - 2|J_{\perp}|(\cos k_x + \cos k_y)D^{\cos}(s)},$$

$$\chi^{xx}(\omega, q, \vec{k}) = \frac{D^{\sin}(s)}{1 - 2|J_{\perp}|(\cos k_x + \cos k_y)D^{\sin}(s)}. \quad (59)$$

Here we again have taken into account only the staggered part of the spin density as it gives the most relevant contribution to the interchain interaction. As a result the RPA expression for the susceptibilities are of scalar rather than matrix form.¹¹ The transverse susceptibility must have a pole at the Néel wave vector $(0, 0, \pi)$ as the spin $\text{SU}(2)$ symmetry is spontaneously broken. This leads to the requirement that

$$D^{\sin}(0) = \frac{1}{4|J_{\perp}|} \approx 0.12509 \frac{Z}{M^2}, \quad (60)$$

which fixes the normalization Z in terms of the transverse coupling and the breather mass as $Z \approx 1.999M^2/|J_{\perp}|$. The normalization of the correlator of cosines then follows to be

$$D^{\cos}(0) \approx \frac{0.07443}{|J_{\perp}|}. \quad (61)$$

The Goldstone mode associated with the zero energy pole in χ^{\perp} is a spin wave moving in the z direction and its dispersion is found from the singularities of χ^{\perp} . Due to Lorentz invariance D^{\sin} depends only on s rather than on ω and q independently. This immediately implies that the spin-wave dispersion for $q \approx \pi$ is

$$\omega^2(q, \vec{k}) = \frac{v^2}{a_0^2}(\pi - q)^2 + M^2 \left(1 - \frac{\cos k_x + \cos k_y}{2} \right)$$

$$\approx \frac{\pi^2 J^2}{4}(\pi - q)^2 + M^2 \left(1 - \frac{\cos k_x + \cos k_y}{2} \right). \quad (62)$$

This is in very good agreement with experiment being almost identical to the fit used in Ref. 5. In Fig. 5(a) we plot the spin-wave dispersion for $k_y = 0$ and $k_x \in (0, \pi)$.

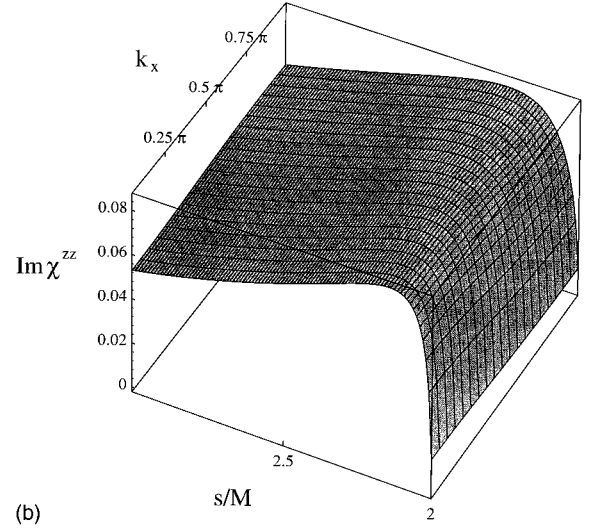
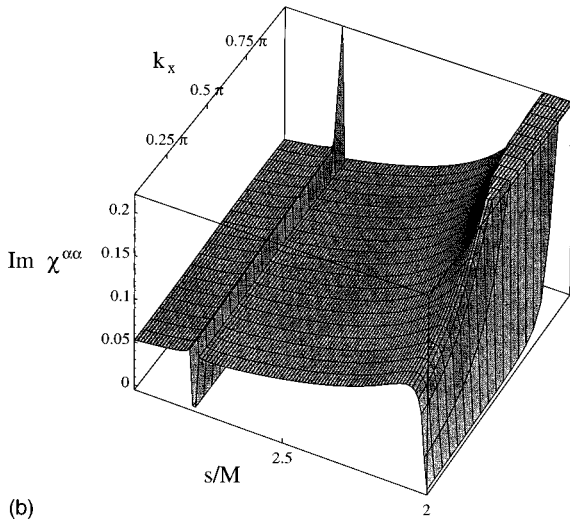
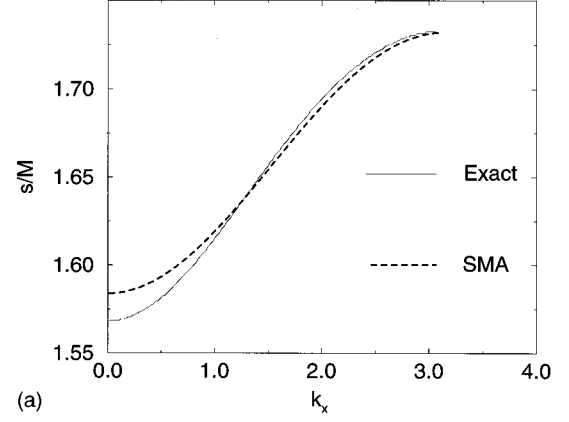
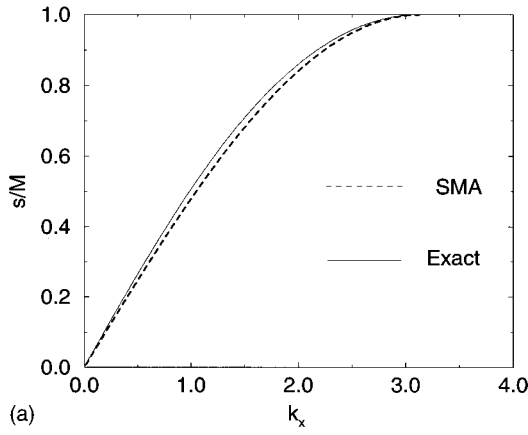

FIG. 5. (a) Spin-wave dispersion as a function of k_x for $k_y=0$. (b) Imaginary part (in arbitrary units) of χ^\perp for $s>2$ as a function of k_x for $k_y=0$.

FIG. 6. (a) Dispersion of the longitudinal mode as a function of k_x for $k_y=0$. (b) Imaginary part (in arbitrary units) of χ^{zz} for $s\geq 2$ as a function of k_x for $k_y=0$.

We see that the SMA works extremely well for all values of k_x . The imaginary part of the dynamical susceptibility is directly measurable by neutron scattering. We find

$$\text{Im}\chi^\perp(\omega, q, \vec{k}) = \frac{\pi}{2|J_\perp|} \delta\left(\frac{s^2}{M^2} - 1 + \frac{\cos k_x + \cos k_y}{2}\right) + \text{incoherent}, \quad (63)$$

where we have used the SMA to get the δ function part. The incoherent part is plotted in Fig. 5(b). We see that there is in general no singularity at the threshold of the light breather-heavy breather continuum except at $k_x \rightarrow \pi$ where $\text{Im}\chi^\perp(\omega, q, \vec{k}) \equiv \text{Im}D^{\text{sin}}(\omega, q)$ so that we recover the pure 1D result. The situation for the soliton-antisoliton continuum is analogous.

Let us now turn to the longitudinal susceptibility. In the SMA there is a pole in χ^{zz} at

$$\omega^2(q, \vec{k}) = \frac{v^2}{a_0^2} (\pi - q)^2 + M^2 \left[3 - \frac{\gamma}{2} (\cos k_x + \cos k_y) \right], \quad (64)$$

where γ is given by Eq. (48). This is compared to the exact result for the case where $k_y=0$ in Fig. 6(a). We see that the

corrections to the SMA result are very small.

Using the SMA [which we know from Fig. 6(a) to be an excellent approximation] to extract the coherent delta-function part we find

$$\text{Im}\chi^{zz}(\omega, q, \vec{k}) = \frac{\pi\gamma}{4|J_\perp|} \delta\left(\frac{s^2}{M^2} - 3 + \frac{\gamma}{2} (\cos k_x + \cos k_y)\right) + \text{incoherent}. \quad (65)$$

The incoherent part is plotted in Fig. 6(b).

ACKNOWLEDGMENTS

We thank R. Cowley, S. Nagler, L.-P. Regnault, and F. Smirnov for interesting and valuable conversations.

APPENDIX A: MULTIPARTICLE FORM FACTORS

In this appendix we consider multiparticle form factors. We start with two-soliton two-antisoliton form factors and explicitly derive the related three- and two-particle form factors. The extension to n -soliton n -antisoliton form factors ($n=3,4,\dots$) is straightforward and will not be discussed

here. The form-factor expansion for two-point correlation functions is found to be rapidly converging and for small s it is essentially sufficient to take into account two-particle form factors only. Note that most of the formulas below are to be understood in terms of analytic continuation of $\zeta(\theta)$. A useful formula is

$$\begin{aligned} & |\zeta(\theta+i\alpha)\zeta(\theta-i\alpha)|^2 \\ &= \frac{c^4}{4} (\cosh\theta - \cos\alpha)^2 \exp\left\{4 \int_0^\infty dx \frac{\cosh x/6}{x \sinh x \cosh(x/2)}\right. \\ &\quad \left. \times \left(1 - \cos \frac{x\theta}{\pi} \cosh \frac{\pi-\alpha}{\pi} x\right)\right\} \\ &\quad \times \frac{\sinh^2\theta \cos^2\alpha + [\cosh\theta \sin\alpha - \sin(\pi/3)]^2}{\sinh^2\theta \cos^2\alpha + [\cosh\theta \sin\alpha + \sin(\pi/3)]^2}. \quad (\text{A1}) \end{aligned}$$

Multiparticle form factors of (quasi)local operators were studied in detail by Smirnov.²⁷ From his work the two-soliton two-antisoliton form factor for $\cos\sqrt{2\pi}\Phi$ is straightforwardly extracted:

$$\begin{aligned} & F^{\cos}(\theta_1, \theta_2, \theta_3, \theta_4)_{--++} \\ &= \langle 0 | \cos\sqrt{2\pi}\Phi | \theta_1, \theta_2, \theta_3, \theta_4 \rangle_{--++} \\ &= 2\pi(2d)^2 \sqrt{Z} 3 \left(\sum_{i=1}^4 e^{\theta_i} \right) \\ &\quad \times \left(\sum_{m=1}^4 e^{-\theta_m} \right) \sum_{i<j} e^{\theta_i+\theta_j} \prod_{i<k} \zeta(\theta_i-\theta_k) e^{-1/2\sum_j \theta_j} \\ &\quad \times \cosh \frac{3}{2}(\theta_3+\theta_4-\theta_1-\theta_2) \prod_{i=1}^2 \prod_{j=3}^4 \frac{1}{\sinh 3(\theta_j-\theta_i)}. \quad (\text{A2}) \end{aligned}$$

Orderings other than $--++$ are obtained from Eq. (A2) by using the generalization of Eq. (33), e.g.,

$$\begin{aligned} & F^{\cos}(\theta_1, \theta_2, \theta_3, \theta_4)_{-++-} \\ &= S_0(\theta_3-\theta_2) F^{\cos}(\theta_1, \theta_3, \theta_2, \theta_4)_{--++}. \quad (\text{A3}) \end{aligned}$$

It is easy to verify that the soliton-antisoliton form factor of $\cos\sqrt{2\pi}\Phi$ is obtained from Eq. (A2) via the annihilation pole condition (41). The two-soliton two-antisoliton form factor for $\sin\sqrt{2\pi}\Phi$ is very similar to the one for $\cos\sqrt{2\pi}\Phi$

$$\begin{aligned} & F^{\sin}(\theta_1, \theta_2, \theta_3, \theta_4)_{--++} = -i \tanh \frac{3}{2}(\theta_3+\theta_4-\theta_1-\theta_2) \\ &\quad \times F^{\cos}(\theta_1, \theta_2, \theta_3, \theta_4)_{--++}. \quad (\text{A4}) \end{aligned}$$

The residue at the annihilation pole (times i) now yields the soliton-antisoliton form factor of $\sin\sqrt{2\pi}\Phi$.

Breather form factors are obtained from the residues of Eq. (A2) at its poles. In the soliton-antisoliton-even breather sector we find

$$\begin{aligned} & F^{\cos}(\theta_1, \theta_2, \theta_3)_{-+2} \\ &= -2\pi \frac{(2d)^2 \sqrt{Z}}{2^{3/2} 3^{1/4}} \frac{e^{-1/2(\theta_1+\theta_2)-\theta_3}}{\cosh(3\theta_{21}/2) \cosh 3\theta_{31} \cosh 3\theta_{32}} \\ &\quad \times \zeta(\theta_{12}) \zeta\left(-i\frac{\pi}{3}\right) \zeta\left(\theta_{13}+i\frac{\pi}{6}\right) \zeta\left(\theta_{13}-i\frac{\pi}{6}\right) \\ &\quad \times \zeta\left(\theta_{23}+i\frac{\pi}{6}\right) \zeta\left(\theta_{23}-i\frac{\pi}{6}\right) [e^{\theta_1}+e^{\theta_2}+\sqrt{3}e^{\theta_3}] \\ &\quad \times [e^{-\theta_1}+e^{-\theta_2}+\sqrt{3}e^{-\theta_3}] \\ &\quad \times [e^{\theta_1+\theta_2}+\sqrt{3}e^{\theta_3}(e^{\theta_1}+e^{\theta_2})+e^{2\theta_3}]. \quad (\text{A5}) \end{aligned}$$

The corresponding form factor for $\sin\sqrt{2\pi}\Phi$ is

$$F^{\sin}(\theta_1, \theta_2, \theta_3)_{-+2} = -i \coth \frac{3\theta_{21}}{2} F^{\cos}(\theta_1, \theta_2, \theta_3)_{-+2}, \quad (\text{A6})$$

and different orderings are obtained by the appropriate generalization of Eq. (33), e.g.,

$$F^{\cos}(\theta_1, \theta_2, \theta_3)_{2-+} = F^{\cos}(\theta_2, \theta_3, \theta_1)_{-+2} S_{1,2}(\theta_{21}) S_{1,2}(\theta_{31}). \quad (\text{A7})$$

The residue at the annihilation pole (times i) in $F^{\cos}(\theta_1, \theta_2, \theta_3)_{2-+}$ gives the heavy breather form factor F_2 . The corresponding sin form factor has no annihilation poles. In the soliton-antisoliton-odd breather sector we obtain

$$\begin{aligned} & F^{\cos}(\theta_1, \theta_2, \theta_3)_{-+1} \\ &= -2\pi \frac{(2d)^2 \sqrt{Z}}{2^{3/2} 3^{1/4}} \frac{e^{-1/2(\theta_1+\theta_2)-\theta_3}}{\sinh(3\theta_{21}/2) \sinh 3\theta_{31} \sinh 3\theta_{32}} \\ &\quad \times \zeta(\theta_{12}) \zeta\left(-i\frac{2\pi}{3}\right) \zeta\left(\theta_{13}+i\frac{\pi}{3}\right) \zeta\left(\theta_{13}-i\frac{\pi}{3}\right) \\ &\quad \times \zeta\left(\theta_{23}+i\frac{\pi}{3}\right) \zeta\left(\theta_{23}-i\frac{\pi}{3}\right) [e^{\theta_1}+e^{\theta_2}+e^{\theta_3}] \\ &\quad \times [e^{-\theta_1}+e^{-\theta_2}+e^{-\theta_3}] \\ &\quad \times [e^{\theta_1+\theta_2}+e^{\theta_3}(e^{\theta_1}+e^{\theta_2})+e^{2\theta_3}] \\ &= i \coth \frac{3\theta_{21}}{2} F^{\sin}(\theta_1, \theta_2, \theta_3)_{-+1}. \quad (\text{A8}) \end{aligned}$$

From the residues at the poles of Eq. (A8) we can derive the breather-breather form factors

$$\begin{aligned} & F^{\cos}(\theta_1, \theta_2)_{11} \\ &= -2\pi \frac{4(2d)^2 \sqrt{Z}}{3^{3/2}} \frac{[\cosh(\theta_{12}/2)]^2 [\cosh\theta_{12}+1/2]}{(\sinh 3\theta_{12})^2} \\ &\quad \times \zeta^2(\theta_{21}) \zeta^2\left(-i\frac{2\pi}{3}\right) \zeta\left(\theta_{21}+i\frac{2\pi}{3}\right) \zeta\left(\theta_{21}-i\frac{2\pi}{3}\right) \\ &\quad \times S_0\left(\theta_{21}+i\frac{\pi}{3}\right) S_0\left(\theta_{21}-i\frac{\pi}{3}\right). \quad (\text{A9}) \end{aligned}$$

This is identical to the soliton-antisoliton form factor $F^{\cos}(\theta_1, \theta_2)_{-+}$ as can be proved by direct calculation. Some

useful identities are $S_0[\theta + i(\pi/3)]S_0[\theta - i(\pi/3)] = S_0(\theta)$, $2\zeta(\theta)\zeta(\theta - i\pi) = \sinh 3\theta / \sinh \theta + i \sin(\pi/3)$ and

$$\exp\left(\int_0^\infty \frac{dx}{x} \frac{\cosh(x/6) - \cosh(x/2)}{\sinh x \cosh(x/2)}\right) = \frac{2\sqrt{2}}{c}. \quad (\text{A10})$$

The other breather-breather form factors are given by

$$\begin{aligned} F^{\cos}(\theta_1, \theta_2)_{22} &= -2\pi \frac{4(2d)^2 \sqrt{Z} [\cosh(\theta_{12}/2)]^2 [\cosh \theta_{12} + 3/2]}{\sqrt{3} (\cosh 3\theta_{12})^2} \\ &\quad \times \zeta^2(\theta_{12}) \zeta^2\left(-i\frac{\pi}{3}\right) \zeta\left(\theta_{12} + i\frac{\pi}{3}\right) \zeta\left(\theta_{12} - i\frac{\pi}{3}\right), \\ F^{\sin}(\theta_1, \theta_2)_{21} &= -2\pi \frac{4(2d)^2 \sqrt{Z}}{3^{3/2}} \\ &\quad \times \frac{(\cosh \theta_{12} + \sqrt{3}/2)[1 + \sqrt{3}/2 \cosh \theta_{12}]}{(\cosh 3\theta_{12})^2} \\ &\quad \times \zeta\left(-i\frac{\pi}{3}\right) \zeta\left(-i\frac{2\pi}{3}\right) \zeta\left(\theta_{12} + i\frac{\pi}{2}\right) \\ &\quad \times \zeta\left(\theta_{12} - i\frac{\pi}{2}\right) \zeta\left(\theta_{12} + i\frac{\pi}{6}\right) \zeta\left(\theta_{12} - i\frac{\pi}{6}\right). \quad (\text{A11}) \end{aligned}$$

The special values of ζ at the breather poles are given by $\zeta[-i(\pi/3)] \approx -1.10184i$ and $\zeta[-i(2\pi/3)] \approx -2.72272i$. We note that $\zeta[-i(\pi/3)]\zeta[-i(2\pi/3)] = -3$.

It is apparent that n -particle form factors depend only on $n-1$ independent rapidity variables. This fact can be used to essentially simplify expressions such as (26) for correlation functions. For example, two-particle contributions for $\omega \geq 0$ are given by

$$\begin{aligned} D^{\cos}(\omega, q)|_{2 \text{ part}} &= -\int_0^\infty \frac{d\theta}{\pi} \left\{ \frac{2|F^{\cos}(\theta)_{+-}|^2 + |F^{\cos}(\theta)_{11}|^2}{s^2 - 4M^2 \cosh^2(\theta/2) + i\varepsilon} \right. \\ &\quad \left. + \frac{|F^{\cos}(\theta)_{22}|^2}{s^2 - 12M^2 \cosh^2(\theta/2) + i\varepsilon} \right\}, \\ D^{\sin}(\omega, q)|_{2 \text{ part}} &= -\int_0^\infty \frac{d\theta}{\pi} \left\{ \frac{2|F^{\sin}(\theta)_{+-}|^2}{s^2 - 4M^2 \cosh^2(\theta/2) + i\varepsilon} \right. \\ &\quad \left. + \frac{2|F^{\sin}(\theta)_{21}|^2}{s^2 - 4M^2 [1 + (\sqrt{3}/2) \cosh \theta] + i\varepsilon} \right\}, \quad (\text{A12}) \end{aligned}$$

where we also have made use of various symmetry properties of the form factors in order to perform the sum over ϵ_j . Similarly the contribution of form factors involving one soliton, one antisoliton, and one (light) breather of type 1 can be brought to the form

$$-\int_{-\infty}^\infty \frac{d\theta}{2\pi} \int_{-\infty}^\infty \frac{d\theta_{12}}{2\pi} \frac{2}{s^2 - M^2 \{1 + 4 \cosh \theta \cosh(\theta_{12}/2) + [2 \cosh(\theta_{12}/2)]^2\}} |F^{\cos}(\theta, \theta_{12})_{-+1}|^2, \quad (\text{A13})$$

where

$$\begin{aligned} F^{\cos}(\theta, \theta_{12})_{-+1} &= -2\pi \frac{(2d)^2 \sqrt{Z} [2 \cosh(\theta_{12}/2) + e^\theta][2 \cosh(\theta_{12}/2) + e^{-\theta}][2 \cosh(\theta_{12}/2) + 2 \cosh \theta]}{2^{3/2} 3^{1/4} \sinh 3(\theta_{12}/2) \sinh 3(\theta + \theta_{12}/2) \sinh 3(\theta - \theta_{12}/2)} \zeta(\theta_{12}) \zeta\left(-i\frac{2\pi}{3}\right) \\ &\quad \times \zeta\left(\frac{\theta_{12}}{2} - \theta - i\frac{\pi}{3}\right) \zeta\left(\frac{\theta_{12}}{2} - \theta + i\frac{\pi}{3}\right) \zeta\left(\frac{\theta_{12}}{2} + \theta - i\frac{\pi}{3}\right) \zeta\left(\frac{\theta_{12}}{2} + \theta + i\frac{\pi}{3}\right). \quad (\text{A14}) \end{aligned}$$

- ¹M. Hase, I. Terasaki, and K. Uchinokura, Phys. Rev. Lett. **70**, 3651 (1993).
²J. P. Pouget, L. P. Regnault, A. Ain, B. Hennion, J. P. Renard, P. Veillet, G. Dhahenne, and A. Revcolevschi, Phys. Rev. Lett. **72**, 4037 (1994).
³K. Hirota *et al.*, Phys. Rev. Lett. **73**, 736 (1994).
⁴L. P. Regnault, A. Ain, B. Hennion, G. Dhahenne, and A. Revcolevschi, Phys. Rev. B **53**, 5579 (1996).
⁵S. K. Satija, J. D. Axe, G. Shirane, H. Yoshizawa, and K. Hirakawa, Phys. Rev. B **21**, 2001 (1980).
⁶D. J. Welz, J. Phys.: Condens. Matter **5**, 3643 (1993).
⁷D. A. Tennant, S. E. Nagler, S. Welz, G. Shirane, and K. Yamada, Phys. Rev. B **52**, 13 381 (1995); D. A. Tennant, R. Cowley, S. E. Nagler, and A. M. Tsvelik, *ibid.* **52**, 13 368 (1995).
⁸A. W. Garrett, S. E. Nagler, D. A. Tennant, B. S. Sales, and T. Barnes, Phys. Rev. Lett. **79**, 745 (1997).
⁹D. C. Dender, P. R. Hammar, D. H. Reich, C. Broholm, and G.

Aeppli, Phys. Rev. Lett. (to be published).

- ¹⁰K. Hirota, B. Shirane, Q. J. Harris, Q. Feng, R. J. Birgeneau, M. Hase, and K. Uchinokura, Phys. Rev. B **52**, 15 412 (1995).
¹¹H. Schulz, Phys. Rev. Lett. **77**, 2790 (1996).
¹²R. Julien and F. D. M. Haldane, Bull. Am. Phys. Soc. **28**, 34 (1983); S. Eggert and I. Affleck, Phys. Rev. B **46**, 10 866 (1992).
¹³A. M. Tsvelik, *Quantum Field Theory in Condensed Matter Physics* (Cambridge University Press, Cambridge, England, 1995).
¹⁴T. Nakano and H. Fukuyama, J. Phys. Soc. Jpn. **50**, 2489 (1981).
¹⁵S. Coleman, Ann. Phys. (N.Y.) **101**, 239 (1976).
¹⁶F. D. M. Haldane, Phys. Rev. B **25**, 4925 (1982).
¹⁷D. G. Shelton, A. A. Nersisyan, and A. M. Tsvelik, Phys. Rev. B **53**, 8521 (1996).
¹⁸A. M. Tsvelik, Phys. Rev. B **45**, 486 (1992).
¹⁹G. S. Uhrig and H. J. Schulz, Phys. Rev. B **54**, 9624 (1996).
²⁰V. E. Korepin and L. D. Faddeev, Theor. Math. Phys. **25**, 1039

- (1975); R. Dashen, B. Hasslacher, and A. Neveu, Phys. Rev. D **11**, 3424 (1975).
- ²¹Al. B. Zamolodchikov, Int. J. Mod. Phys. A **10**, 1125 (1995).
- ²²A. B. Zamolodchikov, JETP Lett. **25**, 468 (1977).
- ²³M. Karowski, H.-J. Thun, T. T. Truong, and P. H. Weisz, Phys. Lett. **67B**, 321 (1977).
- ²⁴I. Affleck, Nucl. Phys. B **265**, 448 (1986).
- ²⁵A. B. Zamolodchikov and Al. B. Zamolodchikov, Ann. Phys. (N.Y.) **120**, 253 (1979).
- ²⁶M. Karowski and P. Weisz, Nucl. Phys. B **139**, 455 (1978).
- ²⁷F. A. Smirnov, *Form Factors in Completely Integrable Models of Quantum Field Theory* (World Scientific, Singapore, 1992).
- ²⁸G. Delfino and G. Mussardo, Nucl. Phys. B **455**, 724 (1996).
- ²⁹G. Delfino, P. Simonetti, and J. L. Cardy, Phys. Lett. B **387**, 327 (1996).
- ³⁰X. G. Wen, Phys. Rev. B **42**, 6623 (1990).
- ³¹F. H. L. Essler and A. M. Tsvelik (unpublished).