

Energy and angular distributions of excited rhodium atoms ejected from the rhodium (100) surface

M. El-Maazawi, R. Maboudian, Z. Postawa,* and N. Winograd

Department of Chemistry, The Pennsylvania State University, University Park, Pennsylvania 16802

(Received 28 January 1991)

Multiphoton resonance ionization spectroscopy has been used to determine the polar-angle and the kinetic-energy distributions of Rh atoms desorbed from the ion-bombarded Rh{100} surface in the fine-structure components of the a^4F_J ground-state multiplet ($J = \frac{3}{2}$ and $\frac{1}{2}$). The overall behavior is found to be very similar to that observed for higher-lying metastable levels. The energy distribution of the metastable level ($^4F_{7/2}$ with excitation energy of ~ 0.2 eV) is found to be broader than the ground-state ($^4F_{9/2}$) distribution. The energy distribution of the excited ejected atoms is shown to depend mainly on the electron configuration of the excited state. The measured spectra have also been used to investigate the dependence of the excitation probability on the emission velocity. It is shown that the excitation probability depends strongly on this parameter, approaching an exponential dependence on the reciprocal of the normal component of velocity at higher velocities ($> 5 \times 10^5$ cm/sec).

INTRODUCTION

Energetic-ion bombardment of solid surfaces gives rise to a wide variety of processes.¹ Of particular interest is the ejection of electronically excited target atoms. To investigate the ejection mechanism of the excited-state atoms, the spatial distribution²⁻⁴ and the Doppler-broadened line-shape profile^{5,6} of the emitted light were originally measured and used to determine the energy distributions of the ejected excited particles. With these techniques, extremely high values of mean kinetic energies (1-2 orders-of-magnitude higher than that for the ground state) were obtained. However, these measurements were complicated by poor spatial resolution and by disregarding the effects of cascade transitions. More sophisticated Doppler-shift laser-induced-fluorescence (DSLIF) spectroscopy has been used recently to measure the velocity distribution of atoms desorbed in various metastable states.⁷⁻¹² With this technique, the energy distributions of atoms ejected in sublevels of the ground-state multiplet or in low-lying excited states (with excitation energies E_i less than 1 eV) were found to be identical to the ground-state distribution.^{7,10} Metastable particles with excitation energies above 1 eV were also investigated and shown to have broader energy distributions than the ground state with the most probable energies 3-4 times higher than the sputtered ground-state atoms.^{8,9} From the theoretical standpoint several models have been proposed. Some of these include the existence of a radiationless deexcitation process near the surface,^{13,14} resonance neutralization of sputtered ions into excited neutrals in the vicinity of the surface,¹⁵ and excitation via inelastic energy transfer to a target atom in the final collision leading to ejection.¹⁶

The difference in behavior between the low- ($E_i < 1$ eV) and the high-lying ($E_i > 1$ eV) excited states has led to the belief that the excitation energy is the main factor which determines the shape of the excited-state energy distribution relative to the ground state.¹⁰ Recently, Craig *et al.*¹⁷ proposed a deexcitation model for sputtered excited neutral atoms based on the electronic localization

of the fine-structure orbital. This model suggests that the degree of deexcitation of an atom departing in an excited-state depends mainly on the extent of interaction between its electrons that determine the fine-structure states and the metal conduction band. Based on this picture, when these electrons are well shielded, the relaxation processes have long lifetimes and the energy distribution becomes independent of the atomic state. On the other hand, for partially shielded and exposed cases, the final-state population and the energy distribution reflect both the initial excitation process and the deexcitation as the atoms leave the surface region.

In this Rapid Communication, we employ multiphoton resonance ionization (MPRI) to examine the effect of electron configuration on the energy distribution of Rh atoms sputtered in an excited state. Although the $^4F_{7/2}$ fine-structure component of Rh ground-state multiplet has an excitation energy of only ~ 0.2 eV, its electron configuration falls into the partial-shielding regime. Such a system allows us to investigate the factors that affect the energy distribution of the excited atoms. Furthermore, the distributions are used to determine the functional dependence of the excitation probability on the emission velocity. It is found that for velocities greater than 5×10^5 cm/sec, the excitation probability depends exponentially on the reciprocal of the normal component of velocity but deviates from this behavior at lower velocities.

EXPERIMENTAL SETUP

The Rh sample is an optically polished single crystal of 99.99% purity oriented to within $\pm 0.5^\circ$ of the (100) face. The cleaning procedure¹⁸ and the experimental setup¹⁹ have been described elsewhere. Briefly, the measurements are performed in an ultrahigh vacuum chamber (2.0×10^{-10} Torr base pressure) equipped with a low-energy-electron diffraction and Auger surface analysis system. To initiate an event, a 200-nsec pulse of 5-keV Ar⁺ is focused, at normal incidence, onto a 2-mm spot on the sam-

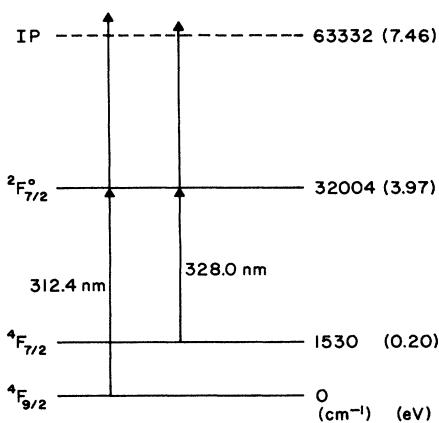

FIG. 1. Schematic energy-level diagram of a rhodium atom illustrating the MPRI schemes used to ionize Rh in the ${}^4F_{7/2}$ excited state and in the ${}^4F_{9/2}$ ground state. IP represents the first ionization potential of Rh atom.

ple. A given time after the ion impact, a ribbon-shaped laser pulse (1 mJ for 6 nsec) is used to ionize a small volume of the desorbed particles, thus defining the time of flight (TOF) of the probed species. The MPRI technique is employed to selectively ionize the ejected particles. As is illustrated in Fig. 1, the ionization schemes used in the present investigation involve a one-photon excitation to the $z^2F_{7/2}^\circ$ level followed by subsequent ionization via a second photon absorption. Although the resonant transitions $a^4F_J \rightarrow z^2F_{7/2}^\circ$ ($J = \frac{9}{2}$ and $\frac{7}{2}$) violate the spin selection rule, this condition holds only under the assumption of vanishing L - S coupling which becomes less rigorous as the atomic number increases.²⁰ For a Rh atom (102.9 amu), this transition is experimentally found to be rather intense and the choice of the resonant step is justified in view of the laser-induced power broadening of that step.¹⁹ Once the particles are ionized, they are accelerated toward a position-sensitive microchannel plate detector and are displayed on the phosphorous screen located in the back of it. The image is, in turn, monitored by a charge-coupled-device camera which is interfaced to a micro-VAX station II computer for data storage and processing. For a typical spectrum, 30–60 images, each corresponding to a different TOF, are collected and sorted into an intensity map of kinetic energies and takeoff angles.

RESULTS AND DISCUSSION

The angle-integrated energy distributions of Rh atoms ejected from the Rh{100} surface in two of the fine-structure levels of the 4F_J ground-state multiplet ($J = \frac{9}{2}$ and $\frac{7}{2}$) are shown in Fig. 2. It is clear that the energy distribution of the excited Rh (${}^4F_{7/2}$ with $E_i \sim 0.2$ eV) atoms is broader than that of the ground state. This is in contrast to the energy distributions previously observed for atoms sputtered in various low-lying excited states.^{7,11} It is hard to reconcile this difference if the excitation energy is considered to be the major factor in determining the shape of the excited-state distribution. However, based on the orbital deexcitation model,¹⁷ all the previously studied

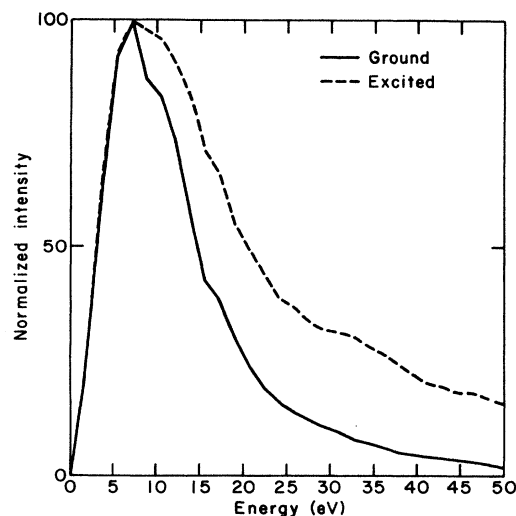

FIG. 2. Experimental angle-integrated energy distributions of the ground-state (solid curve) and excited-state (dashed curve) Rh atoms ejected from ion-bombarded Rh{100} surface in the (010) plane. The distributions are normalized to the peak intensity.

low-lying states have well-shielded electron configuration and hence, are expected to behave similarly to the ground state. The $a^4F_{7/2}$ ($4d^85s^1$) level of a Rh atom falls in the partial-shielding regime. This, in-turn, allows a partial nonradiative quenching of the excited atom. Consequently, the energy distribution reflects both the initial excitation process as well as the deexcitation process.

The angular distributions of the ground-state and the excited-state Rh atoms ejected from Rh{100} in the (010) plane are presented in Fig. 3. The ground-state angular distributions have already been presented and explained using molecular-dynamics computer simulations of the ejection process.¹⁸ It was shown that the geometrical structure of the near-surface region influences the polar-angle distributions in a detailed way. This structural sensitivity was shown to be a consequence of the surface atoms being channeled and blocked in particular directions along the surface while desorbing.

As is evident in Fig. 3, the ratio of the intensity in the normal direction to that in the off-normal peak is considerably higher in the excited-state distribution. Moreover, the off-normal peak in the metastable distribution occurs closer to the surface normal than in the ground-state distribution. Our independent measurement of the energy-resolved angular distributions of the ground state and the metastable state allows the determination of the angular and the velocity dependence of the excitation probability. In the present setup, the absolute yields cannot be measured. However, one can estimate the relative population of the two levels if the ionization efficiencies are assumed to be the same. This is a reasonable assumption since the signal intensity is measured to depend linearly on the laser power. In a two-photon ionization scheme, this implies that the first transition is saturated and hence the ionization process is determined by the ionization efficiency of the intermediate excited state. In the present experiment,

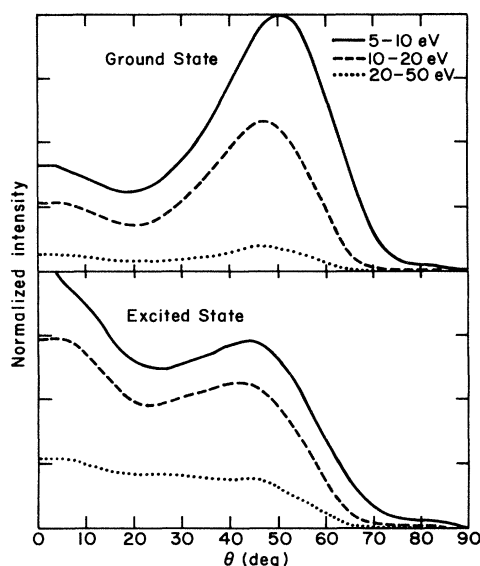

FIG. 3. Measured angular distributions of Rh atoms ejected from Rh{100} surface in the (010) plane. The top curves correspond to the ground-state distributions and the bottom plots to the excited-state distributions for 5–10 eV (solid), 10–20 eV (dashed), and 20–50 eV (dotted) energy ranges, respectively.

this level was chosen to be the same for the two states probed (Fig. 1). Therefore, it suffices to normalize the measured intensities to the laser power in order to compare the population of each level.

The relative yield of the $a^4F_{7/2}$ state to the $a^4F_{9/2}$ state is determined to be about ~ 0.05 . Since the population density is found to decrease exponentially with the excitation energy,^{7,11,21,22} the cascade transitions are assumed to be insignificant in our measurements. Hence, the measured intensity is directly proportional to the number density of the ejected atoms. In other words, the ratio of the excited-state signal to that of the ground state is proportional to the final probability of excitation into the $a^4F_{7/2}$ state during the ejection process.

It has been proposed^{3,8,13,23} that the excitation probability has the $\exp[-A/(av_{\perp})]$ functional form, where A is a transition rate, $1/a$ is a characteristic distance of atom-surface interaction, and v_{\perp} is the velocity component normal to the surface. In Fig. 4, the ratio of the excited-state distribution to the ground-state distribution is plotted as a function of $1/v_{\perp}$ for atoms ejected close to the surface normal ($\theta < 10^\circ$). The behavior approaches an exponential dependence on $1/v_{\perp}$ for velocities greater than $\sim 5 \times 10^5$ cm/sec. The coefficient A/a , obtained from the indicated straight line, is determined to be 1.2×10^6 cm/sec. The deviation at low velocities has been previously observed for excited-state atoms⁸ and for secondary ions.²⁴ This deviation has been attributed to the fact that the atom, while exiting, must overcome the surface binding energy,^{24,25} and hence its velocity near the surface is larger than the measured one. This factor becomes particularly important when the energy of the ejected atom is comparable to the surface binding energy. However, in our measurements the deviation occurs for $E \leq 14$ eV

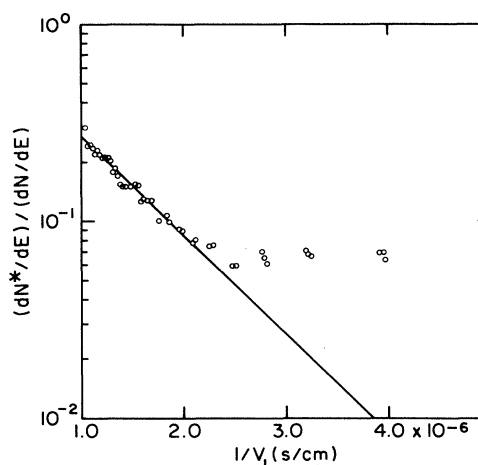

FIG. 4. Ratio of the excited-state distribution dN^*/dE , to the ground-state distribution dN/dE , vs the reciprocal of the normal component of the emission velocity (v) for atoms with $\theta < 10^\circ$. The straight line indicates the best fit to the high-velocity part of the data points.

which is much greater than Rh surface binding energy (5.7 eV). This observation strongly suggests that the binding energy is not the only factor responsible for the deviation at low energies. Molecular-dynamic computer simulations²⁶ suggest that a significant collisional excitation can take place above the surface. Since this process occurs outside the region of effective atom-surface interaction, it has a weak dependence on velocity. This type of excitation becomes more prominent at low velocities for which atoms excited at the surface have a small chance to survive nonradiative deexcitation.

We are currently investigating the polar angle and the azimuthal dependence of the excitation probability. Molecular-dynamics computer simulation has been used successfully to explain the ground-state distributions.¹⁸ The incorporation of the electronic effects into the computer simulation along with our detailed measurements will provide an essential tool for testing the proposed excitation models.

SUMMARY AND CONCLUSIONS

In summary, angle-integrated energy distribution and energy-resolved angular distributions of the $a^4F_{7/2}$ excited-state Rh atoms ejected from ion-bombarded Rh{100} surface have been measured and compared to the $a^4F_{9/2}$ ground-state distributions. This is the first measurement where similar behavior has been observed for a low-lying excited state as compared to a high-lying level. These results show that the electron configuration and not the excitation energy is the main factor in determining the shape of the excited-state energy distribution. In addition, the dependence of the excitation probability on the emission velocity is shown to approach an exponential dependence on the reciprocal of the normal component of velocity. These measurements will provide previously unattainable information about the ejection mechanisms of excited atoms.

ACKNOWLEDGMENTS

The financial support of the U.S. Office of Naval Research and the U.S. National Science Foundation is gratefully acknowledged. The authors express their appreciation to Dr. Dan Bernardo and Professor Barbara J. Garrison for valuable discussions.

-
- *On leave from Institute of Physics, Jagellonian University, ulica Reymonta 4, PL-30-059 Kraków 16, Poland.
- ¹N. Winograd, *Prog. Solid State Chem.* **13**, 285 (1982).
 - ²I. S. Tsong and N. A. Yusuf, *Nucl. Instrum. Methods* **170**, 357 (1980).
 - ³S. Dzioba, O. Auciello, and R. Kelly, *Radiat. Eff.* **45**, 235 (1980).
 - ⁴C. M. Loxton and R. J. MacDonald, *Surf. Sci.* **110**, 339 (1981).
 - ⁵C. Snoek, W. F. van der Weg, and P. K. Rol, *Physica (Utrecht)* **30**, 341 (1964).
 - ⁶W. F. van der Weg and D. J. Bierman, *Physica (Utrecht)* **44**, 206 (1969).
 - ⁷M. J. Pellin, R. B. Wright, and D. M. Gruen, *J. Chem. Phys.* **74**, 6448 (1981).
 - ⁸M. L. Yu, D. Grischkowsky, and A. C. Balant, *Phys. Rev. Lett.* **48**, 427 (1982).
 - ⁹W. Husinsky, G. Betz, and I. Girgis, *Phys. Rev. Lett.* **50**, 1689 (1983).
 - ¹⁰G. Betz, *Nucl. Instrum. Methods Phys. Res. Sect. B* **27**, 104 (1987).
 - ¹¹G. E. Young, M. F. Calaway, M. J. Pellin, and D. M. Gruen, *J. Vac. Sci. Technol. A* **2**, 693 (1984).
 - ¹²W. Husinsky, *J. Vac. Sci. Technol. B* **3**, 1546 (1985).
 - ¹³H. D. Hagstrum, *Phys. Rev.* **96**, 336 (1954).
 - ¹⁴C. W. White, D. L. Simms, N. H. Tolk, and D. V. McCaughan, *Surf. Sci.* **49**, 657 (1975).
 - ¹⁵B. Andresen, S. B. Jensen, P. S. Ramanujam, and E. Veje, *Phys. Scr.* **20**, 65 (1979).
 - ¹⁶R. Kelly, *Phys. Rev. B* **25**, 700 (1982); *Surf. Sci.* **90**, 280 (1979).
 - ¹⁷B. I. Craig, J. P. Baxter, J. Singh, G. A. Schick, P. H. Kobrin, B. J. Garrison, and N. Winograd, *Phys. Rev. Lett.* **57**, 1351 (1986).
 - ¹⁸R. Maboudian, Z. Postawa, M. El-Maazawi, B. J. Garrison, and N. Winograd, *Phys. Rev. B* **42**, 3711 (1990).
 - ¹⁹P. H. Kobrin, G. A. Schick, J. P. Baxter, and N. Winograd, *Rev. Sci. Instrum.* **57**, 1354 (1986).
 - ²⁰I. I. Sobel'man, *Introduction to the Theory of Atomic Spectra* (Pergamon, New York, 1972).
 - ²¹F. M. Kimock, J. P. Baxter, D. L. Pappas, P. H. Kobrin, and N. Winograd, *Anal. Chem.* **56**, 2782 (1984).
 - ²²D. M. Gruen, M. J. Pellin, C. E. Young, M. H. Mendelsohn, and A. B. DeWald, *Phys. Scr.* **T6**, 42 (1983).
 - ²³C. W. White and N. H. Tolk, *Phys. Rev. Lett.* **26**, 486 (1971).
 - ²⁴M. L. Yu, *Phys. Rev. Lett.* **47**, 1325 (1981).
 - ²⁵N. Lang, *Phys. Rev. B* **27**, 2019 (1983).
 - ²⁶D. Bernardo and B. J. Garrison (private communication).