

⁶G. V. Chester, in *Lectures in Theoretical Physics*, edited by K. T. Mahanthappa (Gordon and Breach, New York, 1968), Vol. XI, p. 253.

⁷A preliminary summary of our work has been published: D. Jasnow and M. E. Fisher, *Phys. Rev. Letters* **23**, 286 (1969).

⁸We assume always that the particle (and spin) interaction terms satisfy the appropriate stability and tempering conditions needed to ensure the existence of a sensible thermodynamic limit as explained in Refs. 9 and 10.

⁹M. E. Fisher, *Arch. Ratl. Mech. Anal.* **17**, 337 (1964).

¹⁰D. Ruelle, *Statistical Mechanics: Rigorous Results* (Benjamin, New York, 1969).

¹¹L. D. Landau and E. M. Lifshitz, *Quantum Mechanics* (Pergamon, London, 1958), Secs. 62, 63.

¹²M. E. Fisher, *Rept. Progr. Phys.* **30**, 615 (1967), Sec. 4.3.

¹³R. B. Griffiths, *Phys. Rev.* **152**, 240 (1966).

¹⁴O. Penrose and L. Onsager, *Phys. Rev.* **104**, 576 (1956).

¹⁵C. N. Yang, *Rev. Mod. Phys.* **34**, 694 (1962).

¹⁶T. D. Schultz, D. C. Mattis, and E. H. Lieb, *Rev.*

Mod. Phys. **36**, 856 (1964).

¹⁷M. Suzuki, *Progr. Theoret. Phys. (Kyoto)* **42**, 1086 (1969). The author also generalized the treatment of Ref. 3 to more general order parameters.

¹⁸To illustrate an explicit construction in one dimension, suppose Δ is the interval $|x| \leq c = \frac{1}{2}(1 + \delta)b$. If $f(x) = \exp[-x^{2n}/(1-x^2)]$, then the amplitude

$$a(x) = \int_{-1}^x f(x') dx' / \int_{-1}^1 f(x') dx'$$

is, in fact, infinitely differentiable and furthermore, for large enough n the gradient satisfies

$$\nabla a = da/dx = f(x/c)/c \int_{-1}^1 f(x) dx \leq b^{-1} \leq \frac{1}{2} c^{-1},$$

since the normalizing integral approaches 2 as $n \rightarrow \infty$.

¹⁹This might fail at some special critical- or λ -point transition temperature but will be valid for most other cases of interest.

²⁰The small correction in the brackets of (4.11) and the effect of the terms involving q_3 and q_4 in (4.12) have been neglected in arriving at (4.13).

²¹O. Penrose (unpublished); see also the discussion given in Ref. 6.

Decay of Order in Isotropic Systems of Restricted Dimensionality. II. Spin Systems

Michael E. Fisher* and David Jasnow†

Baker Laboratory, Cornell University, Ithaca, New York 14850

(Received 22 June 1970)

The ordering of one- and two-dimensional spin systems of finite thickness and cross section is considered in the presence and absence of a symmetry-breaking magnetic field. The exchange interactions are allowed to vary randomly or regularly throughout the lattice. It is shown rigorously by applying Bogoliubov's inequality to a subdomain of the system that, provided the (suitably averaged) exchange interactions do not fall off too slowly, no spontaneous ordering can occur. Explicit bounds on the spin-spin correlation function, summed over the sites in a subdomain, are obtained which indicate how the short-range order decays with distance. Detailed numerical plots for the order as a function of the subdomain size are presented for various realistic values of the temperature. Conditions under which these curves yield bounds on the spatial decay of the spin-spin correlation function are also discussed.

I. INTRODUCTION

This paper represents a continuation of the program begun in the previous one¹ (hereafter referred to as I), which discussed Bose particle systems. Since there is particular interest in spin systems, and since the arguments and numerical analysis will differ somewhat, the magnetic case will be presented in a self-contained fashion (although some allusion will be made to analogous procedures used in the Bose case). The reader should consult the Introduction and Sec. II of I for a general description of notation and strategy² (to be summarized briefly below), but those interested solely in spin systems can omit the discussion of second quantization in I [Eqs. (I 2.3)–(I 2.15)].

We consider an anisotropic Heisenberg ferromag-

net of $\mathfrak{N}(\Omega)$ localized spins $\vec{S}(\vec{r})$ occupying the sites \vec{r} of a regular lattice contained in a three-dimensional domain Ω . We take the Hamiltonian to be [(I 2.1)]

$$\mathcal{H}_\Omega = -\frac{1}{2} \sum_{\vec{r}} \sum_{\vec{r}'} J_\alpha(\vec{r}, \vec{r}') S^\alpha(\vec{r}) S^\alpha(\vec{r}') + \sum_{\vec{r}} \vec{h}(\vec{r}) \cdot \vec{S}(\vec{r}), \quad (1.1)$$

where $\vec{h}(\vec{r})$ is the external field in energy units ($\vec{h} = \frac{1}{2} g \mu_B \vec{H}$), while $J_\alpha(\vec{r}, \vec{r}')$ is the exchange coupling. We will allow $J_\alpha(\vec{r}, \vec{r}')$ to be regular or to vary randomly throughout the lattice, subject only to the condition of "planar" isotropy, i. e.,

$$J_x(\vec{r}, \vec{r}') = J_y(\vec{r}, \vec{r}') = J_z(\vec{r}, \vec{r}') = J(\vec{r}', \vec{r}) \quad \text{for } \vec{r}, \vec{r}' \in \Omega. \quad (1.2)$$

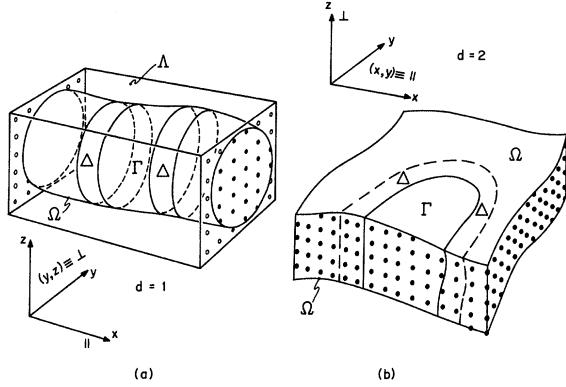

FIG. 1. Sectioned domain Ω showing a "slice" subdomain Γ and surrounding corridor Δ . A coordinate system is shown indicating the decomposition of a vector into parallel (\parallel) and perpendicular (\perp) components. (a) One-dimensional case showing, in addition, the enclosing "box" Λ and the lattice structure. (b) Two-dimensional case; enclosing box Λ not shown.

No restrictions will be made on $J_z(\vec{r}, \vec{r}')$. The correlation function is taken to be [(I 2. 18)]

$$\sigma_\Omega^\alpha(\vec{r}, \vec{r}') = \langle S^\alpha(\vec{r}) S^\alpha(\vec{r}') \rangle_\Omega, \quad (1.3)$$

or [(I 2. 19)]

$$\sigma_\Omega(\vec{r}, \vec{r}') = \langle S^+(\vec{r}) S^-(\vec{r}') \rangle_\Omega, \quad S^\pm = S^x \pm i S^y. \quad (1.4)$$

A "slice" subdomain $\Gamma \subset \Omega$ is chosen [see Fig. 1, and the discussion after (I 3. 1)], and we shall concentrate attention on the order parameter $\Psi_\Omega\{f | \Gamma\}$ defined by [(I 2. 23)]:

$$\begin{aligned} [\mathfrak{N}(\Gamma) \Psi_\Omega\{f | \Gamma\}]^2 &= \mathfrak{N}(\Gamma) m_\Omega\{f | \Gamma\} = \langle \left| \sum_{\vec{r} \in \Gamma} f(\vec{r}) S^+(\vec{r}) \right|^2 \rangle \\ &= \sum_{\vec{r} \in \Gamma} \sum_{\vec{r}' \in \Gamma} f^*(\vec{r}') f(\vec{r}) \sigma_\Omega(\vec{r}, \vec{r}'), \end{aligned} \quad (1.5)$$

subject to [(I 2. 22)]

$$\begin{aligned} |f(\vec{r})| &= 1 \quad \text{for } \vec{r} \in \Gamma \\ &= 0 \quad \text{otherwise.} \end{aligned} \quad (1.6)$$

Note that when $f(\vec{r}) = 1$ in Γ , the order parameter is simply proportional to the square of the total magnetization in Γ ; similarly, if we choose $f(\vec{r}) = e^{i\vec{k}_0 \cdot \vec{r}}$, where \vec{k}_0 is fixed, the order parameter is the square of the corresponding total "antiferromagnetic" magnetization.

If, in the thermodynamic limit, Ω may be contained between two parallel planes of a fixed, finite separation, we say the dimensionality is *restricted* to $d=2$.³ Similarly, if Ω can be contained within a cylinder of fixed, finite rectangular cross section, the dimensionality is said to be *restricted* to $d=1$.³ We refer to the infinite domain enclosing Ω as the

"box" Λ .

Two questions pertaining to magnetic systems in restricted dimensionality were posed in the Introduction of I (see also Ref. 2). In the first place, one would like to know how the static order-order-correlation function decays for large spatial separations of the arguments. Secondly, one would like to prove the absence of spontaneous ordering⁴ without the introduction of a symmetry-breaking field. We have found that Bogoliubov's inequality⁵

$$\frac{1}{2} \langle \{A, A^\dagger\} \rangle \geq k_B T \langle |C, A|^2 \rangle / \langle [C, \mathfrak{H}_\Omega], C^\dagger \rangle, \quad (1.7)$$

which is valid for any Hermitian Hamiltonian as long as the traces exist, can be manipulated to provide answers to these questions.

For spin systems described by (1. 1) and (1. 2) [with $h_x(\vec{r}) = h_y(\vec{r}) = 0$], in which $J(\vec{r}, \vec{r}')$ does not decay to zero too slowly, we will establish the bounds

$$\begin{aligned} \Psi_\Omega\{f | \Gamma\} &\leq \Phi_1 / [T \mathfrak{N}(\Gamma)]^{1/4} \quad \text{for } d=1 \\ &\leq \Phi_2 / \{T \ln[\mathfrak{N}(\Gamma)/\mathfrak{N}_0]\}^{1/2} \quad \text{for } d=2 \end{aligned} \quad (1.8)$$

as $\mathfrak{N}(\Gamma)$, the number of spins in the subdomain Γ , goes to infinity. The coefficients Φ_1 , Φ_2 , and \mathfrak{N}_0 can be derived from the explicit formulas developed below [see (5. 6)–(5. 8), and (5. 19) and following]; they are slowly varying functions of intensive parameters, and are independent of T except that at high temperatures Φ_1 falls as $1/T^{1/4}$.

These bounds remain (uniformly) valid if the thermodynamic limit $\mathfrak{N}(\Omega) \rightarrow \infty$ is taken on the left-hand side, and also if transverse fields $h_x(\vec{r})$ and $h_y(\vec{r})$ are imposed *outside* the subdomain Γ . The decrease of the limiting order $\Psi_\infty\{f | \Gamma\}$ to zero as $\mathfrak{N}(\Gamma) \rightarrow \infty$ implies the absence of long-range order in the infinite system. The absence of spontaneous total order is proved by setting $\Gamma = \Omega$ and $f = 1$ before taking the thermodynamic limit. The rate of decrease of $\Psi_\infty\{f | \Gamma\}$ with $\mathfrak{N}(\Gamma)$ indicates the rate of decay of the pointwise correlation function $\sigma_\infty(\vec{r}, \vec{r}')$. Roughly speaking, (1. 8) means that $\sigma_\infty(\vec{r}, \vec{r}')$ must decrease at least as fast as $1/|\vec{r} - \vec{r}'|^{1/2}$ for $d=1$, and as $1/\ln|\vec{r} - \vec{r}'|$ for $d=2$; in certain circumstances bounds on $\sigma_\infty(\vec{r}, \vec{r}')$ of this form can indeed be established (see Sec. VI). It may be noted, however, that the rates of decrease are not fast enough to ensure that $\sigma_\infty(\vec{0}, \vec{r})$ is integrable. Consequently, an infinite susceptibility or "weak long-range order"⁶ has not been ruled out.

The form of the $\mathfrak{N}(\Gamma)$ dependence of the bounds (1. 8) remains valid whenever the appropriately averaged exchange interactions $J_\Gamma(\vec{R})$ ($\vec{R} = \vec{r} - \vec{r}'$; see Sec. III) have a finite second spatial moment. More generally, however, the absence of long-range order will be demonstrated under circumstances where the second moment diverges or, when $d=1$, where even the first moment diverges. In these cases the pointwise correlation functions must still

decay to zero but the bounds will decrease more slowly than described above.

The outline of this paper is as follows: In Sec. II the basic inequality [analogous to (I 3.43)] is obtained for the special case of nearest-neighbor interactions; this inequality is extended to general interactions in Sec. III (but less care is exercised in obtaining best possible results). The inequalities for both nearest-neighbor and long-range interactions are analyzed in Sec. IV, while more detailed numerical bounds, principally for the nearest-neighbor case, are presented in Sec. V. In Sec. VI we conclude by showing how bounds on the pointwise correlation functions may be found.

II. BASIC INEQUALITY FOR SPIN SYSTEMS

In this and the following sections we discuss spin systems on the basis of the Heisenberg-Ising Hamiltonian (1.1) subject only to the axial symmetry condition

$$J_x(\vec{r}, \vec{r}') = J_y(\vec{r}, \vec{r}') \equiv J(\vec{r}, \vec{r}') = J(\vec{r}', \vec{r}) . \quad (2.1)$$

Note that $J(\vec{r}, \vec{r}')$ may be of either sign and no restrictions are placed on $J_x(\vec{r}, \vec{r}')$.

In the interests of clarity and simplicity we will suppose the lattice on which the spins are located is of simple cubic structure with spacing a . In addition, we will assume that the lattice domain Ω containing $\mathfrak{N}(\Omega)$ spins can itself be contained in a "box" domain Λ , which, in the case $d=2$, contains *exactly* \mathfrak{N}_z layers of an infinite square lattice stacked to form a simple cubic lattice of nominal thickness $L_z \equiv \mathfrak{N}_z a$. Similarly, in the one-dimensional case we suppose Λ contains exactly $\mathfrak{N}_y, \mathfrak{N}_z$ infinite linear chains arranged in rectilinear array to form a simple cubic lattice of nominal cross section $L_y \times L_z \equiv \mathfrak{N}_y a \times \mathfrak{N}_z a$. The case in which the boundaries of Λ are not oriented parallel to the primitive lattice vectors and in which the lattice is not simple cubic involve no new difficulties of principle but, clearly, lead to some geometrical complications. The meaning of a "slice" subdomain Γ containing $\mathfrak{N}(\Gamma)$ spins remains as illustrated in Fig. 1.

To apply Bogoliubov's inequality (1.7), we choose

$$C = \sum_{\vec{r}} S^z(\vec{r}) g(\vec{r}), \quad g(\vec{r}) = u(\vec{r}) e^{i\vec{k} \cdot \vec{r}} \quad (2.2)$$

in which \vec{k} is arbitrary. We will first present a simple form of the argument which does not utilize a "corridor" – that is, a region surrounding the subdomain Γ in which $u(\vec{r})$ drops slowly to zero (see Sec. III of I). The somewhat more elaborate analysis allowing for a corridor will be presented for nearest-neighbor interactions following Eq. (2.51); the resulting, numerically better bounds will be discussed in Sec. V. For the present, therefore, we consider

$$u(\vec{r}) = 1 \quad \text{for } \vec{r} \in \Gamma$$

$$= 0 \quad \text{otherwise} . \quad (2.3)$$

With this choice we find

$$\begin{aligned} \langle [C, \mathfrak{H}_\Omega], C^\dagger \rangle &= \frac{1}{2} \sum_{\vec{r}} \sum_{\vec{r}'} J(\vec{r}, \vec{r}') |g(\vec{r}) - g(\vec{r}')|^2 \\ &\quad \times [\langle S^x(\vec{r}) S^x(\vec{r}') \rangle + \langle S^y(\vec{r}) S^y(\vec{r}') \rangle] \\ &\quad + \sum_{\vec{r}} |g(\vec{r})|^2 [h_x(\vec{r}) \langle S^x(\vec{r}) \rangle \\ &\quad + h_y(\vec{r}) \langle S^y(\vec{r}) \rangle] , \quad (2.4) \end{aligned}$$

where $\langle \cdot \rangle$ denotes the statistical expectation value calculated with \mathfrak{H}_Ω . Now use of Schwarz's inequality yields

$$\begin{aligned} \langle S_1^x S_2^x \rangle + \langle S_1^y S_2^y \rangle &\leq \| (S_1^x \vec{e}_x + S_1^y \vec{e}_y) \cdot (S_2^x \vec{e}_x + S_2^y \vec{e}_y) \| \\ &\leq \| (S_1^x)^2 + (S_1^y)^2 \|^{1/2} \| (S_2^x)^2 + (S_2^y)^2 \|^{1/2} \\ &\leq \| (S^x)^2 + (S^y)^2 \| , \quad (2.5) \end{aligned}$$

where \vec{e}_x and \vec{e}_y are orthogonal unit vectors and $\| \cdot \|$ denotes the spectral norm of the operator, i. e., essentially the modulus of its largest eigenvalue. Then by using a representation in which \vec{S}^2 and S^z are diagonal we see that

$$\begin{aligned} \| (S^x)^2 + (S^y)^2 \| &= \max_{S^z} \{ S(S+1) - (S^z)^2 \} \\ &= \vec{S}^2 = S(S+1) \quad \text{for } S \text{ integral} \\ &= S(S+1) - \frac{1}{4} \quad \text{for } S \text{ half} \\ &\quad \text{odd integral.} \quad (2.6) \end{aligned}$$

Combining these results in (2.4) yields

$$\begin{aligned} \langle [C, \mathfrak{H}_\Omega], C^\dagger \rangle &\leq \frac{1}{2} \vec{S}^2 \sum_{\vec{r}} \sum_{\vec{r}'} |J(\vec{r}, \vec{r}')| |g(\vec{r}) - g(\vec{r}')|^2 \\ &\quad + \sum_{\vec{r}} |g(\vec{r})|^2 [h_x(\vec{r}) \langle S^x(\vec{r}) \rangle + h_y(\vec{r}) \langle S^y(\vec{r}) \rangle] . \quad (2.7) \end{aligned}$$

Next we choose

$$A = \sum_{\vec{r}} \sum_{\vec{R}} f^*(\vec{r}) e^{-i\vec{k} \cdot \vec{r}} f(\vec{R}) S^+(\vec{r}) S^-(\vec{R}) , \quad (2.8)$$

where $f(\vec{r})$ is arbitrary apart from the restriction

$$\begin{aligned} |f(\vec{r})| &= 1 \quad \text{for } \vec{r} \in \Gamma \\ &= 0 \quad \text{otherwise} . \quad (2.9) \end{aligned}$$

Then with [see (1.5)]

$$\begin{aligned} n\{f\} &= n_\Omega \{f | \Gamma\} \\ &= [\mathfrak{N}(\Gamma)]^{-1} \sum_{\vec{r} \in \Gamma} \sum_{\vec{r}' \in \Gamma} f^*(\vec{r}') f(\vec{r}) \langle S^+(\vec{r}') S^-(\vec{r}) \rangle \quad (2.10) \end{aligned}$$

[which is in accord with the definitions (I 2.19) and (I 2.23)], we obtain for the Bogoliubov numerator

$$\langle [C, A] \rangle^2 = [\mathfrak{N}(\Gamma) (n\{f\} - n\{f e^{i\vec{k} \cdot \vec{r}}\})]^2 . \quad (2.11)$$

Now we introduce specific wave vectors appropriate to the lattice contained in the box Λ , namely,

$$\vec{k} = (\vec{k}_{\parallel}, \vec{k}_{\perp}) = (k_{\parallel}; 2\pi l_y/L_y, 2\pi l_z/L_z), \quad d=1$$

$$= (k_{\parallel,x}, k_{\parallel,y}; 2\pi l_z/L_z), \quad d=2, \quad (2.12)$$

where \vec{k} is restricted to the first Brillouin zone of the simple cubic lattice, i. e., \vec{k}_{\parallel} is a continuous vector with

$$|k_{\parallel,\alpha}| \leq \pi/a, \quad \alpha = x, y, \quad (2.13)$$

and

$$l_{\alpha} = 0, 1, 2, \dots, \mathfrak{N}_{\alpha} - 1, \quad \alpha = y, z. \quad (2.14)$$

Then, defining the number of sites in a cross section of Λ by

$$\mathfrak{N}_d = \mathfrak{N}_y \mathfrak{N}_z, \quad d=1$$

$$= \mathfrak{N}_z, \quad d=2, \quad (2.15)$$

we have, for all sites \vec{r} and \vec{r}' in Λ ,

$$\mathfrak{N}_d^{-1} \sum_{\vec{k}_{\perp}} (a/2\pi)^d \int d\vec{k}_{\parallel} e^{i\vec{k} \cdot (\vec{r} - \vec{r}')} = \delta_{\vec{r}, \vec{r}'}, \quad (2.16)$$

where $\delta_{\vec{r}, \vec{r}'}$ is the Kronecker δ function.

We will integrate the whole Bogoliubov inequality (1.7) subject to

$$\vec{k}_{\perp} \equiv 0 \text{ and } \kappa \leq |\vec{k}_{\parallel}| \leq \kappa^{\dagger} \leq \pi/a. \quad (2.17)$$

Nonpositive terms on the right-hand side and non-negative terms on the left-hand side of the inequality may be integrated over all \vec{k}_{\parallel} and further summed over all \vec{k}_{\perp} , since these operations can only strengthen the inequality. Now the left-hand side $L(\vec{k}_{\parallel}, \vec{k}_{\perp})$ is intrinsically positive, and so on extending the sum we obtain

$$L = (a/2\pi)^d \int_{\kappa} d\vec{k}_{\parallel} L(\vec{k}_{\parallel}, \vec{0})$$

$$\leq \frac{1}{2} \mathfrak{N}_d \sum_{\vec{r} \in \Gamma} \sum_{\vec{R} \in \Gamma} \sum_{\vec{R}' \in \Gamma} f^*(\vec{R}') f(\vec{R}) [\langle S^+(\vec{r}') S^-(\vec{R}) S^+(\vec{R}') S^-(\vec{r}) \rangle$$

$$+ \langle S^+(\vec{R}') S^-(\vec{r}') S^+(\vec{r}) S^-(\vec{R}) \rangle], \quad (2.18)$$

where the subscript κ denotes integration subject to (2.17). By use of the spin commutation relations this reduces to the sum of the two terms

$$L_1 = \mathfrak{N}_d \sum_{\vec{r} \in \Gamma} \sum_{\vec{R} \in \Gamma} \sum_{\vec{R}' \in \Gamma} f^*(\vec{R}') f(\vec{R})$$

$$\times \langle S^+(\vec{R}') \{ [S^x(\vec{r})]^2 + [S^y(\vec{r})]^2 \} S^-(\vec{R}) \rangle, \quad (2.19)$$

$$L_2 = -\mathfrak{N}_d \sum_{\vec{r} \in \Gamma} \sum_{\vec{R} \in \Gamma} \langle S^+(\vec{r}) S_x(\vec{R}) S^-(\vec{r}) \rangle. \quad (2.20)$$

Both these terms are of the form

$$\langle X^{\dagger} Y X \rangle \leq \|Y\| \langle X^{\dagger} X \rangle, \quad (2.21)$$

where the inequality is easily proved, for example, by expanding in terms of the eigenvectors of Y .

The first term L_1 may thus be bounded by using (2.5) and the second L_2 by noting that $\| -S^{\alpha} \| = S$. This finally yields the inequality

$$L \leq \tilde{S}^2 \mathfrak{N}_d [\mathfrak{N}(\Gamma)]^2 n \{ f \} + \mathfrak{N}_d S \mathfrak{N}(\Gamma) \sum_{\vec{r} \in \Gamma} [\langle S^{\alpha}(\vec{r}) \rangle + \tilde{S}^2]$$

$$\leq \mathfrak{N}_d [\mathfrak{N}(\Gamma)]^2 [\tilde{S}^2 n \{ f \} + S(\tilde{S}^2 + S)], \quad (2.22)$$

where we have used the identity and inequalities

$$\langle S_1^{\dagger} S_1 \rangle \equiv \langle S(S+1) - (S_1^{\alpha})^2 + S_1^{\alpha} \rangle$$

$$\leq \tilde{S}^2 + \langle S_1^{\alpha} \rangle \leq \tilde{S}^2 + S. \quad (2.23)$$

Since there is particular interest in results for nearest-neighbor models, and since the arguments for long-range interactions are somewhat more elaborate, we analyze the right-hand side of (1.7) first for *nearest-neighbor interactions* and, as mentioned, without the introduction of a corridor. Note that the analysis of the left-hand side and of the numerator of the Bogoliubov inequality (1.7) [see Eqs. (2.8)–(2.23)] is quite independent of the choice of $u(\vec{r})$ outside Γ , and hence of the presence of a corridor. In this case we have

$$J(\vec{r}, \vec{r}') = J(\vec{r}; \vec{\delta}) \quad \text{if } \vec{r} \text{ and } \vec{r}' = \vec{r} + \vec{\delta} \text{ are}$$

$$\quad \quad \quad \text{nearest neighbors}$$

$$= 0 \quad \text{otherwise.} \quad (2.24)$$

Now to simplify the first term in the bound (2.7) for the double commutator, we note that

$$|g(\vec{r}) - g(\vec{r}')|^2 = 0, \quad \text{neither } \vec{r} \text{ nor } \vec{r}' \text{ in } \Gamma$$

$$= |e^{i\vec{k} \cdot (\vec{r} - \vec{r}')} - 1|^2, \quad \vec{r} \text{ and } \vec{r}' \text{ both in } \Gamma$$

$$= 1, \quad \text{only one of } \vec{r} \text{ or } \vec{r}' \text{ in } \Gamma. \quad (2.25)$$

Furthermore, we have generally

$$|e^{i\vec{k} \cdot \vec{\delta}} - 1|^2 = 4 \sin^2(\frac{1}{2} \vec{k} \cdot \vec{\delta})$$

$$= 2[1 - \cos(\vec{k} \cdot \vec{\delta})] \leq (\vec{k} \cdot \vec{\delta})^2. \quad (2.26)$$

If $\vec{\delta}$ is a nearest-neighbor vector, i. e., $\vec{\delta} = \vec{\delta}_{\alpha}$ = $\pm a \vec{e}_{\alpha}$ ($\alpha = x, y, z$), then $\vec{k} \cdot \vec{\delta} = k_{\alpha} a$. In order to utilize (2.25) we split the double sum over \vec{r} and \vec{r}' in (2.7) into three pieces:

(i) an identically zero contribution from terms with neither \vec{r} nor \vec{r}' in Γ ;

(ii) a "bulk" contribution $U_1(\vec{k})$ from terms with both \vec{r} and \vec{r}' in Γ ;

(iii) a "surface" contribution U_2 independent of \vec{k} , from terms with only one of \vec{r} or \vec{r}' in Γ .

Now the sum defining U_1 may be decomposed into sums over nearest-neighbor bonds parallel to the x , y , and z axes. We can then define corresponding *mean nearest-neighbor coupling strengths* by

$$J_{\Gamma}^{\alpha} = \frac{1}{2} [\mathfrak{N}(\Gamma)]^{-1} \sum_{\vec{r} \in \Gamma} \sum_{\vec{\delta}_{\alpha}} |J(\vec{r}; \vec{\delta}_{\alpha})|, \quad (2.27)$$

where $\vec{\delta}_{\alpha} = \pm a \vec{e}_{\alpha}$ ($\alpha = x, y$, or z). Then if the *overall mean nearest-neighbor coupling*, which will provide our basic measure of the interaction strength,

is defined by

$$J_\Gamma = \max_\alpha \{J_\Gamma^\alpha\}, \quad (2.28)$$

we find, using (2.26), that

$$U_1(\vec{k}) < \tilde{S}^2 \mathfrak{N}(\Gamma) J_\Gamma k^2 a^2. \quad (2.29)$$

It is clear from (2.27) and (2.28) that in a uniform lattice one simply has $J_\Gamma = |J|$. If, in a nonuniform lattice, one has a uniform bound $|J(\vec{r}, \vec{r}')| \leq J_0$ for \vec{r}, \vec{r}' in Γ , one may replace J_Γ by J_0 in (2.29) and all subsequent formulas. We may also remark that, since ultimately we will only need (2.29) in the case where $\vec{k}_\perp = 0$ [in accord with (2.17)], we may restrict α in (2.28) to $\alpha = x$ for $d = 1$ and $\alpha = x$ or y for $d = 2$.

To simplify the surface term U_2 we define the number of nearest-neighbor bonds crossing the boundary or "surface" of Γ by

$$\mathfrak{N}_\Delta = \sum_{\vec{r} \in \Gamma} \sum_{\vec{r} + \vec{\delta} \in \Omega - \Gamma} 1, \quad (2.30)$$

and the corresponding mean coupling strength across the surface by

$$J_\Delta = (\mathfrak{N}_\Delta)^{-1} \sum_{\vec{r} \in \Gamma} \sum_{\vec{r} + \vec{\delta} \in \Omega - \Gamma} |J(\vec{r}; \vec{\delta})|. \quad (2.31)$$

The surface contribution to the double commutator is thus

$$U_2 = \tilde{S}^2 \mathfrak{N}_\Delta J_\Delta. \quad (2.32)$$

Again, in a uniform lattice we have $J_\Delta = |J|$, while a bound $|J(\vec{r}, \vec{r}')| \leq J_1$ on the "surface" interactions enables one to replace J_Δ by J_1 in all the following formulas. On combining terms, the relation (2.7) now yields

$$\langle \langle [C, \mathfrak{H}_\Omega], C^\dagger \rangle \rangle \leq \tilde{S}^2 J_\Gamma \mathfrak{N}(\Gamma) a^2 [k^2 + \lambda], \quad (2.33)$$

where

$$a^2 \lambda = (J_\Delta / J_\Gamma) [\mathfrak{N}_\Delta / \mathfrak{N}(\Gamma)] + (1 / J_\Gamma \tilde{S}^2) H\{\vec{h}_\perp; \Gamma\}, \quad (2.34)$$

in which

$$H\{\vec{h}_\perp; \Xi\} \equiv [\mathfrak{N}(\Xi)]^{-1} \sum_{\vec{r} \in \Xi} [h_x(\vec{r}) \langle S^x(\vec{r}) \rangle + h_y(\vec{r}) \langle S^y(\vec{r}) \rangle] \quad (2.35)$$

as in (I 3.11).

Note that if $\Gamma = \Omega$, the first term in (2.34) vanishes identically since $\mathfrak{N}_\Delta = 0$. Furthermore, if the transverse magnetic fields vanish, we have

$$\lambda \equiv 0 \text{ for } \Gamma = \Omega, \quad h_x(\vec{r}) = h_y(\vec{r}) = 0. \quad (2.36)$$

More generally, note that the first term will vanish as $\mathfrak{N}(\Gamma) \rightarrow \infty$, as it is essentially a surface-to-volume ratio. However, unless the transverse fields become uniformly small in the subdomain Γ , the second term in (2.34) can remain finite. In what follows, we shall assume, unless explicitly stated otherwise, that the transverse fields in Γ , if present, are

reduced to zero rapidly enough to ensure that

$$\lambda \rightarrow 0 \text{ as } \mathfrak{N}(\Gamma) \rightarrow \infty. \quad (2.37)$$

By (2.11) and (2.33), the right-hand side of the Bogoliubov inequality (1.7) thus satisfies

$$R(\vec{k}_\parallel, \vec{k}_\perp) \geq \frac{\mathfrak{N}(\Gamma) k_B T}{\tilde{S}^2 J_\Gamma a^2} \frac{[n\{f\} - n\{f e^{i\vec{k} \cdot \vec{r}}\}]^2}{k^2 + \lambda}. \quad (2.38)$$

Integrating this inequality subject to (2.17), we find

$$R = (a/2\pi)^d \int_\kappa d\vec{k}_\parallel R(\vec{k}_\parallel, \vec{0}) \geq \frac{k_B T \mathfrak{N}(\Gamma)}{\tilde{S}^2 J_\Gamma a^2} [n^2\{f\} a^d I(\kappa, \lambda) - 2n\{f\} J(\kappa, \lambda)], \quad (2.39)$$

where the positive term involving $n^2\{f e^{i\vec{k} \cdot \vec{r}}\}$ has been dropped. The integral $I(\kappa, \lambda)$ is defined by

$$I(\kappa, \lambda) = (2\pi)^{-d} \int_\kappa d\vec{k}_\parallel / (k_\parallel^2 + \lambda). \quad (2.40)$$

Its explicit value and its behavior in various limits are given by formulas (I 3.22)–(I 3.24). (These forms will be introduced when needed.) The second integral in (2.39) is

$$J(\kappa, \lambda) = (a/2\pi)^d \int_\kappa d\vec{k}_\parallel n\{f e^{i\vec{k} \cdot \vec{r}}\} / (k_\parallel^2 + \lambda), \quad (2.41)$$

which may be bounded (as in the Bose case) by (i) noting that $n\{\cdot\}$ is non-negative; (ii) extending the integral to all \vec{k}_\parallel after removal of a factor $(\kappa^2 + \lambda)^{-1}$; and (iii) summing on all \vec{k}_\perp and using (2.10), (2.16), and (2.23). This yields

$$\begin{aligned} J(\kappa, \lambda) &\leq (\kappa^2 + \lambda)^{-1} \sum_{\vec{k}_\perp} (a/2\pi)^d \int_\kappa d\vec{k}_\parallel n\{f e^{i\vec{k} \cdot \vec{r}}\} \\ &\leq \mathfrak{N}_\Delta (\kappa^2 + \lambda)^{-1} [\mathfrak{N}(\Gamma)]^{-1} \sum_{\vec{r} \in \Gamma} \langle S^+(\vec{r}) S^-(\vec{r}) \rangle \\ &\leq \mathfrak{N}_\Delta (\kappa^2 + \lambda)^{-1} [\tilde{S}^2 + M_\Omega^s(\Gamma)], \end{aligned} \quad (2.42)$$

where we have introduced the mean magnetization in Γ defined by

$$M_\Omega^s(\Gamma) = [\mathfrak{N}(\Gamma)]^{-1} \sum_{\vec{r} \in \Gamma} \langle S^s(\vec{r}) \rangle_\Omega. \quad (2.43)$$

On using (2.42) to strengthen (2.39) and combining with the first part of (2.22), the integrated form of Bogoliubov's inequality for a spin system becomes

$$\begin{aligned} \mathfrak{N}_\Delta [\mathfrak{N}(\Gamma)] [\tilde{S}^2 (n\{f\} + S) + S M_\Omega^s(\Gamma)] &\geq \frac{k_B T}{\tilde{S}^2 J_\Gamma a^2} (n^2\{f\} a^d I(\kappa, \lambda) \\ &\quad - 2n\{f\} \mathfrak{N}_\Delta (\kappa^2 + \lambda)^{-1} [\tilde{S}^2 + M_\Omega^s(\Gamma)]) \end{aligned} \quad (2.44)$$

Collecting terms and transposing yields

$$\Psi^2 \left[1 + \frac{q_1}{\mathfrak{N}(\Gamma) (\kappa^2 + \lambda)} \right] + \frac{q_2}{\mathfrak{N}(\Gamma)} \geq q_0 I(\kappa, \lambda) \Psi^4, \quad (2.45)$$

where

$$q_0 = (k_B T / J_\Gamma) (a^{d-2} / \tilde{S}^4 \mathfrak{N}_\Delta), \quad (2.46)$$

$$q_1 = (k_B T / J_T) (2/\bar{S}^4 a) [\bar{S}^2 + M_\Omega^*(\Gamma)] , \quad (2.47)$$

$$q_2 = (S/\bar{S}^2) [\bar{S}^2 + M_\Omega^*(\Gamma)] , \quad (2.48)$$

and where

$$\begin{aligned} \Psi^2 &= \Psi_\Omega^2 \{f | \Gamma\} = n \{f\} / \mathfrak{N}(\Gamma) \\ &= \langle |\mathfrak{N}(\Gamma)^{-1} \sum_{\vec{r} \in \Gamma} f(\vec{r}) S^-(\vec{r})|^2 \rangle_\Omega , \end{aligned} \quad (2.49)$$

as in (1.5). The inequality can be linearized for $\xi = \Psi^2$, as in the Bose case, by noting that if ξ_1 is the positive root of the corresponding equality, then $\Psi^2 \leq \xi_1$. If, in addition, we simplify the root ξ_1 by using $(1 + \xi)^{1/2} \leq 1 + \frac{1}{2}\xi$, we obtain

$$\Psi_\Omega^2 \{f | \Gamma\} \leq \frac{q_1(X)}{q_0 J(\kappa, \lambda)} + \frac{q_2}{q_1(X) \mathfrak{N}(\Gamma)} , \quad (2.50)$$

where

$$q_1(X) = 1 + q_1/X, \quad X = \mathfrak{N}(\Gamma)(\kappa^2 + \lambda) \quad (2.51)$$

which may be compared with the Bose result (I3.44).

We now show how the above analysis must be modified if one introduces a corridor surrounding Γ in which $u(\vec{r})$ decreases "smoothly" to zero [in contrast to the choice (2.3)]. The final result (2.50) is again obtained but with somewhat different expressions for the parameter λ and for the constants q_0 , q_1 , and q_2 . The dependence on $\mathfrak{N}(\Gamma)$ of the order is not affected by the introduction of the corridor, but the change in the definition of λ will lead to an amplitude with a more favorable temperature dependence, particularly in the $d=1$ case; the relative gains are discussed in Sec. V. We remark once again that the introduction of the corridor affects only the estimation of the double commutator in (1.7).

The corridor Δ , containing $\mathfrak{N}(\Delta)$ sites, surrounds the subdomain Γ and is defined simply as follows.⁷ Let Δ_0 be the set of sites on the boundary of Γ (boundary sites are in Γ but have neighbors in Ω not in Γ). Let Δ_1 be the set of sites which are nearest neighbors of the sites in Δ_0 but are not in Γ . Similarly, let Δ_2 be the set of sites which are nearest neighbors of sites in Δ_1 , but are not in Δ_0 or Δ_1 . Continue similarly for ν "shells" ending with the set Δ_ν . The case of no corridor corresponds to $\nu=1$ and has been treated above. Now define the corridor Δ by

$$\Delta = \Delta_1 \cup \Delta_2 \cup \Delta_3 \cdots \cup \Delta_{\nu-1}, \quad \nu > 1 .$$

Furthermore, we make a new choice for the function $u(\vec{r})$ introduced in (2.2):

$$\begin{aligned} \text{(i)} \quad u(\vec{r}) &= 1 & \text{for } \vec{r} \in \Gamma \\ \text{(ii)} \quad &= 0 & \text{for } \vec{r} \notin \Gamma \cup \Delta \\ \text{(iii)} \quad &= 1 - (p/\nu) & \text{for } \vec{r} \in \Delta_p \quad (p=0, 1, \dots, \nu) . \end{aligned} \quad (2.52)$$

By construction we then have the property [see after (I3.33)]

$$\Delta u(\vec{r}; \vec{\delta}) = |u(\vec{r}) - u(\vec{r} + \vec{\delta})| \leq \nu^{-1} \text{ for } \vec{r} \in \Omega , \quad (2.53)$$

which will enable us to bound the double commutator in (1.7).

Now Eq. (2.7) is still valid, and it will be evaluated in a fashion similar to the method used in deriving (2.26)–(2.32). (Nearest-neighbor interactions only are considered.) Firstly, the double sum in (2.7) is divided into three contributions: (i) an identically zero contribution from terms with neither \vec{r} nor \vec{r}' in $\Gamma \cup \Delta$; (ii) a "bulk" contribution from terms with both \vec{r} and \vec{r}' in Γ ; and (iii) a "surface" contribution from terms with either \vec{r} or \vec{r}' , or both, in Δ . By using (2.52), (2.53), and (2.26) we find, for $\vec{r}' = \vec{r} + \vec{\delta}$,

$$\begin{aligned} |g(\vec{r}) - g(\vec{r}')|^2 &= |u(\vec{r}) - u(\vec{r}') e^{i\vec{k} \cdot \vec{\delta}}|^2 \\ &= |u(\vec{r}) - u(\vec{r}') - u(\vec{r}') (e^{i\vec{k} \cdot \vec{\delta}} - 1)|^2 \\ &\leq |u(\vec{r}) - u(\vec{r}')|^2 + |u(\vec{r}')|^2 |e^{i\vec{k} \cdot \vec{\delta}} - 1|^2 \\ &\leq \Delta u^2(\vec{r}; \vec{\delta}) + (ka)^2 . \end{aligned} \quad (2.54)$$

The double sum thus yields an "extended" bulk contribution bounded by

$$U_1(\vec{k}) \leq \bar{S}^2 \mathfrak{N}(\Gamma \cup \Delta) J_{\Gamma \cup \Delta} (ka)^2 ,$$

where $J_{\Gamma \cup \Delta}$ is defined by (2.27) and (2.28) but with Γ replaced by $\Gamma \cup \Delta$. The appropriate generalization of the "surface number" \mathfrak{N}_Δ defined in (2.30) is (for $\nu \neq 1$)

$$\mathfrak{N}_\Delta = \frac{1}{2} \sum_{\vec{r}} \sum_{\vec{\delta}} 1; \quad (2.55)$$

$$\Delta_\mu(\vec{r}; \vec{\delta}) \neq 0$$

this is simply the number of nearest-neighbor bonds along which the function $u(\vec{r})$ changes. The generalized "surface exchange" may then be defined (for $\nu \neq 1$) by

$$J_\Delta = \mathfrak{N}_\Delta^{-1} \sum_{\vec{r}} \sum_{\vec{\delta}} 1. \quad (2.56)$$

$$\Delta_\mu(\vec{r}; \vec{\delta}) \neq 0$$

In the no-corridor case $\nu=1$, these definitions should be replaced by (2.30) and (2.31). The original treatment of the magnetic field terms in (2.7) needs no alteration, so that the double commutator is finally bounded by

$$\langle [C, \mathfrak{H}_\Omega, C^\dagger] \rangle \leq \bar{S}^2 J_{\Gamma \cup \Delta} \mathfrak{N}(\Gamma \cup \Delta) a^2 [k^2 + \lambda] , \quad (2.57)$$

where

$$a^2 \lambda = \nu^{-2} \mu_1 [\mathfrak{N}_\Delta / \mathfrak{N}(\Gamma \cup \Delta)] + (1/J_{\Gamma \cup \Delta} \bar{S}^2) H\{\vec{h}_1; \Gamma \cup \Delta\} ,$$

with

$$\mu_1 = J_\Delta / J_{\Gamma \cup \Delta} . \quad (2.58)$$

The definition (2.35) for $H\{\cdot\}$ still applies but the generalized definitions (2.55) and (2.56) must be used for \mathfrak{N}_Δ and J_Δ in (2.58). We may note that in the special case $\nu=1$ (no corridor), the results (2.57) and (2.58) simply reduce to (2.33) and (2.34). When $\Gamma=\Omega$, we set $\mathfrak{N}_\Delta=\mathfrak{N}(\Delta)=0$ as before.

Since the structure of the new equations (2.57) and (2.58) is identical to that for the no-corridor case ($\nu=1$), it is easy to see that (2.51) again follows, but with new definitions for the constants, namely,

$$q_0 = (1-\gamma)(k_B T/J_{\Gamma\cup\Delta})(a^{d-2}/\bar{S}^4 \mathfrak{N}_d), \quad (2.59)$$

$$q_1 = (1-\gamma)(k_B T/J_{\Gamma\cup\Delta})(2/\bar{S}^4 a^2)[\bar{S}^2 + M_\Omega^s(\Gamma)], \quad (2.60)$$

$$q_2 = (S/\bar{S}^2)[\bar{S}^2 + M_\Omega^s(\Gamma)], \quad (2.61)$$

with

$$\gamma = \mathfrak{N}(\Delta)/\mathfrak{N}(\Gamma\cup\Delta). \quad (2.62)$$

We remark that in order to prove the absence of ordering, we must have $\lambda \rightarrow 0$ as $\mathfrak{N}(\Gamma) \rightarrow \infty$. Again, we will assume that the transverse field h_\perp becomes uniformly small in Γ , so that the second term in (2.58) does not remain finite. Note that γ is essentially a surface-to-volume ratio; it will be necessary that ν [and hence $\mathfrak{N}(\Delta)$] be chosen in such a way that the first term in (2.58) vanishes as $\mathfrak{N}(\Gamma)$ becomes large. This implies that the constants q_0 , q_1 , and q_2 approach limits as $\mathfrak{N}(\Gamma) \rightarrow \infty$. These are sufficient conditions for the absence of order to be proven.

III. LONG-RANGE INTERACTIONS

In this section we consider spin-spin interactions which are not restricted to nearest neighbors but, rather, may be of infinite range. Our aim is to rederive the basic inequality (2.50), established in Sec. II, in essentially the same form but with suitable modifications of the definitions of J_Γ , J_Δ , λ , and $I(\kappa, \lambda)$, etc. The reader uninterested in the technical details may glance at the final result, (3.34), and then proceed to Sec. IV, where the basic inequality is analyzed to yield the desired bounds on the order parameters and correlation functions.

We remark at the outset that one of our main interests is in the rate of decay of $J(\vec{r}, \vec{r}')$ as $|\vec{r} - \vec{r}'| \rightarrow \infty$, needed to ensure the absence of long-range order. Accordingly, we will be content in a number of places with less stringent estimates than obtained in the corresponding formulas for nearest-neighbor interactions. In particular, no corridor will be introduced. Furthermore, for convenience, we will consider only slice subdomains Γ that are bounded by planes parallel to the primitive lattice axes; specifically, we suppose

$$d=1: \Gamma = \{\vec{r}; \vec{r} \subset \Omega, \quad 0 < x \leq \mathfrak{N}_x a\}, \quad (3.1)$$

$$d=2: \Gamma = \{\vec{r}; \vec{r} \subset \Omega, \quad 0 < x \leq \mathfrak{N}_x a, \quad 0 < y \leq \mathfrak{N}_y a\},$$

where \mathfrak{N}_x and \mathfrak{N}_y are integers. (No confusion can arise with the dimensions of Λ .) To match the distinction between \vec{k}_\parallel and \vec{k}_\perp we also write

$$\vec{r} = (\vec{r}_\parallel, \vec{r}_\perp), \quad \text{with } \vec{r}_\parallel = x, \quad d=1 \\ = (x, y), \quad d=2. \quad (3.2)$$

In addition, it is convenient to define the local thickness or cross section of the system, that is, the number of sites in Ω with the same fixed \vec{r}_\parallel ; explicitly this is given by

$$\mathfrak{N}_d(\vec{r}_\parallel) = \sum_{\substack{\vec{r}_\perp \\ \vec{r}_\perp \subset \Omega}} 1 \leq \mathfrak{N}_d. \quad (3.3)$$

Then we may define the *projected* interactions

$$J^r(\vec{r}_\parallel; \vec{R}_\parallel) = [\mathfrak{N}_d(\vec{r}_\parallel)]^{-1} \sum_{\substack{\vec{r}_\perp, \vec{R}_\perp \\ \vec{r}_\perp, \vec{R}_\perp \subset \Omega}} |J(\vec{r}; \vec{R})|. \quad (3.4)$$

It follows from the restriction $\vec{k}_\perp = 0$, to be imposed later in the analysis [see (2.17)], that we need concern ourselves only with these projected interactions. We may note that (a) for a system with only constant neighbor interactions J , we have $J^r(\vec{r}_\parallel, \vec{R}_\parallel) = |J|$ when \vec{R}_\parallel is a nearest-neighbor vector but $J^r \equiv 0$ otherwise. In the case (b) of a nonuniform system in which there is, nonetheless, a *uniform bound*

$$J(\vec{r}, \vec{r} + \vec{R}) = J(\vec{r}; \vec{R}) \leq J_0(|\vec{R}|) \quad (\text{all } \vec{r}, \vec{R}), \quad (3.5)$$

such that $J_0(R)$ is monotonic nonincreasing as R increases, one may use $|\vec{R}_\parallel, \vec{R}_\perp| \geq |\vec{R}_\parallel|$ and (3.3) to show that

$$J^r(\vec{r}_\parallel; \vec{R}_\parallel) \leq \mathfrak{N}_d J_0(|\vec{R}_\parallel|). \quad (3.6)$$

Now, as in Sec. II, we split the double sum in (2.7) into three pieces: (i) the vanishing contribution from terms with neither \vec{r} nor \vec{r}' in Γ ; (ii) the "bulk" contribution $U_1(\vec{k})$ from terms with both \vec{r} and \vec{r}' in Γ ; and (iii) the "surface" contribution U_2 from terms with only one of \vec{r} or \vec{r}' in Γ . To bound $U_1(\vec{k})$ we extend the sum on \vec{r}' in (2.7) to the whole lattice in Ω and use the second part of (2.26), which yields

$$U_1(\vec{k}) \leq \bar{S}^2 \sum_{\substack{\vec{r} \in \Gamma \\ \vec{r}' \in \Omega}} \sum_{\vec{R}} J(\vec{r}; \vec{R}) [1 - \cos(\vec{k} \cdot \vec{R})]. \quad (3.7)$$

If we restrict ourselves to $\vec{k} = (\vec{k}_\parallel, \vec{0})$, we may use the definition (3.4), and thence obtain

$$U_1(\vec{k}_\parallel, \vec{0}) \leq \bar{S}^2 \mathfrak{N}(\Gamma) \sum_{\vec{R}_\parallel} J_\Gamma(\vec{R}_\parallel) [1 - \cos(\vec{k}_\parallel \cdot \vec{R}_\parallel)], \quad (3.8)$$

where the *mean projected coupling energy* is defined by

$$J_\Gamma(\vec{R}_\parallel) = [\mathfrak{N}(\Gamma)]^{-1} \sum_{\vec{r}_\parallel \in \Gamma} \mathfrak{N}_d(\vec{r}_\parallel) J^r(\vec{r}_\parallel; \vec{R}_\parallel) \\ = [\mathfrak{N}(\Gamma)]^{-1} \sum_{\substack{\vec{r} \in \Gamma \\ \vec{r}' \in \Omega}} \sum_{\vec{R}_\parallel} |J(\vec{r}; \vec{R})|. \quad (3.9)$$

The notation $\vec{r}_{\parallel} \subset \Gamma$ used in the first line of this relation and in various places below indicates that $\vec{r}_{\parallel} = x$ or (x, y) (for $d=1$ or 2) runs over all values lying in the *projection* of Γ onto the x axis or onto the (x, y) plane, respectively [see (3.1) and (3.2)]. From the previous remarks we see that for (a) constant nearest-neighbor interactions, we have $J_{\Gamma}(\vec{R}_{\parallel})$ equal to $|J|$ for nearest neighbors (but vanishing otherwise), while in the case of (b) a nonuniform lattice with a uniform monotonic bound, we have, by (3.6),

$$J_{\Gamma}(\vec{R}_{\parallel}) = \mathfrak{N}_d J_0(|\vec{R}_{\parallel}|), \quad (3.10)$$

so that J_{Γ} may be replaced by $\mathfrak{N}_d J_0$ in (3.8) and all subsequent formulas. [Of course, the average (3.9) may be bounded for all Γ even if there is no uniform bound J_0 .]

Finally, it is convenient to introduce the *d-dimensional* Fourier transform

$$\hat{J}_{\Gamma}(\vec{k}_{\parallel}) = \sum_{\vec{R}_{\parallel} \neq 0} \cos(\vec{k}_{\parallel} \cdot \vec{R}_{\parallel}) J_{\Gamma}(\vec{R}_{\parallel}), \quad (3.11)$$

in terms of which the desired bound is

$$U_1(\vec{k}_{\parallel}, \vec{0}) \leq \tilde{S}^2 \mathfrak{N}(\Gamma) [\hat{J}_{\Gamma}(\vec{0}) - \hat{J}_{\Gamma}(\vec{k}_{\parallel})]. \quad (3.12)$$

This may be compared with (2.29), to which it reduces for nearest-neighbor interactions and small k . We will assume that $\hat{J}_{\Gamma}(\vec{0})$, and hence $\hat{J}_{\Gamma}(\vec{k}_{\parallel})$ exists; this is a weak assumption, not sensibly stronger than the stability condition needed to ensure the existence of a proper thermodynamic limit. From the result (3.12) we will be able to prove that long-range order is absent whenever $[\hat{J}_{\Gamma}(\vec{0}) - \hat{J}_{\Gamma}(\vec{k}_{\parallel})]^{-1}$ is not integrable at $\vec{k}_{\parallel} = 0$.

In order to preserve the analogy with the nearest-neighbor case as closely as possible we introduce an effective wave number $K(\vec{k}_{\parallel})$ by writing

$$\hat{J}_{\Gamma}(\vec{0}) - \hat{J}_{\Gamma}(\vec{k}_{\parallel}) \leq (2d)^{-1} \hat{J}_{\Gamma}(\vec{0}) K^2(|\vec{k}_{\parallel}|) a^2, \quad (3.13)$$

where we may suppose that $K(|\vec{k}_{\parallel}|)$ is chosen to be real, positive, and monotonic nonincreasing as $|\vec{k}_{\parallel}|$ decreases. As $|\vec{k}_{\parallel}| \rightarrow 0$, we want $K(|\vec{k}_{\parallel}|)$ to be the best possible such bound. It is then clear that

$$K(|\vec{k}_{\parallel}|) \rightarrow 0 \text{ as } |\vec{k}_{\parallel}| \rightarrow 0. \quad (3.14)$$

Furthermore, if the mean interaction $J_{\Gamma}(\vec{R}_{\parallel})$, defined in (3.10), decreases sufficiently rapidly that the second moment

$$\sum_{\vec{R}_{\parallel}} (|\vec{R}_{\parallel}|/a)^2 J_{\Gamma}(\vec{R}_{\parallel}) = \mu_2 \hat{J}_{\Gamma}(\vec{0}) \quad (3.15)$$

is finite, it is straightforward to show that we may take

$$K(|\vec{k}_{\parallel}|) = (\mu_2)^{1/2} |\vec{k}_{\parallel}|. \quad (3.16)$$

This justifies the notation and shows (since only the small- \vec{k}_{\parallel} behavior matters) that the nearest-neighbor case is typical of any interaction with a finite second moment.

Turning now to U_2 , the surface contribution to the double commutator, it is easy to obtain the bound

$$U_2 \leq \tilde{S}^2 \mathfrak{N}_d \sum_{\vec{r}_{\parallel} \subset \Gamma} \sum_{\vec{R}_{\parallel}} J^{\sigma}(\vec{r}_{\parallel}; \vec{R}_{\parallel}) \quad (3.17)$$

in terms of the projected interactions (3.4). Quite generally, U_2 vanishes if $\Gamma = \Omega$. Now consider first the two-dimensional situation. For fixed $\vec{R}_{\parallel} = (X, Y) = (la, ma)$ there are $l\mathfrak{N}_Y$ different values of \vec{r}_{\parallel} for which the vector from \vec{r} to $\vec{r} + \vec{R}$ "crosses" one or other of the two bounding X planes $x = \frac{1}{2}a$ and $x = (\mathfrak{N}_X + \frac{1}{2})a$. However, at most $\mathfrak{N}_X \mathfrak{N}_Y$ of these crossings are allowable since \vec{r}_{\parallel} must remain in Γ (strictly, in the projection of Γ). Thus, if we set

$$\begin{aligned} \nu_{\Gamma}^X(\vec{R}_{\parallel}) &= l & \text{for } |X| = la \leq \mathfrak{N}_X a \\ &= \mathfrak{N}_X & \text{for } |X| = la \geq \mathfrak{N}_X a, \end{aligned} \quad (3.18)$$

with a similar definition of $\nu_{\Gamma}^Y(\vec{R}_{\parallel})$, there are a total of $\nu_{\Gamma}^X(\vec{R}_{\parallel}) \mathfrak{N}_Y$ allowable possibilities. We may then define an *average X-surface interaction* by

$$J^X(\vec{R}_{\parallel}) = [\nu_{\Gamma}^X(\vec{R}_{\parallel}) \mathfrak{N}_Y]^{-1} \sum_{\vec{r}_{\parallel} \subset \Gamma} J^{\sigma}(\vec{r}_{\parallel}; \vec{R}_{\parallel}), \quad (3.19)$$

with an analogous definition for $J^Y(\vec{R}_{\parallel})$, where the superscript X indicates that the sum is restricted by

$$x + X > \mathfrak{N}_X a \text{ or } x + X \leq 0. \quad (3.20)$$

The total contribution to U_2 from such surface-interaction pairs is then bounded by summing over all \vec{R}_{\parallel} , which gives

$$U_2^X \leq \tilde{S}^2 \mathfrak{N}_d \mathfrak{N}_Y \sum_{\vec{R}_{\parallel}} \nu_{\Gamma}^X(\vec{R}_{\parallel}) J^X(\vec{R}_{\parallel}). \quad (3.21)$$

If we combine this with the analogous U_2^Y term, we will actually overcount all those interactions for which the vector \vec{r} to $\vec{r} + \vec{R}$ crosses *both* an X and a Y plane. We can write the final bound as

$$U_2 \leq \tilde{S}^2 \mathfrak{N}_d J_{\Delta}, \quad (3.22)$$

where, now,

$$\mathfrak{N}_{\Delta} = 2\mathfrak{N}_d (\mathfrak{N}_X + \mathfrak{N}_Y), \quad d=2 \quad (3.23)$$

while the *mean surface moment of the interactions* is

$$J_{\Delta} = \max_{\beta=X, Y} \left\{ \frac{1}{2} \sum_{\vec{R}_{\parallel}} \nu_{\Gamma}^{\beta}(\vec{R}_{\parallel}) J^{\beta}(\vec{R}_{\parallel}) \right\}. \quad (3.24)$$

In the case of nearest-neighbor interactions these results reduce effectively to the previous bound (2.32); if (a) the nearest-neighbor interaction is constant at J , we have, as before, $J_{\Delta} = |J|$. For (b) a nonuniform system with the uniform monotonic bound (3.5), we find, using (3.6), that

$$\begin{aligned} J_{\Delta} &\leq \frac{1}{2} \mathfrak{N}_d \sum_{\vec{R}_{\parallel}} \nu_{\Gamma}^X(\vec{R}_{\parallel}) J_0(|\vec{R}_{\parallel}|) \\ &\leq \frac{1}{2} \mathfrak{N}_d \sum_{\vec{R}_{\parallel}} (|\vec{R}_{\parallel}|/a) J_0(|\vec{R}_{\parallel}|). \end{aligned} \quad (3.25)$$

The last expression is just proportional to the first moment of the bound $J_0(|\vec{R}_\parallel|)$. Either of the estimates in (3.25) may be used in place of J_Δ in the subsequent work; in particular, the first bound may be useful when the full first moment does not even exist.

In the one-dimensional situation ($d=1$) the corresponding analysis is simpler since only a single pair of surfaces (X planes) arise, and there is no overcounting. The relations (3.19)–(3.21) then still apply if, as is natural, we simply set $N_Y=1$. The final bound (3.22) remains valid if we now take

$$\mathfrak{X}_\Delta = 2\mathfrak{X}_d, \quad d=1 \quad (3.26)$$

while (3.24) applies with $\beta=X$, and (3.25) is correct as it stands. (In all $d=1$ cases the sums on \vec{R}_\parallel are, of course, purely one dimensional.) When $\Gamma=\Omega$, we may set $\mathfrak{X}_\Delta=0$ for both $d=1$ and $d=2$.

We are now in a position to write down a complete bound for the double commutator to generalize (2.33). By combining (2.7), (3.12), (3.13), and (3.22) we obtain

$$\langle [C, \mathfrak{X}_\alpha], C^\dagger \rangle \leq (2d)^{-1} a^2 \bar{S}^2 \hat{J}_\Gamma(\vec{0}) \mathfrak{X}(\Gamma) [K^2(\vec{k}_\parallel) + \lambda], \quad (3.27)$$

where, to replace (2.34), we have

$$a^2 \lambda = \mu_1 [\mathfrak{X}_\Delta / \mathfrak{X}(\Gamma)] + [2d / \hat{J}_\Gamma(\vec{0}) \bar{S}^2] H\{\vec{h}_\parallel; \Gamma\}, \quad (3.28)$$

in which [in place of the definition in (2.58)] we have

$$\mu_1 = J_\Delta / (2d)^{-1} \hat{J}_\Gamma(\vec{0}), \quad (3.29)$$

which should also be compared to the ratio J_Δ / J_Γ in (2.34). The symmetry-breaking field term $H\{\vec{h}_\parallel; \Gamma\}$ is still defined by (2.35). Again we assume that as $N \rightarrow \infty$ this term vanishes as fast as the first term, i. e., as fast as $\mathfrak{X}_\Delta / \mathfrak{X}(\Gamma) \rightarrow 0$, unless this ratio vanishes identically because $\Gamma=\Omega$.

On integrating the right-hand side of Bogoliubov's inequality (1.7) subject to (2.17) and dropping a positive term as before, we find

$$\begin{aligned} R &= (a/2\pi)^d \int_{\kappa} d\vec{k}_\parallel R(\vec{k}_\parallel, \vec{0}) \\ &\geq \frac{2dk_B T \mathfrak{X}(\Gamma)}{a^2 \bar{S}^2 \hat{J}_\Gamma(\vec{0})} [n^2 \{f\} a^d g(\kappa, \lambda) - 2n \{f\} g(\kappa, \lambda)]. \end{aligned} \quad (3.30)$$

In place of (2.40) we have the integral

$$g(\kappa, \lambda) = (2\pi)^{-d} \int_{\kappa} d\vec{k}_\parallel [K^2(|\vec{k}_\parallel|) + \lambda], \quad (3.31)$$

whose divergence as $\kappa, \lambda \rightarrow 0$ will have to be examined in more detail. For the second integral we have

$$g(\kappa, \lambda) = (a/2\pi)^d \int_{\kappa} d\vec{k}_\parallel n \{f e^{i\vec{k} \cdot \vec{r}}\} / [K^2(|\vec{k}_\parallel|) + \lambda], \quad (3.32)$$

which, by following the steps used in analyzing (2.41) and recalling the monotonicity of $K(|\vec{k}_\parallel|)$,

is shown to satisfy

$$g(\kappa, \lambda) \leq \mathfrak{X}_d [K^2(\kappa) + \lambda]^{-1} [\bar{S}^2 + M_\Omega^s(\Gamma)], \quad (3.33)$$

where $M_\Omega^s(\Gamma)$ is still defined by (2.43). Continuing the previous arguments, we finally obtain

$$\Psi_\Omega^2 \{f | \Gamma\} \leq \frac{q_1(X)}{q_0 g(\kappa, \lambda)} + \frac{q_2}{q_1(X) \mathfrak{X}(\Gamma)}, \quad (3.34)$$

where, as before, $q_1(X) = 1 + q_1/X$, but now

$$X = \mathfrak{X}(\Gamma) [K^2(\kappa) + \lambda], \quad (3.35)$$

while

$$q_0 = [2dk_B T / \hat{J}_\Gamma(\vec{0})] [a^{d-2} / \bar{S}^4 \mathfrak{X}_d], \quad (3.36)$$

$$q_1 = [2dk_B T / \hat{J}_\Gamma(\vec{0})] (2/a^2 \bar{S}^4) [\bar{S}^2 + M_\Omega^s(\Gamma)], \quad (3.37)$$

and

$$q_2 = (S/\bar{S}^2) [\bar{S}^2 + M_\Omega^s(\Gamma)]. \quad (3.38)$$

Note that with the substitutions $\hat{J}_\Gamma(\vec{0})/2d \Rightarrow J_\Gamma$ (or $J_{\Gamma \cup \Delta}$ with the inclusion of a corridor), $K^2(\kappa) \Rightarrow \kappa^2$, and $g(\kappa, \lambda) \Rightarrow I(\kappa, \lambda)$, these expressions are identical with (2.46)–(2.51) [see (2.59)–(2.61)].

IV. ANALYSIS OF BASIC INEQUALITY

In this section we derive the results for spin systems quoted in the Introduction from the basic inequality (3.34) [or, for nearest-neighbor interactions, (2.45)]. We will be interested in the *thermodynamic limit* in which $\mathfrak{X}(\Omega) \rightarrow \infty$. For the existence of this limit the interaction potentials and the external fields (even if random) must satisfy certain uniformity and regularity conditions.⁸ We need not enter into these in any detail but we will assume, first, that the domain Ω and the subdomain Γ have regular shapes as $\mathfrak{X}(\Omega)$ and $\mathfrak{X}(\Gamma)$ become infinite, in the sense that their (d -dimensional) "surface" remains of order $[\mathfrak{X}(\Omega)]^{-1/d}$ or $[\mathfrak{X}(\Gamma)]^{-1/d}$ relative to their "volume." Secondly, we suppose that the basic averages of the potentials $J_\Gamma(\vec{R}_\parallel)$, $J^X(\vec{R}_\parallel)$, and $J^Y(\vec{R}_\parallel)$ and the transform $\hat{J}_\Gamma(\vec{k}_\parallel)$, defined in Eqs. (3.9), (3.19), and (3.11), approach definite limits as $\mathfrak{X}(\Gamma) \rightarrow \infty$. Similarly, the magnetization $M_\Omega^s(\Gamma)$ may be assumed to approach a limit for large Ω and Γ . Then from (3.36)–(3.38) [or from (2.46)–(2.48), or (2.59)–(2.61)] we see that the parameters q_0 , q_1 , and q_2 approach limits. We will not distinguish these limits by any special symbol since the context of each formula will make it clear when the limiting values are required. As regards the transverse fields we may, for concreteness, assume that

$$h^*(\vec{r}) = h_x(\vec{r}) + i h_y(\vec{r}) = h_1 e^{i\vec{K} \cdot \vec{r}}, \quad (4.1)$$

where h_1 and \vec{K} are fixed. We could, with no difficulty, however, consider, for example, randomly varying fields of given statistics provided their over-all average magnitude could be bounded by

some amplitude parameter, which might then be called h_\perp .

Having disposed of these preliminaries, we turn to the main task: First we treat the case where Γ is chosen to be Ω in order to prove the absence of total order in the thermodynamic limit and to show how the *long* long-range order⁹ vanishes as $\mathfrak{N}(\Omega)$ becomes large.

$$A. \Gamma \equiv \Omega$$

In this case Δ is null and there are no corridor "surface" terms for Γ , so that \mathfrak{N}_Δ and $\mathfrak{N}(\Delta)$ are to be set identically zero [see after Eqs. (2.35), (2.62) and (3.26)]. Hence (3.28) represents all cases. Only the external transverse fields $\vec{h}_\perp = (h_x, h_y)$ contribute to λ , so that by (3.28) [or by (2.34) or (2.58) with $J_\Gamma \Rightarrow \hat{J}_\Gamma(\vec{0})/2d$] and (4.1),

$$\begin{aligned} \lambda &= [2d/\hat{J}_\Gamma(\vec{0})\bar{S}^2 a^2] H\{\vec{h}_\perp; \Omega\} \\ &\leq [4dS/\hat{J}_\Gamma(\vec{0})\bar{S}^2 a^2] |h_\perp|, \end{aligned} \quad (4.2)$$

where we have used the trivial bounds $|\langle S^z(\vec{r}) \rangle|, |\langle S^y(\vec{r}) \rangle| \leq S$. There are two possibilities we may consider.

1. \vec{h}_\perp Fixed, $\mathfrak{N}(\Omega) \rightarrow \infty$

This is the situation which may be analyzed in closest analogy to the original treatment of Mermin and Wagner.¹⁰ By (4.3) and (2.35) it is clear that $\lambda \rightarrow 0$ as $|h_\perp| \rightarrow 0$, but that λ will not vanish unless h_\perp does. In the thermodynamic limit the order parameter approaches a limiting value, i. e.,

$$\Psi_\Omega\{f|\Omega\} \rightarrow \Psi_{\sigma\{f\}}(h_\perp), \quad \mathfrak{N}(\Omega) \rightarrow \infty \quad (4.3)$$

with an obvious extension of the previous notation [see (I 2.16)]. If, in the basic inequality (3.34) [or (2.50)], we now choose $\kappa = 0$ and keep κ^\dagger constant as $\mathfrak{N}(\Omega) \rightarrow \infty$, we obtain

$$[\Psi_{\sigma\{f\}}(h_\perp)]^2 \leq 1/q_0 \mathcal{G}(0, \lambda), \quad (4.4)$$

where, in (3.35), we have $X \rightarrow \infty$, and where, by (3.31),

$$\mathcal{G}(0, \lambda) = \frac{2^{1-d}}{\pi} \int_0^{\kappa^\dagger} \frac{k^{d-1} dk}{K^2(k) + \lambda}, \quad d=1, 2. \quad (4.5)$$

Thus, if $\mathcal{G}(0, \lambda)$ diverges to infinity as $\lambda \rightarrow 0$ (as $|h_\perp| \rightarrow 0$), the inequality (4.4) implies the vanishing to the "total" long-range order, that is,

$$\Psi_{\sigma\{f\}}^0 = \lim_{|h_\perp| \rightarrow 0} \Psi_{\sigma\{f\}}(h_\perp) = 0. \quad (4.6)$$

Evidently, the divergence or convergence of the integral (4.5) is determined by the behavior of $K(k)$ for small k .

If (a) the mean projected interaction $J_\Gamma(\vec{R}_\parallel) = J_\Omega(\vec{R}_\parallel)$ has a *uniformly bounded second moment* as $\mathfrak{N}(\Omega) \rightarrow \infty$ [see (3.15)], as is certainly so for nearest-neighbor interactions, we have $K(k) \approx \mu_2^{1/2} k$ [see (3.16)]. The

reduced second moment μ_2 is defined in (3.15) and, in accordance with our remarks at the start of this section, approaches a limit as $\mathfrak{N}(\Omega) \rightarrow \infty$. (For nearest-neighbor interactions, $\mu_2 \equiv 1$.) Then as $\lambda \rightarrow 0$ we obtain

$$\begin{aligned} \mathcal{G}(0, \lambda) &\approx (\pi^2 \mu_2 \lambda)^{-1/2} \tan^{-1}(\kappa^\dagger \mu_2^{1/2} / \lambda^{1/2}), \quad d=1 \\ &\approx (1/4\pi \mu_2) \ln[1 + (\kappa^\dagger \mu_2 / \lambda)], \quad d=2. \end{aligned} \quad (4.7)$$

[Compare with (I 3.22).] Clearly $\mathcal{G}(0, \lambda)$ now diverges as $|h_\perp| \rightarrow 0$ and the result (4.6), expressing the vanishing of the total long-range order, follows whenever the dimensionality is restricted to less than three.

More generally, (b) suppose that $J_\Gamma(\vec{R}_\parallel)$ does not have a finite second moment but that, for example,

$$K(k) \approx c_1 k^d \ln k \quad \text{as } k \rightarrow 0. \quad (4.8)$$

It is not hard to see that the integral (4.5) defining $\mathcal{G}(0, \lambda)$ will still diverge at its lower limit when $\lambda \rightarrow 0$. This means that even for interactions decaying as $R \rightarrow \infty$ as slowly as¹¹

$$J_\Gamma(R) \approx C_1 \ln(R/a)/R^2, \quad d=1 \quad (4.9)$$

$$\approx C_1/R^4, \quad d=2 \quad (4.10)$$

the vanishing of the total long-range order $\Psi_{\sigma\{f\}}^0$ can be proven. Neither of these functions has a finite second moment [in the appropriate sense, (3.15)], and the function (4.9) for $d=1$ does not even have a finite first moment. Other, even more slowly decaying examples can be found; the main point is that the absence of long-range order can be established whenever $\mathcal{G}(0, \lambda)$ diverges as $\lambda \rightarrow 0$ or, equivalently, whenever $[\hat{J}_\Gamma(\vec{0}) - \hat{J}_\Gamma(\vec{k}_\parallel)]^{-1}$ is not integrable at $\vec{k}_\parallel = 0$. The same conclusion will hold for all the forms of order we will investigate.¹²

We may, to answer the fundamental question raised in the Introduction, avoid altogether the case of a symmetry breaking field; thus we consider the second possibility.

2. $\vec{h}_\perp \equiv 0$

In this case $\lambda \equiv 0$ and the basic inequality (3.34) becomes, with $X = \kappa^2 \mathfrak{N}(\Omega)$,

$$\Psi_\Omega^2 \leq \frac{1}{q_0 \mathcal{G}(\kappa, 0)} \left[1 + \frac{q_1}{\kappa^2 \mathfrak{N}(\Omega)} \right] + \frac{q_2}{q_1(X) \mathfrak{N}(\Omega)}. \quad (4.11)$$

Suppose again in the first place (a) that $J_\Gamma(\vec{R}_\parallel) = J_\Omega(\vec{R}_\parallel)$ has a uniformly bounded second moment (3.15). Then from (4.5) and (3.14) we find¹³ as $\kappa \rightarrow 0$

$$\begin{aligned} \mathcal{G}(\kappa, 0) &\approx (1/\pi \mu_2)(\kappa^{-1} - \kappa^{\dagger-1}), \quad d=1 \\ &\approx (1/2\pi \mu_2) \ln(\kappa^\dagger/\kappa), \quad d=2. \end{aligned} \quad (4.12)$$

[Compare with (I 3.22).] We are now free to choose

the lower cutoff κ as a function of $\mathfrak{X}(\Omega)$ in such a way as to yield the best inequality. Consider first the case $d=1$ and, tentatively, ignore the second term in the inequality (4.11). By minimizing with respect to κ at fixed $\mathfrak{X}(\Omega)$ we find the optimal choice is

$$\kappa^2 = q_1/\mathfrak{X}(\Omega) \quad , \quad (4.13)$$

up to a correction factor $\{1 + O[1/\kappa^\dagger \mathfrak{X}^{1/2}(\Omega)]\}$. For fixed κ^\dagger this correction term can be neglected for large $\mathfrak{X}(\Omega)$. Thus, $\mathcal{J}(\kappa, 0)$ may be maximized by choosing κ^\dagger in (4.12) as large as consistent with (2.17), namely, $\kappa^\dagger = \pi/a$. Use of (4.13) now yields

$$q_1(X) = 2 \quad , \quad (4.14)$$

and thence, from (4.11) and (4.12),¹³

$$[\Psi_\Omega\{f|\Omega\}]^2 \leq \frac{2\pi\mu_2 q_1^{1/2}}{q_0[\mathfrak{X}(\Omega)]^{1/2}} + \frac{q_2}{\mathfrak{X}(\Omega)} \quad , \quad d=1 \quad . \quad (4.15)$$

Asymptotically as $\mathfrak{X}(\Omega) \rightarrow \infty$ the second term is negligible and $\Psi_\Omega\{f|\Omega\}$ must decrease at least as fast as $[\mathfrak{X}(\Omega)]^{-1/4}$, which indicates how the *long* long-range order⁹ falls to zero. If the thermodynamic limit is taken with $f(\vec{r}) \equiv 1$, we find directly from (4.15) that $\Psi_\sigma \equiv 0$, where

$$\Psi_\sigma^2 = \lim_{\mathfrak{X}(\Omega) \rightarrow \infty} \mathfrak{X}(\Omega)^{-2} \sum_{\vec{r} \in \Omega} \sum_{\vec{r}' \in \Omega} \sigma_\Omega(\vec{r}, \vec{r}') \quad , \quad (4.16)$$

so that Ψ_σ is the limiting mean-square total magnetization per spin. [Compare with (2.16).] Of course, (4.15) is more general in that, for example, if we set

$$f(\vec{r}) = e^{i\vec{k}_0 \cdot \vec{r}} \quad \text{with } a\vec{k}_0 = (\pi, \pi, \pi) \quad , \quad (4.17)$$

then $\Psi_{\sigma(f)}$ represents the mean square sublattice magnetization for simple *antiferromagnetic* ordering which must also vanish in the thermodynamic limit. Other forms of ordering are ruled out by appropriate choice of $f(\vec{r})$ [subject only to the original condition $|f(\vec{r})| = 1$].

The same choice (4.13) is quite satisfactory for $d=2$, where it leads to¹³

$$[\Psi_\Omega\{f|\Omega\}]^2 \leq \frac{8\pi\mu_2}{q_0 \ln[\kappa^{1/2} \mathfrak{X}(\Omega)/q_1]} + \frac{1}{2} \frac{q_2}{\mathfrak{X}(\Omega)} \quad , \quad d=2 \quad . \quad (4.18)$$

Again the first term dominates asymptotically as $\mathfrak{X}(\Omega) \rightarrow \infty$, and we conclude that Ψ_Ω must fall to zero but, possibly, only as slowly as $[\ln \mathfrak{X}(\Omega)]^{1/2}$. However this is still sufficient to prove that Ψ_σ and its generalization $\Psi_\Omega\{f|\Omega\}$ vanish in the thermodynamic limit. A numerically better bound results by choosing $\kappa^\dagger = \pi/a$ and $\kappa^2 \propto [\ln \mathfrak{X}(\Omega)]/\mathfrak{X}(\Omega)$ in place of (4.13). This choice reduces the factor 8π in the first term of (4.18) to 4π ; this detail, however, is immaterial for the present purpose.

When (b) the *second moment* as measured by μ_2 , is not finite, we may still establish the vanishing

of Ψ_σ provided $\mathcal{J}(\kappa, 0)$ diverges to ∞ as $\kappa \rightarrow 0$. As before, this will be so whenever $[\mathcal{J}_\Gamma(\vec{0}) - \mathcal{J}_\Gamma(\vec{k}_\parallel)]^{-1}$ is not integrable at $\vec{k}_\parallel = 0$. In particular, interactions decaying as (4.10) or faster are still covered. However, the rate at which the long long-range order can be shown to decay to zero will now depend on the rate of divergence of $\mathcal{J}(\kappa, 0)$ and will necessarily be slower than when $\mu_2 < \infty$.

Lastly, it should be noticed that if transverse magnetic fields like (4.1) are present in Ω but are reduced uniformly to zero as $\mathfrak{X}(\Omega) \rightarrow \infty$, the results $\Psi_\sigma \equiv 0$, etc., remain valid. Proofs similar to the above go through in this (particular) thermodynamic limit. All the arguments are quite independent of the magnitude of any longitudinal field $h_z(\vec{r})$.

We turn next to the case where Γ is a proper, slice subdomain of Ω (i. e., $\Gamma \neq \Omega$).

B. $\Gamma \subset \Omega$

The analysis must be modified slightly now since λ does not vanish even in zero transverse field, $h_\perp = 0$. Rather, as can be verified from (2.34), (2.58), and (3.28), λ contains a surface term $\mu_1(1-\gamma)\nu^{-2}[\mathfrak{X}_\Delta/\mathfrak{X}(\Gamma)]$, where $\nu=1$, $\gamma=0$ in the case of long-range interactions, and μ_1 is given by (3.29). In the nearest-neighbor case we have

$$\begin{aligned} \mu_1 &= J_\Delta/J_\Gamma \quad \text{for } \nu=1 \text{ (no corridor)} \\ &= J_\Delta/J_{\Gamma \cup \Delta} \quad \text{for } \nu>1 \text{ (corridor } \Delta) \quad , \quad (4.19) \end{aligned}$$

where the appropriate exchange constants are defined by (2.27), (2.28), ($\Gamma \Rightarrow \Gamma \cup \Delta$ for a corridor) and by (2.30), (2.31), or (2.55), (2.56). The surface term allows for the propagation of order *into* the subdomain Γ from the rest of the system. Nevertheless, as Γ becomes large [$\mathfrak{X}(\Gamma) \rightarrow \infty$], we will have $\mathfrak{X}_\Delta/\mathfrak{X}(\Gamma) \rightarrow 0$ in accordance with our assumptions on the shape of Γ [see (2.30), (2.55) for fixed ν , and (3.22) and (3.26)]. Thus, provided the moment μ_1 remains bounded [see (3.29), (3.24), and (4.19)], or does not increase too rapidly, and provided the transverse fields vanish in Γ , we will still have $\lambda \rightarrow 0$ as $\mathfrak{X}(\Gamma) \rightarrow \infty$. If the transverse fields in Γ are not zero, we will assume that $|\vec{h}_\perp|$ is reduced to zero sufficiently rapidly that the first (surface) term in (2.34), (2.58), and (3.28) dominates as $\mathfrak{X}(\Gamma)$ becomes large. We stress, however, that *transverse* (symmetry-breaking) *fields outside* Γ (for example, in the corridor, should there be one) are *allowed* and will not effect the proof that the order inside Γ must decay to zero.

Since λ does not vanish for finite $\mathfrak{X}(\Gamma)$, we may, with no loss of generality, choose $\kappa=0$. The upper-cutoff κ^\dagger and the corridor width ν (in the case of nearest-neighbor interactions) are still disposable parameters.

1. $d=1$

For simplicity let us start with (a) the situation

in which the (projected) interactions have a *uniform monotonic bound* $J_0(|\vec{R}_n|)$ which has a *finite second moment*.¹⁴ By (3.10) and (3.15) this implies that μ_2 is uniformly bounded and by (3.25) and (3.29) the same holds for the "surface moment" μ_1 . Using (4.7) the inequality becomes¹³

$$[\Psi_\Omega\{f|\Gamma\}]^2 \leq \frac{2q_1(X)\mu_2^{1/2}\lambda^{1/2}}{q_0[(2/\pi)\tan^{-1}(\kappa^\dagger\mu_2^{1/2}/\lambda^{1/2})]} + \frac{q_2}{q_1(X)\mathfrak{A}(\Gamma)}. \quad (4.20)$$

This inequality is optimized with respect to κ^\dagger by choosing κ^\dagger as large as possible, i. e., $\kappa^\dagger = \pi/a$. (This contrasts with the more complex κ^\dagger optimization in the Bose case; see Sec. IV of I.) Suppose, first, that in the nearest-neighbor case we *fix* the corridor width ν . Now, since μ_1 is uniformly bounded, we find from (3.26) and (3.28) [or (2.55) and (2.58)] that

$$\lambda = \mu_1(1-\gamma)(\nu a)^{-2}[\mathfrak{A}_\Delta/\mathfrak{A}(\Gamma)] \sim [\mathfrak{A}(\Gamma)]^{-1} \quad (4.21)$$

as $\mathfrak{A}(\Gamma) \rightarrow \infty$

(which is valid for $\nu \equiv 1$ and $\gamma = 0$ in the long-range case); as explained before, the h_1 -dependent terms have been neglected in (4.21). Then as $\lambda \rightarrow 0$ we have $\kappa^\dagger\mu_2^{1/2}/\lambda^{1/2} \rightarrow \infty$, so that the denominator of the first term in (4.20) approaches q_0 . Similarly, on recalling that $\kappa = 0$, the definition (3.35) shows that $X \rightarrow \mu_1\mathfrak{A}_\Delta(1-\gamma)(\nu a)^{-2}$, which remains bounded (as before, we set $\gamma = 0$, $\nu = 1$ for general interactions). It is then clear from (4.20) and (4.21) that the short-range order $\Psi_\Omega\{f|\Gamma\}$ must decrease asymptotically at least as fast as $[\mathfrak{A}(\Gamma)]^{-1/4}$. This confirms the conclusion stated in the Introduction.

In the case of *nearest-neighbor interactions* the inequality (4.20) can be optimized with respect to the corridor width ν [see Sec. IV of I]. The inequality depends on the integer ν mainly through λ and hence through X , but there is also a dependence in q_1 and q_0 via the parameter γ . Strictly, the inequality should be optimized numerically (see Sec. V), but in order to perform an approximate optimization analytically we consider ν to be a continuous variable. On neglecting the second term in (4.20) we then find that the optimum value $\nu = \nu^*$ is not far from the solution of

$$[X^*]^{-1} \equiv (\nu^* a)^2 / \mu_1 \mathfrak{A}_\Delta^*(1-\gamma^*) = q_1^{-1}, \quad (4.22)$$

where the asterisk notation indicates that \mathfrak{A}_Δ and γ depend on ν . When there is an acceptable solution to (4.22), we have $q_1(X) \approx 2$, and the inequality (4.20) becomes¹⁵

$$[\Psi_\Omega\{f|\Gamma\}]^2 \leq \frac{4q_1^{1/2}t}{q_0[\mathfrak{A}(\Gamma)]^{1/2}} + \frac{q_2}{2\mathfrak{A}(\Gamma)}, \quad (4.23)$$

where

$$t^{-1} = (2/\pi)\tan^{-1}\{\pi[\mathfrak{A}(\Gamma)]^{1/2}/q_1^{1/2}a\}. \quad (4.24)$$

Note that t approaches unity for large $\mathfrak{A}(\Gamma)$ and that we have set $\mu_2 \equiv 1$ for nearest-neighbor interactions. Recall that q_0 , q_1 , and q_2 are given for this case in (2.59)–(2.61). The numerical consequences and the temperature dependence of the optimized inequality (4.23) will be explored in Sec. V.

We consider now the more general case of long-range interactions (b) in which we suppose that *only the surface moment* μ_1 is finite as $\mathfrak{A}(\Gamma) \rightarrow \infty$, as is the case when there is a monotonic bound, satisfying

$$J_0(|\vec{R}_n|) \approx C_0/|\vec{R}_n|^{1+\sigma} \quad (4.25)$$

as $|\vec{R}_n| \rightarrow \infty$ with $2 > \sigma > 1$,

where C_0 is a constant. With the range of σ specified, $J_\Gamma(|\vec{R}_n|)$ will always have a first moment, but it need not have a second moment. From (4.25) we can conclude that¹¹

$$K^2(k) \leq c_0 k^\sigma \quad \text{as } k \rightarrow 0, \quad (4.26)$$

and hence that

$$\mathfrak{g}(0, \lambda) \geq I_0 \lambda^{-(\sigma-1)/\sigma} \quad \text{as } \lambda \rightarrow 0, \quad (4.27)$$

where c_0 and I_0 are constants. Since μ_1 is uniformly bounded, this in turn implies the result

$$\Psi_\Omega\{f|\Gamma\} \leq \Phi_0[\mathfrak{A}(\Gamma)]^{-(\sigma-1)/2\sigma} \quad \text{as } \mathfrak{A}(\Gamma) \rightarrow \infty, \quad (4.28)$$

where Φ_0 is constant. Thus the short-range order must still decrease, but it may do so more slowly than when $\mu_2 < \infty$.

Lastly, we may consider the case in which (c) the *surface moment* $\mu_1 = \mu_1(\Gamma)$ is *not bounded* as $\mathfrak{A}(\Gamma) \rightarrow \infty$. In order that $\mathfrak{g}(0, \lambda) \rightarrow \infty$ as $\lambda \rightarrow 0$ we must still require that $[\hat{J}_\Gamma(\vec{0}) - \hat{J}_\Gamma(|\vec{k}_n|)]^{-1}$ is not integrable at the origin, which, as illustrated in the discussion of (4.8)–(4.10), does not allow much latitude beyond (4.25). All we need to worry about, beyond this, is the behavior of λ as $\mathfrak{A}(\Gamma) \rightarrow \infty$. To check that λ still vanishes in the limit let us suppose the bound (4.25) holds but with $1 > \sigma > 0$. If we use the first inequality of (3.25), we find without difficulty that

$$\mu_1(\Gamma) \leq M_1 \mathfrak{A}_X^{1-\sigma} \sim [\mathfrak{A}(\Gamma)]^{1-\sigma}, \quad (4.29)$$

where M_1 is a constant. It follows that (4.21) must be replaced by

$$\lambda \approx \mu_1 \mathfrak{A}_\Delta / \mathfrak{A}(\Gamma) a^2 \sim [\mathfrak{A}(\Gamma)]^{-\sigma}. \quad (4.30)$$

Thus $\lambda \rightarrow 0$ as $\mathfrak{A}(\Gamma) \rightarrow \infty$ and the proof that the short-range order decays to zero goes through under the original condition that $[\hat{J}_\Gamma(\vec{0}) - \hat{J}_\Gamma(|\vec{k}_n|)]^{-1}$ is not integrable at $\vec{k}_n = 0$.¹⁶

The last case to analyze is $d = 2$.

2. $d = 2$

If (a) the (projected) interactions have a *uniform monotonic bound* with a finite *second moment* (as

assumed when $d=1$),¹⁴ the basic inequality becomes¹³

$$[\Psi_{\Omega}\{f|\Gamma\}]^2 \leq \frac{4\pi\mu_2 q_1(X)}{q_0 \ln[1+(\kappa^{\dagger 2}\mu_2/\lambda)]} + \frac{q_2}{q_1(X)\mathfrak{N}(\Gamma)}, \quad (4.31)$$

where we have used (3.16) and (4.7). The inequality is optimized with respect to κ^{\dagger} with the choice $\kappa^{\dagger} = \pi/a$. Suppose first that in the nearest-neighbor case we fix the corridor width ν . The surface moment μ_1 is uniformly bounded and from (3.28) we have (with $\gamma=0$ and $\nu=1$ in the long-range case)

$$\lambda \approx \mu_1(1-\gamma)(\nu a)^{-2} [\mathfrak{N}_{\Delta}/\mathfrak{N}(\Gamma)] \sim [\mathfrak{N}(\Gamma)]^{-1/2} \quad \text{as } \mathfrak{N}(\Gamma) \rightarrow \infty. \quad (4.32)$$

On using the simplified geometry (3.1) and its consequence (3.23), this becomes

$$\lambda \approx 2\mu_1 \mathfrak{N}_d(\mathfrak{N}_x + \mathfrak{N}_y)/\mathfrak{N}(\Gamma)a^2 \sim [\mathfrak{N}(\Gamma)]^{-1/2} \quad (\text{no corridor}) \quad (4.33)$$

as $\mathfrak{N}(\Gamma) \rightarrow \infty$. It follows from (3.35) that X now diverges as $[\mathfrak{N}(\Gamma)]^{1/2}$, so that $q_1(X) \rightarrow 1$. The second term in (4.31) is asymptotically negligible, so that we have established that $\Psi_{\Omega}\{f|\Gamma\}$ decays to zero at least as fast as $[\ln\mathfrak{N}(\Gamma)]^{-1/2}$ as stated in the Introduction.

In the *nearest-neighbor case* we can, as for $d=1$, optimize the inequality (4.31) by proper choice of the corridor width ν (compare with Sec. IV of I). This will be performed numerically in Sec. V below, but may usefully be performed approximately by treating ν as a continuous variable. The terms in (4.31) depend strongly on ν through λ and X and more weakly through q_1 and q_0 . Under the assumption $\gamma \ll 1$ (i. e., a corridor of volume small relative to that of Γ) this latter dependence may be ignored. On recalling that \mathfrak{N}_{Δ} depends on ν and that $\mu_2=1$ for nearest-neighbor interactions we find that the optimum value of ν not far from the solution ν^* of

$$X^* \equiv (\nu^* a)^{-2} \mu_1(1-\gamma^*)\mathfrak{N}_{\Delta}^* = q_1[\mathcal{L} - \ln\mathcal{L}], \quad (4.34)$$

where

$$\mathcal{L} = \mathcal{L}(\Gamma) = \ln[\pi^2\mathfrak{N}(\Gamma)/q_1 e a^2] \gg 1. \quad (4.35)$$

Substituting into (4.31) with this value of ν^* (strictly we should take ν to be the nearest integer) yields

$$[\Psi_{\Omega}\{f|\Gamma\}]^2 \leq \frac{4\pi/q_0}{\mathcal{L} - \ln\mathcal{L}} + \frac{q_2}{(1 + \mathcal{L}^{-1})\mathfrak{N}(\Gamma)}, \quad (4.36)$$

which is valid for large enough $\mathfrak{N}(\Gamma)$, and T not too high (see Sec. V). The detailed implications of this result will be discussed in Sec. V.

Again (b) the condition requiring $J_{\Gamma}(\vec{R}_{\parallel})$ to have a second moment, may be relaxed somewhat. Thus, if we had only $J_0(|\vec{R}_{\parallel}|) \approx C_0/R^4$ [compare with (4.8) and (4.10)], we would conclude that

$\Psi_{\Omega}\{f|\Gamma\}$ decreases no more slowly than $[\ln \ln\mathfrak{N}(\Gamma)]^{-1/2}$. Other examples with a still slower decay can be constructed without trouble.

Before presenting the actual numerical consequences of the inequalities it is worth commenting on the differences between the above treatment of spin systems and the previous treatment of Bose systems (I, Sec. IV). There are a number of simplifications: The first is that, since we are dealing with a lattice, there is no risk of "ultraviolet" divergences. In particular, although it proved to be convenient, we did not need to introduce a "corridor" Δ surrounding Γ as was essential in the continuum case to avoid unbounded gradients. Furthermore, the localized spin operators are all bounded operators in contrast to the Bose density operator for a continuum. Hence in the spin case no analysis was necessary to bound the local density fluctuations; specifically we had no analog of the integral $Q\{f\}$ of (I 3.29), which was analyzed in the Appendix of I. In this respect the spin system resembles a hard-core Bose system and, indeed, can be regarded as representing a quantum lattice gas.¹⁷ A further simplification arises since the spin commutation rules generate no singular terms, so that integration of the left-hand side of the Bogoliubov inequality can be extended immediately to all \vec{k} . This avoids extra terms containing the upper cutoff κ^{\dagger} appearing in (4.20) and (4.31), which greatly simplifies the optimization of the inequalities.

On the other hand, in a Bose system the kinetic energy is always a translationally invariant local operator corresponding to a constant short-range interaction with a finite second moment. No analog of $K(k)$ was needed in the Bose case, nor were there complications in estimating the long-range surface or bulk interactions or in allowing for randomness and non-uniformity. We will see in the next section that the lack of "locality" prevents the inequalities for the spin systems from becoming progressively stronger as the temperature approaches infinity, as is, in fact, the case for Bose systems.

V. NUMERICAL CONSEQUENCES

It is instructive to analyze our results somewhat further in order to obtain concrete numerical bounds on the summed correlation function

$$\sigma(\vec{r}, \vec{r}') = \langle S^+(\vec{r}') S^-(\vec{r}) \rangle.$$

We shall assume the transverse fields $\vec{h}_{\perp}(\vec{r})$ vanish identically in $\Gamma \cup \Delta$.¹⁸ The longitudinal fields $h_z(\vec{r})$ play only a small role in the analysis [they enter via the magnetization $M_z^{\Omega}(\Gamma)$; see (3.37) and (3.38)], but on heuristic grounds it is clear that a field in the z direction will tend to reduce the transverse correlations. Hence we expect our bounds to have most force when $h_z(\vec{r}) \equiv 0$; we shall assume this, and also, as a corollary, $M_z^{\Omega}(\Gamma) = 0$. Similarly, the

magnitude of $J_z(\vec{r}, \vec{r}')$ relative to $J_x(\vec{r}, \vec{r}') = J_y(\vec{r}, \vec{r}')$ does not enter the analysis at all. Nevertheless, it is again clear physically that large values of J_z will oppose the transverse coupling, so that the bounds will be most informative when $|J_z(\vec{r}, \vec{r}')| \leq J_x(\vec{r}, \vec{r}')$, in which case the transverse correlations should be dominant [in the case of equality, when $\vec{h}(\vec{r}) = 0$, the transverse and longitudinal correlations are equal, i. e., $\langle S^x(\vec{r}')S^x(\vec{r}) \rangle = \langle S^x(\vec{r}')S^z(\vec{r}) \rangle$]. We will consider only the case of *nearest-neighbor interactions* and will use the formulas derived with a corridor Δ , since these yield the best bounds. (Our conclusions will be compared to those following without the corridor to point out the relative gains.) The basic equations, then, are (2.50) and the sets of coefficients (2.58)–(2.62) [or (2.46)–(2.48)].

In order to simplify the geometry we shall suppose that Ω fills the box Λ so that the bounding surfaces of Ω are plane. Similarly, we take Γ to be a rectangular parallelepiped of dimensions $\mathfrak{N}_x \times \mathfrak{N}_y \times \mathfrak{N}_z = \mathfrak{N}_x \mathfrak{N}_d$ for $d=1$ and $\mathfrak{N}_x \times \mathfrak{N}_y \times \mathfrak{N}_z = \mathfrak{N}_x \mathfrak{N}_y \mathfrak{N}_d$ for $d=2$ [see (3.1)], which implies

$$\begin{aligned} \mathfrak{N}(\Delta) &= 2\mathfrak{N}_y \mathfrak{N}_z (\nu - 1) \\ &= 2\mathfrak{N}_z (\mathfrak{N}_x + \mathfrak{N}_y + \nu - 2)(\nu - 1), \\ \mathfrak{N}(\Gamma) &= \mathfrak{N}_x \mathfrak{N}_y \mathfrak{N}_z, \quad d=1 \\ &= \mathfrak{N}_x \mathfrak{N}_y \mathfrak{N}_z, \quad d=2 \end{aligned} \quad (5.1)$$

for a corridor of width ν . Also, with this geometry we find from the definition (2.55) that

$$\begin{aligned} \mathfrak{N}_\Delta &= 2\mathfrak{N}_y \mathfrak{N}_z \nu, \quad d=1 \\ &= 2\mathfrak{N}_z [\mathfrak{N}_x + \mathfrak{N}_y + 2(\nu - 1)]\nu, \quad d=2. \end{aligned} \quad (5.2)$$

Furthermore, it is convenient to define the characteristic linear dimension of Γ in units of lattice spacings by

$$\begin{aligned} \mathfrak{N}_L &= \mathfrak{N}_x, \quad d=1 \\ &= (\mathfrak{N}_x \mathfrak{N}_y)^{1/2}, \quad d=2. \end{aligned} \quad (5.3)$$

We consider first the following case.

$$A. d=1$$

From (2.58) and (5.1)–(5.3) we have

$$a^2 \lambda = 2\mu_1 / \nu (\mathfrak{N}_L + 2\nu - 2), \quad (5.4)$$

where we recall that we are discussing only the case of zero external field. On setting $\kappa = 0$, we may combine (2.51) and (5.4) to give

$$X = 2\mu_1 \mathfrak{N}_y \mathfrak{N}_z / a^2 \nu [1 + 2(\nu - 1) / \mathfrak{N}_L]. \quad (5.5)$$

Now the optimization condition (4.22) with the definition (2.60) of q_1 implies that $X^* \propto T$. By (5.5) this means that as T is reduced the optimal corridor width ν^* increases as $1/T$ [compare with (I.4.13)]. Conversely, at high enough temperatures the optimization equation (4.22) would require $\nu^* < 1$,

which is impossible; in fact, the inequality should then be used simply in the “no-corridor” form $\nu = 1$. [Note that formulas (5.1)–(5.4) reduce correctly for this case.] For $\nu > 1$ the optimized inequality (4.23) can be written in the simple form

$$[\Psi_\Omega \{f | \Gamma\} / \bar{S}]^2 \leq [\mathfrak{N}_0 / \mathfrak{N}_L]^2, \quad d=1 \quad (5.6)$$

where the scale length (number of sites) \mathfrak{N}_0 is given by

$$\begin{aligned} \mathfrak{N}_0^{1/2} &= 4\sqrt{2} t (1 - \gamma^*)^{-1/2} (\mathfrak{N}_y \mathfrak{N}_z / \tau)^{1/2} + (S / \bar{S}^2) / 2\mathfrak{N}_y \mathfrak{N}_z \mathfrak{N}_L^{1/2}, \\ d=1, \quad \nu &= \nu^* > 1 \end{aligned} \quad (5.7)$$

for $\mathfrak{N}_L \gg 1$. Here we have introduced the reduced temperature variable

$$\tau = k_B T / J_{\Gamma \cup \Delta} \bar{S}^2, \quad (5.8)$$

in terms of which the bulk critical temperature corresponds to $\tau_c \simeq 4$ or 5. From (4.22) and (5.5) we note that the optimization condition ceases to have a meaningful solution for

$$\tau \gtrsim \mu_1 \mathfrak{N}_y \mathfrak{N}_z = \tau_0, \quad (5.9)$$

so that for reduced temperatures greater than τ_0 , optimum results are obtained with no corridor.

It is clear from (5.6) [and the definition (2.6), which shows that Ψ cannot exceed \bar{S}] that the inequality only has force when $\mathfrak{N}_L > \mathfrak{N}_0$. For $\tau \ll \tau_0$ (where the optimization analysis is valid), \mathfrak{N}_0 will be large so that $t \simeq 1$ and the second term of (5.7) may be neglected. Furthermore, from the optimization equation (4.22), the definitions (2.59)–(2.62), and (5.9) we have $\gamma^* \simeq 2\tau_0 / \tau \mathfrak{N}_L$. For large \mathfrak{N}_L we may neglect γ^* in (5.7). With these approximations we finally obtain [see (1.8)]

$$\mathfrak{N}_0 \simeq 32 \mathfrak{N}_y \mathfrak{N}_z / \tau, \quad (5.10)$$

so that at lower temperatures progressively larger subvolumes $\mathfrak{N}(\Gamma)$ must be considered to see the decay of order. For a linear chain of spins, $\mathfrak{N}_y = \mathfrak{N}_z = 1$, with constant exchange ($\mu_1 = 1$), we have $\tau_0 = 1$, and for $\tau \simeq \frac{1}{4}$ find $\mathfrak{N}_0 \simeq 128$. As the cross section $\mathfrak{N}_d = \mathfrak{N}_y \mathfrak{N}_z$ increases, the bound becomes weaker rapidly unless the temperature is increased proportionately. This behavior and the form of \mathfrak{N}_0 can be understood heuristically as follows. Consider (as in the Bose case) a fluctuation which “disorders” the subdomain Γ by inverting the directions of a group of ordered spins near the center of Γ relative to the direction of ordering outside Γ . Such a fluctuation will require an energy (or, more properly, free energy) corresponding at least to the formation of two Bloch walls each of thickness $\leq \frac{1}{2} \mathfrak{N}_L = \frac{1}{2} \mathfrak{N}_x$ and area \mathfrak{N}_d . The mean angle of twist between spins in successive lattice layers in these walls must be

$$\Delta \theta \simeq \pi / \frac{1}{2} \mathfrak{N}_x = 2\pi / \mathfrak{N}_L, \quad (5.11)$$

and the corresponding total Bloch wall energy is estimated simply by

$$\begin{aligned} \Delta E &\simeq 2\mathfrak{N}_d \left(\frac{1}{2}\mathfrak{N}_x\right) |J| \bar{S}^2 (1 - \cos \Delta\theta) \\ &\simeq \frac{1}{2}\mathfrak{N}_d \mathfrak{N}_x |J| \bar{S}^2 (\Delta\theta)^2. \end{aligned} \quad (5.12)$$

The ratio of this disordering energy to the mean thermal energy is just

$$\begin{aligned} \Delta E/k_B T &\simeq 2\pi^2 \mathfrak{N}_y \mathfrak{N}_z |J| \bar{S}^2 / k_B T \mathfrak{N}_L \\ &\simeq (2\pi^2 \mathfrak{N}_y \mathfrak{N}_z / \tau) / \mathfrak{N}_L. \end{aligned} \quad (5.13)$$

This is of precisely the same form as the ratio $\mathfrak{N}_0/\mathfrak{N}_L$ entering (5.6) [with use of (5.10)]. Even the coefficient $2\pi^2 \simeq 20$ is the correct order of magnitude; the argument thus tends to discourage further efforts to reduce this numerical constant.

When $\tau \gtrsim \tau_0$, we cannot use the result (5.6) with (5.7), which was based on the optimized inequality (4.23). Rather, we must set $\nu = 1$ in (5.1)–(5.5) (for no corridor), and study the general inequality (4.20) (which is valid even for long range forces with $\mu_2 \neq 1$). The final result may be written in the same form (5.6), but now with

$$\mathfrak{N}_0^{1/2} = \frac{8^{1/2} t (\tau + \mu_1 \mathfrak{N}_y \mathfrak{N}_z)}{\mu_1^{1/2} \tau} + \frac{\mu_1 (S/\bar{S}^2)}{\mathfrak{N}_L^{1/2} (\tau + \mu_1 \mathfrak{N}_y \mathfrak{N}_z)}, \quad (5.14)$$

where now

$$t^{-1} = (2/\pi) \tan^{-1} [\pi (\mu_2 \mathfrak{N}_L / 2\mu_1)^{1/2}] \quad (5.15)$$

in place of (4.24). For interesting values of \mathfrak{N}_L ($\gg 1$), we have t close to unity, and the second term in (5.14) can be dropped as before. With these approximations we obtain the general result

$$\mathfrak{N}_0 = 8(\mu_2/\mu_1) [1 + \mu_1 (\mathfrak{N}_y \mathfrak{N}_z / \tau)]^2, \quad d=1, \nu=1 \quad (5.16)$$

where we recall that $\mu_2 = \mu_1 = 1$ for nearest-neighbor interactions on a homogeneous lattice. The bound following from (5.6) with (5.16) is valid for all temperatures. Evidently at very high temperatures \mathfrak{N}_0 approaches a finite limit, namely, $\mathfrak{N}_0^\infty = 8$ (for $\mu_2 = \mu_1 = 1$). This result is a reflection of the discrete lattice structure and contrasts with the corresponding result for a Bose fluid where the thermal de Broglie wavelength Λ_T vanishes as $T \rightarrow \infty$, so that the corresponding bounds on the amplitude of the off-diagonal order become increasingly strong. In the vicinity of the bulk transition temperature $\tau \simeq 4$ the formula (5.16) gives $\mathfrak{N}_0 \simeq 12$ for a linear chain ($\mathfrak{N}_y = \mathfrak{N}_z = 1$). As T becomes small, however, (5.16) leads to values of \mathfrak{N}_0 increasing like $1/T^2$, whereas the optimal values from (5.10) ($\nu = \nu^*$) diverge only as $1/T$. As an explicit example, when $\tau = \frac{1}{8}$ and $\mathfrak{N}_y = \mathfrak{N}_z = 1$, we find $\mathfrak{N}_0 \simeq 200$ from (5.16), whereas (5.7) gives the better result $\mathfrak{N}_0 \simeq 128$. We may summarize the optimal low-temperature

bounds (for $\mu_1 = \mu_2 = 1$) by

$$[\Psi_\Omega \{f | \Gamma\} / \bar{S}]^2 \leq 4\sqrt{2} (\mathfrak{N}_y \mathfrak{N}_z / \tau \mathfrak{N}_L)^{1/2}, \quad d=1. \quad (5.17)$$

Lastly, in Fig. 2 we have plotted the bounds on the reduced order $[\Psi/\bar{S}]^2$ versus the length \mathfrak{N}_L on a logarithmic scale for various values of the reduced temperature τ [see (5.8)]. These bounds have been calculated from the full inequality (4.20) with optimal choice of the integer ν .

Finally, we turn to systems of finite thickness.

B. $d=2$

From (2.58), (5.1), and (5.2) we find

$$a^{2\lambda} = \frac{2\mu_1 \nu^{-1} [\mathfrak{N}_x + \mathfrak{N}_y + 2(\nu - 1)]}{\mathfrak{N}_x \mathfrak{N}_y + 2(\nu - 1)(\mathfrak{N}_x + \mathfrak{N}_y + \nu - 2)}. \quad (5.18)$$

It is clear from the basic inequality (4.31) or from its optimized form (4.36) that the inequality only takes effect when $\mathfrak{N}_L \gg 1$. In the circumstances the second term in the inequalities is quite negligible and the optimized result can be written

$$[\Psi_\Omega \{f | \Gamma\} / \bar{S}]^2 \leq 4\pi \mathfrak{N}_z / \tau (1 - \gamma^*) (\mathfrak{L} - \ln \mathfrak{L}), \quad (5.19)$$

where now from (4.35), (2.60), and (5.3) we have

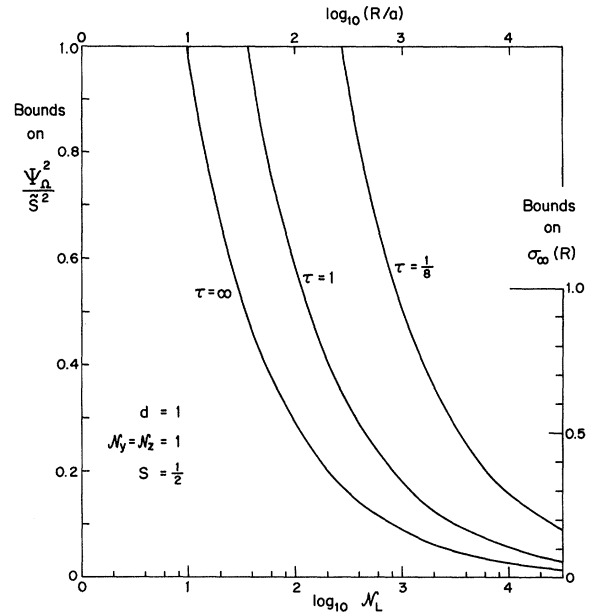

FIG. 2. Bounds on the order $[\Psi_\Omega \{f | \Gamma\} / \bar{S}]^2$ versus \mathfrak{N}_L for a linear chain of spins ($\mathfrak{N}_y = \mathfrak{N}_z = 1$, $S = \frac{1}{2}$) interacting with nearest-neighbor exchange. The curves have been obtained from the full inequality (4.20) optimized numerically with respect to ν for several values of the reduced temperature τ . The upper horizontal axis is a distance scale for interpreting the curves as bounds on $\sigma_\infty(\bar{R})/\bar{S}^2$ using (6.3) and (6.4). The right-hand vertical scale must then be used.

$$\mathcal{L} = \mathcal{L}(\Gamma) \simeq \ln[(\pi^2/2e\tau) \mathfrak{N}_x \mathfrak{N}_L^2], \quad (5.20)$$

in which the γ dependence of q_1 has been neglected. However, since γ^* will be shown to be proportional to \mathcal{L}^{-1} , the γ^* dependence exhibited in (5.19) cannot be ignored. To see this notice that the optimization equation (4.34) can be written with the aid of (5.1) and (5.18) as

$$\frac{\nu^*}{\mathfrak{N}_L} = \frac{\mu_1 \mathfrak{N}_x u}{\tau(\mathcal{L} - \ln \mathcal{L})} \left[1 + O\left(\frac{\nu^*}{\mathfrak{N}_L}\right) \right], \quad (5.21)$$

where the "shape factor"

$$u = u(\Gamma) = \frac{1}{2} [(\mathfrak{N}_x/\mathfrak{N}_Y)^{1/2} + (\mathfrak{N}_Y/\mathfrak{N}_x)^{1/2}] \quad (5.22)$$

is unity for a square domain ($\mathfrak{N}_x = \mathfrak{N}_Y = \mathfrak{N}_L$). From the definition of γ in (2.62) and the geometrical assumptions (5.1) and (5.2) it follows that

$$1 - \gamma^* \simeq 1 - c'/(\mathcal{L} - \ln \mathcal{L}), \quad (5.23)$$

with

$$c' = c'(\tau) = 4u^2 \mu_1 \mathfrak{N}_x / \tau. \quad (5.24)$$

Allowing for this dependence, (5.19) can be rewritten

$$[\Psi_\Omega \{f | \Gamma\} / \bar{S}]^2 \leq 2\pi \mathfrak{N}_x / \tau \ln[\mathfrak{N}_L / \mathfrak{N}_0(\Gamma)], \quad d=2, \quad (5.25)$$

where the scale length

$$\mathfrak{N}_0(\Gamma)^2 = (2e^{1+c'} \tau / \pi^2 \mathfrak{N}_x) \ln[(\pi^2 \mathfrak{N}_x / 2e^{1+c'} \tau) \mathfrak{N}_L^2], \quad d=2, \quad \nu = \nu^* \quad (5.26)$$

depends weakly on \mathfrak{N}_L .

Comparing with (5.19), we see that whenever the inequality has effect, we have $\mathfrak{N}_x / \tau(\mathcal{L} - \ln \mathcal{L} - c') < 1/4\pi \ll 1$, so that [assuming μ_1 , $u = O(1)$] we have from (5.21) $\nu^* \propto \mathfrak{N}_L / \ln \mathfrak{N}_L$. So ν^* will be much greater than unity, and the optimized inequality is valid and accurate in all cases of practical interest. [However, for *small* \mathfrak{N}_L one may have to set $\nu = 1$, 2, 3, etc., in the original, unoptimized inequality (4.31) for complete accuracy.]

It is instructive to see how the result (5.25) with (5.26) compares with that obtained with no corridor ($\nu = 1$). From (4.31), (4.32), and (5.3) we find, as above, that for $\mathfrak{N}_L \gg 1$, we have

$$[\Psi_\Omega \{f | \Gamma\} / \bar{S}]^2 \leq \Phi^2 / \ln(\mathfrak{N}_L / \mathfrak{N}_0), \quad d=2 \quad (5.27)$$

where, now

$$\mathfrak{N}_0 = 4\mu_1 / \pi^2 \mu_2, \quad d=2, \quad \nu=1 \quad (5.28)$$

and

$$\Phi^2 = 4\pi \mu_2 \mathfrak{N}_x \tau^{-1} [1 + (\tau/2u\mathfrak{N}_x N_L)]. \quad (5.29)$$

When the bound is of practical interest, the term in square brackets is close to unity. Then in the nearest-neighbor case ($\mu_2 = 1$) the inequality (5.27)

has precisely the form of (5.25), except, first, the optimized coefficient is 2π in place of 4π and, second, the optimized scale length $\mathfrak{N}_0(\Gamma) \sim \ln \mathfrak{N}_L$ rather than being fixed [as in (5.28)]. These two effects act in opposite directions but the first strengthens the inequality far more than the second weakens it.

Numerically even the optimized bound (5.25) is rather weak. The most favorable case is clearly that of a single layer, $\mathfrak{N}_x = 1$. If $\tau \approx 3$, which corresponds to a typical two-dimensional ordering temperature, the bound begins to take effect when \mathfrak{N}_L exceeds about 28. [The weaker bound (5.27) with (5.28) and (5.29) only comes into play when $\mathfrak{N}_L \gtrsim 33$.] However, to establish, say, $\Psi^2 \leq \frac{1}{4} \bar{S}^2$, one must take $\mathfrak{N}_L \geq 2 \times 10^4$. More generally, the best bounds to $(\Psi/\bar{S})^2$ are plotted in Fig. 3 versus $\mathfrak{N}_L (= \mathfrak{N}_x = \mathfrak{N}_Y)$ for various values of τ (for the uniform nearest-neighbor situation where $\mu_1 = \mu_2 = 1$). Evidently, when $\tau = 4$, one must go to the "macroscopic" length $\mathfrak{N}_L \approx 10^9$ in order to show that $\Psi^2 \leq \frac{1}{10} \bar{S}^2$. The bounds improve as T increases but weaken correspondingly as the thickness increases.

The heuristic Bloch-wall argument presented in the $d=1$ case is easily extended to the two-dimensional situation. One sees that the ratio \mathfrak{N}_x/τ appearing in (5.25) and elsewhere is essentially

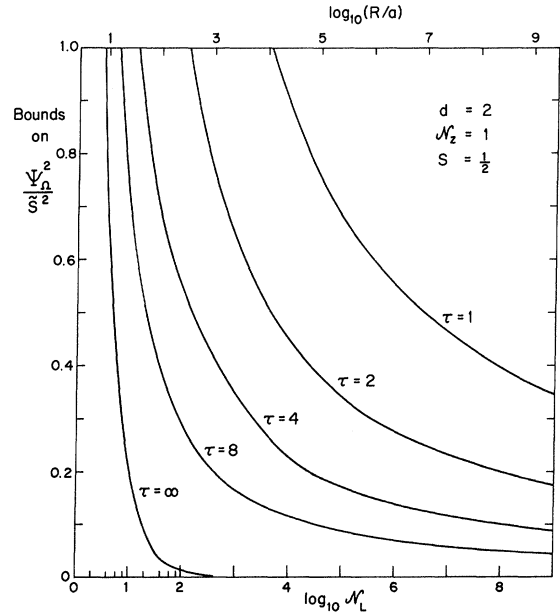

FIG. 3. Bounds on the order $[\Psi_\Omega \{f | \Gamma\} / \bar{S}]^2$ versus \mathfrak{N}_L for a planar lattice of spins ($\mathfrak{N}_x = 1$, $S = \frac{1}{2}$) interacting with nearest-neighbor exchange. The curves have been obtained from the full inequality (4.31) optimized numerically with respect to ν for several values of the reduced temperature τ . The upper horizontal axis is a distance scale for interpreting the curves as bounds on $\sigma_\infty(\vec{R})/\bar{S}^2$ using (6.3), (6.5), and (6.6). The vertical scale must then be multiplied by 16.

the ratio of the incremental (wall) free energy needed to invert $\mathfrak{X}_x \mathfrak{X}_y \mathfrak{X}_z$ spins to the mean thermal energy. The argument does not, however, yield the logarithmic dependence of the bound and will not be presented in detail.

VI. POINT-TO-POINT CORRELATIONS

The bounds discussed above refer to average (or sums) of the correlation function $\sigma(\vec{r}, \vec{r}')$ over a domain Γ . If this correlation function is known to be non-negative, then more detailed results can be obtained. In fact, the positivity of the spin-spin correlation functions $\langle S^+(\vec{r}')S^-(\vec{r}) \rangle$ has been established^{19,20} when all the interactions $J_\alpha(\vec{r}, \vec{r}')$ are non-negative. Then by following the line of argument given in Sec. V of I we can quite easily prove that the "projected" correlation function²¹

$$\bar{\sigma}_\infty(\vec{R}_\parallel) = \mathfrak{X}_d^{-2} \sum_{\vec{r}_\perp} \sum_{\vec{r}'_\perp} \langle S^+(\vec{r}_\parallel + \vec{R}_\parallel, \vec{r}'_\perp) S^-(\vec{r}_\parallel, \vec{r}'_\perp) \rangle \quad (6.1)$$

"decreases on the average" at least as fast as $1/|\vec{R}_\parallel|^{1/2}$ for $d=1$, and as $1/\ln(|\vec{R}_\parallel|/r_0)$ for $d=2$ in the sense that

$$\sum_{|\vec{R}_\parallel| < R} \bar{\sigma}_\infty(\vec{R}_\parallel) \leq B_1 R^{1/2}, \quad d=1$$

$$\leq B_2 R^2 / \ln(R/r_0), \quad d=2. \quad (6.2)$$

The amplitudes B_1 and B_2 depend on the temperature, etc., and, as explained in Sec. V above in connection with the scale number, we have $r_0 = r_0(R) \propto \ln R$.

More specifically, if it is also known that $\bar{\sigma}_\infty(\vec{R}_\parallel)$ decreases *monotonically* with $|\vec{R}_\parallel|$ for sufficiently large arguments, one can prove (see Sec. V of I) that

$$\bar{\sigma}_\infty(R)/\bar{S}^2 \leq A_1/(R/a)^{1/2}, \quad d=1$$

$$\leq A_2/\ln(2\sqrt{2}R/r_0), \quad d=2 \quad (6.3)$$

as $R \rightarrow \infty$. For the uniform nearest-neighbor chain ($\mathfrak{X}_y = \mathfrak{X}_z = 1$) one finds from the results of Sec. V that

$$A_1 = 6\sqrt{3}/\tau^{1/2}, \quad d=1 \quad (6.4)$$

in the regime where the analytic optimization provides a good approximation. Similarly, for the single-layer lattice ($\mathfrak{X}_z = 1$) one finds

$$A_2 = 32\pi/\tau \quad (6.5)$$

and

$$r_0/a = \{ (2e^{1+c'}\tau/\pi^2) \ln[(\pi^2/2e\tau)(2\sqrt{2}R)^2] \}^{1/2} \quad (6.6)$$

also in the region where the optimization is valid. More general expressions for A_1 , A_2 , and r_0 follow from the general inequalities (4.20) and (4.31). Notice that the curves of Fig. 2 (for $d=1$) are bounds on²¹ $\sigma_\infty(\vec{R})/\bar{S}^2$ if the abscissa is interpreted as $\log_{10}(R/a)$ and [from (6.4) and (5.10)] the $(\Psi_0/\bar{S})^2$ scale is multiplied by 1.837. It should be recalled that Fig. 2 is drawn for $\mathfrak{X}_y = \mathfrak{X}_z = 1$, $S = \frac{1}{2}$. The correlation function $\sigma_\infty(\vec{R})/\bar{S}^2$ is bounded when $d=2$ ($\mathfrak{X}_z = 1$, $S = \frac{1}{2}$) by curves of similar shape to those shown in Fig. 3 [with reinterpretation of the abscissa as $\log_{10}(2\sqrt{2}R)$ and multiplication of the vertical scale by 16]. Finally, it should be noted that although the monotonic decay of $\bar{\sigma}_\infty(\vec{R}_\parallel)$ [or of $\sigma(\vec{r}, \vec{r}')$] is quite plausible, it has *not* been established (nor does it seem easy to do so).

ACKNOWLEDGMENTS

We are grateful for the support of the Advanced Research Projects Agency through the Materials Science Center at Cornell University, and of the National Science Foundation.

*Presently on leave at the Department of Applied Physics, Hansen Laboratories, Stanford University, Stanford, Calif.

†Presently at K. F. A. Jülich, Institut für Festkörperforschung, 517 Jülich, Germany; permanent address: Department of Physics, University of Pittsburgh, Pittsburgh, Pa.

¹D. Jasnow and M. E. Fisher, preceding paper, Phys. Rev. B 2, 895 (1970). The reader is referred to the Introduction for detailed references to previous work.

²A preliminary account has been presented by the authors in Phys. Rev. Letters 23, 286 (1969).

³G. V. Chester, M. E. Fisher, and N. D. Mermin, Phys. Rev. 185, 760 (1969).

⁴Several different types of long-range order are discussed in Sec. II of I.

⁵N. N. Bogoliubov, Phys. Abhandl. S. U. 6, 113 (1962).

⁶H. E. Stanley and T. A. Kaplan, Phys. Rev. Letters 17, 913 (1966). See also Ref. 3.

⁷See Sec. III of I for the discussion of the corridor in the Bose particle case. There the introduction of the corridor was essential and not just devised for an im-

provement of numerical results.

⁸D. Ruelle, *Statistical Mechanics: Rigorous Results* (Benjamin, New York, 1969); M. E. Fisher, Arch. Ratl. Mech. Anal. 17, 337 (1964).

⁹See the discussion in Sec. II of I encompassing Eqs. (I 2.15)-(I 2.21) and also T. D. Schultz, D. C. Mattis, and E. H. Lieb, Rev. Mod. Phys. 36, 856 (1964).

¹⁰N. D. Mermin and H. Wagner, Phys. Rev. Letters 17, 1133 (1968).

¹¹M. J. Lighthill, *Fourier Analysis and Generalized Functions* (Cambridge U. P., Cambridge, England, 1958), Chap. 3, Table I.

¹²G. S. Joyce, J. Phys. C 2, 1531 (1969).

¹³Recall that $\mu_2 = 1$ for the case of nearest-neighbor interactions.

¹⁴With somewhat greater generality we could simply assume that both μ_2 and μ_1 are uniformly bounded as $\mathfrak{X}(\Gamma) \rightarrow \infty$. The existence of μ_2 , the second moment of $J(\vec{R}_\parallel)$, might be expected to *imply* the existence of μ_1 , which is effectively a *first* moment. This conclusion is not immediate, however, since the average surface interactions $J^\beta(\vec{R}_\parallel)$ ($\beta = X, Y$) entering the definition of μ_1

[see (3.19)] are *not* the same as the average bulk interaction $J_{\Gamma}(\vec{R}_{||})$.

¹⁵The optimized inequality (4.23) is approximately correct when ν^* determined by (4.22) is near an integer. It is not a good approximation at high temperatures when the solution of (4.22) becomes $\nu^* < 1$. This indicates that $\nu = 1$ (no corridor) is then optimal. See Sec. V for numerical examples.

¹⁶Strictly speaking, we have again established this result only for the cases in which the monotonic decreasing bound $J_0(|\vec{R}_{||}|)$ exists, since it is not immediately obvious that the nonintegrability of $[\hat{J}_{\Gamma}(\vec{0}) - \hat{J}_{\Gamma}(\vec{k}_{||})]^{-1}$ implies that $\mu_1(\Gamma)/\mathfrak{N}(\Gamma) \rightarrow 0$ as $\mathfrak{N}(\Gamma) \rightarrow \infty$. It is not worthwhile, however, to worry about possible pathological cases in this connection.

¹⁷T. Matsubara and H. Matsuda, *Progr. Theoret. Phys.* (Kyoto) **16**, 569 (1956); R. Whitlock and P. Zil-

sel, *Phys. Rev.* **131**, 2409 (1963); M. E. Fisher, *Rept. Progr. Phys.* **30**, 615 (1967).

¹⁸As stated previously, the absence of long-range order is established even when transverse fields are present in the corridor Δ . However, to simplify the numerical analysis they are assumed to vanish.

¹⁹J. Ginibre in Lectures given at the Cargèse Summer School in Statistical Mechanics, 1969 (unpublished); C. A. Hurst and S. Sherman, *Phys. Rev. Letters* **22**, 1357 (1969); G. Gallavotti (unpublished).

²⁰The bounds obtained have been for subdomains Γ which were "slices" as shown in Fig. 1. We may obtain bounds for a general subdomain Θ in the case $f(\vec{r}) \equiv 1$ once the non-negativity of $\sigma(\vec{r}, \vec{r}')$ has been established. It then follows that $\Psi_{\Omega}\{1|\Theta\} \leq \Psi_{\Omega}\{1|\Gamma\}$ provided $\Theta \subset \Gamma$.

²¹Notice that $\bar{\sigma}_{\infty}(\vec{r}, \vec{r}') = \sigma_{\infty}(\vec{r}, \vec{r}')$ when $\mathfrak{N}_y = \mathfrak{N}_z = 1$ ($d = 1$) and when $\mathfrak{N}_z = 1$ ($d = 2$).

Specific Heat of Nickel near the Curie Temperature*

D. L. Connelly, J. S. Loomis, and D. E. Mapother

*Department of Physics and Materials Research Laboratory,
University of Illinois, Urbana, Illinois 61801*

(Received 6 August 1970)

Using an ac calorimetric method, the specific heat $C_p(T)$ of pure single-crystalline Ni has been measured over a temperature range of 100 K centered at the Curie point (~ 631 K). The experimental method permits continuous observation of C_p vs T with a temperature resolution of ~ 0.01 K using very small specimens (~ 7.8 mg). Special attention has been devoted to the determination of the analytical form of the magnetic contribution to $C_p(T)$. The effect of applied fields up to 240 Oe has also been studied. At zero field, the data fit a standard power-law expression over the range $-3.2 \leq \log_{10} |(T - T_c)/T_c| \leq -1.6$, with exponents $\alpha = \alpha' = -0.10 \pm 0.03$. The data obtained with applied field follow the scaling relations calculated by Griffiths from the magnetic equation of state. The observed rounding of the specific-heat curve at its maximum is discussed and some experimental factors which influence the degree of the observed rounding are described.

I. INTRODUCTION

This paper reports an experimental study of the temperature dependence of the specific heat $C_p(T)$ for Ni near its Curie point ($T_c \approx 631$ K). The measurements are made using an ac calorimetric technique which permits direct observation of $C_p(T)$ as a continuous function of T (with a temperature resolution of about 10^{-2} K) on small specimens of mass about 10 mg. These experimental advantages permit unusually precise examination of $C_p(T)$ near the singularity at T_c using very small specimens of relatively high crystalline perfection.

The ac calorimetric method used here is an elaboration of a basic technique originally developed and described independently by Kraftmakher¹ and by Sullivan and Seidel.² A previous account outlining the essential details of the present method and giving some preliminary data for Ni was published earlier.³ The results reported here are be-

lieved to give a more detailed picture of the form of the singularity in $C_p(T)$ for Ni than any of the previously reported investigations. Preliminary results on the effect of an applied magnetic field and some of the physical factors which affect the shape of the singularity are also described.

II. EXPERIMENTAL METHOD

A. Technique

The same technical principles described earlier³ are used here, but several refinements have been made. The principal changes are intended to (a) increase the sensitivity and precision of the temperature measurements and (b) improve the quality of the measured Ni specimens.

The Ni specimens are single-crystal chips ($3 \times 3 \times 0.1$ mm) lightly supported in the center of a massive copper assembly which occupies the center of a furnace. The dominant thermal contact between the specimen and the copper surroundings is