

± 0.001 eV. The M_0 -point contribution to the resulting line shape is about 25%.

We feel that the good agreement (Fig. 2) between the experimental points and the curve calculated on the basis of the metamorphism of critical points provides strong evidence that the exciton model describes quite well (also in a bidimensional crystal)

the effect of the Coulomb interaction upon the direct interband transitions above the fundamental edge. Further work is now in progress to show the presence of such an effect in GaSe.

The authors are very grateful to P. Corradini and A. Verdecchia for helpful assistance in solving many computing problems.

¹M. Cardona, *Modulation Spectroscopy* (Academic, New York, 1969).

²B. Velicky and J. Sak, *Phys. Status Solidi* **16**, 147 (1966); Y. Toyozawa, H. Inoue, T. Inui, M. Okazaki, and E. Hanamura, *J. Phys. Soc. Japan* **22**, 1337 (1967).

³J. E. Rowe and D. E. Aspnes, *Phys. Rev. Letters* **25**, 162 (1970).

⁴S. Antoci, E. Reguzzoni, and G. Samoggia, *Phys. Rev. Letters* **24**, 1304 (1970).

⁵D. D. Sell and E. O. Kane, *Phys. Rev.* **185**, 1103 (1969).

⁶K. L. Shaklee, J. E. Rowe, and M. Cardona, *Phys. Rev.* **174**, 828 (1968).

⁷G. Harbeke, *Phys. Status Solidi* **27**, 9 (1968).

⁸B. Batz, *Solid State Comm.* **4**, 241 (1966); A. Balzarotti and M. Grandolfo, *ibid.* **6**, 815 (1968); E. Matatagui, A. G. Thomson, and M. Cardona, *Phys.*

Rev. **176**, 950 (1968).

⁹F. Bassani and G. Pastori Parravicini, *Nuovo Cimento* **50B**, 95 (1967).

¹⁰H. Kamimura and K. Nakao, *J. Phys. Soc. Japan* **24**, 1313 (1968).

¹¹D. L. Greenaway, G. Harbeke, F. Bassani, and E. Tosatti, *Phys. Rev.* **178**, 1340 (1969).

¹²F. Bassani, D. L. Greenaway, and G. Fischer, in *Proceedings of the Fourth International Conference on the Physics of Semiconductors, Paris* (Dunod, Paris, 1966), p. 51.

¹³M. Grandolfo, F. Somma, and P. Vecchia (to be published).

¹⁴A. Balzarotti and M. Grandolfo, *Phys. Rev. Letters* **20**, 9 (1968).

¹⁵B. O. Seraphin and N. Bottka, *Phys. Rev.* **145**, 632 (1966).

Dynamical Theory of the Large Polaron: Fock Approximation

D. Matz and B. C. Burkey

Research Laboratories, Eastman Kodak Company, Rochester, New York 14650

(Received 18 November 1970)

A Green's-function equation-of-motion analysis of the large polaron is presented. Existing theories for the ground-state energy and effective mass are obtained from a nondiagonal form of the Fock approximation to the electron self-energy. A connection between the usual canonical transformation techniques and the Green's-function approach is given explicitly. The effects of vertex corrections and translational invariance are examined in the context of these results.

I. INTRODUCTION

The problem of the large polaron has received considerable attention in the past.¹⁻⁴ There remain, however, a number of unanswered theoretical questions which arise when one attempts to make predictions that can be verified experimentally. For a small electron-phonon coupling constant α , the polaron ground-state energy can be obtained from perturbation theory,^{1,3-6} and has the form

$$E_0 = -\alpha - 0.0159\alpha^2 - O(\alpha^3).$$

For large α , the ground-state energy has the form¹⁻⁴

$$E_0 = -a_0\alpha^2 - a_1\alpha^0 - O(\alpha^{-2}).$$

Thus, as indicated by Larsen,⁷ polaron perturbation theory must have a finite radius of convergence. This implies a critical coupling constant α_c such

that for $\alpha > \alpha_c$ the polaron spectrum develops internal structure. The experimental verification of the internal structure would be facilitated by a theory which predicts α_c , the internal-energy spectrum, and the lifetimes of the states.⁸ A Green's-function equation-of-motion approach to the polaron problem should be appropriate because of its ability to handle dynamic effects and because it permits a systematic accounting of electron-phonon correlations by the use of Feynman graphs. Such a theory does not exist. On the other hand, existing polaron theories cannot be easily applied to these questions, partly because of mathematical complexities^{9,10} and partly because of inherent limitations.^{8,11-18} For example, Feynman's theory predicts $\alpha_c = 0$. The theories of Pekar¹¹ and Bogoliubov and Tiablikov¹² (referred to as PBT and reviewed by Allcock¹³) are adiabatic theories and therefore

valid only for large α . The variational theories of Höhler,¹⁴ Tiablikov,¹⁵ and Buimistrov and Pekar¹⁷ do not yield lifetimes or excited states. Furthermore, the relationship of these theories, both to each other and to a diagrammatic analysis, is not always clear.

Translational invariance is another important aspect of the polaron problem for large α . The Fröhlich Hamiltonian commutes with the total-crystal-momentum operator.⁴ This fact implies that the total crystal momentum is conserved, and that the polaron eigenfunctions must be simultaneously eigenstates of the total crystal momentum and the Fröhlich Hamiltonian. This condition has proved difficult to apply rigorously in the strong-coupling theories mentioned above.

The purpose of this paper is to present a theory of the polaron which is based on Green's function equation of motion, with emphasis on the strong-coupling limit. The objective of this paper is limited to establishing the origin of previous strong-coupling theories in terms of a selective summation of infinite subsets of Feynman diagrams. An attempt is made to identify and assess the relative importance of the Fock and vertex parts of the polaron self-energy in these theories and to investigate the question of translational invariance of the polaron and the critical-coupling constant α_c . The Green's-function theory presented here represents a different approach from the Green's-function theories of Tiablikov¹⁹ and Puff and Whitfield.²⁰ These authors use a translationally noninvariant many-electron Green's function calculated within the Hartree approximation, and then find the one-electron limit. This results in an artificial dependence of the ground-state energy on the Fermi level, which should be avoided because the polaron is a one-electron problem. Furthermore, as Puff and Whitfield point out,²⁰ the Hartree approximation should not yield a contribution to the self-energy if only one electron interacts with the phonon field. As will be seen later, the Hartree contribution never appears in a systematic expansion of the electron self-energy in terms of exact one-electron retarded Green's functions, which are the appropriate propagators for this problem.^{3,5,20} Porsch²¹ has recently developed a finite-temperature polaron theory which is based on employing successively the shifted harmonic-oscillator canonical transformation and a Green's-function equation of motion. The introduction of the Green's function, however, is used merely as a device to generalize the theory of Gross¹⁶ to low temperatures. At zero temperature the Green's-function equations of Porsch are redundant, and his approach is equivalent to that of Gross,¹⁶ and thus, no proper identification with regard to a diagrammatic analysis is possible.

It is clear that a polaron strong-coupling theory

must employ only exact electron propagators, since the zeroth-order description of strong coupling cannot result from using free-electron propagators or a perturbation expansion in terms of free-electron propagators. Therefore, the theory can be formulated only in terms of renormalized Fock and vertex diagrams of the irreducible self-energy.

Some of the results obtained from this Green's-function approach are as follows: (i) The usual strong-coupling energy is obtained from the non-diagonal Fock approximation to the polaron self-energy, i. e., by purposely ignoring total-crystal-momentum conservation. (ii) An explicit correspondence of the PBT and Feynman theories with the Green's-function theory is established, thus demonstrating that these theories are not based on the Hartree approximation as had been thought.^{4,19,20} (iii) The Fock approximation can be extended to weak coupling, yielding a critical α of about 6, as has also been reported elsewhere.^{6,9,15} (iv) The usual strong-coupling masses are obtained after translational invariance is taken into account. (v) The vertex terms are estimated to contribute to the constant term in the polaron self-energy. However, a question arises concerning the convergence of vertex corrections treated by perturbation theory.

Only the ground-state energy is calculated, although expressions for excited-state energies and associated lifetimes can also be obtained. The present calculations are restricted to zero temperature. The integral equation for the electron Green's function is derived in Sec. II. The connection between the Fock approximation and the Hamiltonian formalism is established in Sec. III. Translational invariance, the effective mass, and the vertex corrections to the self-energy are discussed in Sec. IV. Some final considerations are presented in Sec. V.

II. GREEN'S-FUNCTION EQUATIONS OF MOTION

The Fröhlich Hamiltonian, expressed in dimensionless form, is^{1,5,20}

$$H = \sum_{\mathbf{p}} p^2 c_{\mathbf{p}}^{\dagger} c_{\mathbf{p}} + \sum_{\mathbf{k}} a_{\mathbf{k}}^{\dagger} a_{\mathbf{k}} + \sum_{\mathbf{k}} (V_{\mathbf{k}} \rho_{\mathbf{k}} a_{\mathbf{k}} + V_{\mathbf{k}}^{\dagger} \rho_{-\mathbf{k}} a_{\mathbf{k}}^{\dagger}), \quad (1)$$

where $\rho_{\mathbf{k}} = \sum_{\mathbf{q}} c_{\mathbf{k}+\mathbf{q}}^{\dagger} c_{\mathbf{q}}$; $a_{\mathbf{k}}^{\dagger}$ and $a_{\mathbf{k}}$ are the phonon creation and annihilation operators; $c_{\mathbf{p}}^{\dagger}$ and $c_{\mathbf{p}}$ are the electron creation and annihilation operators;

$$V_{\mathbf{k}} = -i(4\pi\alpha r_0^3/\Omega)^{1/2} k^{-1},$$

where $r_0 = (\hbar/2m\bar{\omega})^{1/2}$, $\bar{\omega}$ being the phonon frequency and m the band mass, and Ω is the volume. The electron-phonon coupling constant is

$$\alpha = (e^2/2r_0\hbar\bar{\omega})(\epsilon_{\infty}^{-1} - \epsilon_0^{-1}).$$

The total momentum operator

$$\hat{P} = \sum_{\vec{p}} \vec{p} c_{\vec{p}}^{\dagger} c_{\vec{p}} + \sum_{\vec{k}} \vec{k} a_{\vec{k}}^{\dagger} a_{\vec{k}} \quad (2)$$

commutes with the Hamiltonian, i. e.,

$$[H, \hat{P}] = 0. \quad (3)$$

The zero-temperature electron Green's function, in momentum space, is given by^{5,20}

$$G(\vec{p}, \vec{p}'; \tau) = \langle 00 | T c_{\vec{p}}^{\dagger}(t) c_{\vec{p}'}(t') | 00 \rangle, \quad (4)$$

where $\tau = (t - t')$, T is the time-ordering symbol, and $|00\rangle$ is the electron-phonon vacuum state. In the low-density limit, the advanced Green's function vanishes, and $G = G^>$.²⁰ In frequency space,

$$G(\vec{p}, \vec{p}'; Z) = \langle 00 | c_{\vec{p}} [1/(Z - H)] c_{\vec{p}'}^{\dagger} | 00 \rangle, \quad (5)$$

where Z is a complex frequency. Equation (5) defines the expectation value of the resolvent operator in second quantized form, which is independent of the Fermi level, and Eq. (5) is thus the starting point of the present theory.

The derivation of the equations of motion for the Green's functions is accomplished by the inverse-operator expansion²²

$$\frac{1}{Z - H_0 - H_{\text{int}}} = \frac{1}{Z - H_0} + \frac{1}{Z - H_0} H_{\text{int}} \frac{1}{Z - H_0 - H_{\text{int}}}, \quad (6)$$

where H_{int} is the interaction term in the Fröhlich Hamiltonian. Dynamical approximations are then generated by the use of the identity

$$a_{\vec{k}} \frac{1}{Z - H} = \frac{1}{Z - H - 1} a_{\vec{k}} + \frac{1}{Z - H - 1} [a_{\vec{k}}, H_{\text{int}}] \frac{1}{Z - H} \quad (7)$$

which is readily derived from the commutator of H and $a_{\vec{k}}$, together with the identity operator

$$I = \left(\sum_{\vec{p}} c_{\vec{p}}^{\dagger} | 0 \rangle \langle 0 | c_{\vec{p}} \right) \sum_{n=0}^{\infty} P_n \quad (8)$$

which is inserted between products of resolvents in Eq. (6). Here

$$P_n = \frac{1}{n!} \sum_{\vec{k}_1 \dots \vec{k}_n} a_{\vec{k}_1}^{\dagger} a_{\vec{k}_2}^{\dagger} \dots a_{\vec{k}_n}^{\dagger} | 0 \rangle \langle 0 | a_{\vec{k}_1} a_{\vec{k}_2} \dots a_{\vec{k}_n}, \quad (9)$$

$$P_0 | 0 \rangle = | 0 \rangle$$

and P_n is a projection operator which projects out the n -phonon space.

Equation (6) yields the following equation for the Green's function:

$$G_0^{-1}(\vec{p}, Z) G(\vec{p}, \vec{p}'; Z) = \delta_{\vec{p}, \vec{p}'} + \sum_{\vec{k}} V_{\vec{k}} \langle 00 | c_{\vec{p}-\vec{k}} a_{\vec{k}} [1/(Z - H)] c_{\vec{p}}^{\dagger} | 00 \rangle, \quad (10)$$

where $G_0(\vec{p}, Z) = (Z - p^2)^{-1}$ is the free-electron propagator. Equation (10) is the first in a hierarchy of equations relating successively higher-order

Green's functions. A termination of these equations at various levels leads to the usual Tamm-Dancoff theories.^{1,23} These theories, however, do not yield a strong-coupling limit, at least within the tractable two-phonon cutoff, and therefore will not be pursued here (see Appendix A).

Now, by a repeated application of Eqs. (7)–(9), Eq. (10) becomes

$$G_0^{-1}(\vec{p}, Z) G(\vec{p}, \vec{p}'; Z) = \delta_{\vec{p}, \vec{p}'} + \sum_{\vec{p}_1} \Sigma(\vec{p}, \vec{p}_1; Z) G(\vec{p}_1, \vec{p}'; Z), \quad (11)$$

where

$$\Sigma(\vec{p}, \vec{p}_1; Z) = \sum_{\vec{k}} |V_{\vec{k}}|^2 G(\vec{p} - \vec{k}, \vec{p}_1 - \vec{k}; Z - 1) + \sum_{\vec{k}_1, \vec{p}_2, \vec{p}_3} |V_{\vec{k}_1}|^2 |V_{\vec{k}_2}|^2 G(\vec{p} - \vec{k}_1, \vec{p}_2 - \vec{k}_1; Z - 1) \times G(\vec{p}_2, \vec{p}_3 - \vec{k}_1; Z - 2) G(\vec{p}_3, \vec{p}_1 - \vec{k}_1; Z - 1) + \dots \quad (12)$$

is the polaron self-energy expressed in terms of exact propagators G . The self-energy given by Eq. (12) is the nondiagonal version of the conventional diagonal self-energy, which can be depicted diagrammatically in terms of the usual set of all topologically distinct, irreducible, and compact Feynman graphs.²⁴

Translational invariance, as expressed by Eq. (3), has been ignored to this point. If it is taken into account, then Eq. (11) assumes the usual factorized Dyson form²⁴

$$G^{-1}(\vec{P}, Z) = G_0(\vec{P}, Z) - \Sigma(\vec{P}, Z). \quad (13)$$

Here \vec{P} is now the total polaron crystal momentum, and is treated as a parameter. The self-energy in Eq. (13) has been evaluated only in fourth-order perturbation theory,¹ and approximately within the (diagonal) Fock approximation.^{20,25} A strong-coupling limit has not been obtained. It is assumed that vertex corrections, i. e., Feynman graphs with crossing phonon-propagator lines, are important,^{1,20} but it has not proved possible to deal with them.^{5,20,26}

Since it is the purpose here to show the origin of other theories, in terms of nondiagonal Green's functions, no attempts at solving Eq. (13) will be made. Rather, it will now be shown how one obtains the strong-coupling limit from Eq. (11), in which translational invariance is ignored (see, however, Sec. V).

First, Eq. (12) is approximated by using for $\Sigma(\vec{p}, \vec{p}_1; Z)$ only the first term on the right-hand side. Then Eq. (11) becomes

$$(Z - p^2) G(\vec{p}, \vec{p}'; Z) = \delta_{\vec{p}, \vec{p}'} + \sum_{\vec{k}, \vec{p}_1} |V_{\vec{k}}|^2 G(\vec{p} - \vec{k}, \vec{p}_1 - \vec{k}, Z - 1) G(\vec{p}_1, \vec{p}'; Z). \quad (14)$$

This equation, when iterated, generates all Feynman graphs with noncrossing phonon-propagator lines, i. e., the Fock approximation. In fact, the iterated version of Eq. (14) can be resummed in the diagonal form of Eq. (13) with the self-energy given by the usual Fock expression

$$\Sigma_F(\vec{p}, Z) = \sum_{\vec{k}} |V_k|^2 G(\vec{p} - \vec{k}, Z - 1).$$

This, it is believed, cannot give the strong-coupling limit, since G is now diagonal in contrast to G given by Eq. (14). Thus, although Eq. (14) is translationally noninvariant and therefore offers the possibility of localized solutions, it yields a translational invariant (i. e., electron momentum is conserved) solution if it is solved by iteration. This point will be elucidated later (see Sec. V).

For now, Eq. (14) will be solved by retaining the nondiagonality of G . Suppose that $G(\vec{p}, \vec{p}'; Z)$ can be expanded in a complete set of orthonormal func-

tions

$$G(\vec{p}, \vec{p}'; Z) = \sum_n \frac{\psi_n^*(\vec{p}) \psi_n(\vec{p}')}{Z - E_n} \quad (15)$$

such that

$$\begin{aligned} \sum_n \psi_n^*(\vec{p}) \psi_n(\vec{p}') &= \delta_{\vec{p}, \vec{p}'}, \\ \sum_{\vec{p}} \psi_n^*(\vec{p}) \psi_{n'}(\vec{p}) &= \delta_{n, n'}. \end{aligned} \quad (16)$$

Here, the E_n are then the poles of G , which could be either discrete or continuous. The lowest energy is obtained by setting $Z = E_0 + i\delta$, where δ is infinitesimally small. Then note that

$$\lim_{\delta \rightarrow 0} i\delta G(\vec{p}, \vec{p}'; Z = E_0 + i\delta) = \psi_0^*(\vec{p}) \psi_0(\vec{p}'). \quad (17)$$

If one substitutes Eq. (15) into Eq. (14), sets $Z = E_0 + i\delta$, and takes the limit of $\delta \rightarrow 0$, one obtains an equation for ψ_0 and E_0

$$(E_0 - p^2)\psi_0(\vec{p}) = - \sum_{\vec{k}, \vec{p}_1} |V_k|^2 \psi_0(\vec{p} - \vec{k}) \psi_0^*(\vec{p}_1 - \vec{k}) \psi_0(\vec{p}_1) - \text{P. V.} \sum_{m \neq 0} \sum_{\vec{k}, \vec{p}_1} |V_k|^2 \frac{\psi_m(\vec{p} - \vec{k}) \psi_m^*(\vec{p}_1 - \vec{k}) \psi_0(\vec{p}_1)}{E_m - E_0 + 1}, \quad (18)$$

where P. V. means principal value. To obtain Eq. (18), Eqs. (17) and (16) have been used. Equation (18) can also be obtained by Fourier-transforming Eq. (14) to time variables and taking the limit of infinite times, thereby ensuring that the electron-phonon interaction is at full value and that the polaron is in its ground state.^{3,9} There are several points to be noted about Eq. (18). (a) One needs a complete spectrum in order to obtain the solution for the ground-state energy. (b) In strong coupling, assuming $E_m - E_0 \propto \alpha^2$, then in the adiabatic limit one can neglect the P. V. term and obtain an equation similar to that of Pekar which describes the electron motion in a self-induced polarization potential.^{1,3,4,13,14,20} There is, however, no factor of 2 here in the potential term. This will be commented upon again in Sec. III. (c) The P. V. term plays the role of the second-order adiabatic perturbation theory of PBT^{4,13,14} and Gross.¹⁶ (d) The equation is not limited to strong coupling, but can in fact be used for the whole coupling range, in contrast to the PBT theory, since no restrictions pertaining to weak or strong coupling are built into it. (e) It should be noted that the ψ_n 's are Franck-Condon-like states^{3,8,14} as long as one is concerned only with the ground state and insists on the conditions of Eq. (16). There are no lifetime effects. It is, however, also possible to extract from Eq. (14) equations similar to Eq. (18), which describe relaxed excited states^{1,3,8} (RES) and their lifetimes, i. e., internal resonancelike states. These, however, will be discussed in a future publication.

Next, the ground-state energy for weak and strong coupling will be obtained, and a detailed connection to Hamiltonian formalisms of the polaron will be given.

III. CONNECTION WITH HAMILTONIAN FORMALISM AND GROUND-STATE ENERGY

The first objective will be to obtain the strong-coupling polaron wave function from the Green's-function formalism. To achieve this, one can use the wave-function representation for the polaron, as employed by DeWitt²⁷ and Langreth.²⁸ In second quantized notation, the polaron wave function for an electron with momentum \vec{p} (translational noninvariant) is

$$\Psi = (Z_p)^{-1/2} \lim_{\delta \rightarrow 0} \frac{i\delta}{E_0 - H + i\delta} c_p^\dagger |00\rangle, \quad (19)$$

where Z_p is the wave-function normalization constant and E_0 the polaron ground-state energy. Z_p is obtained within the Fock approximation from

$$\begin{aligned} 1 &= \langle \Psi | \Psi \rangle = (Z_p)^{-1/2} \langle \Psi | c_p^\dagger | 00 \rangle \\ &= \lim_{\delta \rightarrow 0} \frac{i\delta}{Z_p} \left\langle 00 \left| c_p^\dagger \frac{1}{E_0 - H + i\delta} c_p^\dagger \right| 00 \right\rangle \\ &= \lim_{\delta \rightarrow 0} \frac{i\delta}{Z_p} G(\vec{p}, \vec{p}; Z = E_0 + i\delta) \\ &= \psi_0^*(\vec{p}) \psi_0(\vec{p}) Z_p^{-1}, \end{aligned} \quad (20)$$

where $\psi_0(\vec{p})$ is as defined in Sec. II. Thus

$$(Z_p)^{1/2} = (\psi_0^*(\vec{p}) \psi_0(\vec{p}))^{1/2}.$$

In order to obtain Ψ , $(E_0 - H + i\delta)^{-1} c_p^\dagger |00\rangle$ is expanded in a complete set of phonon states,

$$\Psi = \sum_{\vec{p}} d(\vec{p}, \vec{p}') c_p^\dagger |00\rangle + \sum_{\vec{p}, \vec{k}_1} d(\vec{p}, \vec{p}'; \vec{k}_1) c_p^\dagger a_{\vec{k}_1}^\dagger |00\rangle + \sum_{\vec{p}, \vec{k}_1, \vec{k}_2} d(\vec{p}, \vec{p}'; \vec{k}_1, \vec{k}_2) c_p^\dagger a_{\vec{k}_1}^\dagger a_{\vec{k}_2}^\dagger |00\rangle + \dots, \quad (21)$$

where the general coefficient is given by

$$d(\vec{p}, \vec{p}'; \vec{k}_1 \dots \vec{k}_n) = \lim_{\delta \rightarrow 0} \frac{i\delta}{n!(Z_p)^{1/2}} \left\langle 00 \left| a_{\vec{k}_1}^\dagger \dots a_{\vec{k}_n}^\dagger c_p^\dagger \frac{1}{E_0 - H + i\delta} c_p^\dagger |00 \right. \right\rangle. \quad (22)$$

Using Eq. (7), all the phonon operators are commuted through to the right. After these commutations, one inserts between the resolvents a complete set of one-electron states, and a zero-phonon state. The zero intermediate-phonon states are consistent with the Fock approximation used to derive the polaron Green's-function equation of motion in Sec. II. For example,

$$d(\vec{p}, \vec{p}'; \vec{k}_1) = \lim_{\delta \rightarrow 0} \frac{i\delta}{(Z_p)^{1/2}} \left\langle 00 \left| c_p^\dagger \frac{1}{E_0 - 1 - H + i\delta} \times V_{\vec{k}_1}^\dagger \rho_{\vec{k}_1} \frac{1}{E_0 - H + i\delta} c_p^\dagger |00 \right. \right\rangle, \quad (23a)$$

$$d(\vec{p}, \vec{p}'; \vec{k}_1) \cong \lim_{\delta \rightarrow 0} \frac{i\delta}{(Z_p)^{1/2}} V_{\vec{k}_1}^\dagger \times \sum_{\vec{p}_1} G(\vec{p}', \vec{p}_1 - \vec{k}_1; Z = E_0 - 1 + i\delta) \times G(\vec{p}_1, \vec{p}; Z = E_0 + i\delta), \quad (23b)$$

$$d(\vec{p}, \vec{p}'; \vec{k}_1) = V_{\vec{k}_1}^\dagger \sum_{n, \vec{p}_1} \frac{\psi_n(\vec{p}') \psi_n^*(\vec{p}_1 - \vec{k}_1) \psi_0(\vec{p}_1)}{E_0 - 1 - E_n + i\delta}, \quad (23c)$$

$$\cong -V_{\vec{k}_1}^\dagger \rho_{\vec{k}_1}^\dagger \psi_0(\vec{p}') \text{ for large } \alpha,$$

where

$$\rho_{\vec{k}_1}^\dagger = \sum_{\vec{p}_1} \psi_0^*(\vec{p}_1 - \vec{k}_1) \psi_0(\vec{p}_1). \quad (24)$$

In Eq. (23c), the assumption that $E_0 - E_n \propto \alpha^2$ was made. The general coefficient [Eq. (22)] is obtained analogously. Thus,

$$d(\vec{p}, \vec{p}'; \vec{k}_1 \dots \vec{k}_n) = (-1)^n (n!)^{-1} V_{\vec{k}_1}^\dagger \dots V_{\vec{k}_n}^\dagger \rho_{\vec{k}_1}^\dagger \dots \rho_{\vec{k}_n}^\dagger \psi_0(\vec{p}'). \quad (25)$$

Hence,

$$\Psi = C \sum_{\vec{p}} \exp\left(-\sum_{\vec{k}} V_{\vec{k}}^\dagger \rho_{\vec{k}}^\dagger a_{\vec{k}}^\dagger\right) \psi_0(\vec{p}') c_p^\dagger |00\rangle, \quad (26)$$

where C is a normalization coefficient, which is necessary because Ψ of Eq. (26) is an approximation to the exact Ψ of Eq. (21). The normalization

coefficient is

$$C = \exp\left\{-\frac{1}{2} \sum_{\vec{k}} |V_{\vec{k}} \rho_{\vec{k}}|^2\right\}.$$

Returning to the Schroedinger representation for the electron coordinates in H and Ψ , one can then write

$$\Psi = \psi_0(\vec{r}) \exp\left[-\sum_{\vec{k}} (V_{\vec{k}}^\dagger \rho_{\vec{k}}^\dagger a_{\vec{k}}^\dagger - V_{\vec{k}} \rho_{\vec{k}} a_{\vec{k}})\right] |0\rangle, \quad (27)$$

which is the product ansatz wave function of Pekar.^{3,4}

The ground-state energy for strong coupling can now be obtained as usual by taking the expectation value of H with the wave function Ψ , or from the equation for ψ_0 [Eq. (18)] by neglecting the P. V. term (which is necessary for consistency with the approximations made to derive Ψ). This indicates that the poles of G give the polaron energy directly, in contrast to the Hartree approximation.²⁰ Thus the ψ 's here are wave functions of an electron in a self-consistent polarization well, i. e., the lattice potential energy is properly taken into account. Hence, Eq. (18) gives the same ground-state energy as $\langle H \rangle$, which is not the case in the Hartree approximation. Furthermore, the ground-state energy for weak coupling can also be obtained from this formalism. The solution of Eq. (18) in terms of a complete spectrum seems possible only for the spectrum of a fixed harmonic oscillator, because one does not know how to deal with the continuum states associated with most spectra,²⁹ in contrast to the Gaussian spectrum, which has none. On the other hand, the use of an orthogonal Gaussian spectrum in Eq. (18) is equivalent to assuming the electron is bound in a harmonic-oscillator potential, which is characterized by a single parameter, the spring constant. This can be chosen as a variational parameter. The problem should thus be equivalent to Feynman's "fixed-harmonic-oscillator" potential.⁹ In the present case, a Gaussian spectrum, characterized by a variational parameter β , is chosen, and the P. V. sum done by the use of the Slater sum rule. For details, see Appendix B. One obtains for the ground-state energy, in units of $\hbar\omega$,

$$E_0 = \frac{3}{2} \beta^2 - (\alpha/(2\pi)^{1/2} \beta) B(1/2\beta^2, \frac{1}{2}), \quad (28)$$

where $B(1/2\beta^2, \frac{1}{2})$ is the β function, defined by

$$B(1/2\beta^2, \frac{1}{2}) = \int_0^1 x^{1/2\beta^2 - 1} dx / (1-x)^{1/2}.$$

This is indeed the same result found by Feynman in the "fixed-harmonic-binding approximation" [Eqs. (33) and (34) of Ref. 9]. The variational parameter β is evaluated for small and large β , respectively. The result is $E_0 = -\alpha$ if $\alpha < 6$ and

$$E_0 = -\alpha^2/3\pi - 3 \ln 2 - O(\alpha^{-2})$$

for strong coupling (see also Appendix B).

In connection with this result, note that Eq. (14)

thus gives a solution with two asymptotic limits, one in an ascending power series of α and one in a descending power series in α^2 . For weak coupling, Eq. (14) also automatically gives a solution in which linear electron momentum is conserved, which is not the case for strong coupling. Thus the usual diagonal Fock approximation can never give the strong-coupling limit. To obtain the latter one must solve Eq. (14) noniteratively. One should also note that, although the result obtained here gives only the Feynman result for a "fixed-harmonic-binding" potential, it gives some additional information. It is clear that at $\alpha \approx 6$ there is a well-defined transition from localized to delocalized solutions, i. e., below $\alpha = 6$ no more discrete states exist. This result is similar to that obtained recently by Larsen.⁷ The reason for this, as will be shown elsewhere, is that the Lee-Low-Pines canonical transformations³⁰ employed by Larsen generate only approximations to the Fock self-energy.

An alternative approach to the weak-coupling limit is possible. Suppose that the right-hand side of Eq. (18) is discarded. Then the solution of Eq. (18) is

$$\psi_{\vec{k}}(\vec{p}) = \Omega^{-1/2} \delta(\vec{p} - \vec{k}), \quad (29)$$

i. e., a freely propagating electron with momentum \vec{k} . Iterating with these wave functions on the right-hand side of Eq. (18), after replacing n by \vec{k} , yields

$$\begin{aligned} (E_\mu - p^2) \psi_\mu(\vec{p}) &= -(\Omega^{-1}) \sum_{\vec{k}, \vec{k}_1} \frac{|V_{\vec{k}}|^2 \delta(\vec{p} - \vec{k} - \vec{k}_1) \delta(\vec{p}_1 - \vec{k} - \vec{k}_1)}{k^2 - E_\mu + 1} \psi_\mu(\vec{p}_1) \\ &= - \sum_{\vec{k}} \frac{|V_{\vec{k}}|^2}{(\vec{p} - \vec{k})^2 + 1 - E_\mu} \psi_\mu(\vec{p}). \end{aligned} \quad (30)$$

Taking the limit $E_\mu = 0$ for $\mu = 0$ on the right-hand side, one obtains the usual second-order perturbation-theory result

$$E_0 = -\alpha + p^2 / (1 + \frac{1}{6} \alpha). \quad (31)$$

The variational result agrees with Eq. (31) with $p = 0$, and since the variational result requires that $\beta = 0$, it suggests that the Gaussian spectrum becomes a continuum spectrum. The iteration procedure leading to Eq. (31) can be continued, and it generates the self-consistent perturbation theory leading to the Fock approximation.

IV. TRANSLATIONAL INVARIANCE, EFFECTIVE MASS, AND VERTEX CORRECTIONS

The question of translational invariance, i. e., the conservation of total crystal momentum, has been ignored to this point. The conservation of total crystal momentum for strong coupling can be

taken into account approximately by the technique of the Lagrange undetermined multiplier, as was done by Gross¹⁶ and Tiablikov.¹⁹ To this end, the Fröhlich Hamiltonian is rewritten

$$H = \sum_{\vec{p}} \vec{p} \cdot (\vec{p} - \vec{V}) c_{\vec{p}}^\dagger c_{\vec{p}} + \sum_{\vec{k}} \omega_{\vec{k}}(\vec{V}) a_{\vec{k}}^\dagger a_{\vec{k}} + \vec{P} \cdot \vec{V} + \sum_{\vec{k}} (V_{\vec{k}} a_{\vec{k}} \rho_{\vec{k}} + V_{\vec{k}}^\dagger a_{\vec{k}}^\dagger \rho_{\vec{k}}^\dagger), \quad (32)$$

where $\omega_{\vec{k}}(\vec{V}) = 1 - \vec{V} \cdot \vec{k}$ and \vec{V} is the Lagrange multiplier to be determined from the condition $\vec{P} = \langle \hat{P} \rangle$, where \hat{P} is the total-crystal-momentum operator. Also, following Gross¹⁶ and Tiablikov,¹⁹ m_P is identified from $\langle \hat{P} \rangle = (m_P/2m)\vec{V}$, where \vec{V} is interpreted as the polaron velocity expressed in units of $v_0 \bar{\omega}$. Note that this identification makes use of the concept of mechanical momentum (see Sec. V). Within the Fock approximation, the equation for G [analogous to Eq. (14)] is then easily obtained for the Hamiltonian given by Eq. (32). The stationary limit of this equation then yields the wave-function equation

$$\begin{aligned} (E_m - p^2 + \vec{V} \cdot \vec{p} - \vec{V} \cdot \vec{P}) \psi_m(\vec{p}) &= \sum_{\vec{k}, \vec{p}_1, n} |V_{\vec{k}}|^2 \frac{\psi_n^*(\vec{p} - \vec{k}) \psi_n(\vec{p}_1 - \vec{k}) \psi_m(\vec{p}_1)}{E_n - E_m + \omega_{\vec{k}}(\vec{V})} \end{aligned} \quad (33)$$

which is the \vec{V} -dependent analog of Eq. (18). At this point one needs to calculate $\langle \hat{P} \rangle$ to determine \vec{V} and m_P . The method of Tiablikov,¹⁹ which involves the use of the spectral representation, cannot be followed since it gives $\langle \hat{P} \rangle = 0$ in the present case. The result follows from the fact that the Fermi level is at $-\infty$ in a one-electron problem. A \vec{V} -dependent polaron wave function must therefore be used, and can be derived by the procedure employed in Sec. III. The result is the same wave function as given by Eq. (27) except with the replacement $\rho_{\vec{k}} \rightarrow \rho_{\vec{k}} / (1 - \vec{V} \cdot \vec{k})$. Then

$$\begin{aligned} \langle \hat{P} \rangle &= \langle \Psi(\vec{V}) | \vec{p} + \sum_{\vec{k}} \vec{k} a_{\vec{k}}^\dagger a_{\vec{k}} | \Psi(\vec{V}) \rangle \\ &= \frac{2}{3} \vec{V} \sum_{\vec{k}} |V_{\vec{k}}|^2 k^2 |\rho_{\vec{k}}|^2. \end{aligned} \quad (34)$$

The polaron mass is identified as discussed above, and is

$$m_P/m = \frac{4}{3} \sum_{\vec{k}} k^2 |V_{\vec{k}}|^2 |\rho_{\vec{k}}|^2.$$

In the Gaussian approximation, this is $m_P/m = 16\alpha^4/81\pi^2$, which is the same as obtained by others.^{9,13,16} Note that the free-electron contribution to the polaron mass vanishes identically since $\langle \psi_0 | p | \psi_0 \rangle = 0$. Thus, the polaron mass originates from the lattice part of the momentum only. This is reminiscent of the Feynman concept of a fictitious particle which approximates the effect of the lattice. The usual weak-coupling polaron mass may also be obtained, by following Gross¹⁶ or by an iterative technique [see Eq. (31)]. Its calculation, however, adds no further insight to the problem of transla-

tional invariance.

Consider next the effect of vertex corrections to the self-energy. In the weak-coupling limit these represent no conceptual difficulty because the self-energy can be obtained by iteration. On the other hand, a rigorous treatment of the vertex corrections in strong coupling is not easy to achieve. One already has difficulty in finding a dimensional analysis, within the present continuum representation of the Green's function, which leads to a descending power series in α^2 for the energy, as is expected intuitively. The Fock approximation provides a zeroth-order description of the strong-coupling limit, which corresponds to the adiabatic approximation of other theories. It turns out not to be true, however, that the vertex contributions can then be treated as a perturbation to the Fock-approximation Green's function. For example, the second term of Eq. (12) contributes a leading term of order α^4 . Successively higher-order vertex terms start with leading terms of order $\alpha^6, \alpha^8, \dots$.³¹ Each vertex term also has a descending power series in α^2 associated with it.

The technique of Hamiltonian renormalization can be attempted as an alternative approach to the vertex corrections. Thus, as was shown earlier, with the help of the Fock approximation, one can generate the well-known unitary operator $S = \exp[-(\sum_{\vec{k}} V_{\vec{k}}^\dagger \rho_{\vec{k}}^\dagger a_{\vec{k}}^\dagger - \text{c. c.})]$, which has the property

$$S a_{\vec{k}}^\dagger S^{-1} = a_{\vec{k}}^\dagger + V_{\vec{k}}^\dagger \rho_{\vec{k}}^\dagger \equiv \beta_{\vec{k}}^\dagger. \quad (35)$$

Expressing the $a_{\vec{k}}^\dagger, a_{\vec{k}}$ operators in the Fröhlich Hamiltonian in terms of the $\beta_{\vec{k}}^\dagger, \beta_{\vec{k}}$ operators, one obtains a new Hamiltonian $H_0 + H_{\text{int}}$, where

$$H_0 = -\nabla^2 + \sum_{\vec{k}} |V_{\vec{k}}|^2 |\rho_{\vec{k}}|^2 - 2 \sum_{\vec{k}} |V_{\vec{k}}|^2 \rho_{\vec{k}} e^{-i\vec{k}\cdot\vec{r}} + \sum_{\vec{k}} \beta_{\vec{k}}^\dagger \beta_{\vec{k}}, \quad (36)$$

$$H_{\text{int}} = \sum_{\vec{k}} [V_{\vec{k}}^\dagger (e^{-i\vec{k}\cdot\vec{r}} - \rho_{\vec{k}}^\dagger) \beta_{\vec{k}}^\dagger + V_{\vec{k}} (e^{i\vec{k}\cdot\vec{r}} - \rho_{\vec{k}}) \beta_{\vec{k}}]. \quad (37)$$

This separation is the same as that given by Hühler,³² and forms the start of his adiabatic perturbation theory. The equation

$$(H_0 - \sum_{\vec{k}} \beta_{\vec{k}}^\dagger \beta_{\vec{k}}) \psi_s = \epsilon_s \psi_s \quad (38)$$

then determines a zero-order electron Franck-Condon spectrum. It is now easy to develop a perturbation theory on the basis of this Hamiltonian renormalization. Some of the results follow. To second order, one obtains the usual correction to the self-energy

$$\Sigma_i^{(2)}(Z) = \sum_{\vec{k}, l \neq i} \frac{|V_{\vec{k}}|^2 \rho_{il}(\vec{k}) \rho_{li}^\dagger(\vec{k})}{Z - E_l - 1}, \quad (39)$$

where i refers to the ground state and

$$\rho_{il}(\vec{k}) = \int e^{i\vec{k}\cdot\vec{r}} \psi_i^*(\vec{r}) \psi_l(\vec{r}) d\vec{r}.$$

The reason one has $l \neq i$ in the above equation is due to the relation

$$\langle i | H_{\text{int}} | l \rangle \propto \delta_{li} \quad (40)$$

which holds only if i refers to the ground state.

Equation (39) is the usual result for the fluctuation energy³³ if $Z = E_0$, which is valid for strong coupling only because of the way H_0 was defined. It represents the correction to the strong-coupling ground-state energy, within the Fock approximation and a Gaussian spectrum, and thus gives the same result as the P.V. sum of Eq. (18) does.

The next term in the perturbation expansion consists of two contributions, both fourth-order in perturbation theory. One is Fock-like and the other represents the first vertex correction. One can readily verify that both contributions have leading terms of order α^0 . The reason for this is that the selection rule [Eq. (40)] does not apply for matrix elements involving only virtual states. It is then not difficult to ascertain that because of this, in the n th-order perturbation, the leading contribution is also of order α^0 . Thus, according to the Hühler adiabatic perturbation theory, *all* perturbation terms begin with α^0 corrections to the ground-state energy. This then raises questions about convergence. In particular, one wonders whether the constant term of $-\frac{3}{4}$, as given by Feynman, can emerge as suggested by Hühler and Mullensiefen.³⁴

Finally, it should be noted that the adiabatic perturbation theory cannot be applied to calculate corrections to the excited Franck-Condon states. The selection rule [Eq. (40)] does not apply at all in that case, and the perturbation theory then gives an ascending power series in α^2 in addition to one in descending powers of α^2 . This is the same result as was obtained earlier where a Hamiltonian renormalization was not used.

In conclusion, it seems that in strong coupling the vertex terms lead to difficulties, which are not well understood. Although the adiabatic perturbation theory of Hühler does appear to indicate that vertex terms do not contribute to order α^2 in the energy, it is not clear what happens to order α^0 . The difficulty lies in the fact that H_{int} [Eq. (37)] has no small parameter in it. The nonperturbative character of Eq. (37) is thus similar to that of the interaction Hamiltonian obtained in the adiabatic theory of PBT.^{13,14} However, in that theory the H_{int} can be handled nonperturbatively.¹³ The possibility of finding a corresponding Green's-function analysis is currently being investigated.

V. FINAL CONSIDERATIONS

To conclude this paper some discussion on new results and remaining problems will be given. It has been shown that the zeroth-order description of the strong-coupling limit can be obtained from

the Fock approximation of the polaron self-energy, in which the origin is a special coordinate, i. e., translational invariance is violated. This finding is in contrast to existing beliefs that the strong-coupling energy is based on the Hartree approximation.^{3,4,13,14,19,20}

The difference between the Hartree and Fock approximations is that the former leads to a static limit, and therefore conforms to the notion of Hamiltonian dynamics which requires local interactions in time, whereas the Fock approximation leads to retarded interactions. This may be why the strong-interaction limit has been attributed to the Hartree approximation. Yet, it is important to realize that the retarded interaction embodied in the Fock approximation is of a special kind, i. e., it depends only on time differences, and that for a large time difference, stationary states can be obtained. Thus it has been shown explicitly here how the Fock approximation is connected with canonical transformations used to obtain lowest-order results of PBT.^{12,13} In this connection, note that the adiabatic perturbation theory of Hohler³² predicts corrections to the Pekar theory which are of order α^0 to all orders of perturbation theory, indicating that the vertex corrections to the strong-coupling adiabatic limit cannot be obtained by perturbation theory.

Concerning the theory of Feynman the situation seems to be as follows. Feynman has used two trial actions. The first one, the "fixed-harmonic binding approximation," corresponds to the non-diagonal Fock approximation, as is evident from a comparison of the two results.³⁵ The discontinuity in the ground-state energy at $\alpha \approx 6$ then corresponds to a transition from strong (localized electron) to weak (delocalized electron) coupling. The second model considered by Feynman is the "fictitious-particle model," i. e., the effect of the lattice is replaced by a fictitious particle harmonically bound to the electron. The introduction of this fictitious particle accomplishes two things. For one, translational invariance is introduced since the electron fictitious-particle complex implies center of mass and relative coordinates for the polaron. For another, vertex corrections to the self-energy are also taken into account. This is evident if one considers the weak-coupling limit. In that limit, it is known that, up to fourth-order perturbation theory, the two Fock terms together are positive and the vertex term large and negative, the net result being the usual negative α^2 term (see Appendix C) which Feynman approximates quite closely.^{34,36} On the other hand, with regard to the strong-coupling limit, it is not quite clear whether the energy term of $-\frac{3}{4}$, which has been called the localization energy by Allcock,^{13,33} arises from vertex corrections. It is worth emphasizing that the "fictitious-particle model" predicts that $\alpha_c = 0$.

Thus, it appears that the vertex terms permit a localized ground-state solution, even for weak coupling, which, as was seen earlier, is not the case for the Fock approximation alone. It is as if the vertex terms act as an effective potential, which has at least one bound (localized) state for all coupling strengths.

The question of translational invariance also merits some further comments, particularly in connection with the Fock approximation and the calculation of the effective mass of the polaron. Thus it was shown here how to obtain the polaron mass by requiring that the conventional momentum (which involves mass transport) be conserved (see Sec. IV). Translational invariance is used in the sense that the Pekar-product wave function is made to be an approximate eigenfunction of the mechanical-momentum operator, and not the crystal-momentum operator. The latter, however, is the starting point in the analysis involving the Lagrange multiplier technique, for example. As has been emphasized in the literature,^{3,4,13,14} both these momenta are conserved, and represent distinct conservation laws. Their hybrid use to obtain the polaron mass thus seems to require further elucidation.

The problem becomes even more acute when crystal-momentum conservation is treated exactly. The Fock approximation, it is well known, then becomes diagonal,

$$\Sigma_F(\vec{P}, Z) = \sum_{\vec{k}} |V_{\vec{k}}|^2 G(\vec{P} - \vec{k}, Z - 1).$$

Here \vec{P} is now the total polaron crystal momentum, rather than the electron momentum. It is known, however, that this self-energy does not preserve $E_0 = -\alpha$ as an upper bound for weak coupling,²⁰ and because Σ_F is diagonal, the strong-coupling limit is lost altogether. However, since crystal-momentum conservation is required, and since most previous strong-coupling theories rest on the non-diagonal Fock approximation, there appears to be some doubt about the complete correctness of existing theories. This problem has been pursued in some detail. It turns out that one can apply crystal-momentum conservation rigorously in the strong-coupling limit, in the same way as has been done in the weak-coupling limit, and find a variational principle which minimizes the ground-state energy for a given crystal momentum. It then appears that previous strong-coupling theories are indeed incomplete. However, since the main thrust of this paper was directed towards a Green's-function analysis of previous theories, these new results will be reported in a future publication.

A preliminary account of the work presented here has already appeared elsewhere.³⁷

ACKNOWLEDGMENT

The authors would like to thank Dr. K. H. Bennemann for helpful discussions.

APPENDIX A

It is the purpose here to elucidate the derivation of Eq. (18) and the connection to the usual Tamm-Dancoff equations. Consider the total polaron wave function^{28,29}

$$\Psi = (Z_p)^{-1/2} \lim_{\delta \rightarrow 0} \frac{i\delta}{E - H + i\delta} c_p^\dagger |00\rangle. \quad (\text{A1})$$

This wave function is dependent both on electron and phonon coordinates. The variational principle then requires that the polaron energy E be a minimum, i. e.,

$$\delta E = \delta \langle \Psi | H | \Psi \rangle / \langle \Psi | \Psi \rangle = 0$$

which leads to

$$\delta \langle \Psi | H - E | \Psi \rangle = 0. \quad (\text{A2})$$

The variation is both for the electron and lattice part of Ψ . The usual Tamm-Dancoff equations are obtained by expanding Ψ in the manner of Eq. (21), the coefficients being given by Eq. (22). Substituting Eq. (21) into (A2) and performing a functional minimization with respect to the d 's then gives the Tamm-Dancoff equations, the first two of which are

$$(E - p^2) d(\vec{p}, \vec{p}') = \sum_{\vec{k}} V_k d(\vec{p} - \vec{k}, \vec{p}'; \vec{k}), \quad (\text{A3})$$

$$[E - (\vec{p} - \vec{k})^2 - 1] d(\vec{p} - \vec{k}, \vec{p}'; \vec{k}) = V_k^\dagger d(\vec{p}, \vec{p}') + 2 \sum_{\vec{q}} V_q d(\vec{p} - \vec{q} - \vec{k}; \vec{p}'; \vec{q}, \vec{k}). \quad (\text{A4})$$

Note that the minimization is with respect to the lattice coordinates for a fixed-electron-charge-density configuration. This is indicated by the elec-

tron coordinates \vec{p} and \vec{p}' in the d 's. In solving these equations one effectively eliminates the lattice coordinates in terms of the electron coordinates. This solution is usually obtained by iteration, which is equivalent to doing W-B perturbation theory (∞ -order selective diagrammatic summation). On the other hand, one may eliminate the lattice coordinates to a certain order by making use of the definition of the d 's, Eq. (22). Thus in Eq. (A3), $d(\vec{p} - \vec{k}, \vec{p}'; \vec{k})$ can be rewritten in the manner of Eqs. (23a) and (23b), which involves the electron Green's functions with arguments $Z = E - 1 + i\delta$ and $Z = E + i\delta$. These Green's functions must have a spectrum of poles and possibly a branch cut in frequency space, which is expressed by the expansion Eq. (15). Taking the limit of $\delta \rightarrow 0$ and integrating out the functions with argument \vec{p}' leads to Eq. (18). The transformation which produced Eq. (18) from Eq. (A3) is unitary for strong coupling as was shown explicitly in Sec. III. Unitarity is not so easily demonstrated for weak and intermediate coupling. It will, however, be assumed that the transformation is unitary for all coupling, since the resulting Fock equation has a symmetric and definite kernel. Furthermore, one can easily verify from Eqs. (A3) and (A4) that Eq. (18) (the Fock approximation) is basically a one-phonon Tamm-Dancoff approximation [renormalized by replacing $G_0(E - 1)$ by $G(E - 1)$]. These two factors then allow one to minimize Eq. (18) and be sure that one still has an upper bound to the polaron energy. Note, however, that the minimization must be done in terms of a complete electron spectrum.

APPENDIX B

An estimate of the ground-state energy can be obtained variationally from Eq. (18). After Fourier transformation, Eq. (18) becomes

$$-\frac{1}{2} \nabla^2 \psi_0(\vec{r}) - \frac{\pi\alpha}{(2\pi)^3} \sum_n \iint \frac{d\vec{r}_1 d\vec{k}}{k^2} e^{-i\vec{k} \cdot (\vec{r} - \vec{r}_1)} \psi_n(\vec{r}) \psi_n^*(\vec{r}_1) \psi_0(\vec{r}_1) / (\lambda_n - \lambda_0 + \frac{1}{2}) = \lambda_0 \psi_0(\vec{r}), \quad (\text{B1})$$

where $2\lambda_n = E_n$ and the $\psi_n(\vec{r})$ are defined over all r . Equation (B1) can be rewritten

$$\lambda_0 = -\frac{1}{2} \int \psi_0^*(\vec{r}) \nabla^2 \psi_0(\vec{r}) d\vec{r} - \frac{\pi\alpha}{(2\pi)^3} \sum_n \iiint \frac{d\vec{r}_1 d\vec{r} d\vec{k}}{k^2} e^{-i\vec{k} \cdot (\vec{r} - \vec{r}_1)} \psi_0(\vec{r}_1) \psi_0^*(\vec{r}) \psi_n^*(\vec{r}_1) \psi_n(\vec{r}) / (\lambda_n - \lambda_0 + \frac{1}{2}), \quad (\text{B2})$$

and λ_0 estimated by the use of a complete trial spectrum whose eigenvalue separation is determined by the variational parameter. The trial spectrum is chosen to be the solution of the harmonic-oscillator equation, which is obtained from Eq. (B1) by the replacement of the second term on the left-hand side by $\frac{1}{2} \omega^2 r^2 \psi_0(\vec{r})$. The trial functions are then normalized-harmonic-oscillator functions

$$\psi_n(x) = \left(\frac{\beta}{\pi} \right)^{1/2} \frac{1}{2^n n!} H_n(\beta x) e^{-\beta^2 x^2 / 2}$$

(Cartesian Coordinates), where β is the variational parameter and $\omega = \beta^2$ so that $\lambda_n - \lambda_0 = n \omega = n \beta^2$. The trial spectrum is substituted into the right-hand side of Eq. (B2). After writing

$$(\lambda_n - \lambda_0 + \frac{1}{2})^{-1} = \int_0^\infty e^{-(\lambda_n - \lambda_0 + 1/2)t} dt \quad (\text{B3})$$

and $\lambda_n - \lambda_0 = n\omega$, and transforming variables in Eq. (B2) to $\beta \vec{r} = \vec{\xi}$ and $\vec{k} = \beta \vec{K}$, one performs the sum over n using the Slater sum rule for the harmonic-oscillator spectrum,

$$\sum_{n=0}^{\infty} \phi_n^*(\vec{\xi}) \phi_n(\vec{\xi}') e^{-\gamma n} = e^{3\gamma/2} (2\pi \sinh \gamma)^{-3/2} \\ \times \exp\left\{-\frac{1}{4}\left[(\vec{\xi} + \vec{\xi}')^2 \tanh \frac{1}{2}\gamma + (\vec{\xi} - \vec{\xi}') \coth \frac{1}{2}\gamma\right]\right\}. \quad (\text{B4})$$

After all the integrations are performed, the expression for the energy is

$$E_0(\beta) = 2\lambda_0 \\ = \frac{3}{2}\beta^2 - (2/\pi)^{1/2}(\alpha\beta/2\omega)B(1/2\omega, \frac{1}{2}), \quad (\text{B5})$$

where $\omega = \beta^2$ and B is the β function defined by

$$B(\mu, \nu) = \int_0^1 r^{\mu-1} (1-r)^{\nu-1} dr. \quad (\text{B6})$$

For large and small β

$$E_0(\beta) = \frac{3}{2}\beta^2 - (2/\pi)^{1/2}\alpha\beta[1 + \ln Z/\beta^2 + O(\beta^4)], \\ (\text{large } \beta)$$

$$E_0(\beta) = -\alpha + (\frac{1}{4}\beta^2)(6 - \alpha) - O(\beta^4) \quad (\text{small } \beta).$$

For $\alpha > 6$, minimization of $E_0(\beta)$ with respect to β gives $\beta = \frac{1}{3}\alpha(2/\pi)^{1/2}$ and $E_0 = -\alpha^2/3\pi - 3\ln 2 + O(\alpha^{-2})$. For $\alpha < 6$, minimization gives $\beta = 0$ and $E_0 = -\alpha$.

APPENDIX C

Since reference is made in the paper to the results of fourth-order perturbation theory, that cal-

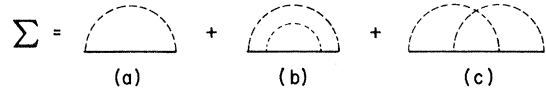

FIG. 1. Electron self-energy diagrams which contribute to order α and α^2 .

ulation will be briefly described. The diagrams contributing to order α^2 in the energy are shown in Fig. 1.

To order α^2 , the total self-energy is

$$\Sigma_T = \Sigma_a + \Sigma_b + \Sigma_c,$$

where a , b , and c refer to diagrams (a), (b), and (c) of Fig. 1. Numerically, these are

$$\Sigma_a = -\alpha + \sum_{\vec{k}_1, \vec{k}_2} \frac{|V_{\vec{k}_1}|^2}{(1+k_1^2)^2} \frac{|V_{\vec{k}_2}|^2}{(1+k_2^2)^2} = -\alpha + \frac{1}{2}\alpha^2,$$

$$\Sigma_b = -\sum_{\vec{k}_1, \vec{k}_2} \frac{|V_{\vec{k}_1}|^2 |V_{\vec{k}_2}|^2}{(1+k_1^2)^2 [2 + (\vec{k}_1 + \vec{k}_2)^2]} \\ = -\alpha^2 [\ln(1 + 1/\sqrt{2}) - 1/(2 + 2\sqrt{2})] \\ = -0.3280\alpha^2,$$

$$\Sigma_c = -\sum_{\vec{k}_1, \vec{k}_2} \frac{|V_{\vec{k}_1}|^2 |V_{\vec{k}_2}|^2}{(1+k_1^2)(1+k_2^2)[2 + (\vec{k}_1 + \vec{k}_2)^2]} \\ = -\alpha^2 [\ln(1 + \sqrt{2}) - \ln 2] \\ = -0.1879\alpha^2.$$

¹J. Appel, in *Solid State Physics*, edited by F. Seitz, D. Turnbull, and H. Ehrenreich (Academic, New York, 1968), Vol. 21.

²*Polarons and Excitons*, edited by C. G. Kuper and G. D. Whitfield (Plenum, New York, 1962).

³T. D. Schultz, Solid State and Molecular Theory Group, MIT, Technical Report No. 9, Cambridge, Mass., 1956 (unpublished).

⁴H. Fröhlich, *Advan. Phys.* **3**, 325 (1954).

⁵D. Pines in Ref. 2, p. 155.

⁶D. Larsen, *Phys. Rev.* **172**, 967 (1968).

⁷D. Larsen, *Phys. Rev.* **187**, 1147 (1969).

⁸E. Kartheuser, R. Evrard, and J. Devreese, *Phys. Rev. Letters* **22**, 94 (1969).

⁹R. P. Feynman, *Phys. Rev.* **97**, 660 (1955).

¹⁰R. P. Feynman, R. W. Hellwarth, C. K. Iddings, and P. M. Platzman *Phys. Rev.* **127**, 1004 (1962); P. M. Platzman in Ref. 2, p. 123.

¹¹S. I. Pekar, *Zh. Eksperim. i Teor. Fiz.* **19**, 796 (1949); **16**, 335, (1946); **16**, 341 (1946).

¹²N. M. Bogolubov and S. V. Tiablikov, *Zh. Eksperim. i Teor. Fiz.* **19**, 256 (1949).

¹³G. R. Allcock in Ref. 2, p. 45.

¹⁴G. Höhler, *Field Theory and Many Body Problem*, edited by E. R. Caianiello (Academic, New York, 1961) p. 285.

¹⁵S. V. Tiablikov, *Zh. Eksperim. i Teor. Fiz.* **25**, 688 (1953).

¹⁶E. P. Gross, *Ann. Phys. (N. Y.)* **8**, 78 (1959).

¹⁷V. M. Buimstrov and S. T. Pekar, *Zh. Eksperim. i Teor. Fiz.* **33**, 1271 (1957) [*Sov. Phys. JETP* **6**, 977 (1958)].

¹⁸M. Porsch and J. Röseler, *Phys. Status Solidi* **23**, 365 (1967).

¹⁹S. V. Tiablikov, *Fiz. Tverd. Tela* **3**, 3445 (1961) [*Sov. Phys. Solid State* **3**, 2500 (1962)].

²⁰R. Puff and G. Whitfield in Ref. 2, p. 171.

²¹M. Porsch, *Phys. Status Solidi* **39**, 477 (1970).

²²A. Messiah, *Quantum Mechanics* (North-Holland, Amsterdam, 1962).

²³D. Larsen, *Phys. Rev.* **144**, 697 (1966).

²⁴A. A. Abrikosov, L. P. Gorkov, and I. E. Dzyaloshinskii, *Methods of Quantum Field Theory* (Prentice-Hall, Englewood Cliffs, N. J. 1963).

²⁵G. D. Whitfield and R. Puff, *Phys. Rev.* **139**, A338 (1965).

²⁶W. Van Haeringen, *Phys. Rev.* **137**, A1902 (1965).

²⁷B. S. DeWitt, *Phys. Rev.* **100**, 905 (1955).

²⁸D. C. Langreth, *Phys. Rev.* **137**, A760 (1965).

²⁹A. Delgarno and J. T. Lewis, *Proc. Roy. Soc. (London)* **A233**, 70 (1956).

³⁰T. D. Lee, F. Low, and D. Pines, *Phys. Rev.* **90**, 297 (1953).

³¹If one tries the self-consistent perturbation-theory generalization employed by Tiablikov, one encounters similar difficulties. In this case, terms like the $m \neq 0$

contributions to the right-hand side of Eq. (18) and vertex terms all have leading terms of order α in the energy.

³²G. Höhler, *Nuovo Cimento* **11**, 691 (1955).

³³G. R. Allcock, *Advan. Phys.* **5**, 412 (1956).

³⁴G. Höhler and Mullensiefen, *Z. Physik* **157**, 159 (1959).

³⁵Note that this is also the result obtained by Gross (see Ref. 16).

³⁶T. D. Lee and D. Pines, *Phys. Rev.* **88**, 960 (1952).

³⁷D. Matz and B. C. Burkey, *Solid State Commun.* **8**, 1887 (1970).

Raman Spectra of the Alkali Azides: KN_3 , RbN_3 , CsN_3 †

C. E. Hathaway and Paul A. Temple

Department of Physics, Kansas State University, Manhattan, Kansas 66502

(Received 23 October 1970)

The first-order Raman spectra of KN_3 , RbN_3 , and CsN_3 , all of which possess a body-centered tetragonal crystal structure with the symmetry of the space group $D_{4h}^{18}-I4/mcm$, have been measured at room and liquid-nitrogen temperatures. The five Raman-active phonons predicted by group theory have been observed and assigned on the basis of the scattering tensors.

INTRODUCTION

Many of the solid inorganic azides decompose to give the simple products of the anion and nitrogen. This decomposition may be caused by heat, shock, light, or ionizing radiation. In the case of the heavy-metal azides the reaction can be highly exothermic. However, some of the azides, in particular the alkali azides, are more stable. Therefore the alkali azides have been the subject of many studies.

Considerable work has been done on the vibrational spectra of the alkali-metal azides. Bryant¹⁻⁴ has presented extensive infrared data on single crystals of sodium, potassium, and cesium azide and some mercury-arc Raman data on polycrystalline alkali azides. Recently, the long-wavelength translatory optical frequencies for KN_3 , RbN_3 , and CsN_3 have been measured by far-infrared transmission on polycrystalline samples.⁵ Also an attempt has been made recently to calculate on the basis of a rigid-ion approximation the lattice vibrational frequencies of potassium, rubidium, and cesium azide.⁶ Because of our interest in Raman scattering from radiation-induced defects in the alkali azides,^{7,8} we have undertaken a study of the laser Raman spectra of these alkali azides. The present study has allowed a definitive assignment of the first-order Raman-active phonons.

Potassium, rubidium, and cesium azide possess a body-centered tetragonal crystal structure with the symmetry of the space group $D_{4h}^{18}-I4/mcm$.⁹ The crystal structure is shown in Fig. 1. There are four formula units per crystallographic unit cell and two formula units per primitive cell. The crystallographic unit-cell parameters for these alkali azides are listed in Table I. As the effective ionic

radius of the metal ion is increased the unit-cell dimensions are correspondingly increased. However, these changes are such that the contact radius between the metal ion and the end nitrogen of the azide ion is the same for all three materials.

Group theory indicates that the 24 deg of freedom for the 8 atoms in each primitive cell are divided into vibrations at $k=0$ of the symmetries indicated

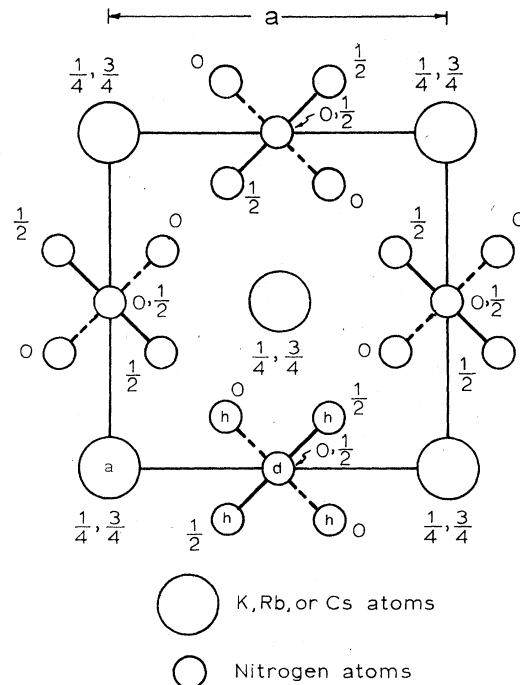

FIG. 1. Crystallographic unit cell of the alkali azides possessing the symmetry of the space group $D_{4h}^{18}-I4/mcm$. Letters a , d , and h refer to the special positions of D_{4h}^{18} . Fourfold z axis is normal to the figure.