

Optical properties of quasi-two-dimensional systems: Nonlocal effects

Luis Mochán and Rubén G. Barrera

Instituto de Física, Universidad Nacional Autónoma de México, Apartado Postal 20-364, México 20, D.F. México

(Received 17 September 1980)

We obtain formulas for the reflection amplitude for *s*- and *p*-polarized light of a quasi-two-dimensional system in terms of averages of its conductivity response to the electric and displacement fields. Then we apply our results to a simple model Hamiltonian with parameters adjusted to an inversion layer and to a metallic monolayer in order to compare the reflectance, the ellipsometric coefficients, and the electric field calculated with a nonlocal response versus the ones calculated with several local approximations derived from the same Hamiltonian.

I. INTRODUCTION

There has been recent interest in the optical properties of quasi-two-dimensional systems. Some instances of these systems are electrons trapped by liquid helium, magnetic surface states, and adsorbed overlayers. The transition layer around the interface between a medium and vacuum, in which the response functions of the medium differ from their bulk values, can sometimes be considered a quasi-two-dimensional system.¹⁻³ Inversion and accumulation layers⁴ in metal-oxide-semiconductor (MOS) structures seem to be the most intensely investigated systems, both theoretically⁵⁻¹⁴ and experimentally,^{15,16} since they are quasi-two-dimensional electron gases whose density can be easily varied so that many-body effects can be displayed.^{17,18} Inversion layers are formed when an electric field perpendicular to the interface between the oxide and the semiconductor bends the energy bands of the latter so much that they cross the Fermi level. The energy levels in inversion layers form two-dimensional subbands, each of which corresponds to a quantized level for motion in the direction normal to the interface.

The differential absorptance of MOS structures with and without inversion layers has been measured^{15,16} obtaining resonances that differ from the intersubband energies as calculated in the Hartree approximation. The reason for this is found in many-body¹⁴ and polarization⁶ effects, both of which are of the same order of magnitude.⁸ Due to the polarization effects, the electronic motion in the direction normal to the interface is better described by the conductivity \hat{S} (current-displacement-field response function) rather than by the usual conductivity $\hat{\sigma}$ (current-electric-field response function).⁸ Of course, many-body effects are to be taken into account when both $\hat{\sigma}$ and \hat{S} are calculated.

There is also a great deal of interest in the study of surface excitations (surface polaritons, surface plasmons, etc.¹⁹) and their dispersion relations have

been calculated for extreme two dimensional²⁰ and for several local¹⁰ and nonlocal^{5,11} quasi-two-dimensional systems.

Both absorption and the surface excitation dispersion relations,^{21,22} as well as several surface properties like reflectance, ellipsometric coefficients, surface admittance, image forces, inelastic electron reflection, and dispersion forces²³ can be simply calculated from the complex amplitude reflection and transmission coefficients for *s*- and *p*-polarized light. We will refer to these, as well as to the closely related reflectance and ellipsometric coefficients, as the optical coefficients. It is on these that we center our attention in this paper.

The simple interpretations of reflectometric and ellipsometric measurements are given in terms of local, homogeneous, and isotropic response functions.²⁴ Nevertheless, the response functions of a medium are in general nonlocal. There have been many attempts to calculate the electromagnetic properties of nonlocal systems with an abrupt interface in terms of their bulk (translationally invariant) response functions.²⁵⁻³⁶ However, we are interested in quasi-two-dimensional systems which have a smoothly varying density in one direction and therefore have translational symmetry only in a plane. The fields and the reflection coefficient for the jellium model of a semi-infinite metal have been calculated taking into account the transition layer.^{37,38} However the sole calculation of the response functions involves already a long numerical analysis,³ and up to now, there has been no definite *quantitative* calculation of the importance of nonlocal effects in the optical coefficients of quantum-mechanical systems with nonabrupt interfaces. The aim of this paper is precisely to make this quantitative determination for a very simple model of a quasi-two-dimensional system. Our main interest in this article is not the model of the system itself but rather the comparison of the optical properties of the system calculated with a nonlocal theory with the ones obtained with a local theory. In order to isolate

the nonlocal effects we start from a simple model Hamiltonian from which we calculate the nonlocal conductivity tensor, then we make different local approximations to it and calculate the corresponding optical coefficients. The only justification for our choice of Hamiltonian is its simplicity. Of course more realistic Hamiltonians can be constructed¹³ and they will be considered in future publications.

The structure of the paper is as follows: in Sec. II we develop, following the perturbative approach of Bagchi *et al.*² a formalism for the calculation of the optical coefficients of an isolated quasi-two-dimensional system in terms of its, in general nonlocal and anisotropic, current response to the electric and the displacement fields. The more realistic case of a quasi-two-dimensional system over a substrate can then be easily generated using for example, standard multilayered film optics³⁹ and it will be done elsewhere. Then we calculate the optical coefficients taking into account that the fields radiated by the system act on itself. This leads to a "renormalization" of the reflection coefficient, whose poles give the long-wavelength limit for the surface-excitations dispersion relations. In Sec. III we introduce different local approximations to the response functions and discuss their effect on the optical coefficients. In Sec. IV we introduce our model Hamiltonian for the quasi-two-dimensional system and perform a quantum-mechanical calculation of the conductivity tensor within the random-phase approximation (RPA). In Sec. V we adjust the parameters of our model to typical inversion or accumulation layers and to metallic monolayers and we make a quantitative comparison of the optical coefficients and the electric fields between the different models introduced in Sec. III. Section VI is devoted to conclusions.

II. CALCULATION OF THE OPTICAL COEFFICIENTS FOR QUASI-TWO-DIMENSIONAL SYSTEMS

We consider a quasi-two-dimensional system placed symmetrically around $z=0$ with translational invariance in the XY plane and characterized by a diagonal (although not necessarily isotropic) nonlocal conductivity tensor with respect to the coordinate system shown in Fig. 1. With this last assumption the s and p character of the polarization of light is preserved under reflection and refraction.

In order to calculate the complex reflection and transmission coefficients we have to solve Maxwell's equations for the electric field \vec{E} , that is

$$\vec{\nabla}(\vec{\nabla} \cdot \vec{E}) - \nabla^2 \vec{E} = \frac{\omega^2}{c^2} \vec{D} \quad (1)$$

where \vec{D} is the displacement vector and c is the speed of light. Making use of the translational invariance

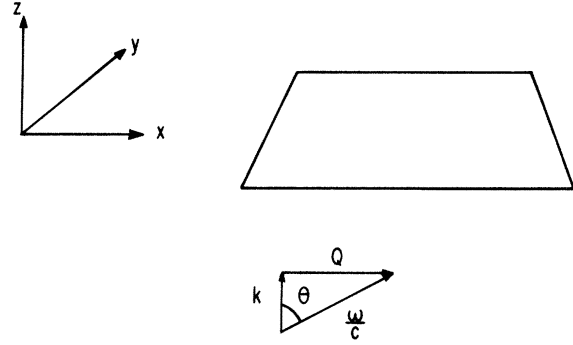

FIG. 1. Geometry of the system showing the Cartesian coordinate system, the incident wave-vector components Q and k , and the angle of incidence θ . The system lies in the XY plane and XZ is the plane of incidence.

in the XY plane \vec{D} is related to \vec{E} by

$$D^\mu(\vec{\rho}, z; t) = \int \int \int \epsilon^{\mu\nu}(\vec{\rho} - \vec{\rho}', z, z'; t - t') \times E^\nu(\vec{\rho}', z'; t') d^2\rho' dz' dt' \quad (2)$$

Here $\vec{\rho}$ is the projection of $\vec{r} = (x, y, z)$ on the XY plane, $\epsilon^{\mu\nu}$ is the nonlocal dielectric tensor, Greek superscripts refer to Cartesian components, and summation over repeated indices is assumed. Using the convolution theorem Eq. (2) can also be written as

$$D_{\vec{Q}, \omega}^\mu = \int \epsilon_{\vec{Q}, \omega}^{\mu\nu}(z, z') E_{\vec{Q}, \omega}^\nu(z') dz' \quad (3)$$

where we have Fourier transformed the fields as

$$D^\mu(\vec{\rho}, z; t) = \int \int D_{\vec{Q}, \omega}^\mu(z) \exp[i(\vec{Q} \cdot \vec{\rho} - \omega t)] \times \frac{d^2Q}{(2\pi)^2} \frac{d\omega}{2\pi} \quad (4a)$$

and the response functions as

$$\epsilon^{\mu\nu}(\vec{\rho} - \vec{\rho}', z, z'; t - t') = \int \int \epsilon_{\vec{Q}, \omega}^{\mu\nu}(z, z') \exp\{i[\vec{Q} \cdot (\vec{\rho} - \vec{\rho}') - \omega(t - t')]\} \frac{d^2Q}{(2\pi)^2} \frac{d\omega}{2\pi} \quad (4b)$$

\vec{Q} is a wave vector parallel to the XY plane and ω is the frequency.

The integral relation between $\vec{D}_{\vec{Q}, \omega}$ and $\vec{E}_{\vec{Q}, \omega}$ given by Eq. (3) can be written more concisely as

$$\vec{D}_{\vec{Q}, \omega} = \hat{\epsilon}_{\vec{Q}, \omega} \vec{E}_{\vec{Q}, \omega} \quad (5)$$

where $\hat{\epsilon}_{\vec{Q}, \omega}$ is then an integral operator. In the following the symbol $\hat{\cdot}$ on a response function will indicate its corresponding integral operator.

Using this notation the definition of the conductivity operator can be then written as

$$\hat{\epsilon}_{\bar{Q},\omega} \equiv \underline{1} + \frac{4\pi i}{\omega} \hat{\sigma}_{\bar{Q},\omega}, \quad (6)$$

where $\underline{1}$ is the identity. Using Eqs. (4), (5), and (6), Maxwell's equation [Eq. (1)] becomes

$$\begin{aligned} & \left[i\bar{Q}, \frac{\partial}{\partial z} \right] \left[\left[i\bar{Q}, \frac{\partial}{\partial z} \right] \cdot \bar{E}_{\bar{Q},\omega}(z) \right] \\ & + \left[Q^2 - \frac{\omega^2}{c^2} - \frac{\partial^2}{\partial z^2} \right] \bar{E}_{\bar{Q},\omega}(z) = \frac{4\pi i \omega}{c^2} (\hat{\sigma}_{\bar{Q},\omega} \cdot \bar{E}_{\bar{Q},\omega}). \end{aligned} \quad (7)$$

We now solve this equation for s and p polarization separately choosing the XZ plane as the plane of incidence thus $\bar{Q} = (Q, 0, 0)$ (see Fig. 1).

In order to avoid a cumbersome notation, in what follows we will omit the arguments z and/or z' and the subindices \bar{Q}, ω unless it could lead to confusion. We also introduce

$$\langle f(z) \rangle \equiv \int f(z, z') dz',$$

$$\langle \langle f \rangle \rangle \equiv \int \int f(z, z') dz dz'$$

for any function of two variables.

A. s polarization

In this case $\bar{E} = (0, E_y, 0)$ thus Eq. (7) becomes

$$\left[\frac{d^2}{dz^2} + k^2 \right] E_y = -\frac{4\pi i \omega}{c^2} (\hat{\sigma} \bar{E})_y, \quad (8a)$$

where

$$k^2 = \frac{\omega^2}{c^2} - Q^2. \quad (8b)$$

This integro-differential equation can now be transformed into the following integral equation

$$E_y = u - \frac{4\pi i \omega}{c^2} \hat{G} (\hat{\sigma} \bar{E})_y, \quad (9)$$

where $u \propto e^{ikz}$ is the solution of $(d^2/dz^2 + k^2)u = 0$ outgoing when $z \rightarrow \infty$ and it corresponds to the incident wave. The second term on the right in Eq. (9) represents the electric field radiated by the system, \hat{G} is the Green's integral operator whose kernel satisfies

$$\left[\frac{d^2}{dz^2} + k^2 \right] G(z, z') = \delta(z - z') \quad (10)$$

and obeys the Sommerfeld radiation condition. Here $\delta(x)$ is the Dirac δ function.

The solution of Eq. (10) is known to be

$$G(z, z') = e^{ik|z-z'|}/2ik. \quad (11)$$

Therefore, normalizing the amplitude of the incident wave to one, the equation to be solved is

$$\begin{aligned} E_y(z) = e^{ikz} - \frac{2\pi\omega}{kc^2} \int dz' e^{ik|z-z'|} \\ \times \int dz'' \sigma^{yy}(z', z'') E_y(z''). \end{aligned} \quad (12)$$

We solve this equation using a long-wavelength approximation by which we mean that the width l of the system is much less than $1/k$. Since for $|z|$ and/or $|z'| > l$, the conductivity $\sigma^{\mu\nu}(z, z')$ is vanishingly small, assuming that $E_y(z')$ does not vary appreciably within l , it can be taken out of the integrals yielding

$$E_y(z) \equiv e^{ikz} - \frac{2\pi\omega}{kc^2} E_y(0) \langle \langle \sigma^{yy} \rangle \rangle e^{ik|z|}, \quad (13)$$

where $E_y(0)$ can be determined directly from this same equation.

The reflection and transmission coefficients r_s and t_s are defined by

$$E_y(z) \xrightarrow{z \rightarrow \infty} e^{ikz} + r_s e^{-ikz}, \quad (14a)$$

$$E_y(z) \xrightarrow{z \rightarrow -\infty} t_s e^{ikz}. \quad (14b)$$

Therefore taking the limits $z \rightarrow \pm\infty$ in Eq. (13) we obtain

$$r_s(\theta, \omega) = -\frac{2\pi \langle \langle \sigma^{yy} \rangle \rangle / c}{\cos\theta + 2\pi \langle \langle \sigma^{yy} \rangle \rangle / c}, \quad (15a)$$

$$t_s(\theta, \omega) = \frac{\cos\theta}{\cos\theta + 2\pi \langle \langle \sigma^{yy} \rangle \rangle / c}, \quad (15b)$$

where θ is the angle of incidence given by $k = (\omega/c) \cos\theta$. For a given system $\langle \langle \sigma^{yy} \rangle \rangle$ just depends on $Q = (\omega/c) \sin\theta$ and therefore Eq. (15) gives the optical coefficients for s polarization as a function only of the frequency and the angle of incidence.

B. p polarization

In this case $\bar{E} = (E_x, 0, E_z)$ and Eq. (7) can then be written in matrix form as

$$\begin{pmatrix} \frac{\omega^2}{c^2} + \frac{\partial^2}{\partial z^2} & -iQ \\ -iQ & k^2 \end{pmatrix} \begin{pmatrix} E_x \\ E_z \end{pmatrix} = -\frac{4\pi i \omega}{c^2} \begin{pmatrix} (\hat{\sigma} \bar{E})_x \\ (\hat{\sigma} \bar{E})_z \end{pmatrix}, \quad (16)$$

which can be transformed into the following integral

equation

$$\begin{pmatrix} E_x \\ E_z \end{pmatrix} = \begin{pmatrix} u \\ U \end{pmatrix} - \frac{4\pi i \omega}{c^2} \hat{G} \begin{pmatrix} (\hat{\sigma} \bar{\mathbf{E}})_x \\ (\hat{\sigma} \bar{\mathbf{E}})_z \end{pmatrix}, \quad (17)$$

where \hat{G} is the Green's integral operator whose kernel satisfies

$$\begin{pmatrix} \frac{\omega^2}{c^2} + \frac{\partial^2}{\partial z^2} & -iQ \\ -iQ & k^2 \end{pmatrix} \begin{pmatrix} G^{xx}(z, z') & G^{xz}(z, z') \\ G^{zx}(z, z') & G^{zz}(z, z') \end{pmatrix} = \begin{pmatrix} \delta(z - z') & 0 \\ 0 & \delta(z - z') \end{pmatrix} \quad (18)$$

and the Sommerfeld radiation condition; $(u, U) = (1, -Q/K)e^{ikz}$ is the outgoing (when $z \rightarrow +\infty$) solution of Eq. (16) when the right-hand side vanishes. Equation (18) can be easily solved^{2,40} yielding

$$G^{xx}(z, z') = -\frac{ikc^2}{2\omega^2} e^{ik|z-z'|}, \quad (19a)$$

$$G^{xz}(z, z') = G^{zx}(z, z') = i\frac{Qc^2}{2\omega^2} \{ e^{ik(z-z')} \Theta(z-z') - e^{-ik(z-z')} \Theta(z'-z) \}, \quad (19b)$$

$$G^{zz}(z, z') = \frac{Q^2}{k^2} G^{xx}(z, z') + \frac{c^2}{\omega^2} \delta(z - z'), \quad (19c)$$

where $\Theta(z)$ is the Heaviside unit step function.

In order to solve Eq. (17) in the long-wavelength approximation as it was done for the *s*-polarization case, we write it in terms of the fields E_x and D_z which are the ones that we can assume to vary smoothly within the width l of the system. Then we have

$$E_x(z) = e^{ikz} - \frac{4\pi i \omega}{c^2} \left[\int dz' G^{xx}(z, z') \int dz'' \sigma^{xx}(z', z'') E_x(z'') + \int dz' G^{xz}(z, z') \int dz'' S^{zz}(z', z'') D_z(z'') \right], \quad (20a)$$

$$D_z(z) = -\frac{Q}{k} e^{ikz} - \frac{4\pi i \omega}{c^2} \left[\int dz' G^{zx}(z, z') \int dz'' \sigma^{xx}(z', z'') E_x(z'') + \frac{Q^2}{k^2} \int dz' G^{zz}(z, z') \int dz'' S^{zz}(z', z'') D_z(z'') \right], \quad (20b)$$

where

$$S^{zz}(z, z') \equiv \frac{\omega}{4\pi i} [\delta(z - z') - (\epsilon^{-1})^{zz}(z, z')] \quad (20c)$$

is the conductivity response to the displacement field. That is, the current density \vec{j} is related to \vec{D} by

$$\vec{j} = \hat{S} \vec{D}. \quad (21)$$

We define the reflection and transmission coefficients for *p* polarization by

$$E_x(z) \xrightarrow{z \rightarrow -\infty} e^{ikz} - r_p e^{-ikz}, \quad (22a)$$

$$E_x(z) \xrightarrow{z \rightarrow +\infty} t_p e^{ikz}, \quad (22b)$$

or equivalently

$$D_z(z) \xrightarrow{z \rightarrow -\infty} -\frac{Q}{k} (e^{ikz} + r_p e^{-ikz}), \quad (23a)$$

$$D_z(z) \xrightarrow{z \rightarrow -\infty} -\frac{Q}{k} t_p e^{ikz}, \quad (23b)$$

where $Q/k = \tan\theta$ (see Fig. 1).

We now solve Eq. (20) with a treatment similar to the one used in the s -polarization case and taking advantage of the symmetry of the system we obtain

$$r_p(\theta, \omega) = \frac{2\pi \cos\theta \langle \langle \sigma^{xx} \rangle \rangle / c}{1 + 2\pi \cos\theta \langle \langle \sigma^{xx} \rangle \rangle / c} - \frac{2\pi \sin^2\theta \langle \langle S^{zz} \rangle \rangle / c}{\cos\theta + 2\pi \sin^2\theta \langle \langle S^{zz} \rangle \rangle / c} , \quad (24a)$$

$$t_p(\theta, \omega) = \frac{1}{1 + 2\pi \cos\theta \langle \langle \sigma^{xx} \rangle \rangle / c} - \frac{2\pi \sin^2\theta \langle \langle S^{zz} \rangle \rangle / c}{\cos\theta + 2\pi \sin^2\theta \langle \langle S^{zz} \rangle \rangle / c} . \quad (24b)$$

The first and the second terms in the right of Eq. (24a) correspond to the amplitudes of the fields radiated by the currents induced along the x direction and z direction, respectively. These results could also be obtained directly by solving Maxwell's equations for a strictly two-dimensional sheet with surface conductivity response $\langle \langle \sigma^{xx} \rangle \rangle$ and $\langle \langle S^{zz} \rangle \rangle$.

III. LOCAL APPROXIMATIONS

In the last section we found expressions for the reflection and transmission coefficients for s and p polarization in terms of the conductivity response tensor $\sigma^{\mu\nu}$ and $S^{\mu\nu}$. In the nonlocal case the evaluation of S^{zz} [Eq. (20c)] requires the inversion of the integral operator $\hat{\epsilon}^{zz}$ which might require a major computational effort. This makes local approximations attractive; however, they might also be inaccurate. Therefore in order to evaluate the importance of analyzing reflection experiments with a nonlocal model, we generate several local approximations to the exact nonlocal conductivity tensor which will be compared below by introducing a simple microscopic model.

We define the following cases:

(i) Nonlocal (NL)

$$\sigma_{NL}^{\mu\nu}(z, z') \equiv \sigma^{\mu\nu}(z, z') . \quad (25)$$

(ii) Local anisotropic (LA)

$$\sigma_{LA}^{\mu\nu}(z, z') \equiv \langle \sigma_{NL}^{\mu\nu}(z) \rangle \delta(z - z') . \quad (26)$$

This approximation will be valid if the refracted field has a smooth variation over the nonlocality range of the conductivity tensor.

(iii) Local isotropic (LI)

$$\sigma_{LI}^{\mu\nu}(z, z') \equiv \delta^{\mu\nu} \sigma_{LA}^{xx}(z, z') . \quad (27)$$

In this local approximation we neglect the anisotropy of the conductivity tensor, that is, we consider the motion of the electrons in the z direction as if there were no surface, although the electronic density may

still vary smoothly.

(iv) Local homogeneous (LH)

$$\sigma_{LH}^{\mu\nu}(z, z') = \delta^{\mu\nu} \langle \langle \sigma^{xx} \rangle \rangle \delta(z - z') / l , \quad (28)$$

where l is the thickness of the system. This is basically McIntyre and Aspnes²⁴ model and it describes a thin slab of a local, isotropic, and homogeneous material whose conductivity is the average conductivity of the original nonlocal system.

It is easy to see that in all these local approximations $\langle \langle \sigma^{xx} \rangle \rangle$ and $\langle \langle \sigma^{yy} \rangle \rangle$ and therefore r_s and t_s [see Eq. (15)] and the first term in the right of Eq. (24) for r_p and t_p , have the same value as in the exact nonlocal case. Thus the difference among the several approximations introduced above will appear only in r_p and t_p through the quantity S^{zz} which is itself given in terms of $\langle \langle \epsilon^{-1}{}^{zz}(z) \rangle \rangle$ [see Eq. (24)]. It is precisely through the calculation of this last quantity that the different approximations to the conductivity tensor manifest themselves. For example the difference between the NL and the LA case is due to the difference between the integral of the inverse and the inverse of the integral of the dielectric tensor, that is

$$\begin{aligned} \langle \langle \epsilon_{NL}^{-1}{}^{zz}(z) \rangle \rangle &\neq 1 / \langle \langle \epsilon_{NL}^{zz}(z) \rangle \rangle \\ &= 1 / \langle \langle \epsilon_{LA}^{zz}(z) \rangle \rangle = \langle \langle \epsilon_{LA}^{-1}{}^{zz}(z) \rangle \rangle . \end{aligned} \quad (29)$$

This difference is important only in the neighborhood of the surface of a system since for a translationally invariant system $\langle \langle \epsilon_{NL}^{-1}{}^{zz}(z) \rangle \rangle = \langle \langle \epsilon_{LA}^{-1}{}^{zz}(z) \rangle \rangle$ holds. Therefore, in general the *nonlocal* effects appear in the optical coefficients as *surface* effects.

IV. MICROSCOPIC CALCULATION OF THE CONDUCTIVITY TENSOR

In this section we calculate, in the RPA, the nonlocal conductivity tensor from a simple microscopic model of a quasi-two-dimensional electron system. Our model consists of electrons which are free to move in the XY plane and are confined along the z direction by a potential

$$v(z) = -v_0 \delta(z), \quad v_0 > 0 . \quad (30)$$

The translational symmetry in the XY plane allows us to write the single-particle electronic eigenfunctions as

$$\psi_{\vec{K}, \kappa}(\vec{p}, z) = e^{i\vec{K} \cdot \vec{p}} \phi_{\kappa}(z) , \quad (31)$$

where \vec{K} and κ are the quantum numbers which specify the electronic states, \vec{K} is a two-dimensional wave vector on the XY plane, $\phi_{\kappa}(z)$ satisfies

$$\left(\frac{\hat{p}_z^2}{2m} - v_0 \delta(z) \right) \phi_{\kappa}(z) = \epsilon_{\kappa} \phi_{\kappa}(z) , \quad (32)$$

and the electronic energy is

$$E_{\bar{K}, \kappa} = \frac{\hbar^2 K^2}{2m} + \epsilon_{\kappa} . \quad (33)$$

The one-dimensional δ potential has only one bound state given by

$$\kappa = m v_0 / \hbar^2 , \quad (34a)$$

$$\epsilon_{\kappa} = -\hbar^2 \kappa^2 / 2m \equiv -\hbar \omega_0 , \quad (34b)$$

$$\phi_{\kappa}(z) = \sqrt{\kappa} e^{-\kappa z} , \quad (34c)$$

and a continuous spectrum of unbound states ($\epsilon_{\kappa} > 0$), analogous to accumulation layers spectra as calculated within the Hartree approximation.⁷

The occupied states in the system are described by $\kappa = m v_0 / \hbar^2$ and \bar{K} lying inside a circle (the Fermi cir-

cle) of radius K_F and energy less than

$$\epsilon_F = \frac{\hbar^2}{2m} (K_F^2 - \kappa^2) < 0 . \quad (35)$$

The Fermi momentum $\hbar K_F$ is related to the superficial electronic density n_0 (number of electrons per unit area) by

$$K_F^2 = 2\pi n_0 . \quad (36)$$

In Ref. 41 the conductivity tensor $\sigma_{Q, \omega}^{\mu\nu}(z, z')$ is calculated within the RPA for an electron system in which the translational symmetry along the z direction is broken by the presence of a surface. Since the radiation wave vectors we are interested in are much smaller than typical electronic wave vectors, taking the limit $Q \rightarrow 0$ we obtain (see Appendix) a diagonal nonisotropic conductivity tensor given by

$$\begin{aligned} \sigma^{\text{xx}}(z, z') = & i \frac{e^2 n(z)}{m \omega} \delta(z - z') \\ & + i \frac{n_0 e^2}{m \omega} \frac{K_F^2}{4} \left\{ \frac{\kappa}{(q - \kappa)} \left[\left(\left[1 - \frac{\kappa}{q} \right] \exp[-(\kappa + q)z_{>}] \exp[(q - \kappa)z_{<}] + \frac{\kappa}{q} \exp[-(\kappa + q)(z_{>} + z_{<})] \right) \Theta(z_{<}) \right. \right. \\ & + \exp[-(\kappa + q)(z_{>} - z_{<})] \Theta(z_{>}) \Theta(-z_{<}) \\ & + \left. \left. \left[\left[1 - \frac{\kappa}{q} \right] \exp[(\kappa - q)z_{<}] + \frac{\kappa}{q} \exp[(\kappa + q)(z_{>} + z_{<})] \right] \Theta(-z_{>}) \right\} \right. \\ & \left. + (\omega \rightarrow -\omega; \text{c.c.}) \right\} , \quad (37a) \end{aligned}$$

$$\begin{aligned} \sigma^{\text{zz}}(z, z') = & \frac{ie^2 n_0}{m \omega} \frac{1}{4} \left\{ \kappa(q - \kappa) \left[\left(\left[1 + \frac{\kappa}{q} \right] \exp[-(\kappa + q)z_{>}] \exp[(q - \kappa)z_{<}] - \frac{\kappa}{q} \exp[-(\kappa + q)(z_{>} + z_{<})] \right) \Theta(z_{<}) \right. \right. \\ & + \exp[-(\kappa + q)(z_{>} - z_{<})] \Theta(z_{>}) \Theta(-z_{<}) \\ & + \left. \left. \left[\left[1 + \frac{\kappa}{q} \right] \exp[(\kappa - q)z_{>}] \exp[(\kappa + q)z_{<}] - \frac{\kappa}{q} \exp[(\kappa + q)(z_{>} + z_{<})] \right] \Theta(-z_{>}) \right\} \right. \\ & \left. + (\omega \rightarrow -\omega; \text{c.c.}) \right\} , \quad (37b) \end{aligned}$$

where

$$\frac{\hbar^2 q^2}{2m} = -(\epsilon_{\kappa} + \hbar \omega) ,$$

$$\text{Re}(q) \geq 0, \quad \text{Im}(q) \leq 0, \quad (37c)$$

$$n(z) = n_0 \kappa e^{-2\kappa|z|} , \quad (37d)$$

$z_{>}$ and $z_{<}$ are the bigger and smaller of z and z' , respectively, and $(\omega \rightarrow -\omega; \text{c.c.})$ is a term obtained

from the previous one by changing ω to $-\omega$ and then taking the complex conjugate.

There are several points about these expressions which deserve comments. Since ϵ_{κ} is negative then q is real or imaginary depending on whether the quotient ω/ω_0 is less or greater than one, respectively, and therefore the conductivity becomes either pure imaginary or complex. In the $Q \rightarrow 0$ limit the system is able to absorb energy only through ionization. Thus if $\omega < \omega_0$ there is no ionization and the conduc-

tivity is pure imaginary (the dielectric function is real); on the other hand if $\omega > \omega_0$ the conductivity has a real part (the dielectric function has an imaginary part) and there is energy absorption.

As can be seen from Eq. (34) and Eq. (37c) q is either real and less than κ or pure imaginary, thus comparing Eqs. (37a) and (37b) with (37d) one can see that the nonlocality range of the conductivity is greater than the electronic density range $(2\kappa)^{-1}$. Therefore we expect that nonlocality will be of importance in the optical properties of our model.

V. RESULTS

In this section we present the numerical results for the conductivity and the optical coefficients for a specific choice of parameters in our model. These parameters are the strength of the potential V_0 and the number of electrons per unit area n_0 or, equivalently, the Fermi wave vector K_F and the quantum number κ . We choose K_F and κ in order to simulate a typical surface density ($n_0 \sim 10^{12} \text{ cm}^{-2}$) and width ($\sim 30 \text{ \AA}$) of an inversion or accumulation layer in a MOS structure

$$K_F = \sqrt{2\pi n_0} = 0.01 a_0^{-1}, \quad (38a)$$

$$\kappa = 1.5 K_F, \quad (38b)$$

where a_0 is Bohr's radius.

In Fig. 2 we show the reduced dimensionless conductivity $\Sigma^{zz}(0, z')$ defined as

$$\Sigma^{zz}(z, z') \equiv \sigma^{zz}(z, z') / K_F^2 \langle \langle \sigma^{xx} \rangle \rangle, \quad (39a)$$

where

$$\langle \langle \sigma^{xx} \rangle \rangle = \frac{ie^2 n_0}{m \omega} \quad (39b)$$

is the Drude conductivity obtained by integrating Eq. (37a). We also show the density profile $n(z)/K_F n_0$ which corresponds to the reduced local conductivity $\Sigma_L^{xx}(z)$ where

$$\Sigma_L^{xx}(z) \equiv \langle \sigma^{xx}(z) \rangle / K_F \langle \langle \sigma^{xx} \rangle \rangle = n(z) / K_F n_0. \quad (40)$$

It can be seen that for $\omega < \omega_0$, Σ^{zz} is real (σ^{zz} is pure imaginary) so there is no energy absorption, and for $\omega > \omega_0$, Σ^{zz} is complex. It is also seen that the electronic density of the ground state decays more rapidly than the nonlocal conductivity for both $\omega > \omega_0$ and $\omega < \omega_0$.

Now we present our results for the optical coefficients for the four cases: NL, LA, LI, and LH. As discussed above r_s depends only on $\langle \langle \sigma^{xx} \rangle \rangle = ie^2 n_0 / m \omega$ which is the same in all four cases. On the other hand in order to evaluate r_p it is necessary

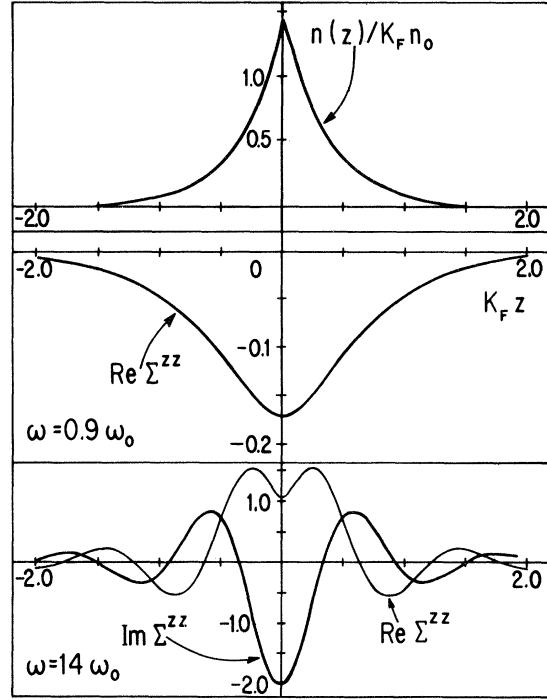

FIG. 2. The top panel shows the normalized density $n(z)/K_F n_0$ as a function of $K_F z$. The middle panel shows the real part of the reduced nonlocal conductivity $\Sigma^{zz}(0, z')$ as a function of $K_F z'$ for $\omega = 0.9 \omega_0$. At this frequency the imaginary part of $\Sigma^{zz}(0, z')$ vanishes. The bottom panel shows the real and imaginary parts of $\Sigma^{zz}(0, z')$ as a function of $K_F z'$ for $\omega = 14 \omega_0$. The $K_F z'$ scale is the same in the three panels.

to calculate

$$\langle \langle S^{zz} \rangle \rangle = \frac{\omega}{4\pi i} \int dz [1 - \langle \langle \epsilon^{-1} \rangle \rangle^{zz}(z)] \quad (41)$$

This quantity does depend on the approximation used for σ^{zz} .

In the NL case we first solve numerically, using the Gauss-Laguerre integration method,⁴² the integral equation

$$\int dz' \epsilon_{NL}^{zz}(z, z') \langle \langle \epsilon_{NL}^{-1} \rangle \rangle^{zz}(z') = 1 \quad (42)$$

for $\langle \langle \epsilon_{NL}^{-1} \rangle \rangle^{zz}(z')$ and then use this result to calculate numerically the integral in Eq. (41). In the LA case we obtain an analytical expression for

$$\langle \langle \epsilon_{LA}^{-1} \rangle \rangle^{zz}(z) = 1 / \langle \langle \epsilon_{LA}^{zz} \rangle \rangle$$

and then perform a numerical integration in Eq. (41). The other two cases are solved analytically. In order to specify the LH case completely we choose as the effective thickness of the system [Eq. (28)] twice the electronic density range $l = 1/\kappa$.

We will show, for each of the different cases presented above, the reflectance and the ellipsometric

coefficients Δ and ϕ defined by

$$\tan\phi e^{i\Delta} = r_p/r_s \quad (43)$$

When linearly polarized light at 45° is reflected, it becomes elliptically polarized; Δ measures the phase difference between the p and s components of the reflected light and ϕ measures the angle of polarization after the phase difference has been compensated.

In Fig. 3 we present the reflectance as a function of the angle of incidence for a frequency slightly lower than ω_0 . Although the reflectance of the isolated quasi-two-dimensional system is of order $(\langle\langle\sigma^{xx}\rangle\rangle/c)^2 \approx 10^{-5}$ the contribution to the reflectance of a system on a substrate will be of order $\langle\langle\sigma^{xx}\rangle\rangle/c \approx 10^{-2}$. For $\Theta \rightarrow \pi/2$ the reflectance becomes unity and for $\Theta \rightarrow 0$ it does not depend on $\langle\langle S^z \rangle\rangle$ due to the $\sin^2\theta$ factor in the second term on the right of Eq. (24a), so the different approximations give the same results at these values. However, for large angles of incidence near the principal angle of incidence there is a noticeable difference in the reflectance calculated within the different approximations. For this reason we choose an angle of incidence of 80° in the following figures.

Figure 4 shows the optical coefficients as a function of the frequency. Besides the four approximations discussed previously we also show the results for the local homogeneous case with damping (LHD) in order to compare the nonlocal effects as introduced in our model with damping effects in the relaxation time approximation. This is introduced by replacing in the LH conductivity the frequency ω by $\omega + i/\tau$ where τ is the electronic lifetime. For an inversion layer $\tau \approx 10^{-12}$ sec (Refs. 6 and 15) so we choose

$$\Gamma \equiv 1/\omega_0\tau = 10 \quad (44)$$

We can see in Fig. 4(a) a very high peak in the re-

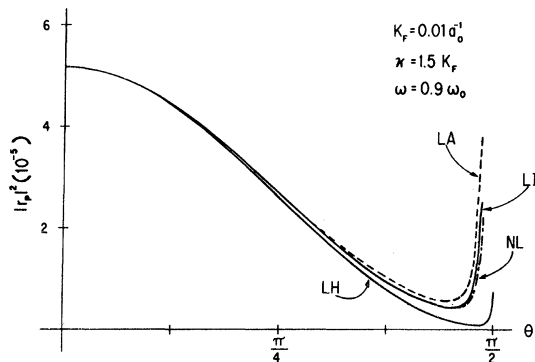

FIG. 3. Reflectance $|r_p|^2$ vs angle of incidence θ for four different cases discussed in the text.

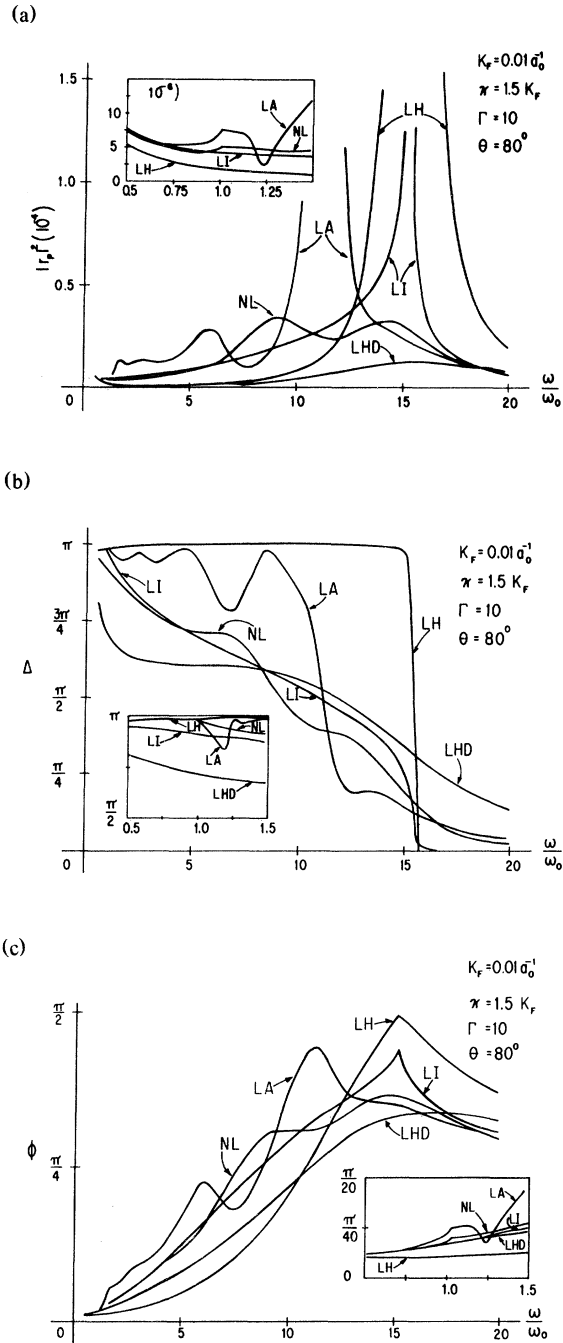

FIG. 4. (a) Reflectance $|r_p|^2$ vs the reduced frequency ω/ω_0 for five different cases discussed in the text with parameters corresponding to the inversion layer. (b) The ellipsometric coefficient Δ vs the reduced frequency ω/ω_0 for five different cases discussed in the text with parameters corresponding to the inversion layer. (c) The ellipsometric coefficient ϕ vs the reduced frequency ω/ω_0 for five different cases discussed in the text with parameters corresponding to the inversion layer.

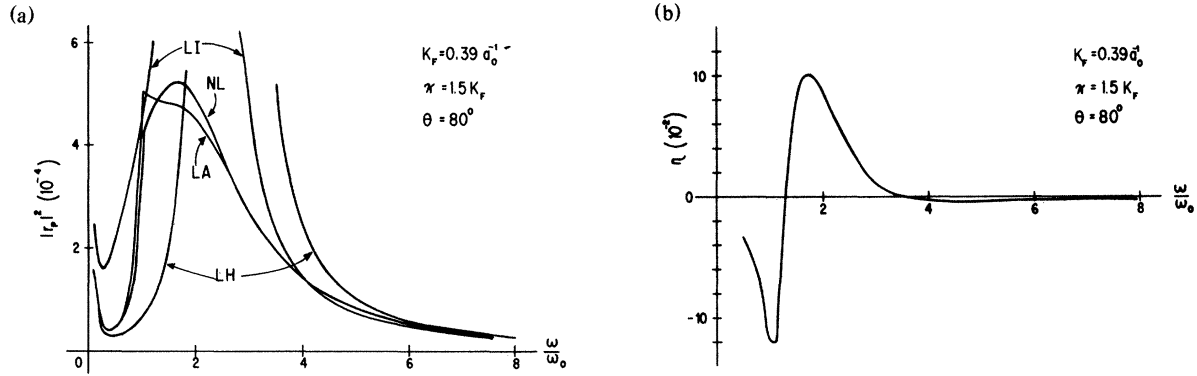

FIG. 5. (a) Reflectance $|r_p|^2$ as a function of the reduced frequency ω/ω_0 for four different cases discussed in the text with parameters corresponding to a metallic monolayer. (b) The fractional reflectance difference $\eta \equiv (|r_{p,NL}|^2 - |r_{p,LA}|^2) / \frac{1}{2}(|r_{p,NL}|^2 + |r_{p,LA}|^2)$ between the NL and LA cases discussed in the text as a function of the reduced frequency ω/ω_0 with parameters corresponding to the metallic monolayer.

reflectance at the plasma frequency

$$\omega_p = \left(\frac{4\pi n_0 \kappa e^2}{m} \right)^{1/2} = 15.3 \omega_0 \quad (45)$$

in the LH and LI cases. This peak is also present in the ellipsometric coefficient ϕ and it appears as a rapid change in the phase Δ [Figs. 4(c) and 4(b), respectively]. In the LA case the peak appears dis-

placed from the plasma frequency and it is smeared out in the NL case.

For the LI case it can be shown that there is energy absorption at frequencies below ω_p so the phase Δ varies smoothly through ω_p , as compared to the LH case in which the variation is abrupt.

Since at ω_0 electrons are excited out of the localized subband into the continuum, we see a discontinuity in the slopes of the optical-coefficient curves

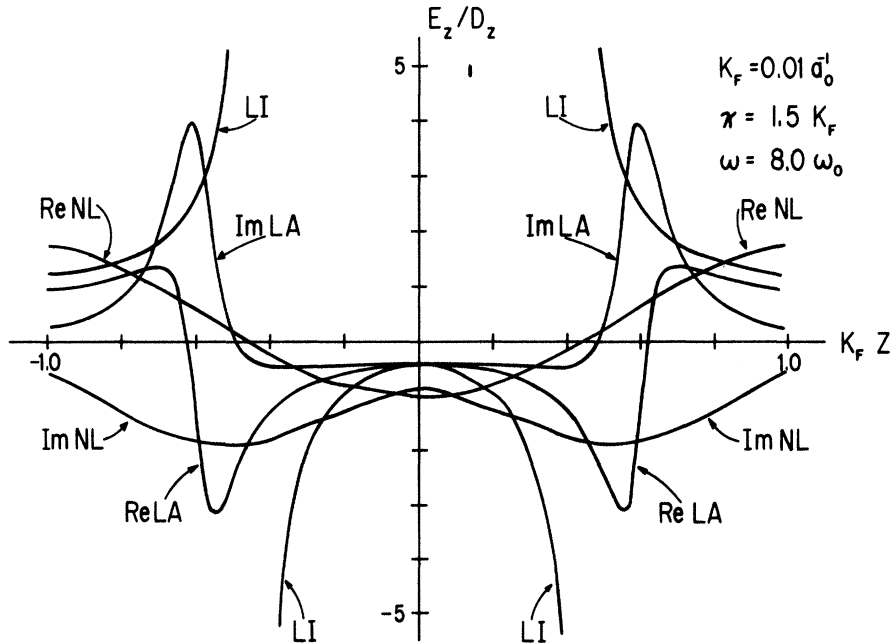

FIG. 6. Real and imaginary parts of $\langle (\epsilon^{-1})^{zz}(z) \rangle$ which in the long-wavelength approximations corresponds to $E_z(z)/D_z(0)$, as a function of $K_F z$ for the NL, LA, and LI cases discussed in the text. The parameters correspond to the inversion layer and the frequency is $8\omega_0$. In the LI case the imaginary part of $\langle (\epsilon^{-1})^{zz}(z) \rangle$ vanishes.

for the NL and LA cases (see insets of Fig. 4). This discontinuity is absent in the isotropic (LI, LH, and LHD) cases in which the electrons move freely along the z direction.

Finally, it is seen that our model predicts an appreciable difference between the optical coefficient as calculated using the nonlocal conductivity tensor and the local approximations discussed above. For the inversion layer this difference is of the same order of magnitude as the one due to the finite electronic lifetime in the LHD case.

Now we adjust the parameters of our model to simulate a free-electron-like metallic monolayer. We obtain then $K_F = 0.39a_0^{-1}$ and $\kappa = 1.46K_F$ by simply taking the surface density and work function corresponding to bulk sodium. Figure 5(a) shows the reflectance as a function of frequency. As in Fig. 4(a), there is a strong peak at the plasma frequency for both the LI and LH cases and there is a discontinuity in the slope for the NL and LA cases at ω_0 . Since ω_p is very near to ω_0 , much of the structure of Fig. 4 is lost and, as expected, all the curves coalesce into one at high frequencies. At low frequencies the LI and LH cases are poor approximations to the NL case, on the other hand the LA case remains a fairly good approximation. However, Fig. 5(b) shows that the difference between the NL and the LA reflectance can be as large as 10%.

As a by-product of our calculation we obtained the inverse dielectric function $\langle(\epsilon^{-1})^z(z)\rangle$ which is proportional to the *electric field* in the long-wavelength approximation in which D_z is constant within the width of the system. This is shown in Fig. 6 as a function of z for a frequency below ω_p . In the LI case the inverse dielectric function is real and has a pole whenever the frequency equals the local plasma frequency $\omega_p(z) = \omega_p e^{-\kappa|z|}$. This pole is responsible for the energy absorption in this case. In the LA case this pole becomes a peak at a higher value of z and the function $\langle(\epsilon^{-1})^z(z)\rangle$ acquires an imaginary part also shown in the figures. On the other hand in the NL case this peak is very much flattened.

Notice that in the NL and also the LA case the energy loss function $\text{Im}[-\langle(\epsilon^{-1})^z(z)\rangle]$ (Ref. 34) is positive for some values of z and negative for others, meaning that the electronic system can take energy from the electromagnetic field in some place and give some of it back at another place,^{26,27,34,43} clearly a nonlocal effect.

VI. CONCLUSIONS

We have derived simple closed formulas for the complex amplitude reflection and transmission coeffi-

cients in terms of appropriate averages of the conductivity responses $\hat{\sigma}$ and \hat{S} . These formulas are of very general nature and can be applied to any quasi-two-dimensional system in which the long-wavelength approximation holds. They were derived without particular assumptions as for example the separability of the conductivity.^{1,11} On the other hand they can be readily interpreted as the superposition of the fields radiated by each independent component of the electronic motion taking into account the action of these radiated fields on the system itself. The introduction of the function \hat{S} incorporates into the formalism the so-called depolarization effects.^{6,8}

The dispersion relations for the normal modes of the system are obtained from the poles of the reflection coefficients and are expressed directly in terms of its response functions. For example, for TM modes with the electronic motion restricted either to the XY plane or to the z direction, we obtain immediately from our formulas [Eqs. (15) and (24)] previously reported dispersion relations,^{1,20,23} which also reduce to the long-wavelength limit of the dispersion relation obtained by Chen *et al.*¹⁰ for a local anisotropic homogeneous system.

Here we have chosen a very simple model for a quasi-two-dimensional system which allowed us to obtain a simple expression for the nonlocal conductivity. Different approximations to this expression were done in order to perform a quantitative comparison of their corresponding optical coefficients.

Our results show that all approximations give the same values for the optical coefficients in the high-frequency range ($\omega \gg \omega_p$), but there are important differences at certain angles of incidence and at frequencies close to either ω_0 or ω_p . With respect to the spatial variation of the refracted electric field the differences between the NL case and the different local cases are even more striking. Therefore we believe that the theoretical interpretation of experimental data requires detailed nonlocal calculations.

ACKNOWLEDGMENTS

We would like to acknowledge fruitful discussions with A. Bagchi, R. Fuchs, and K. L. Kliewer about the content of this work. The technical assistance of V. Castillo is also acknowledged.

APPENDIX

Here we evaluate the conductivity tensor $\sigma_{\kappa\kappa'}^z(z, z')$ in the RPA. We consider first Eq. (4.17) of Ref. 41 for $\sigma^z(z, z')$ which we rewrite as

$$\sigma^z(z, z') = \frac{ie^2 n(z)}{m\omega} \delta(z - z') + \frac{2i}{\omega} \sum_{\kappa, \kappa'} f(E_{\kappa, \kappa'}) \left[\sum_{\kappa'} \left(\frac{j_{\kappa\kappa'}(z) j_{\kappa\kappa'}(z')}{\epsilon_{\kappa} + \hbar\omega - \epsilon_{\kappa'} + i\eta} + \frac{j_{\kappa'\kappa}(z) j_{\kappa\kappa'}(z')}{\epsilon_{\kappa} - \hbar\omega - \epsilon_{\kappa'} - i\eta} \right) \right], \quad (A1)$$

where e is the electronic charge, $n(z)$ is the electronic density, f is the zero-temperature Fermi occupation function, η is an infinitesimal positive number and we define

$$j_{\kappa\kappa'}(z) = \frac{-e\hbar}{2mi} \left[\phi_{\kappa}^*(z) \frac{\partial \phi_{\kappa'}(z)}{\partial z} - \frac{\partial \phi_{\kappa}^*(z)}{\partial z} \phi_{\kappa'}(z) \right]. \quad (\text{A2})$$

The sum over κ' in Eq. (A1) can be expressed in terms of

$$G^+(z, z'; \epsilon_{\kappa} + \hbar\omega) \equiv \sum_{\kappa'} \frac{\phi_{\kappa'}(z) \phi_{\kappa'}^*(z')}{(\epsilon_{\kappa} + \hbar\omega) - \epsilon_{\kappa'} + i\eta} \quad (\text{A3})$$

and its derivatives as

$$\begin{aligned} \sigma^{\text{xx}}(z, z') &= \frac{ie^2 n(z)}{m\omega} \delta(z - z') \\ &+ \frac{2i}{\omega} \left[\frac{e\hbar}{2mi} \right]^2 \sum_{\bar{K}, \kappa} f(E_{\bar{K}, \kappa}) \left[\left[\phi_{\kappa}^*(z) \phi_{\kappa}'(z') \frac{\partial}{\partial z} G^+(z, z'; \epsilon_{\kappa} + \hbar\omega) - \phi_{\kappa}^*(z) \phi_{\kappa}(z') \frac{\partial^2}{\partial z \partial z'} G^+(z, z'; \epsilon_{\kappa} + \hbar\omega) \right. \right. \\ &\quad \left. \left. - \phi_{\kappa}'(z) \phi_{\kappa}'(z') G^+(z, z'; \epsilon_{\kappa} + \hbar\omega) + \phi_{\kappa}'(z) \phi_{\kappa}(z') \frac{\partial}{\partial z'} G^+(z, z'; \epsilon_{\kappa} + \hbar\omega) \right] \right. \\ &\quad \left. + (\omega \rightarrow -\omega; \text{c.c.}) \right], \quad (\text{A4}) \end{aligned}$$

where ϕ_{κ}' and ϕ_{κ}^{**} are the derivatives of ϕ_{κ} and ϕ_{κ}^* and $(\omega \rightarrow -\omega; \text{c.c.})$ is a second term obtained from the previous one by changing ω to $-\omega$ and then taking the complex conjugate.

The sum over κ is trivial because there is only one value of κ below the Fermi level [Eqs. (34) and (35)]. The only factor depending on \bar{K} is the Fermi function so the sum over \bar{K} gives a factor of n_0 .

Since G^+ in Eq. (A3) is the spectral representation of the Green's operator, it satisfies

$$\left[\Omega^+ - \left(\frac{p_z^2}{2m} - v_0 \delta(z) \right) \right] G^+(z, z'; \Omega^+) = \delta(z - z') \quad (\text{A5})$$

and the Sommerfeld's radiation condition. The solution of Eq. (A5) is

$$G^+(z, z'; \Omega^+) = -\frac{2m}{\hbar^2} \frac{u(z_{>}) v(z_{<})}{w(u, v)}, \quad (\text{A6a})$$

$$\sigma^{\text{xx}}(z, z') = \frac{ie^2 n(z)}{m\omega} \delta(z - z') + i \frac{2}{\omega} \left[\frac{e\hbar}{m} \right]^2 \left[\sum_{\bar{K}, \kappa} f(\epsilon_{\bar{K}, \kappa}) (K^x)^2 \phi_{\kappa}^*(z) \phi_{\kappa}(z') G^+(z, z') + (\omega \rightarrow -\omega; \text{c.c.}) \right]. \quad (\text{A7})$$

The sum over κ is trivial and the sum over \bar{K} gives a factor of $n_0 K_F^2/8$. Substituting Eq. (A6) and the wave functions (34c) into Eq. (A7) we obtain Eq.(37a).

where

$$u(z) = e^{-qz} \Theta(z) + \left[\frac{\kappa}{q} e^{qz} + \left(1 - \frac{\kappa}{q} \right) e^{-qz} \right] \Theta(-z), \quad (\text{A6b})$$

$$v(z) = \left[\left(1 - \frac{\kappa}{q} \right) e^{qz} + \frac{\kappa}{q} e^{-qz} \right] \Theta(z) + e^{qz} \Theta(-z), \quad (\text{A6c})$$

$$w(u, v) = 2(q - \kappa) \quad (\text{A6d})$$

is the Wronskian,

$$\frac{\hbar^2 q^2}{2m} = -\Omega^+ \quad (\text{A6e})$$

with

$$\text{Re}(q) \geq 0 \text{ and } \text{Im}(q) \leq 0,$$

and $z_{>}$ and $z_{<}$ are the bigger and smaller between z and z' respectively. Now, substituting Eq. (A6) and the wave functions (34c) into Eq. (A4) we find the desired result Eq. (37b).

By a completely similar method, from Eq. (4.13) of Ref. 41, we arrive at the following equation for

- ¹J. E. Sipe, *Surf. Sci.* **84**, 75 (1979).
²A. Bagchi, R. G. Barrera, and A. K. Rajagopal, *Phys. Rev. B* **20**, 4824 (1979).
³R. G. Barrera and A. Bagchi, *Phys. Rev. B* **20**, 3186 (1979).
⁴*MOS Integrated Circuits*, edited by W. M. Penney and L. Lau (Van Nostrand Reinhold, New York, 1972), p. 49.
⁵D. A. Dahl and L. J. Sham, *Phys. Rev. B* **16**, 651 (1977).
⁶S. J. Allen, D. C. Tsui, and B. Vinter, *Solid State Commun.* **20**, 425 (1976).
⁷T. Ando, *Phys. Rev. B* **13**, 3468 (1976).
⁸T. Ando, *Solid State Commun.* **21**, 133 (1977).
⁹A. V. Chaplik, *Sov. Phys. JETP* **33**, 997 (1971) [*Zh. Eksp. Teor. Fiz.* **62**, 746 (1971)].
¹⁰W. P. Chen, Y. J. Chen, and E. Burstein, *Surf. Sci.* **58**, 263 (1976).
¹¹A. Eguluz and A. A. Maradudin, *Ann. Phys. (N.Y.)* **113**, 29 (1978).
¹²F. Stern and W. E. Howard, *Phys. Rev.* **163**, 816 (1969).
¹³F. Stern, *Phys. Rev. B* **5**, 4891 (1972).
¹⁴F. Stern, *Phys. Rev. Lett.* **30**, 278 (1973).
¹⁵P. Kneschaurek, A. Kamgar, and J. F. Koch, *Phys. Rev. B* **14**, 1610 (1976).
¹⁶B. D. McCombe, R. T. Holm, and D. E. Schafer, *Solid State Commun.* **32**, 603 (1979).
¹⁷J. J. Quinn, *Rev. Mex. Fís.* **26**, 155 (1979).
¹⁸L. Bonsall and A. A. Maradudin, *Phys. Rev. B* **15**, 1959 (1979).
¹⁹H. J. Simon, E. E. Mitchel, and J. G. Watson, *Am. J. Phys.* **43**, 630 (1975).
²⁰M. Nakayama, *J. Phys. Soc. Jpn.* **36**, 393 (1974).
²¹M. Cardona, *Am. J. Phys.* **39**, 1277 (1971).
²²B. Dasgupta and A. Bagchi, *Phys. Rev. B* **19**, 4935 (1979).
²³M. Nakayama, *J. Phys. Soc. Jpn.* **39**, 265 (1975).
²⁴J. D. E. McIntyre and D. E. Aspnes, *Surf. Sci.* **24**, 417 (1971).
²⁵A. A. Maradudin and D. L. Mills, *Phys. Rev. B* **7**, 2787 (1973).
²⁶F. Forstmann and H. Stenschke, *Phys. Rev. Lett.* **38**, 1365 (1977).
²⁷F. Forstmann, *Z. Phys.* **32**, 385 (1979).
²⁸P. Halevi and R. Fuchs (unpublished).
²⁹A. R. Melnyk and M. J. Harrison, *Phys. Rev. B* **2**, 835 (1970).
³⁰A. R. Melnyk and M. J. Harrison, *Phys. Rev. B* **2**, 851 (1970).
³¹K. L. Kliewer and R. Fuchs, *Phys. Rev.* **172**, 607 (1968).
³²K. L. Kliewer and R. Fuchs, *Phys. Rev. B* **2**, 2923 (1970).
³³J. M. Keller, R. Fuchs, and K. L. Kliewer, *Phys. Rev. B* **12**, 2012 (1975).
³⁴K. L. Kliewer, *Phys. Rev. B* **14**, 1412 (1976).
³⁵G. Mukhopadhyay and S. Lundquist, *Solid State Commun.* **21**, 629 (1977); *Phys. Scr.* **17**, 69 (1978).
³⁶P. Apell, *Phys. Scr.* **17**, 535 (1978).
³⁷P. J. Feibelman, *Phys. Rev. B* **12**, 1319 (1975).
³⁸P. J. Feibelman, *Phys. Rev. B* **14**, 762 (1976).
³⁹E. Hecht and A. Zajac, *Optics* (Addison-Wesley, Reading, Mass., 1974), p. 312.
⁴⁰A. A. Maradudin and D. L. Mills, *Phys. Rev. B* **11**, 1392 (1975).
⁴¹A. Bagchi, *Phys. Rev. B* **15**, 3060 (1977).
⁴²M. Abramowitz and I. A. Stegun, *Handbook of Mathematical Functions* (Dover, New York, 1965).
⁴³K. L. Kliewer, *Phys. Rev. Lett.* **33**, 900 (1974).