

Defects and the central peak near structural phase transitions

B. I. Halperin* and C. M. Varma

Bell Laboratories, Murray Hill, New Jersey 07974

(Received 15 December 1975)

The effect of defect or impurities on the static and dynamic response, near a displacive structural phase transition, depends on the symmetry and dynamics of the defect cell. It is shown that a small concentration of defect cells, in which the order parameter relaxes on a slow time scale between different equivalent orientations, may account for the narrow "central peak" as well as for the temperature dependence of the "soft-mode" frequency in the perovskites near structural phase transitions. The case of a frozen defect cell is also discussed. Calculations are performed for the pure and impure systems using mean-field theory, and corrections are discussed using the universality hypotheses and renormalization-group calculations for dynamic critical behavior.

I. INTRODUCTION

According to the simplest mean-field approximation, a second-order displacive phase transition is always associated with a "soft phonon mode" of appropriate symmetry, i.e., a phonon whose frequency goes to zero $\propto (T - T_c)^{1/2}$, as the temperature T approaches the transition from above.¹⁻⁵ A slightly more sophisticated analysis, which takes damping into account, would suggest that the phonon becomes overdamped for T slightly above T_c , so that the spectrum revealed by inelastic neutron or light scattering would show a single peak close to T_c , whose width continues to decrease as $T \rightarrow T_c$.³ Experiments on a variety of materials are in marked contrast to this picture, however, as they show the existence of a very narrow central peak *in addition* to the soft phonon modes. In SrTiO₃, for example, a central peak has been observed⁶⁻⁸ as far as 65 K above the transition temperature $T_c \approx 100$ K. As $T \rightarrow T_c$, the weight of the central peak grows relative to that of the phonon peaks, so that for $T - T_c \lesssim 10$ K the majority of the total weight is in the central mode. In fact, the weight in the phonon peaks, as well as the phonon frequency, remains finite as $T \rightarrow T_c$, whereas the central-peak weight diverges. Qualitatively similar behavior has been observed in a number of other perovskites, including LaAlO₃,⁹ and KMnF₃.¹⁰ Central peaks observed in a variety of other materials, including KH₂PO₄ (KDP),¹¹ and Nb₃Sn,¹² also resemble those in the perovskites.

One of the most important facts about the central peak in SrTiO₃ (and other materials), that any theory must explain, is its extreme narrowness. Even at the highest temperature observed, the width was unresolvable in the neutron measurements.⁶⁻⁸ Indirect measurements by Müller *et al.*,¹³ via the EPR linewidth of a Fe³⁺ oxygen-vacancy complex, suggested that the central peak

has a finite linewidth corresponding to a relaxation rate Γ_{Q_0} of order $0.6 \times 10^8 \text{ sec}^{-1}$, at $T_c + 2$ K. Very recently, direct measurements using neutron scattering with very high resolution have been published by Töpler *et al.*,¹⁴ which give a somewhat larger linewidth of 6×10^{-7} eV (full width at half-maximum), corresponding to a relaxation rate $4.5 \times 10^8 \text{ sec}^{-1}$, at $T_c + 4$ K. This number is reportedly consistent with independent measurements by Mezei and Hayter¹⁵ using the technique of spin-echo neutron scattering. However, measurements by Darlington *et al.*¹⁶ of Mössbauer γ rays scattered by the central peak indicate that the relaxation rate is smaller than $0.6 \times 10^8 \text{ sec}^{-1}$, for $T \leq T_c + 6$ K. We remark that the various estimates of the central-peak width are three to four orders of magnitude smaller than the width or the energy of the soft phonon mode, measured by Axe *et al.*⁸

Several theoretical calculations have been carried out, which have predicted the simultaneous existence of a central peak and soft phonon modes in certain models.¹⁷⁻²⁷ (See discussion in Sec. VII B below.) However, none of these calculations has reproduced the observed characteristic that the width of the central peak is very narrow compared to the phonon widths, even at temperatures well above T_c , where the *weight* in the central peak is small compared to that in the phonon peak.²⁸ Indeed, it seems to us to be very difficult to imagine a model where this feature is reproduced, unless some extrinsic mechanism is introduced to give a frequency scale very small compared to the intrinsic phonon frequencies. Consequently, one is led to explore the possibility that the central mode may be due to the presence of impurities or other defects.

Impurities were considered by Axe, Shapiro, Shirane, and Riste,^{8,23} who pointed out that the existence of an infinitely narrow central peak

could be explained by scattering from the temperature-dependent static strain field surrounding an impurity, if the impurity is located in a position whose symmetry allows it to couple linearly to the soft mode. (See also comments in Ref. 23.) It has often been assumed that an explanation dependent on impurities or defects would be inconsistent with a finite linewidth for the central peak, such as that indicated by the EPR measurements. The purpose of the present paper is to point out that one should also consider a model in which the distortion in a defective unit cell may hop back and forth between positions which break the symmetry in opposite senses, a situation which we describe as a *relaxing defect cell*. This will lead to a central peak whose width is determined by the time scale of the hopping process, which might be of the order of 10^9 sec^{-1} if the barrier to be surmounted is of the order of $10k_B T_c$ ($\approx 0.1 \text{ eV}$ in SrTiO_3). We have constructed a simple mean-field-theory solution of such a model, which demonstrates many of the features of experiments on SrTiO_3 . Our results are similar in form to those of the phenomenological equations^{8,12,29} which are most commonly used to parametrize observations of central peaks. Furthermore, the concentration of defects necessary to account for the observed effects is estimated to be quite small—perhaps as small as 10^{-5} .

It is worthwhile to recall, at this point, the difference between a displacive transition, which is the primary concern of this paper, and the case of an order-disorder transition, where the order parameter involves the reorientation of a molecule.³⁰ The latter description is applicable, for example, for the orientational transitions in the ammonium halides.³¹

A mean-field theory of the order-disorder transition has been worked out by Yamada, Takatera, and Huber.³² When the molecular reorientations occur at an intrinsic rate which is very slow compared to the phonon frequencies, the theory naturally predicts a central peak in the neutron scattering, due to the orientational disorder. In contrast to the experimental observations in SrTiO_3 , however, the theory does not predict a marked softening of any of the phonon frequencies in the order-disorder case. Also, since the atomic displacements involved in a molecular reorientation are likely to be large compared to the thermal motions in the phonon modes, one would expect the integrated neutron scattering in the central peak to be large compared to the weight in the phonon modes, even at temperatures several times the transition temperature. Again, this contrasts with the neutron measurements in SrTiO_3 . According to the theory presented below, however,

it will be seen that the presence of defects of the appropriate type may give some of the characteristics of a slow orientational transition, in the vicinity of T_c , to a system that would otherwise show the displacive behavior.

The situation in crystals of the KDP type is different from that of the ammonium-halide type, since in KDP the quantum-mechanical tunneling of the protons introduces an energy splitting comparable to (but less than) the dipole-dipole interactions that tend to order the proton. This situation is usually represented³³ by an Ising model in a transverse field. In mean-field theory such a model has only a soft mode and no central peak. More realistic models³⁴ for KDP couple the tunneling motion to the other modes of vibration in the crystal and obtain a central peak through piezoelectric couplings. But as Cummins³⁵ has emphasized, the observed central peak in KDP is also much too narrow to be thus explained. Hence defects are probably also necessary to explain the observations in this case. The calculations we present in Sec. II are probably relevant also to KDP since a soft acoustic mode plays a crucial role in the actual structural transition.

In Secs. II and III, we describe a simple model for the relaxing defect cell and calculate the neutron scattering line shape in a simple mean-field approximation. These results are compared with experiments on SrTiO_3 and related compounds in Sec. IV. In Sec. V we investigate a model with frozen defect cells, which is mathematically more complicated, and rather less likely to be relevant to experiments. A more complete classification of different types of impurities is presented in Appendix A. In Sec. VI we return to the “relaxing” case and discuss the modifications of the previous results when one attempts to go beyond the mean-field theory. We also discuss the dynamics of the pure system in that section, using the ideas of universality and the renormalization-group analyses for dynamic critical phenomena. We argue that a *very narrow* central peak is unlikely to occur in any simple model of a displacive transition in a pure system.

II. MODEL FOR RELAXING DEFECT CELL

To illustrate our ideas, we shall consider here a simplified model containing impurities or defects of a type that we describe as *relaxing defect cells*. (More particularly these are impurities of type *B1b*, according to the classification of Appendix A below.)

We consider a model in which the atomic displacements responsible for the phase transition are described by a single scalar quantity ψ_i , for

each unit cell i . We suppose that any unit cell may contain a defect with probability c , or be normal, with probability $1 - c$. We consider the following classical Hamiltonian:

$$\mathcal{H} = \sum_i \left[\frac{1}{2} a_i \dot{\psi}_i^2 + \frac{1}{4} b \psi_i^4 + \frac{m}{2} \left(\frac{d\psi_i}{dt} \right)^2 - h_i \psi_i \right] - \frac{1}{2} \sum_{i,j} J_{ij} \psi_i \psi_j, \quad (2.1)$$

where h_i is an external field and m is an effective mass. The parameter a_i can take on two possible values,

$$\begin{aligned} a_i &= a_n > 0 & \text{if } i \text{ is a normal cell,} \\ a_i &= a_d < 0 & \text{if } i \text{ is defective.} \end{aligned} \quad (2.2)$$

For simplicity we assume that the mass m and the quartic coefficient b are the same for normal and defective cells, and that the coupling J_{ij} , which depends on $\vec{r}_i - \vec{r}_j$, the difference in the positions of cells i and j , does not depend on whether the cells are normal or defective.

Let us define the Fourier transform

$$J(\vec{Q}) = \sum_j J_{ij} e^{i\vec{Q} \cdot (\vec{r}_i - \vec{r}_j)}. \quad (2.3)$$

Suppose that the maximum value of $J(Q)$ occurs at a wave vector $Q = Q_0$, and set

$$J_0 = J(Q_0). \quad (2.4)$$

In order for the pure material to have broken symmetry at $T = 0$, we must have

$$a_n - J_0 < 0. \quad (2.5a)$$

We shall further assume that

$$|a_n - J_0| \ll a_n, \quad (2.5b)$$

as is appropriate for transition in the "displacive limit."³⁰ We shall see below that the pure material has its phase transition at a temperature T_c^0 of order $a_n(J_0 - a_n)/3b$.

If one neglects the coupling of a defect cell to its neighbors, then the defect cell is characterized by a double-well potential, with minima at

$$\psi_i = \pm C_d \equiv \pm (|a_d|/b)^{1/2}. \quad (2.6)$$

In order for ψ_i to pass from one well to the other, it must surmount a barrier

$$\Delta = \frac{1}{4} a_d^2 / b. \quad (2.7)$$

We shall choose $\Delta/T_c \gg 1$, so that the parameters of the defect cell are in the range appropriate for a slow orientational transition, rather than a displacive transition. This condition will be fulfilled if

$$a_d^2 \gg a_n(J_0 - a_n). \quad (2.8)$$

Let us define the local field on cell i as

$$H_i = h_i + \sum_j J_{ij} \psi_j. \quad (2.9)$$

For the normal cells, we shall assume an equation of motion of the form

$$m \frac{d^2 \psi_i}{dt^2} = H_i - a_n \psi_i - b \psi_i^3 - \gamma \frac{d\psi_i}{dt} + \eta_i, \quad (2.10)$$

where γ is a phenomenological damping constant, which is intended to describe the effects of the coupling of ψ_i to other degrees of freedom of the lattice (the thermal reservoir), and η_i is the associated Langevin noise,

$$\langle \eta_i(t) \eta_i(t') \rangle = 2\gamma T \delta(t - t'). \quad (2.11)$$

For the defective cells, we shall be concerned with the rate at which ψ_i makes transitions between the two wells at $\pm C_d$. (Oscillations within a given well will occur at a high frequency and will be relatively small in amplitude; such oscillations need not concern us here.) We write for the transition rate from ψ_i to $-\psi_i$

$$w_i = \nu e^{-H_i \psi_i / T}, \quad (2.12)$$

$$\nu \equiv \nu_0 e^{-\Delta / T}, \quad (2.13)$$

where $\psi_i = \pm C_d$ and the attempt frequency ν_0 is expected to be of the order of 10^{13} sec^{-1} . (Note that the field H_i changes the barrier for hopping by the amount $H_i \psi_i$.)

III. MEAN-FIELD APPROXIMATION

Let us examine the linear response of our system to a time-dependent applied field

$$h_i = h e^{i(\vec{Q} \cdot \vec{r}_i - \omega t)} \quad (3.1)$$

We consider the case $T > T_c$, so that $\langle \psi_i \rangle$ is zero in equilibrium. In the presence of h_i we may write

$$\begin{aligned} \langle \psi_i \rangle &= \Psi_n e^{i(\vec{Q} \cdot \vec{r}_i - \omega t)} & \text{if } i \text{ is normal,} \\ \langle \psi_i \rangle &= \Psi_d e^{i(\vec{Q} \cdot \vec{r}_i - \omega t)} & \text{if } i \text{ is defective,} \end{aligned} \quad (3.2)$$

where the angular brackets $\langle \cdot \cdot \rangle$ imply an average over thermal fluctuations at all sites and an average over the impurity distribution at sites *other than* i . In the equations of motion (2.10) and (2.12), we now make a mean-field approximation—we replace H_i by its expectation value

$$\begin{aligned} H_i - \langle \langle H_i \rangle \rangle &= h_i + \left\langle \left\langle \sum_j J_{ij} \psi_j \right\rangle \right\rangle \\ &= \{ h + [c \Psi_d + (1 - c) \Psi_n] J(Q) \} e^{i(\vec{Q} \cdot \vec{r}_i - \omega t)}. \end{aligned} \quad (3.3)$$

Here the double brackets refer to an average over the impurity distribution on *all* sites, including i

and j . In (2.10) we linearize using a Gaussian approximation,

$$a_n \psi_i + b \psi_i^3 - x_n \psi_i, \quad (3.4)$$

where

$$\begin{aligned} x_n &\approx a_n + 3b \langle \psi_i^2 \rangle \equiv a_n + 3b\sigma, \\ \sigma &\approx T/(a_n + 3b\sigma). \end{aligned} \quad (3.5)$$

We therefore have for normal sites,

$$(-\omega^2 m - i\gamma\omega + x_n) \langle \psi_i \rangle = \langle \langle H_i \rangle \rangle. \quad (3.6)$$

$$[\chi(Q, \omega)]^{-1} = \begin{pmatrix} -\omega^2 m - i\omega\gamma + x_n - (1-c)J(Q) & -cJ(Q) \\ -(1-c)J(Q) & -i\omega x_d \nu^{-1} + x_d - cJ(Q) \end{pmatrix}. \quad (3.10)$$

In the approximations made above we have averaged over the impurity configurations by introducing, in effect, a two-component displacement field at each cell—one due to the normal cells and the other due to the defective cells. These are very similar to the approximations made by Walker for the spin-wave spectrum of a mixed-crystal antiferromagnet ($\text{RbMn}_{1-x}\text{Ni}_x\text{F}_3$), where they yielded excellent results.³⁶ The approximation is qualitatively similar to the “average T -matrix approximation” in the theory of random systems.³⁷

Inelastic neutron scattering measures the dynamic structure factor

$$S(Q, \omega) = (2T/\omega) \text{Im} \bar{\chi}(Q, \omega), \quad (3.11)$$

$$\begin{aligned} \bar{\chi}(Q, \omega) &\equiv (1-c)\chi_{mm} + (1-c)\lambda\chi_{nd} \\ &\quad + c\lambda\chi_{dn} + c\lambda^2\chi_{dd}, \end{aligned} \quad (3.12)$$

where λ is the ratio of the neutron form factors in the normal and defective cells. (We shall set $\lambda = 1$ for simplicity.) The form factor $S(Q)$ measured by a quasielastic scattering experiment is related to the static susceptibility $\bar{\chi}_s(Q) \equiv \bar{\chi}(Q, \omega = 0)$, by

$$S(Q) = \int S(Q, \omega) \frac{d\omega}{2\pi} = T \bar{\chi}_s(Q). \quad (3.13)$$

The phase transition occurs when the static response $\bar{\chi}_s(Q_0)$ diverges, or

$$c/x_d + (1-c)/x_n = 1/J_0, \quad (3.14)$$

where $J_0 \equiv J(Q_0)$. For small concentrations c , this gives

$$T_c = T_c^0 + c \frac{dT_c}{dc} + \dots, \quad (3.15)$$

where

$$T_c^0 \approx J_0(J_0 - a_n)/3b, \quad (3.16)$$

For defective sites, we have for the linear response

$$x_d \nu^{-1} (-i\omega + \nu) \langle \psi_i \rangle = \langle \langle H_i \rangle \rangle, \quad (3.7)$$

$$x_d = T/C_d^2 \ll x_n. \quad (3.8)$$

By using (3.3) we may write the solution of Eqs. (3.6) and (3.7) in the form

$$\Psi_n = (\chi_{nm} + \chi_{nd})h, \quad (3.9a)$$

$$\Psi_d = (\chi_{dn} + \chi_{dd})h, \quad (3.9b)$$

where the 2×2 matrix χ is defined by

$$\frac{dT_c}{dc} \approx \frac{x_n(x_n - x_d)}{x_d x_n'} , \quad (3.17)$$

$$x_n' = \left. \frac{dx_n}{dT} \right|_{T_c^0} = \frac{3b}{2J_0 - a_n}. \quad (3.18)$$

In view of the inequalities (2.5), (2.8), and (3.8) we have

$$\frac{dT_c}{dc} \approx 3T_c^0 \frac{a_n |a_d|}{(J_0 - a_n)^2}, \quad (3.19)$$

which is positive and large compared to T_c^0 .

For T near T_c , and Q near Q_0 , we have

$$\begin{aligned} \bar{\chi}_s(Q) &= \frac{(1-c)x_d + cx_n}{x_d x_n - cx_n J(Q) - (1-c)x_d J(Q)} \\ &\approx 1/[x_n'(T - T_c) + gq^2], \end{aligned} \quad (3.20)$$

where

$$\vec{q} = \vec{Q} - \vec{Q}_0, \quad (3.21)$$

$$J(Q) \approx J_0 - gq^2, \quad (3.22)$$

and x_n' is given by (3.18). This predicts that the quasielastic neutron scattering diverges near T_c with the standard Ornstein-Zernike form

In the limit $\nu \rightarrow 0$, with ω finite, we have

$$\bar{\chi}(Q, \omega) = \frac{1-c}{m\omega^2 - i\gamma\omega + x_n - (1-c)J(Q)}. \quad (3.23)$$

The right-hand side of (3.23) has poles at the “damped phonon frequencies”

$$\omega_p^\pm = -i\gamma/2m \pm (\Omega_p^2 - \gamma^2/4m^2)^{1/2}, \quad (3.24)$$

where

$$\begin{aligned} m\Omega_p^2 &= x_n - (1-c)J(Q) \\ &\approx gq^2 + x_n'(T - T_c + cT'), \end{aligned} \quad (3.25)$$

$$T' \equiv x_n J_0 / x_d x_n'. \quad (3.26)$$

Note that Ω_p remains finite at T_c . We may also

note that T' is approximately equal to dT_c/dc , given by (3.17), so that $T_c - cT'$ is close to the transition temperature T_c^0 of the pure system. It is easy to check that the phonon contribution to $S(Q, \omega)$, obtained by insertion of (3.23) in (3.11), has total weight

$$S_p(Q) = T \bar{\chi}_p(Q) = T(1-c)/m\Omega_p^2, \quad (3.27)$$

which remains finite at T_c . If the damping $\gamma/2m$ is small compared to Ω_p , the phonon contribution is found to consist of two Lorentzian peaks, centered at $\omega = \pm \Omega_p$, with half-widths equal to $\gamma/2m$. If $\Omega_p \ll \gamma/2m$ the phonons are overdamped; a single phonon peak is then seen which nonetheless retains a finite width at T_c .

The difference between (3.27) and (3.13) is made up by a narrow Lorentzian central peak, whose half-width Γ_Q is given by

$$\Gamma_Q \equiv \nu \left(1 - \frac{cJ(Q)x_n}{x_d[x_n - (1-c)J(Q)]} \right) \approx \nu \frac{gq^2 + x'_n(T - T_c)}{gq^2 + x'_n(T - T_c + cT')}. \quad (3.28)$$

[Note that $-i\Gamma_Q$ and ω_p^* are the three roots found by setting the determinant of (3.10) equal to zero.]

For $T - T_c \gg cT'$, we may write the weight of the central peak as

$$S(Q) - S_p(Q) \approx cC_d^2 [\bar{\chi}_s(Q)]^2 J_0 x_n. \quad (3.29)$$

The mean-field theory that we have carried out for $T > T_c$ can easily be repeated below T_c . The principal change is that $T - T_c$ is everywhere replaced by $2(T_c - T)$ in formulas (3.20), (3.25), and (3.28). Equation (3.27) applies as is. Thus we have also below T_c a narrow central peak whose intensity diverges as $T \rightarrow T_c$, $Q \rightarrow Q_0$, and a damped phonon contribution to $S(Q, \omega)$ whose intensity and width remain finite. In addition, there will be an elastic Bragg peak, which only exists at $Q = Q_0$, and elastic Rayleigh scattering, at finite values of $q = Q - Q_0$. This last effect arises from variations in $\langle \psi \rangle$ due to local variations in the density of impurities. For a random distribution of impurities, the Rayleigh scattering is given, for small q , by the formula

$$S_R(Q) = c \left(\frac{d\langle \psi \rangle}{dT} \frac{dT_c}{dc} \right)^2 \approx T \bar{\chi}_s(Q) \frac{c}{T_c} \frac{dT_c}{dc} \frac{3x_n}{2x_d}. \quad (3.30)$$

This scattering is in addition to the phonon scattering and the central peak described above, whose combined weight remains equal to $T \bar{\chi}_s(Q)$. Although $S_R/T \bar{\chi}_s$ is proportional to the concentration of impurities, the remaining factors are quite large, and we estimate that the Rayleigh scattering

below T_c may be comparable to or even larger than $T \bar{\chi}_s$ for the parameters appropriate to SrTiO₃.

In the following comparison with experiment, however, we shall concentrate on $T > T_c$.

A schematic plot of $[S(Q)]^{-1}$ and $[S_p(Q)]^{-1}$, for a system with relaxing defect cells, is shown in Fig. 1.

IV. FIT TO EXPERIMENTS IN PEROVSKITES

We have already seen from the previous discussions that our simple model reproduces the qualitative features of SrTiO₃. We shall now examine this somewhat more closely. In particular, we shall see that the neutron data in SrTiO₃ can be fit by our model with a reasonable choice of the model parameters, and we can estimate the concentration of defects necessary to explain the central peak.

Experimental results in SrTiO₃ and other materials have been rather well parametrized by the phenomenological equations^{8,12,29}

$$S(Q, \omega) \propto (1/\omega) \text{Im}[\omega_0^2 - \omega^2 - i\omega\Gamma(\omega)]^{-1}, \quad (4.1)$$

where

$$\Gamma(\omega) = \Gamma_0 + \delta^2/(\nu - i\omega). \quad (4.2)$$

These equations lead to a narrow central peak, if ν is sufficiently small. In fact, these equations coincide with our mean-field results if we identify ν with the hopping rate (2.13), and

$$\omega_0^2 = m^{-1} [gq^2 + x'_n(T - T_c)], \quad (4.3)$$

$$\Gamma_0 = m^{-1} \gamma, \quad (4.4)$$

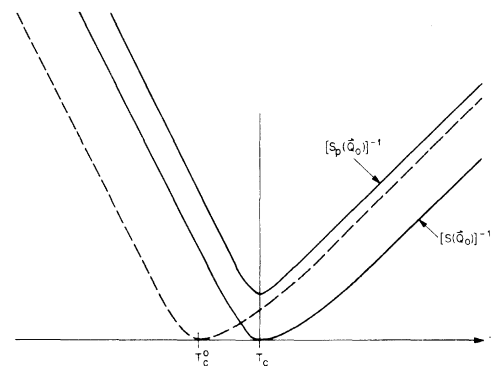

FIG. 1. Schematic plot of the inverse of the total form factor $S(Q_0)$ and of the finite-frequency "phonon" contribution $S_p(Q_0)$, for a system with "relaxing defect cells," of type 1b. The contributions of the Bragg peak and of the elastic Rayleigh scattering below T_c have been omitted from $S(Q_0)$. The dashed curve indicates $[S(Q_0)]^{-1}$ for the pure system. Deviations from straight-line behavior arise from corrections to mean-field theory.

and

$$\delta^2 = cx_n J_0 / mx_d . \quad (4.5)$$

We shall next fit the parameters entering the mean-field theory to measurements on SrTiO₃. For this purpose we shall describe the displacements in cell i by a single scalar order parameter ψ_i , which represents a cooperative displacement of two oxygen atoms per unit cell, in the directions indicated in Fig. 2. We shall neglect the competing fluctuations in the other two planes, as well as the other vibrational degrees of freedom of the system.

We first need to evaluate the three parameters a_n , b , and $J_0 - a_n$ that enter the description of the pure system. We use experimental values for $T_c \approx 110$ K, for $d(\Omega_p^2)/dT \approx 20$ K, in the mean-field region above T_c ,⁵⁻⁸ and for the zero-temperature rotation³⁸ of the TiO₆ octahedra $\approx 2^\circ$, together with the theoretical relations (3.16), (3.25), and

$$\langle \psi_i \rangle^2 |_{T=0} = (J_0 - a_n) / b . \quad (4.6)$$

[In deriving (4.6), we have simply minimized (2.1), neglecting the zero-point fluctuations of ψ_i .] We shall measure the displacement ψ in radians, so that m has dimensions of a moment of inertia. We take the inertial mass associated with the soft

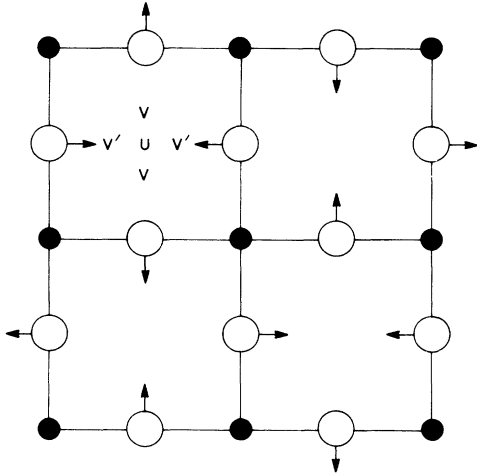

FIG. 2. Atomic positions in a (100) plane of SrTiO₃ containing Ti (filled circles) and O atoms (open circles), for $T > T_c$. Strontium atoms and additional oxygens lie between these planes and are not shown. Arrows indicate displacement of oxygens for one of the six possible orientations of the low-temperature phase. [Other possible orientations are the reverse of the indicated displacements and corresponding displacements, and the corresponding displacements in the (010) or (001) planes.] An interstitial impurity at site V or V' would either favor the indicated distortion or its reverse. An interstitial at site U , however, would not couple linearly to any of the possible distortions.

mode to be equal to that of two oxygen atoms, and we use the Ti-O distance of 1.95 Å. Our results are $a_n \approx 2.7 \times 10^5$ K/rad², $b \approx 4.6 \times 10^6$ K/rad⁴, and $J_0 - a \approx 5.5 \times 10^3$ K/rad². With these values we find

$$\delta^2 \approx 3.2 \times 10^5 c \alpha^2 (T_c / T) \times \{1 + 2 \times 10^{-2} [(T - T_c) / T_c]\} \text{ K}^2 , \quad (4.7)$$

where α is the ratio of C_d , the displacement in the defect cells, to the normal zero-temperature displacement of 2° .

The value $\delta \approx 10$ K, for SrTiO₃ has been extracted by Axe, Shapiro, Shirane, and Riste⁵⁻⁸ from their results on the temperature dependence of the intensity of the central peak and also from the temperature dependence of the soft-mode frequency. Thus we get agreement with experiment if $c \alpha^2 \approx 3.1 \times 10^{-4}$. Comparing (2.6), (2.7), and (4.6), we find that in order to get a barrier Δ of 0.1 eV between alternate positions of the order parameters in the defect cells, which would lead to a central-peak width of order 10^9 sec⁻¹, we need $\alpha \approx 5.1$. We are thus led to estimate the defect concentration in SrTiO₃ as

$$c \approx 1.2 \times 10^{-5} . \quad (4.8)$$

Naturally, in view of the oversimplified model we have used, this should only be regarded as an order-of-magnitude estimate.

A mean-field estimate of the effects of impurities presupposes that the distance between defects is equal to or smaller than a few times the value of the correlation length for the pure system, at the transition temperature of the impure system. Using numbers of Ref. 8, we estimate this correlation length as $(g/m\delta^2)^{1/2} \approx 30$ Å. The mean distance between defects implied by (5.10) is ≈ 200 Å, however, which suggests that the necessary concentration of defects may be rather higher than 10^{-5} .

Equation (4.7) predicts a slow temperature dependence for δ^2 , e.g., a decrease of 33% in the value of δ^2 as one varies T from $T_c + 10$ K to $T_c + 65$ K. This variation has not been seen experimentally. We feel that this discrepancy is probably not too significant, however, in view of the many approximations we have made.

In LaAlO₃, δ^2 is observed to be temperature independent within experimental error and has a magnitude³ ≈ 10 (K)². The other parameters are^{9,38} $T_c \approx 490$ °K, zero-temperature distortion $\approx 6^\circ$, and $d\Omega_p^2/dT \approx 8.5$ for $T > T_c$. We obtain $\delta^2 = 1.88 \times 10^5 c \alpha^2$, so that for $c \alpha^2 \approx 5 \times 10^{-5}$ we get the observed δ^2 .

In order to establish whether defects are indeed responsible for the narrow central peak in the perovskites, it is important to search for specific

defects which strongly tend to stabilize domains of the low-temperature phase, and which consequently tend to raise T_c . The authors are not aware of any impurities or defects identified to date as having the necessary properties.

V. "FROZEN" IMPURITIES

We now turn to the situations in which the impurity-cell displacements cannot relax on any experimental time scale. (This is a defect in class 2 of Appendix A, below.) A frozen defect cell may be realized within the model of Secs. II–IV if we choose the barrier Δ in the defect cell to be $\geq 50k_B T_c$, so that ν^{-1} is longer than 1 year. Alternatively, a frozen defect cell may occur if there is a frozen interstitial defect, in a site of sufficiently low symmetry.

When frozen defect cells are present, we may write the displacement field in any unit cell i , at a particular instant of time, as the sum of two terms

$$\psi_i(t) = \bar{\psi}_i + \delta\psi_i(t) , \quad (5.1)$$

where $\bar{\psi}_i$ is independent of time, while $\delta\psi_i$ has mean zero, and fluctuates about this mean value on a time scale of the order of the soft phonon frequencies. The neutron scattering structure factor $S(Q, \omega)$ is then the sum of the two contributions:

$$S(Q, \omega) = 2\pi\delta(\omega)S_e(Q) + S_p(Q, \omega) . \quad (5.2)$$

The elastic scattering structure factor $S_e(Q)$, which gives rise to a central peak of zero width, is the Fourier transform of the time-independent expectation value $\langle\langle\bar{\psi}_i\bar{\psi}_j\rangle\rangle$, whereas $S_p(Q, \omega)$ is the Fourier transform of the time-dependent correlation function $\langle\langle\delta\psi_i(t)\delta\psi_j(t')\rangle\rangle$. The inelastic scattering is related to the dynamic linear response function $\bar{\chi}_p(Q, \omega)$ in the usual way,

$$S_p(Q, \omega) = (2T/\omega) \text{Im} \bar{\chi}_p(Q, \omega) . \quad (5.3)$$

A quasielastic scattering experiment will measure a structure factor $S(Q)$ which is the sum of two terms,

$$S(Q) = S_e(Q) + S_p(Q) , \quad (5.4)$$

where

$$S_p(Q) = \int S_p(Q, \omega) \frac{d\omega}{2\pi} = T \bar{\chi}_p(Q) , \quad (5.5)$$

$$\bar{\chi}_p(Q) \equiv \lim_{\omega \rightarrow 0} \bar{\chi}_p(Q, \omega) . \quad (5.6)$$

A. Elastic scattering

We first consider a case where the impurities are sufficiently far apart so that they can be treated as isolated. Suppose that an impurity

sits at a lattice site i , with its displacement frozen in one of the two values $\psi_i = \pm C_d$. The impurity exerts a direct field on other cells in its vicinity, given by

$$h_j = \pm C_d J_{ij} . \quad (5.7)$$

In a linear approximation, this will induce a displacement in the nearby unit cells, whose Fourier transform is

$$\bar{\psi}_i(\vec{Q}) = e^{-i\vec{Q} \cdot \vec{r}_i} \frac{\pm C_d J(Q) \chi_s(Q)}{1 - \int J(Q) \chi_s(Q) [d^3Q / (2\pi)^3]} , \quad (5.8)$$

where $\chi_s(Q)$ is the static linear response of the pure system. To this must be added the contribution of the impurity cell itself,

$$\bar{\psi}_0(\vec{Q}) = \pm C_d e^{-i\vec{Q} \cdot \vec{r}_i} . \quad (5.9)$$

For Q close to Q_0 , and T close to T_c , the quantity $J(Q) \chi_s(Q)$ is large compared to 1. Nonetheless, the integral over the Brillouin zone in the denominator of (5.8) is not expected to be large, and within the spirit of mean-field theory it is proper to neglect it entirely. [Note that $\int J(Q) d^3Q$ must vanish, since $J_{ii} = 0$.] Adding up the contributions of the independent impurities, we find an elastic scattering

$$S_e(Q) = \langle |\bar{\psi}(\vec{Q})|^2 \rangle \approx c [C_d J(Q) \chi_s(Q)]^2 . \quad (5.10)$$

This expression is equivalent to the formulas for impurity scattering given in Refs. 8 and 23.

Note that Eq. (5.10) coincides with Eq. (3.29), derived for the mobile-impurity case, when $T - T_c \gg cT'$, provided we make the approximation $J(Q) \approx J_0 \approx x_n$. This is to be expected. Far from T_c , or in the dilute limit, the interaction between the impurities can be neglected. Hence the central peak is the incoherent sum of the scattering from the field about each impurity, in the relaxing case as well as in the frozen case.

B. Effect on T_c

Close to the phase transition, it becomes of great importance whether or not the defect cells can relax. In the former case, the defect cells in a given region will tend to order themselves in such a way as to favor the same orientation of the order parameter. This leads to a stabilization of the low-temperature phase, and the enhancement of T_c that we have noted previously. In the case of frozen impurities, however, this cooperative effect is absent; the impurities serve to increase fluctuations, and therefore to decrease T_c , as the effective stiffness constant $a_n + 3b\langle\psi_i^2\rangle$ is increased. We may note, in fact, that the contribution to $\langle\psi_i^2\rangle$ computed from the linear approximation (5.10)

diverges strongly as $T \rightarrow T_c$:

$$\langle \bar{\psi}_i^2 \rangle = \int S_e(Q) \frac{d^3Q}{(2\pi)^3} \propto (T - T_c)^{-1/2}. \quad (5.11)$$

Thus we expect frozen defect cells to have a rather drastic effect on the critical behavior of the system.

The static critical behavior of a system with these types of impurity has been considered recently in a renormalization-group analysis by Imry and Ma.³⁹ (In the usual terminology, this is a system with "quenched impurities" coupling linearly to the order parameter.) Imry and Ma find deviations from the critical behavior of a pure system for any spatial dimensionality d less than 6. Although they have calculated critical exponents to lowest order in $\epsilon = 6 - d$, these calculations are not very helpful for $d = 3$. Furthermore, Imry and Ma point out that in a model where the order parameter has continuous symmetry, such as the Heisenberg model, the quenched impurities will destroy long-range order at any temperature, no matter how low, for any $d < 4$. This may in fact be occurring in "nontransforming" samples of V_3Si .⁴⁰ This argument does not apply to the Ising model, or to a Heisenberg model with cubic anisotropy. Nonetheless, we may expect that frozen impurities will have a strong tendency to depress T_c below the value for the pure system. The dependence of the total scattering cross section $S(Q)$ on $T - T_c$ may also be very different from the pure system, close to T_c .

C. Effect on phonon response

In addition to the temperature dependence of the elastic scattering cross section, we would like to investigate the questions of the effect of impurities on the phonon frequencies and on the total weight of the inelastic phonon scattering.

Again it is clear that when the impurities are far enough apart, and T is well above T_c , the effect of a frozen impurity must be the same as that of a relaxing defect cell whose hopping time is very slow compared to the phonon frequencies. In the spirit of the mean-field theory of the previous sections, we would estimate the effects of the frozen impurities by simply assuming that $\delta\psi_i$ is constrained to be zero on the impurity sites, and assume that the dynamic effective field on any other site is therefore reduced by the factor $1 - c$. This will shift the phonon frequencies upwards, and decrease the response function $\bar{\chi}_p$ by a small amount, proportional to the concentration c , which is the same as we have computed in Sec. III.⁴¹ Examination of the calculations of Sec. III will show, however, that this stiffening is a relatively

small effect compared with the raising of T_c by the defects in the relaxing case. In fact, we found that the temperature $T_c - cT'$, at which $[\chi_p(Q_0)]^{-1}$ extrapolates to zero, is only slightly below the transition temperature T_c^0 of the pure system, while T_c^0 was much further below the actual transition temperature (i.e., $T' \approx dT_c/dc$). In the frozen case, however, the actual transition temperature of the impure system will be *below* T_c^0 . Therefore, if temperature is measured relative to the actual transition temperature in each case, we expect that $\bar{\chi}_p^{-1}$ for the frozen defect cells will be below the values in the relaxing case. (Compare Figs. 1 and 3.) If the two cases are plotted on the same absolute temperature scales, so that the curves match far from T_c , then $\bar{\chi}_p^{-1}$ will be higher for the frozen case in the vicinity of T_c . At the present time it is not entirely clear whether $\bar{\chi}_p^{-1}$ will remain finite at T_c , for the frozen case, as in a first-order transition, or whether $\bar{\chi}_p^{-1}$ will approach zero as some power of T_c . It is also unclear how the ratio $S_p(Q)/S_e(Q)$ will behave.

It is interesting to speculate on the frequency dependence of $S_p(Q, \omega)$ for the frozen-impurity case. For temperatures some distance below T_c^0 , but still above the actual transition temperature, it seems reasonable to picture the material as a series of domains, with the orientation of the order parameter in any region determined by the orientation of the nearest impurity, or perhaps by a small cluster of impurities. (Recall that we are discussing a situation in which there is a small density of impurities, each of which is strongly coupled to the local order parameter.) It seems plausible that below T_c^0 , the domain walls

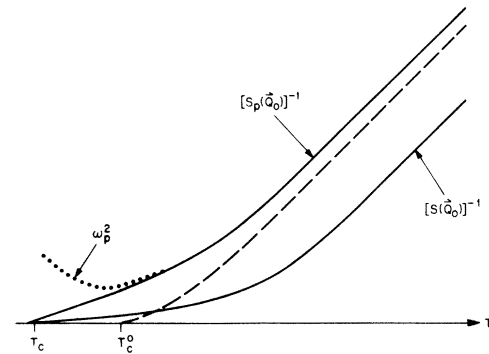

FIG. 3. Schematic plot of the inverse of the total form factor $S(Q_0)$, and of the inelastic contribution $S_p(Q_0)$, for a system with "frozen defect cells" of type 2. The dashed curve indicates $[S(Q_0)]^{-1}$ for the pure system. Dashed curve indicates possible temperature dependence of the squared phonon frequency ω_p^2 . Curves in the region $T < T_c^0$ should be regarded as highly speculative.

may become sharp on the scale of the domain size, and that within a domain, the magnitude of the order parameter may be roughly equal to its value in the pure system. If this is the case, we would expect to see a phonon spectrum characteristic of the pure material, which means that the phonon frequencies will *rise* and the corresponding neutron scattering intensity *decrease*, as the temperature is lowered further. There would be an additional inelastic scattering, however, from motion of the boundaries between domains. This might well be an activated process whose frequency would decrease as T decreases. The structure factor $S(k, \omega)$ would then consist of three parts: an elastic scattering peak, of zero width, whose amplitude diverges as T_c is approached from above (assuming a second order transition); a pair of phonon peaks whose frequency at first decreases with decreasing temperature, but then begins to increase before T_c is reached; and a second central peak that separates from the phonon peaks and continues to grow narrower as T_c is approached. It is also possible that in some cases the phonon peaks will be overdamped, which would complicate the identification of this situation.

The authors are not aware of any experimental results which suggest that frozen defect cells, rather than relaxing defect cells, are responsible for a central peak in any material. Nonetheless, this possibility should be borne in mind, and further theoretical and experimental investigation of this possibility would be worthwhile.

VI. BEYOND THE MEAN-FIELD APPROXIMATION

In order to obtain the results of Sec. III, we were forced to make a number of drastic simplifying assumptions. Our simple mean-field theory is incorrect on two counts. First, we have not correctly treated the nonlinear interactions between thermal fluctuations, so that we do not obtain the proper critical behavior even for the pure substance. Second, we have not correctly treated the multiple scattering of phonons by the impurities, and we would not obtain a precisely correct phonon spectrum even for a model in which anharmonic forces could be neglected. In the present section we will discuss the degree to which we may have confidence in the qualitative features predicted by the mean-field solution.

A. Dynamics of the pure system

Our first concern is the extent to which the mean-field solution for the pure system is qualitatively correct. We shall argue that the mean-field solution is quite similar to what one would expect for this system based on renormalization-group

considerations and the universality hypotheses for dynamic critical phenomena, and therefore it seems very unlikely to us that an exact solution of the model without defects could reproduce the qualitative features of the central peak in SrTiO₃.

Universality hypotheses state that the asymptotic critical behavior of a system is independent of most details of the Hamiltonian, and is determined by certain overall properties, such as spatial dimensionality and order-parameter symmetry,⁴² and (for dynamic properties) conservation laws and Poisson-bracket relations among the order-parameter and conserved quantities.⁴³ Although the universality hypotheses are by no means rigorously proved, they tend to be supported by numerous pieces of evidence, including the stability of the renormalization-group results to small perturbations, results of high-temperature series expansions for models on various kinds of lattices, and experimentally observed similarities in the critical behavior of systems which are supposed to fall in a given "universality class."

Renormalization-group calculations, which have now been carried out for a large variety of dynamic systems, have been based for the most part on an expansion in the variable $\epsilon = 4 - d$, where d is the spatial dimensionality. In addition, the calculations are carried out for continuum models, with weak quartic interactions. The predictions of these calculations are reinforced, however, by their good agreement with Monte Carlo calculations and high-temperature series expansions for the two-dimensional kinetic Ising model.^{44,45} We may note that an Ising model is the extreme anharmonic limit of the phonon model of Sec. II, and is, in a sense, further from the models studied by the renormalization group than the displacive system. It also seems unlikely that the renormalization-group calculations should work at $d = 2$ and near $d = 4 - \epsilon$, and yet be radically wrong at $d = 3$.

According to the universality hypotheses for dynamic critical phenomena,⁴³ we expect the asymptotic critical behavior of the pure system to be the same as that of a purely relaxational continuum model (time-dependent Ginzburg-Landau model) with energy conservation, such as has been studied by Halperin, Hohenberg, and Ma.⁴⁶ They find a relaxation rate for critical fluctuations which we may write in the form

$$i\omega_p(Q, T) \approx \eta_0 [\bar{\chi}_S(Q)]^{-x}, \quad (6.1)$$

where $\bar{\chi}_S$ is the static linear response function, η_0 is a constant, and the exponent x is slightly greater than 1. The line shape for critical scattering is Lorentzian for $d = 4$, but we expect to find deviations from Lorentzian behavior at $d = 3$,

with increased weight in the wings of the line.

The mean-field-theory predictions for the pure system may be obtained by setting the impurity concentration c equal to zero in the results of Sec. III. We see that the phonon peaks become overdamped for T sufficiently close to T_c and Q close to Q_0 . There is then a single central peak whose width is given by

$$i\omega_p = m\Omega_p^2/\gamma = \gamma^{-1}[\bar{\chi}_S(Q)]^{-1}. \quad (6.2)$$

This can be fit neatly onto the asymptotic critical behavior (6.1) if

$$\eta_0 \approx \gamma^{-1}. \quad (6.3)$$

[More accurately, we should have $\eta_0 \approx \gamma^{-1}\bar{\chi}_0^{-1}$, where $\bar{\chi}_0$ is the value of the $\bar{\chi}_S(Q_0)$ at a temperature where deviations from mean-field exponents first become important.] This behavior is also in agreement with renormalization-group calculations of a damped phonon model by Murata.⁴⁷

For an *Ising-like* transition ($n=1$), where the specific heat diverges, an alternate estimate of the constant η_0 is suggested by the renormalization-group analysis of Ref. 46. In the *asymptotic critical region*, the relaxation rate $i\omega_p(Q_0)$ is approximately given by^{46,48}

$$i\omega_p(Q_0) \approx 0.7D_T\kappa^2, \quad (6.4)$$

where D_T is the thermal diffusion constant at the temperature in question, and κ is the reciprocal of the correlation length. Using the notation of Sec. III, we may estimate the thermal diffusion constant outside the critical region. Since a typical phonon velocity is given by $v = (g/m)^{1/2}$, and a typical phonon relaxation rate $\tau^{-1} = \gamma/m$, we estimate⁴⁹

$$D_T \approx \frac{1}{3}v^2\tau = \frac{1}{3}g/\gamma. \quad (6.5)$$

In the mean-field region, we also have

$$\kappa^2 = g^{-1}[\bar{\chi}_S(Q_0)]^{-1}, \quad (6.6)$$

so that comparing (6.4)–(6.6) with (6.1), we would again estimate that η_0 should have the order of magnitude of γ^{-1} .

We emphasize that the relaxation rate for the pure system predicted by (6.1) with $\eta_0 = \gamma^{-1}$, is not small compared to the soft phonon frequency except very close to T_c . For example, the predicted width would be of order 1 meV for SrTiO_3 at $T - T_c \approx 10$ K. This relaxation rate clearly has nothing to do with the observed central peaks, which are much narrower.

It is interesting to note that molecular-dynamics calculations²⁴ for a (pure) two-dimensional model of a system near a displacive transition are in substantial agreement with this picture. Although the phonon spectrum was found to have a number

of interesting features worthy of further study, the dominant scattering for $Q=Q_0$, and T slightly above T_c , may be described as a single overdamped mode. Since the published results²⁴ do not give the temperature dependence of the central-peak width in the displacive case, we could not make a detailed comparison with (6.1) and (6.3). The magnitude of the relaxation rate seems to be in qualitative agreement with this estimate however.

We also feel that the results of Aubry, of Krumhansl and Schrieffer,²⁶ and of Varma²⁷ for a one-dimensional system lend support to our picture of relaxation in a pure system. The width of the central peak at low temperatures in their model may be written in the form

$$\Gamma_{Q_0} \propto \bar{v}\kappa, \quad (6.7)$$

where \bar{v} is a typical velocity of motion of a domain wall. The fact that Γ_{Q_0} becomes extremely small at low temperatures is simply due to the fact that the correlation length κ^{-1} grows exponentially with $1/T$, in one dimension. (The velocity \bar{v} is a much slower function of temperature.) The occurrence of the velocity \bar{v} in (6.7) is a consequence of the peculiarity of these one-dimensional models, in which one of the solutions of the resulting nonlinear equations of motion has a stationary solution in the frame traveling with velocity \bar{v} . In two and three dimensions such solutions are not obtained (except possibly for very special kinds of nonlinearities). In three dimensions we might expect a diffusive motion of “domain walls,” just above T_c . This would lead to relaxation rate of the form $D\kappa^2$ for $T > T_c$, where D is a diffusion rate for a domain boundary, and we choose the domain size to be of the order of the correlation length κ^{-1} . In the pure system, where there are no defects to pin the domains, we might expect that the thermal diffusion constant D_T appearing in (6.4) is not a bad estimate for D . On the other hand, we may note that even if (6.6) is used, then Γ_{Q_0} will not be particularly small compared to the soft phonon frequency, if \bar{v} is comparable to the sound velocity. Molecular-dynamics calculations on one-dimensional systems²⁵ are in general agreement with the analyses of Refs. 26 and 27.

A number of authors¹⁷⁻²³ have performed approximate microscopic calculations of one kind or another for three-dimensional (defect-free) models, in the hope of explaining the observed central peaks at structural transitions. We shall not discuss the merits of these various calculations here, but shall simply reiterate that to the best of our knowledge, none of these calculations have yielded a central peak that is sufficiently narrow to explain the observations in SrTiO_3 .

B. System with defects

It seems clear that certain qualitative features of the mean-field solution for our model with relaxing defect cells are independent of our approximation—e.g., the simultaneous existence of a narrow central peak in $S(Q, \omega)$ whose frequency scale is set by the hopping rate ν , and a “high-frequency” part, whose frequency scale is set by the phonon frequencies. Some important quantitative features which will not be correct, however, are the precise behavior of the total weight $\bar{\chi}_S(Q)$ for $T \rightarrow T_c$ and $Q \rightarrow Q_0$; the precise behavior of the central-peak width as $T \rightarrow T_c$; the exact shape and overall width of the phonon part; the precise amount of weight left in the phonon part [i.e., the quasistatic susceptibility $\bar{\chi}_p(Q)$].

These questions might be answered in part by a more realistic treatment of the phonon system. (For example, a self-consistent phonon approximation,⁵⁰ taking proper account of the root-mean-square fluctuations from all the phonon modes throughout the Brillouin zone, might give considerable improvement over the approximations of Sec. III, for the transition in the pure system.) Similarly, the scattering of the phonons by the defects might be better treated by a more sophisticated approximation, such as the coherent-potential approximation.³⁷ Alternatively, we may also gain some insight into these problems by comparing with renormalization-group calculations, which should describe the asymptotic behavior sufficiently close to T_c .

We shall review here some of the relevant results of renormalization-group calculations, for a system with defects of type 1 or 3 according to the classifications of Appendix A. The case of a system with “frozen defect cells” (type 2) was discussed in Sec. V, and will not be included here.

C. Static properties

The first of the questions posed above, the behavior of $\bar{\chi}_S(Q)$, has been studied rather extensively in the recent past, using renormalization-group techniques. Here it is necessary to distinguish the “completely mobile” cases (types 1a and 3b) from the “trapped” cases (1b and 3b). (See Table I. According to the terminology current in the renormalization-group papers the trapped cases would be classified as “quenched impurities, with a quadratic coupling to the order parameter.”^{51,52}) It should make no difference for the ultimate critical behavior of $\bar{\chi}_S$ whether the defect unit cells are weakly perturbed (3a, 3b) or strongly perturbed, as in the relaxing cases (1a, 1b).

The completely mobile case is relatively simple. The impurities cause a shift in T_c , but no change in the asymptotic critical behavior of $\bar{\chi}_S(Q)$ relative to that of the pure system, provided that $T - T_c$ is corrected to refer to measurements at constant chemical potential rather than constant impurity concentration. Thus, for a system with a scalar order parameter, we expect Ising-like behavior⁴² [e.g., $\bar{\chi}_S(Q_0) \propto (T - T_c)^{-1.25}$]. In SrTiO_3 , the order parameter has six possible orientations, which would be classified as a Heisenberg-like system ($n=3$) with strong cubic anisotropy [i.e., terms of the form $\sum_{\alpha=1}^3 \psi_\alpha^4$ and $\sum_{\alpha=1}^3 (q_\alpha \psi_\alpha)^2$]. Ultimately this should lead to Heisenberg behavior [e.g., $\bar{\chi}_S(Q_0) \propto (T - T_c)^{-1.38}$]; however, the cubic anisotropy is only weakly “irrelevant,” and deviations from Heisenberg behavior would not be surprising in any accessible temperature range.⁴²

The presence of “quenched” impurities (cases 1b or 3b) is expected to modify the asymptotic critical behavior, in the case of a scalar order parameter. The renormalization-group leads to a fixed point whose exponents differ from the ordi-

TABLE I. Classes of defect cells.

Class	Description
1	“Relaxing defect cells”—asymmetry is strongly favored but equilibrium is maintained via slow hopping between the various orientations
1a	“Mobile”—defect may hop from cell to cell
1b	“Locally relaxing”—defect trapped in given unit cell
2	“Frozen” defect cell—asymmetry is frozen in
3	Weakly perturbed defect cell—symmetry is maintained via rapid vibration between possible orientations
3a	“Mobile”—defect hops from cell to cell
3b	“Quenched defect”—defect trapped in a given unit cell

nary Ising values.^{51,52} However, the “crossover exponent” is given by the specific-heat exponent α , which is small ($\alpha \approx \frac{1}{8}$). Thus the system would probably always be fairly close to the pure-Ising fixed point, over any accessible temperature range, if the impurity concentration is small.

In the Heisenberg or cubic case, the asymptotic behavior depends on the symmetry of the site, or group of sites, at which a given impurity is trapped. If the impurity site has the full cubic symmetry, the crossover exponent is again α , which is now negative, so that the impurities are irrelevant. If the impurity introduces a local “uniaxial” anisotropy, e.g., a perturbation of the form $\psi_1^2 + \psi_2^2 - 2\psi_3^2$, the crossover exponent is positive, and the asymptotic critical behavior is changed by the presence of the defects. It has been suggested⁵² that some form of “smeared” transition will result in this case.

It may be noted that lines of defects, or other strong spatial correlations among defects, may also enhance the importance of defects, and will also lead to smearing of the transition.

D. Dynamic properties

Grinstein, Ma, and Mazenko⁵³ have given a renormalization-group treatment of the critical dynamics of a model with quenched impurities, which couple quadratically to the order parameter and do not break the symmetry of the high-temperature phase. They have developed recursion relations analogous to those employed in Ref. 46 to obtain results correct to lowest order in $4-d$ for systems without impurities. They find a relaxation rate for the order parameter of the same form as (6.1), with an exponent x which is again close to 1. The precise value of x may differ somewhat from that in the pure case, as was observed for the static critical exponents.

Invoking the universality hypothesis, we would like to apply these results to our cases 1*b* and 3*b*, where trapped defects are present. For the case of weakly perturbed defect cells, 3*b*, we would estimate $\eta_0 \approx \gamma^{-1}$, as in the pure case. For the strongly coupled case of trapped relaxing defect cells, 1*b*, we could apply the results of Grinstein *et al.* to the width of the central peak. By matching onto the mean-field results of Sec. III, we estimate

$$\Gamma_Q = \eta_0 [\bar{\chi}_S(Q, T)]^{-x}, \quad (6.8)$$

$$x \approx 1, \quad (6.9)$$

$$\eta_0 \approx \nu \bar{\chi}_S(Q_0, T_c + cT'). \quad (6.10)$$

Unfortunately, these results do not provide answers to some of the most interesting questions

in the strongly coupled case (1*b*)—the questions of the weight and shape of the (nondiverging) phonon contribution to $S(Q, \omega)$. At this point we can only offer a guess as to the best way to extend the results of Sec. III. The simplest estimate for the phonon contribution to the susceptibility is

$$\bar{\chi}_p(Q, T) \approx \bar{\chi}_S(Q, T + cT'), \quad (6.11)$$

where cT' must be fit experimentally, if neither c nor T' is known precisely. Further, we propose that the characteristic phonon frequency may be approximated by the form (3.24) with

$$m\Omega_p^2 \approx \bar{\chi}_p^{-1}. \quad (6.12)$$

The critical dynamics of a system with mobile defects (1*a* and 3*a*) may also be discussed using the renormalization group. From the point of view of the universality class expected for the ultimate critical behavior, in the limit $T - T_c$, these cases should be described by the model used for the *pure* system, model C of Ref. 46. The relevant conserved field is now the local concentration of impurities, rather than the energy density. Insofar as the diffusion rate for impurities is very slow compared to the relaxation rate for the order parameter, we are forced to consider the case where the parameter μ_0 of Ref. 46 is equal to zero. In this limit one encounters difficulties in applying the renormalization group—the usual recursion relations are probably not correct to lowest order in $4-d$. (These problems are discussed more fully in Ref. 48.) The overall behavior of the system seems to be quite similar qualitatively to the quenched-impurity case, and we would propose that the same approximations be used to estimate the results; i.e., we would use Eqs. (6.7)–(6.11) to describe the case 1*a*, of mobile relaxing defect cells, while the weakly perturbed case 3*a* would be described by (6.1) and (6.3).

When the spatial correlations or symmetry-breaking properties of trapped defects are such as to lead to a “smeared transition,” as discussed above, there will be some temperature region above the “average” T_c in which relatively large regions of the system are frozen into the low-temperature phase. We would expect to see a very narrow central peak in this temperature range even if the impurities tend to lower the average T_c .

Note added in proof: Recent EPR results on Cr^{5+} substituted for As in KD_2AsO_4 , indicate that the ion undergoes a spontaneous displacement, together with a tilt in orientation of the paramagnetic d -orbital, in a direction which couples linearly to the order parameter of the ferroelectric transition ($T_c \approx 140$ K). The hopping time between

different configurations is found to be slower than 10^{-8} sec for temperatures up to 300 K. [K. A. Müller and W. Berlinger (unpublished), and private communication].

ACKNOWLEDGMENTS

The authors are grateful for helpful discussions with J. D. Axe, P. A. Fleury, P. Heller, P. C. Hohenberg, and K. A. Müller.

APPENDIX: CLASSIFICATION OF DEFECTS

The manner in which an impurity or defect is coupled to the order parameter of a phase transition will depend on the site it occupies. At first sight, we may divide the impurity sites into two types:

A: If the impurity sits at a site which properly breaks the symmetry of the high-temperature phase, it will couple linearly to the order parameter. There will then be an induced nonzero value of the order parameter in the neighborhood of the impurity, even above T_c , which will give rise to an elastic scattering peak whose magnitude increases as $T \rightarrow T_c$, for wave vectors near the superlattice vector of the ordered phase.

B: If the impurity sits in a site which has a high symmetry, then there will be no linear coupling to the order parameter, and the order parameter will not normally have a static expectation value above T_c in the vicinity of the impurity.

It may be noted that in SrTiO_3 any substitutional impurity or vacancy will fall into class *B* (see Fig. 2). An interstitial impurity will also not couple linearly to the order parameter if it sits in a high-symmetry site, such as *U* in Fig. 2. However, if the impurity sits at the interstitial sites *V* or *V'*, then there will be a linear coupling to the order parameter as indicated.⁵⁴

The distinction between the two types of impurity sites may not be as clear cut as it seems, however. For example, an impurity at a symmetry site (type *B*) may so change the spring constants in its cell that the high-temperature phase is unstable, and the low-temperature phase is strongly favored. In that case there will be a spontaneous displacement of the atoms in the vicinity of the impurity into one or another of the possible configurations of the low-temperature phase, which may be quite stable even above T_c —i.e., the configurations may be separated from the other possible positions by an energy barrier Δ large compared to kT . Furthermore, any impurity (type *A*) which likes to sit at the symmetry-breaking site *V* of Fig. 2 can equally well sit at the physically equivalent site *V'*. If the barrier Δ for hopping from site *V* to site *V'* is not too large

($\Delta \lesssim 40k_B T$), then the impurity will spend an equal amount of time on each of the possible sites, and the time-averaged value of the order parameter will be zero. (Note that barrier Δ may be considerably smaller than the barrier preventing an impurity from diffusing from one unit cell to the next.)

It is clear that once one takes into account the possibility of impurity hopping, or spontaneous symmetry breaking within the defect cell,⁵⁵ the distinction between type-*A* impurities and type-*B* impurities is not in itself important. More important are the time-dependent properties of the defect cell as a whole. A more complete description would be as follows:

A1: The impurity goes into a symmetry-breaking site but can hop to a site of the opposite symmetry within a time short compared to the duration of the experiment.

B1: The impurity goes *a priori* into a symmetric position but changes the local spring constants so that spontaneous symmetry breaking takes place locally, with an energy barrier Δ that is large compared to T_c , but small enough so that hopping between various configurations can take place during the course of the experiment. Note that in this case it is not necessary for the impurity itself to hop.

We shall group type *A1* and *B1* impurities together into the class of “relaxing defect cells” (class 1).

Continuing with our description of impurity cells, we list:

A2: The impurity is “frozen” in a symmetry-breaking position and cannot move to another site during the course of an experiment, for temperatures of the order of T_c .

B2: Although the impurity occupies a symmetric site, it favors the low-temperature phase so strongly that the local spontaneous symmetry breaking is frozen for temperatures of the order of T_c , and cannot readjust during the course of the experiment.

We shall group together type-*A2* and -*B2* impurities into the class of “frozen defect cells” (class 2).

Finally we may consider defects such as follows:

B3: The impurity occupies a symmetric site and either favors the high-temperature phase, or favors the low-temperature phase only weakly. The local symmetry, above T_c , is broken only by fluctuations with the frequency scale of the phonons, as in the pure system, and there will be no quasistatic expectation value of the order parameter in the vicinity of the impurity.

We shall classify this kind of defect cell as “weakly perturbed” (class 3).

We may further subdivide the relaxing and weakly perturbed defect cells (classes 1 and 3) into a "mobile" situation (denoted 1a and 3a), in which the impurity is able to diffuse freely from one unit cell to another during the course of an experiment, and a "trapped" situation (denoted 1b and 3b), in which diffusion from cell to cell may be neglected. The distinction between mobile and trapped is unimportant in our mean-field-theory approximation; however, the two situations are expected to lead to differences in the precise form of the correlation functions very close to T_c ,

where renormalization-group techniques must be used.

A summary of our classification scheme is given in Table I. We have seen in the text that a narrow central peak is produced in both the relaxing case (class 1) and the frozen case (class 2). The behavior near the transition is rather different in the two cases, however, and we have therefore discussed these situations separately. A narrow central peak would not be obtained for the weakly perturbed case (class 3), at least within the mean-field approximation.

*Present address: Physics Dept., Harvard Univ., Cambridge, Mass. 02138.

¹W. Cochran, *Adv. Phys.* **9**, 387 (1960).

²P. W. Anderson, in *Fizika Dielektrikov*, edited by G. I. Skanava and K. V. Filippov (Academy of Sciences, USSR, Moscow, 1960), p. 290.

³H. Juretschke, R. Landauer and P. Sorokin (unpublished), cited by Cochran in Ref. 1.

⁴B. D. Silverman and R. I. Joseph, *Phys. Rev.* **129**, 2062 (1963).

⁵R. A. Cowley, *Philos. Mag.* **11**, 673 (1965).

⁶T. Riste, E. J. Samuelson, and K. Otnes, in *Structural Phase Transitions and Soft Modes*, edited by E. J. Samuelson, E. Andersen, and J. Feder (Universitetsforlaget, Oslo, 1971); T. Riste, E. J. Samuelson, K. Otnes, and J. Feder, *Solid State Commun.* **9**, 1455 (1975).

⁷S. M. Shapiro, J. D. Axe, G. Shirane, and T. Riste, *Phys. Rev. B* **6**, 4332 (1972).

⁸J. D. Axe, S. M. Shapiro, G. Shirane, and T. Riste, in *Anharmonic Lattices, Structural Transitions and Melting*, edited by T. Riste (Noordhoff-Leiden, Groningen, 1974), p. 23.

⁹J. K. Kjems, G. Shirane, K. A. Müller, and H. J. Scheel, *Phys. Rev. B* **8**, 1119 (1973).

¹⁰K. Gesi, J. D. Axe, and G. Shirane, *Phys. Rev. B* **5**, 1933 (1972).

¹¹N. Lagakos and H. Z. Cummins, *Phys. Rev. B* **10**, 1063 (1974).

¹²J. D. Axe and G. Shirane, *Phys. Rev. B* **8**, 1965 (1973).

¹³K. A. Müller, in *Structural Phase Transitions and Soft Modes*, edited by E. J. Samuelson, E. Andersen, and J. Feder (Universitetsforlaget, Oslo, 1971), p. 85; K. A. Müller, W. Berlinger, C. H. West, and P. Heller, *Phys. Rev. Lett.* **32**, 160 (1974); K. A. Müller, in *Anharmonic Lattices, Structural Transitions and Melting*, edited by T. Riste (Noordhoff-Leiden, Groningen, 1974), p. 39.

¹⁴J. Töpler, B. Alefeld, and A. Kollmar, *Phys. Lett.* **51A**, 297 (1975).

¹⁵F. Mezei and J. B. Hayter, reported at the EPS Conference Budapest, 1974 (unpublished) cited in Ref. 8.

¹⁶C. N. W. Darlington, W. J. Fitzgerald, and D. A. O'Connor, *Phys. Lett.* **54A**, 35 (1975).

¹⁷R. A. Cowley, *J. Phys. Soc. Jpn. Suppl.* **28**, 239 (1970); G. J. Coombs and R. A. Cowley, *J. Phys. C* **6**, 121 (1973).

¹⁸J. Feder, *Solid State Commun.* **9**, 2021 (1971); R. Sil-

bergliitt, *ibid.* **11**, 247 (1972).

¹⁹F. Schwabl, *Solid State Commun.* **13**, 181 (1973). This paper predicts a central peak whose width is approximately three times the width of a typical phonon peak.

²⁰C. P. Enz, *Phys. Rev. B* **12**, 4695 (1972).

²¹C. P. Enz, *Helv. Phys. Acta.* **47**, 749 (1974).

²²K. K. Murata, *Phys. Rev. B* **11**, 462 (1975).

²³F. Schwabl has given a critical review of some of the previous microscopic theories, in *Anharmonic Lattices, Structural Transitions and Melting*, edited by T. Riste (Noordhoff-Leiden, Groningen, 1974), p. 87; R. Folk and F. Schwabl, *Solid State Commun.* **15**, 937 (1974).

²⁴T. Schneider and E. Stoll, *Phys. Rev. Lett.* **31**, 1254 (1973); *Phys. Rev. B* **13**, 1216 (1976).

²⁵Y. Ishibashi and Y. Takagi, *J. Phys. Soc. Jpn.* **33**, 1 (1972); S. Aubry and R. Pick, *Ferroelectrics* **8**, 471 (1974); T. Schneider and E. Stoll, *Phys. Rev. Lett.* **35**, 296 (1975); T. R. Koehler, A. R. Bishop, J. A. Krumhansl, and J. R. Schrieffer, *Solid State Commun.* **17**, 1515 (1975).

²⁶S. Aubry, *J. Chem. Phys.* **62**, 3217 (1975); J. Krumhansl and J. R. Schrieffer, *Phys. Rev. B* **11**, 3535 (1975).

²⁷C. M. Varma, *Phys. Rev. B* **14**, 244 (1976).

²⁸We wish to distinguish calculations based on a well-defined microscopic model from a phenomenological theory, such as that described in Ref. 29, in which a narrow central peak was obtained through the introduction of a long-time constant of unknown physical origin.

²⁹F. Schwabl, *Z. Phys.* **254**, 57 (1972); *Phys. Rev. Lett.* **28**, 500 (1972).

³⁰See, for example, H. Thomas, in *Structural Phase Transitions and Soft Modes*, edited by E. J. Samuelson, E. Andersen, and J. Feder (Universitetsforlaget, Oslo, 1971).

³¹T. Kodama, *J. Magn. Reson.* **7**, 137 (1972); C. W. Garland and R. J. Pollina, *J. Chem. Phys.* **58**, 5002 (1973).

³²Y. Yamada, H. Takatera, and D. L. Huber, *J. Phys. Soc. Jpn.* **36**, 641 (1974).

³³P. G. DeGennes, *Solid State Commun.* **1**, 132 (1968); R. Brout, K. A. Müller, and H. Thomas, *Solid State Commun.* **4**, 507 (1966).

³⁴K. K. Kobayashi, *J. Phys. Soc. Jpn.* **24**, 497 (1968); R. J. Elliott and A. P. Young, *Ferroelectrics* **7**, 23 (1974).

³⁵H. Z. Cummins, in *Proceedings of the Puerto Rico*

- Conference on Superconductivity and Soft Modes, San Juan, Puerto Rico, 1976 (unpublished).
- ³⁶L. R. Walker (unpublished); results are quoted in R. J. Birgeneau, L. R. Walker, H. Guggenheim, J. Als-Nielsen, and G. Shirane, *J. Phys. C* **8**, L328 (1975).
- ³⁷See, for example, R. J. Elliott, J. A. Krumhansl, and P. L. Leath, *Rev. Mod. Phys.* **46**, 465 (1974).
- ³⁸K. A. Müller, W. Berlinger, and F. Waldner, *Phys. Rev. Lett.* **21**, 814 (1968).
- ³⁹Y. Imry and S. Ma, *Phys. Rev. Lett.* **35**, 1399 (1975).
- ⁴⁰J. Noolandi and C. M. Varma, *Phys. Rev. B* **11**, 4742 (1975).
- ⁴¹A more accurate calculation, in either the frozen or mobile case might take into account as well the increased stiffness of the cells in the neighborhood of the impurity. The frequency of a phonon would then be shifted by an amount proportional to a calculated forward scattering amplitude from the inhomogeneous region about the impurity.
- ⁴²For a review, see M. E. Fisher, *Rev. Mod. Phys.* **46**, 597 (1974).
- ⁴³Calculations of dynamic critical phenomena have been reviewed by B. I. Halperin, in *Proceedings of the International Conference on Statistical Physics, Budapest, 1976*, edited by P. Szepfalusy (to be published).
- ⁴⁴H. Yahata and M. Suzuki, *J. Phys. Soc. Jpn.* **27**, 1421 (1969).
- ⁴⁵E. Stoll, K. Binder, and T. Schneider, *Phys. Rev. B* **8**, 3266 (1973).
- ⁴⁶B. I. Halperin, P. C. Hohenberg, and S. Ma, *Phys. Rev. B* **10**, 139 (1974).
- ⁴⁷K. K. Murata, *Phys. Rev. B* **13**, 2028 (1976).
- ⁴⁸B. I. Halperin, P. C. Hohenberg, and S. Ma, *Phys. Rev. B* **13**, 4119 (1976).
- ⁴⁹This estimate of the thermal diffusivity seems to work reasonably well for SrTiO₃. From the neutron data of Ref. 8, we have $g/m \approx 500-100 \text{ meV}^2 \text{ \AA}^2$, and $\gamma/m = 0.88 \text{ meV}$, so that the right-hand side of (6.5) is of order 300 meV \AA^2 . The experimental value of D_T quoted in Ref. 21 is 812 meV \AA^2 .
- ⁵⁰See, for example, T. R. Koehler, in *Lattice Dynamics*, edited by A. A. Maradudin and G. K. Horton (North-Holland, Amsterdam, 1974); H. Horner, *ibid.*; C. M. Varma and N. R. Werthamer, in *Liquid and Solid Helium*, edited by K. Benneman and J. Ketterson (Wiley, New York, 1976).
- ⁵¹A. B. Harris and T. C. Lubensky, *Phys. Rev. B* **11**, 3573 (1975); D. E. Khmel'nitsky, *Zh. Eksp. Teor. Fiz.* **68**, 1960 (1975); [*Sov. Phys. - JETP* **41**, 981 (1976)]; G. Grinstein and A. Luther, *Phys. Rev. B* **13**, 1329 (1976).
- ⁵²A. Aharony, *Phys. Rev. B* **12**, 1038 (1975).
- ⁵³G. Grinstein, S. Ma, and G. F. Mazenko (private communication).
- ⁵⁴An impurity on an oxygen site in SrTiO₃, or at a position such as U in Fig. 2, will reduce the symmetry of the high-temperature phase by introducing a local "uniaxial anisotropy." The symmetry is still too high to permit a linear coupling to the order parameter, however, and such an impurity may be considered an nonsymmetry breaking (type B) from the point of view of our mean-field theory. Very close to T_c , where renormalization-group analyses become necessary, the presence of random uniaxial anisotropy will become important.
- ⁵⁵A number of impurities substitutional for Sr or Ti are known to displace spontaneously along one of the cubic axes in the high-temperature phase of SrTiO₃ [see, for example, O. F. Schirmer and K. A. Müller, *Phys. Rev. B* **7**, 2986 (1973)]. Such a displacement, by itself would leave the impurity in a site with symmetry still too high to couple linearly to the order parameter. However, for a Ti³⁺ impurity on the strontium site, the EPR data show that there is a further displacement towards one of the neighboring oxygen ions, which does couple linearly to the order parameter (K. A. Müller, private communication).