

Supremacy of incoherent sudden cycles

Jukka P. Pekola,¹ Bayan Karimi,¹ George Thomas,¹ and Dmitri V. Averin²

¹*QTF centre of excellence, Department of Applied Physics, Aalto University School of Science, P.O. Box 13500, 00076 Aalto, Finland*

²*Department of Physics and Astronomy, Stony Brook University, SUNY, Stony Brook, New York 11794-3800, USA*



(Received 28 December 2018; revised manuscript received 12 May 2019; published 6 August 2019)

We investigate theoretically a refrigerator based on a two-level system (TLS) coupled alternately to two different heat baths. Modulation of the coupling is achieved by tuning the level spacing of the TLS. We find that the TLS, which avoids quantum coherences, creates finite cooling power for one of the baths in sudden cycles, i.e., acts as a refrigerator even in the limit of infinite operation frequency. By contrast, the cycles that create quantum coherence in the sudden expansions and compressions lead to heating of both the baths. We propose a driving method that avoids creating coherence and thus restores the cooling in this system. We also discuss a physical realization of the cycle based on a superconducting qubit coupled to dissipative LC resonators.

DOI: [10.1103/PhysRevB.100.085405](https://doi.org/10.1103/PhysRevB.100.085405)

I. INTRODUCTION

In quantum thermodynamics, one of the timely questions is whether and under what conditions quantum features such as entanglement and coherence can enhance the performance of heat engines and refrigerators [1–3]. In many models of such machines, quantum coherence is found to be useful [4–11], whereas its adverse effect has also been reported [12–16] or its usefulness may even depend on the quantity of interest [17]. An interesting regime is given by sudden cycles where control parameters of the system change infinitely rapidly. In this limit, the system poses potentially a powerful engine or refrigerator [18,19]. It has been suggested that refrigeration is made possible by quantum coherence in such cycles [2,20,21]. Here we show in a simple yet realistic scheme that, on the contrary, an “incoherent” refrigerator which avoids creating off-diagonal elements of the density matrix in the eigenbasis of the instantaneous Hamiltonian, produces a finite cooling power in the sudden limit, while creation of coherence is a disadvantage and completely forbids cooling. Furthermore, we demonstrate that it is possible to suppress coherence and thereby restore cooling in a quantum system in sudden cycles. For practical implementation, we present an experimentally feasible circuit using a superconducting qubit, where the presented cycle can be naturally realized. Our main results on the points above are captured by the final expressions in Eqs. (9), (13), and (14).

II. DESCRIPTION OF THE SYSTEM AND CYCLE

We first present an abstract model of our cooling cycle and then introduce a physical implementation of it based on a superconducting qubit. The idea is shown in Fig. 1(a). A two-level system (TLS) is sandwiched between the two baths at temperatures $T_C \equiv 1/(k_B\beta_C)$ and $T_H \equiv 1/(k_B\beta_H)$. The essence of the cooling cycle is that when the level spacing is tuned to its low value ΔE_C , the system is coupled to the cold bath only, with the relaxation rate of Γ_\downarrow^C , and similarly, when the spacing assumes the higher value ΔE_H , the system

couples only to the hot bath with Γ_\downarrow^H . The excitation (\uparrow) and relaxation (\downarrow) rates induced by bath $B = C, H$ satisfy the detailed balance condition,

$$\Gamma_\uparrow^B = e^{-\beta_B \Delta E_B} \Gamma_\downarrow^B. \quad (1)$$

Our suggested cooling cycle (Otto cycle) is as follows, see Figs. 1(a) and 1(b): (i) The system is initially coupled to bath C with level spacing ΔE_C for a time interval δt ($a \rightarrow b$). (ii) The level separation is increased (*abrupt compression*) from ΔE_C to ΔE_H ($b \rightarrow c$). (iii) The system interacts with bath H at ΔE_H for a short time interval δt ($c \rightarrow d$). (iv) The level separation is decreased (*abrupt expansion*) from ΔE_H to ΔE_C ($d \rightarrow a'$). In the analysis below, we find a cyclic steady-state solution for the system state and heat currents, i.e., power, P_C, P_H to the cold and hot baths, respectively. In particular we look for the high frequency $f = 1/(2\delta t) \rightarrow \infty$ solution under different conditions.

This cycle can be realized physically [Fig. 1(c)] by a superconducting qubit [22,23] coupled to the baths C and H via coplanar waveguide resonators with resonance frequencies $\omega_C = \Delta E_C/\hbar$ and $\omega_H = \Delta E_H/\hbar$, respectively [13,24,25]. If the difference between the level separations $|\Delta E_H - \Delta E_C|$ is large enough for a given quality factor Q_B of the resonator, the TLS couples essentially to one bath only at a time and we obtain the presented alternating cycle as will be detailed in the final section of this paper.

III. QUANTUM CYCLE

The cycle described above can be analyzed precisely for a quantum TLS weakly coupled to the baths. Due to piecewise constant and abrupt legs in the cycle, we do not have to resort to possibly uncontrolled master equations under rapid change of the parameters. Instead, we adopt the sudden approximation of quantum mechanics for the (de)compression legs, and the standard Lindbladian evolution [26,27] of the TLS with constant level separation for the thermalization legs over the time intervals δt . We analyze these two different types of evolutions one by one and then find the steady state (cyclic)

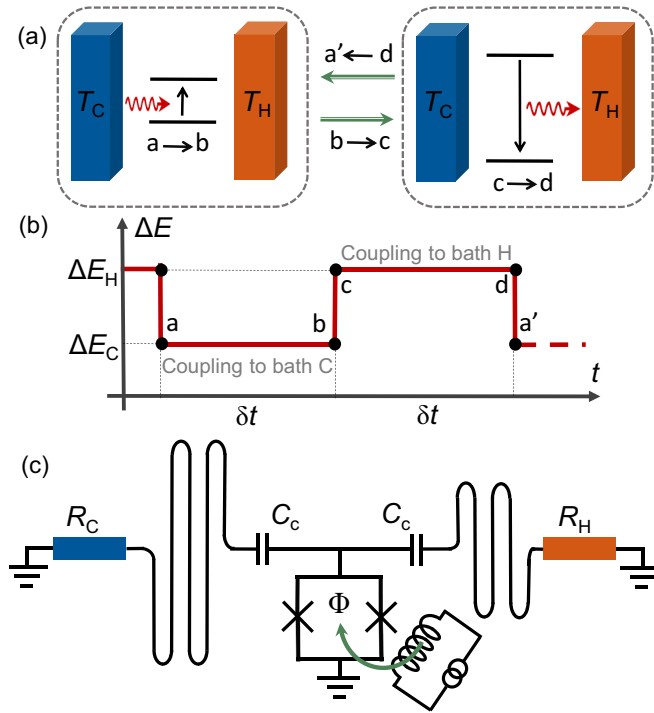

FIG. 1. A two-level system (TLS) coupled to cold and hot baths at temperatures T_C and T_H , respectively. (a) The cooling cycle where the TLS couples alternately to one of the baths at a time. The interaction of the TLS with each bath is controlled by the level separation: For small (large) splitting it exchanges energy with the cold (hot) bath. The green arrows depict the abrupt expansion (compression). (b) The driving protocol in time, demonstrating one cycle of the process in (a). In a sudden cycle $\delta t \rightarrow 0$. (c) Potential experimental realization: the schematic of a superconducting qubit capacitively (C_c) coupled to coplanar wave resonators, operating at two distinct frequencies, and terminated by resistors R_C and R_H acting as the heat baths. The energy separation ΔE of the TLS is tuned according to the protocol in (a) and (b) by applying magnetic flux Φ .

result by imposing continuity of the density matrix in time. The qubit has the Hamiltonian

$$H_Q = -E_0(\Delta\sigma_x + q\sigma_z), \quad (2)$$

where E_0 is the overall energy scale, Δ is the coupling, and q the control parameter (magnetic or electric field). Its eigenstates in the computational basis $|+\rangle = (1\ 0)^\dagger$ and $|-\rangle = (0\ 1)^\dagger$ read

$$\begin{aligned} |g\rangle &= 2^{-1/2}[\sqrt{1-\eta(q)}|-\rangle + \sqrt{1+\eta(q)}|+\rangle], \\ |e\rangle &= 2^{-1/2}[\sqrt{1+\eta(q)}|-\rangle - \sqrt{1-\eta(q)}|+\rangle], \end{aligned} \quad (3)$$

with level separation

$$\Delta E = 2E_0\sqrt{q^2 + \Delta^2}. \quad (4)$$

In Eq. (3), $\eta(q) \equiv (q/\Delta)/\sqrt{1+(q/\Delta)^2}$. We study the evolution of the density matrix ρ parametrized by $\mathcal{D} \equiv \rho_{gg} - 1/2$, $\mathcal{R} \equiv \text{Re}(\rho_{ge}e^{i\phi})$, and $\mathcal{I} \equiv \text{Im}(\rho_{ge}e^{i\phi})$, where $\rho_{gg} = \langle g|\rho|g\rangle$, $\rho_{ge} = \langle g|\rho|e\rangle$, and $\phi = \int dt \Delta E/\hbar$ is the phase that could be accumulated along the thermalization legs. In our discussion below, we assume that this phase is not relevant,

either because the overall operation cycle is so short that ϕ is negligible, or because the thermalization legs are timed so that ϕ is a multiple of 2π . The latter regime can in principle be realized, since the thermalization legs that are short on the relaxation time scale, can be effectively of arbitrary length on the time scale set by the system energies. The relaxation can be neglected during the fast q ramp between $q = 0$ and $q = q_M$, so that the density matrices ρ^i, ρ^f before and after the ramp are connected by a unitary evolution $\rho^f = U\rho^i U^\dagger$. For a sudden ramp $U = I$, i.e., $\rho^f = \rho^i$. The eigenstates of the initial and final Hamiltonians of the ramp $q: 0 \rightarrow q_M$ is obtained by substituting $q = 0$ and $q = q_M$, in Eq. (3), respectively. In this ramp, the elements of the final density matrix in the basis of the final Hamiltonian ($\{|g_f\rangle, |e_f\rangle\}$) can be written as $\rho_{kl}^f \equiv \langle k|\rho^f|l\rangle = \langle k|\rho^i|l\rangle = \sum_{k'l'} \rho_{k'l'}^i \langle k|k'\rangle \langle l'|l\rangle$, where $|k\rangle(|l\rangle)$ denotes the eigenstates of the final Hamiltonian and $|k'\rangle(|l'\rangle)$ represents the eigenstates of the initial Hamiltonian. Hence, during q ramps: $0 \rightarrow q_M$ ($b \rightarrow c$), the elements of the final and the initial density matrices in the basis of their respective instantaneous Hamiltonians are related as

$$\begin{aligned} \mathcal{D}_c &= \sqrt{1 - \eta_M^2} \mathcal{D}_b - \eta_M \mathcal{R}_b, \\ \mathcal{R}_c &= \sqrt{1 - \eta_M^2} \mathcal{R}_b + \eta_M \mathcal{D}_b, \end{aligned} \quad (5)$$

where $\eta_M \equiv \eta(q_M)$. Similar analysis can also be made for the ramp $q_M \rightarrow 0$ ($d \rightarrow a'$). For assumed real Δ , the imaginary part $\mathcal{I} \equiv \text{Im}(\rho_{ge}e^{i\phi})$ remains constant in these ramps.

For the (partial) thermalization parts of the cycle between the sudden legs $q = \text{const}$, only the relaxation drives the TLS evolution, i.e., according to the standard master equation we have

$$\dot{\rho}_{gg} = -\Gamma_\Sigma^B \rho_{gg} + \Gamma_\downarrow^B, \quad \dot{\rho}_{ge} = -\frac{1}{2}\Gamma_\Sigma^B \rho_{ge}, \quad (6)$$

where $\Gamma_\Sigma^B \equiv \Gamma_\downarrow^B + \Gamma_\uparrow^B$. In the limit of short thermalization time δt , we may then write with analogous notations as for the sudden leg,

$$\begin{aligned} \mathcal{D}_f &= \mathcal{D}_i + [\Gamma_\downarrow^B - \Gamma_\Sigma^B(\mathcal{D}_i + 1/2)]\delta t, \\ \mathcal{R}_f &= (1 - \frac{1}{2}\Gamma_\Sigma^B \delta t)\mathcal{R}_i, \quad \mathcal{I}_f = (1 - \frac{1}{2}\Gamma_\Sigma^B \delta t)\mathcal{I}_i. \end{aligned} \quad (7)$$

Equation (7), together with the fact that $\dot{\mathcal{I}} = 0$ in the sudden legs, implies that $\mathcal{I} \equiv 0$ in a limit cycle.

Next, we combine all the four legs in the cycle assuming the steady-state situation when the system returns to the same state after each driving period (limit cycle $\rho_{a'} = \rho_a$), obtaining a set of equations as

$$\begin{aligned} \mathcal{D}_b &= \mathcal{D}_a + [\Gamma_\downarrow^C - \Gamma_\Sigma^C(\mathcal{D}_a + 1/2)]\delta t, \\ \mathcal{R}_b &= (1 - \frac{1}{2}\Gamma_\Sigma^C \delta t)\mathcal{R}_a, \\ \mathcal{D}_c &= \sqrt{1 - \eta_M^2} \mathcal{D}_b - \eta_M \mathcal{R}_b, \quad \mathcal{R}_c = \sqrt{1 - \eta_M^2} \mathcal{R}_b + \eta_M \mathcal{D}_b, \\ \mathcal{D}_d &= \mathcal{D}_c + [\Gamma_\downarrow^H - \Gamma_\Sigma^H(\mathcal{D}_c + 1/2)]\delta t, \\ \mathcal{R}_d &= (1 - \frac{1}{2}\Gamma_\Sigma^H \delta t)\mathcal{R}_c, \\ \mathcal{D}_a &= \sqrt{1 - \eta_M^2} \mathcal{D}_d + \eta_M \mathcal{R}_d, \quad \mathcal{R}_a = \sqrt{1 - \eta_M^2} \mathcal{R}_d - \eta_M \mathcal{D}_d. \end{aligned} \quad (8)$$

Heat currents to the cold $P_C = \Delta E_C(\mathcal{D}_b - \mathcal{D}_a)/(2\delta t)$ and hot $P_H = \Delta E_H(\mathcal{D}_d - \mathcal{D}_c)/(2\delta t)$ baths are then given for $q_M/\Delta \gg 1$ by

$$P_{C(H)} = \Delta E_{C(H)} \frac{\Gamma_{\downarrow}^{C(H)} \Gamma_{\Sigma}^{H(C)} (1 - e^{-\beta_{C(H)} \Delta E_{C(H)}})}{4(2\Gamma_{\Sigma}^{C(H)} + \Gamma_{\Sigma}^{H(C)})} > 0. \quad (9)$$

Thus in this limit both baths are heated. As discussed below, this is a manifestation of the adverse effect of coherence on the performance of a quantum refrigerator. Based on Eq. (8), the heat currents to the cold and the hot baths can also be written for $\eta_M \approx 1$ as $P_C = \Delta E_C(\mathcal{R}_c - \mathcal{R}_d)/(2\delta t) = \Delta E_C \Gamma_{\Sigma}^H \mathcal{R}_c/4$ and $P_H = \Delta E_H(\mathcal{R}_b - \mathcal{R}_a)/(2\delta t) = -\Delta E_H \Gamma_{\Sigma}^C \mathcal{R}_a/4$, showing an explicit relation between heat power and coherence. The lowest order correction to $P_{C(H)}$ in Δ/q_M , $\delta P_{C(H)} = \gamma_{C(H)} \Delta/q_M$, is obtained with

$$\gamma_{C(H)} = -\Delta E_{C(H)} \frac{(\Gamma_{\downarrow}^{H(C)} - \Gamma_{\uparrow}^{H(C)}) \Gamma_{\Sigma}^{C(H)} (\Gamma_{\Sigma}^C + \Gamma_{\Sigma}^H)}{2(2\Gamma_{\Sigma}^C + \Gamma_{\Sigma}^H)(2\Gamma_{\Sigma}^H + \Gamma_{\Sigma}^C)}.$$

IV. INCOHERENT OTTO REFRIGERATOR

For an incoherent system, we assume a diagonal density matrix whose evolution is governed by the rate equation for the ground state population $\rho_{gg} = 1 - \rho_{ee}$ as

$$\dot{\rho}_{gg} = \rho_{ee} \Gamma_{\downarrow}^B - \rho_{gg} \Gamma_{\uparrow}^B = \Gamma_{\downarrow}^B - \Gamma_{\Sigma}^B \rho_{gg}. \quad (10)$$

Such dynamics can be realized for instance using a classical single-electron box as a TLS [28]. For infinitely fast expansion and compression, ρ again remains constant. Yet in the thermalization legs of infinitesimal duration $\Gamma_{\Sigma}^B \delta t \ll 1$, the population changes according to Eq. (10) as

$$\rho_{gg}(\delta t) - \rho_{gg}(0) = [\Gamma_{\downarrow}^B - \Gamma_{\Sigma}^B \rho_{gg}(0)] \delta t. \quad (11)$$

Here we have set the initial time in each thermalization leg to zero. In this situation the populations in the limit cycle are governed by

$$\begin{aligned} \mathcal{D}_b &= \mathcal{D}_a + [\Gamma_{\downarrow}^C - \Gamma_{\Sigma}^C(\mathcal{D}_a + 1/2)] \delta t, & \mathcal{D}_c &= \mathcal{D}_b, \\ \mathcal{D}_d &= \mathcal{D}_c + [\Gamma_{\downarrow}^H - \Gamma_{\Sigma}^H(\mathcal{D}_c + 1/2)] \delta t, & \mathcal{D}_a &= \mathcal{D}_d, \end{aligned} \quad (12)$$

where \mathcal{D}_i denotes the shifted ground state population $\rho_{gg} - 1/2$, as before, at position $i = a, b, c, d$ in the cycle. We obtain in the linear order in δt , $\Delta \mathcal{D} = \mathcal{D}_b - \mathcal{D}_a = \mathcal{D}_c - \mathcal{D}_d = (\Gamma_{\downarrow}^C \Gamma_{\uparrow}^H - \Gamma_{\uparrow}^C \Gamma_{\downarrow}^H) \delta t / (\Gamma_{\Sigma}^C + \Gamma_{\Sigma}^H)$. From the detailed balance conditions (1), the average power to the baths $P_{C(H)} = \pm \Delta \mathcal{D} \Delta E_{C(H)} f$ is then

$$P_{C(H)} = \frac{1}{2} \frac{\Gamma_{\downarrow}^C \Gamma_{\downarrow}^H}{\Gamma_{\Sigma}^C + \Gamma_{\Sigma}^H} \times (e^{-\beta_{C(H)} \Delta E_{C(H)}} - e^{-\beta_{C(H)} \Delta E_{C(H)}}) \Delta E_{C(H)}. \quad (13)$$

One can see immediately from Eq. (13) that for equal temperatures $\beta \equiv \beta_C = \beta_H$ and setting $\Delta E_H > \Delta E_C$,

$$P_C < 0 \text{ and } P_H > 0, \quad (14)$$

meaning that the bath to which the system couples at lower level splitting cools down, whereas that with higher energy separation heats up. Equation (14) is generally true for different temperatures when $\beta_H \Delta E_H > \beta_C \Delta E_C$. Thus

incoherent dynamics leads to refrigeration even in sudden cycles. The coefficient of performance of the refrigerator is $\epsilon \equiv$ extracted heat/work $= -P_C/(P_C + P_H)$. Based on Eq. (13), in the sudden limit it is

$$\epsilon = \frac{\Delta E_C}{\Delta E_H - \Delta E_C}, \quad (15)$$

which is precisely the same as for an ideal low frequency Otto cycle.

The expression of powers to the cold and hot baths can be further simplified if $\beta \Delta E \gg 1$ and assuming that the excitation when coupled to the cold bath presents the slowest rate. In this case $P_C = -\Gamma_{\uparrow}^C \Delta E_C/2$.

V. COHERENCE GENERATES DISSIPATION

The adverse effect of quantum coherence on refrigeration in our model can be further illustrated by the following considerations. Assume that a TLS starts from a state with the density matrix ρ diagonal in the energy basis, and the occupation probability P_{ee} of the excited state is smaller than the probability of the ground state. If it is then driven by a changing external control parameter, the final state of the system is $\rho' = U \rho U^\dagger$, where U is the unitary evolution operator. Coherence can be created between the eigenstates of the final Hamiltonian if the system Hamiltonian does not commute at different time instances $[H(t), H(t')] \neq 0$. One can directly show that creation of the coherence in the final state, which depends upon the rate of driving, implies that the occupation probability of the excited state $P'_{ee} = \langle e' | \rho' | e' \rangle$ at the end of the evolution ($|e'\rangle$ is the excited state of the final Hamiltonian) is higher than the initial P_{ee} . On the other hand, for an infinitely slow process, the quantum adiabatic theorem holds and hence no coherence will be created, i.e., the populations in the energy eigenstates remain unchanged. Therefore, in general, the final energy of a system which is driven fast is higher than that of a slowly driven system. This difference of energy can be interpreted as the cost of creating coherence. Furthermore, if this system is allowed to interact with a heat bath, decoherence takes place, and the extra energy spent to create the coherence will be dissipated to the heat bath. In quantum thermodynamics, this phenomenon is often called *inner or intrinsic* friction [15]. It has been studied in different contexts [16,29,30], and can be viewed as the reason for the failure of the quantum refrigerator in the high-frequency limit.

The populations in the instantaneous eigenstates of the Hamiltonian change under fast driving due to the creation of coherence. For example, \mathcal{D}_c is different from \mathcal{D}_b due to the sudden ramp in Eq. (8). There are ‘‘shortcut to adiabaticity’’ protocols to keep the populations unchanged during fast processes [31–35]. The eigenvectors of the quantum TLS in Eq. (3) are q dependent. Therefore, when q is varied in time, eigenvectors become time dependent which in turn creates coherence during the sudden cycle. As we have seen, creation of coherence affects refrigeration adversely. To suppress the creation of quantum coherence, we can use a simple and experimentally feasible technique [16]: We may envision a cycle, in which q and Δ are varied in time such that their ratio remains constant throughout the cycle. Since the energy

eigenstates ($|g\rangle$, $|e\rangle$) in Eq. (3) are functions of q/Δ , they become time independent and hence no coherence will be created, but varying the parameters q and Δ changes the energy level spacing [Eq. (4)]. Since the density matrix in this protocol remains diagonal, the time evolution of the TLS is governed by Eqs. (10) and (11) as in the classical regime. Therefore, the refrigeration is restored and is described by the same Eqs. (13)–(15) as above. The basic shortcuts to adiabaticity involve compensating fields that are proportional to the time derivative of q [32]. This means infinite fields for sudden cycles, which is infeasible for experimental realization. On the contrary, the protocol we propose above (constant q/Δ) avoids this problem making it experimentally attractive. This can be realized for instance by tuning simultaneously magnetic flux and gate voltage in a charge qubit configuration [23,36].

VI. EXPERIMENTAL FEASIBILITY AND DISCUSSION

Figure 1(c) presents an experimental setup proposed for realizing a four-stroke quantum refrigerator [13] that has been tested under steady-state conditions experimentally in Ref. [24]. In this circuit the alternating coupling between the two baths, resistors R_C and R_H , is achieved thanks to the two LC resonators with different frequencies $f_B = \omega_B/(2\pi) = \Delta E_B/h$, $B = C, H$. The rate of emitting a photon to bath B for a TLS with level separation ΔE is then obtained from the standard golden rule expression as [13]

$$\Gamma_{\downarrow}^B = \kappa_B \frac{\Delta^2}{q^2 + \Delta^2} \frac{\Delta E/h}{(1 - e^{-\beta_B \Delta E})} \times [1 + Q_B^2 (\Delta E/\Delta E_B - \Delta E_B/\Delta E)^2]^{-1}. \quad (16)$$

Here κ_B is the dimensionless coupling parameter between the qubit and the resonator, and Q_B is the quality factor of the lossy resonator B. In Eq. (16), the q -dependent coupling of noise is governed by $\Delta^2/(q^2 + \Delta^2)$, the Lorentzian Q_B dependent denominator determines the LC -filtered bandpass of the coupling, and $\Delta E/(1 - e^{-\beta_B \Delta E})$ is due to the bare thermal noise of the resistor. Thus, making the quality factor of the resonators Q_B much larger in comparison to $\Delta E_C/(\Delta E_H - \Delta E_C)$, the TLS couples essentially to one bath only at a time which helps us to ignore the possibilities of any unexpected behavior due to different noise sources [37,38]. This condition can be met for any $Q_B \gg 1$, unless the two resonators are nearly identical. The regime we discuss, the “sudden limit,” can be reached by operating at frequencies $f \gg \Gamma$, where Γ can be approximated by Eq. (16) at resonance. This condition can be controlled by setting the coupling κ_B between the qubit and the resonator weak enough. Since this

coupling is either capacitive or inductive in a superconducting qubit, it can be down-tuned by geometry of the device. Typical numbers for superconducting (transmon) qubits are in the range of $\kappa_B \sim 10^{-2}$ [22,24]. For order of magnitude estimates, we may assume that the typical rates in Eq. (16) are $\Gamma \sim \kappa_B \Delta E/h$ at resonance. For a realistic level spacing of $\Delta E/k_B = 0.1$ K, and κ_B cited above, we have $\Gamma \sim 100$ MHz; $f > 100$ MHz can be easily achieved in the experiment. In this situation, the typical powers, based on Eqs. (9) and (13), are of the order of $P_B \sim \Gamma \Delta E \sim 10^{-16}$ W, which is about one to two orders higher than the experimental noise equivalent power achieved by standard bolometric techniques [24]. What is usually considered as the limit of validity of Markovian analysis, as presented here, is that the bath correlation time needs to be shorter than the inverse decay rates of the quantum system. This is achieved by down-tuning the qubit relaxation rates at resonance to below the typical electron-electron collision rate in metal absorbers and the inverse resonator linewidth Q_B/ω_B , which both are $> 10^9$ Hz, corresponding to the relevant correlation time. It is to be noted that the equations for the evolution of the density matrix we use are applicable to any equilibrium reservoir regardless of its microscopic nature, as long as f does not exceed $\Delta E/h$. In this respect, our model is based on a fully realistic description of the heat baths.

In conclusion, we have demonstrated sudden cooling cycles for both classical and quantum systems. Quantum cycles lead to dissipation due to coherence generation. Yet refrigeration can be resumed by mimicking classical dynamics via a simple driving protocol, where the instantaneous eigenstates do not vary during the operation. Implementing the tunable coupling to the baths can turn out to be more challenging for a classical TLS [39], since the diagonal evolution comes then at the cost of adding an uncontrollable decoherence path. Therefore, we propose that it is an advantage to use a quantum TLS avoiding coherences as explained. We present a realistic setup based on superconducting circuit quantum electrodynamics platform to test our predictions experimentally.

ACKNOWLEDGMENTS

We acknowledge M. Möttönen, K. Funo, and M. Moskalets for useful discussions. This work was funded through Academy of Finland Grants No. 312057 and No. 303677 and from the European Union’s Horizon 2020 research and innovation programme under the European Research Council (ERC) programme and Marie Skłodowska-Curie actions (Grant agreements No. 742559 and No. 766025). G.T. thanks for the grant from the Centre for Quantum Engineering at Aalto University. D.V.A. is supported by the US NSF Grant No. DMR-1836707.

- [1] R. Alicki, The quantum open system as a model of the heat engine, *J. Phys. A: Math. Gen.* **12**, L103 (1979).
- [2] R. Uzdin, A. Levy, and R. Kosloff, Equivalence of Quantum Heat Machines, and Quantum-Thermodynamic Signatures, *Phys. Rev. X* **5**, 031044 (2015).
- [3] S. Vinjanampathy and J. Anders, Quantum thermodynamics, *Contemp. Phys.* **57**, 545 (2016).

- [4] M. O. Scully, M. S. Zubairy, G. S. Agarwal, and H. Walther, Extracting Work from a single heat bath via vanishing quantum coherence, *Science* **299**, 862 (2003).
- [5] M. O. Scully, K. R. Chapin, K. E. Dorfman, M. B. Kim, and A. Svidzinsky, Quantum heat engine power can be increased by noise-induced coherence, *Proc. Natl. Acad. Sci. USA* **108**, 15097 (2011).

- [6] S. Rahav, U. Harbola, and S. Mukamel, Heat fluctuations and coherences in a quantum heat engine, *Phys. Rev. A* **86**, 043843 (2012).
- [7] A. Streltsov, G. Adesso, and M. B. Plenio, Colloquium: Quantum coherence as a resource, *Rev. Mod. Phys.* **89**, 041003 (2017).
- [8] J. Jaramillo, M. Beau, and A. del Campo, Quantum supremacy of many-particle thermal machines, *New J. Phys.* **18**, 075019 (2016).
- [9] P. P. Hofer, M. Perarnau-Llobet, J. B. Brask, R. Silva, M. Huber, and N. Brunner, Autonomous quantum refrigerator in a circuit QED architecture based on a Josephson junction, *Phys. Rev. B* **94**, 235420 (2016).
- [10] V. Holubec and T. Novotný, Effects of noise-induced coherence on the performance of quantum absorption refrigerators, *J. Low Temp. Phys.* **192**, 147 (2018).
- [11] P. A. Camati, J. F. G. Santos, and R. M. Serra, Employing coherence to improve the performance of a quantum heat engine, *Phys. Rev. A* **99**, 062103 (2019).
- [12] M. Kilgour and D. Segal, Coherence and decoherence in quantum absorption refrigerators, *Phys. Rev. E* **98**, 012117 (2018).
- [13] B. Karimi and J. P. Pekola, Otto refrigerator based on a superconducting qubit: Classical and quantum performance, *Phys. Rev. B* **94**, 184503 (2016).
- [14] K. Brandner and U. Seifert, Periodic thermodynamics of open quantum systems, *Phys. Rev. E* **93**, 062134 (2016).
- [15] R. Kosloff and T. Feldmann, Discrete four-stroke quantum heat engine exploring the origin of friction, *Phys. Rev. E* **65**, 055102(R) (2002).
- [16] G. Thomas and R. S. Johal, Friction due to inhomogeneous driving of coupled spins in a quantum heat engine, *Eur. Phys. J. B* **87**, 166 (2014).
- [17] J.-Y. Du and F.-L. Zhang, Nonequilibrium quantum absorption refrigerator, *New J. Phys.* **20**, 063005 (2018).
- [18] P. A. Erdman, V. Cavina, R. Fazio, F. Taddei, and V. Giovannetti, Maximum power and corresponding efficiency for two-level quantum heat engines and refrigerators, [arXiv:1812.05089](https://arxiv.org/abs/1812.05089).
- [19] T. Feldmann and R. Kosloff, Performance of discrete heat engines and heat pumps in finite time, *Phys. Rev. E* **61**, 4774 (2000).
- [20] D. Newman, F. Mintert, and A. Nazir, Performance of a quantum heat engine at strong reservoir coupling, *Phys. Rev. E* **95**, 032139 (2017).
- [21] T. Feldmann and R. Kosloff, Transitions between refrigeration regions in extremely short quantum cycles, *Phys. Rev. E* **93**, 052150 (2016).
- [22] J. Koch, T. M. Yu, J. Gambetta, A. A. Houck, D. I. Schuster, J. Majer, A. Blais, M. H. Devoret, S. M. Girvin, and R. J. Schoelkopf, Charge-insensitive qubit design derived from the Cooper pair box, *Phys. Rev. A* **76**, 042319 (2007).
- [23] J. Clarke and F. K. Wilhelm, Superconducting quantum bits, *Nature (London)* **453**, 1031 (2008).
- [24] A. Ronzani, B. Karimi, J. Senior, Y. C. Chang, J. T. Peltonen, C. D. Chen, and J. P. Pekola, Tunable photonic heat transport in a quantum heat valve, *Nat. Phys.* **14**, 991 (2018).
- [25] M. J. Henrich, G. Mahler, and M. Michel, Small quantum networks operating as quantum thermodynamic machines, *Europhys. Lett.* **76**, 1057 (2006).
- [26] H.-P. Breuer and F. Petruccione, *The Theory of Open Quantum Systems* (Oxford University Press, Oxford, 2002).
- [27] J. P. Pekola, V. Brosco, M. Möttönen, P. Solinas, and A. Shnirman, Decoherence in Adiabatic Quantum Evolution: Application to Cooper Pair Pumping, *Phys. Rev. Lett.* **105**, 030401 (2010).
- [28] D. V. Averin and J. P. Pekola, Statistics of the dissipated energy in driven single-electron transitions, *Europhys. Lett.* **96**, 67004 (2011).
- [29] A. Alecce, F. Galve, N. Lo Gullo, L. Dell'Anna, F. Plastina, and R. Zambrini, Quantum Otto cycle with inner friction: finite-time and disorder effects, *New J. Phys.* **17**, 075007 (2015).
- [30] S. Deng, A. Chenu, P. Diao, F. Li, S. Yu, I. Coulamy, A. del Campo, and H. Wu, Superadiabatic quantum friction suppression in finite-time thermodynamics, *Sci. Adv.* **4**, 5909 (2018).
- [31] X. Chen, A. Ruschhaupt, S. Schmidt, A. del Campo, D. Guéry-Odelin, and J. G. Muga, Fast Optimal Frictionless Atom Cooling in Harmonic Traps: Shortcut to Adiabaticity, *Phys. Rev. Lett.* **104**, 063002 (2010).
- [32] M. G. Bason, M. Viteau, N. Malossi, P. Huillery, E. Arimondo, D. Ciampini, R. Fazio, V. Giovannetti, R. Mannella, and O. Morsch, High-fidelity quantum driving, *Nat. Phys.* **8**, 147 (2012).
- [33] S. Deffner, C. Jarzynski, and A. del Campo, Classical and Quantum Shortcuts to Adiabaticity for Scale-Invariant Driving, *Phys. Rev. X* **4**, 021013 (2014).
- [34] O. Abah and E. Lutz, Performance of shortcut-to-adiabaticity quantum engines, *Phys. Rev. E* **98**, 032121 (2018).
- [35] Z. Zhang *et al.*, Experimental demonstration of work fluctuations along a shortcut to adiabaticity with a superconducting Xmon qubit, *New J. Phys.* **20**, 085001 (2018).
- [36] Y. Makhlin, G. Schön, and A. Shnirman, Quantum-state engineering with Josephson junction devices, *Rev. Mod. Phys.* **73**, 357 (2001).
- [37] A. H. Castro Neto, E. Novais, L. Borda, G. Zaránd, and I. Affleck, Quantum Magnetic Impurities in Magnetically Ordered Systems, *Phys. Rev. Lett.* **91**, 096401 (2003).
- [38] T. Palm and P. Nalbach, Nonperturbative environmental influence on dephasing, *Phys. Rev. A* **96**, 032105 (2017).
- [39] J. V. Koski, A. Kutvonen, I. M. Khaymovich, T. Ala-Nissila, and J. P. Pekola, On-chip Maxwell's Demon As an Information-Powered Refrigerator, *Phys. Rev. Lett.* **115**, 260602 (2015).