

## Thermally assisted photoemission effect on CeB<sub>6</sub> and LaB<sub>6</sub> for application as photocathodes

K. Torgasin,\* K. Morita, H. Zen, K. Masuda, T. Katsurayama, T. Murata, S. Suphakul, H. Yamashita, T. Nogi, T. Kii, K. Nagasaki, and H. Ohgaki

*Institute of Advanced Energy, Kyoto University, 611-0011 Uji, Japan*

(Received 16 October 2016; published 25 July 2017)

The thermally assisted photoemission (TAPE) effect was investigated for the hexaboride thermionic cathodes (LaB<sub>6</sub> and CeB<sub>6</sub>). It was found that the quantum efficiency of these cathodes can be increased by raising the cathode temperature along with the thermionic emission. In addition both materials can emit a measurable photoemission current by being irradiated with a laser having a photon energy below the work function at sufficiently high cathode temperatures. Our measurements indicate that this process is linear. These results show the significance of the TAPE effect. An additional effect of cathode heating is surface cleaning. This effect was detected as the hysteresis of the quantum efficiency which can be observed by heating up and cooling down the cathode. This effect slightly changes the quantum efficiency but not as much as the TAPE effect.

DOI: 10.1103/PhysRevAccelBeams.20.073401

### I. INTRODUCTION

Thermionic and photoelectron injectors are widely adopted in FEL facilities. The use of photocathodes for the generation of high brightness electron beams has the advantages of a high peak current and flexible control of emission timing; however, in some cases it has the disadvantages of high sensitivity to vacuum conditions and short lifetime. Very high quantum efficiency (QE) > 1%, semiconductor photocathodes such as Cs<sub>2</sub>Te, CsK<sub>2</sub>Sb, and GaAs, require an extremely high vacuum to keep the quantum efficiency for a long time. On the other hand, low quantum efficiency (0.001%–0.01%) materials such as metal and metal compound photocathodes usually have long lifetimes but require lasers with high pulse energy which increases costs [1]. The main target for further photocathode development is to increase the lifetime of high QE materials or to increase the QE for robust materials. Thermionic cathode materials have already been applied as robust photocathodes in rf guns. Tungsten dispenser cathodes were reported to be suitable for operation in photoinjectors [2,3]. Also LaB<sub>6</sub> cathodes have already been successfully used as photocathodes [4–8].

In this work we investigate the possibility of increasing the QE of thermionic cathode materials using a thermally assisted photoemission (TAPE) process. Thermal excitation changes the energy distribution of electrons in materials as

shown in Fig. 1. By heating up a cathode, electrons can obtain a higher energy state than the work function and can then be extracted via thermionic current. The corresponding thermionic current density on the cathode has been described by Richardson-Dushman, see equation [9]:

$$j = A_G T^2 \exp\left(-\frac{\varphi}{k_B T}\right),$$

where  $\varphi$  is the work function in eV,  $k_B$  is Boltzmann constant and  $T$  is the cathode temperature in Kelvin.  $A_G = \lambda_B(1-r)A_0$  is the generalized Richardson constant, which contains  $r$ , the averaged quantum-mechanical reflection,  $\lambda_B$ , the band structure related correction factor, and  $A_0$ , the universal Richardson constant ( $=1.20173 \times 10^6 \text{ Am}^{-2} \text{ K}^{-2}$ ).

The TAPE effect makes use of thermionic excitation in order to change the energy distribution of electrons in cathode materials. Due to thermal excitation some electrons occupy higher energetic states, which increases the probability of extraction by photon and the energy of the extracted

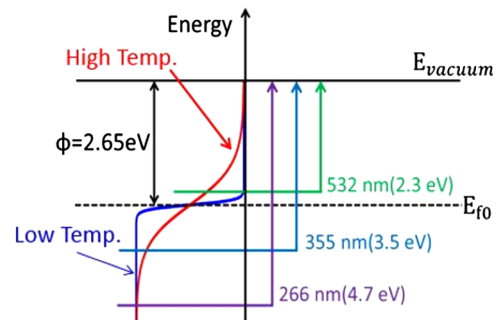

FIG. 1. Energy diagram schematic of thermally assisted photoemission (TAPE).

\*stone@iae.kyoto-u.ac.jp

TABLE I. Summary of cathode material properties. Additionally, the correspondence of excitation laser wavelengths and photon energy [12].

	CeB <sub>6</sub>	LaB <sub>6</sub>
Generalized Richardson constant $A_G$ (A cm <sup>-2</sup> K <sup>-2</sup> )	3.6	29
Melting point (K)	2463	2483
Work function $\phi$ (eV)	2.65	2.7
Photon energy of excitation wavelength	Wavelength	Photon energy
	266 nm	4.66 eV
	355 nm	3.49 eV
	532 nm	2.33 eV

electrons. Thus the quantum efficiency can be increased by thermal excitation.

Metal hexaborides have been investigated as a cathode material. Since invention in 1950 by Lafferty [10] metal-hexaboride materials have gained high significance for thermionic cathodes, due to a low work function, high melting temperature, high emission current, compared to other thermionic cathodes, and low evaporation rate [11].

In this study we focus on two representative hexaboride thermionic cathode materials, LaB<sub>6</sub> and CeB<sub>6</sub>, and investigate their photoemission properties under various temperature and incident photon energy conditions. Since LaB<sub>6</sub> is already being used as a photocathode, we will compare to CeB<sub>6</sub>.

Table I summarizes the main properties of the two cathodes. One significant difference between them is the generalized Richardson constant indicating higher electron emissivity by LaB<sub>6</sub> for the same temperature. On the other hand, it was reported that CeB<sub>6</sub> has a higher resistivity to carbon contamination and a lower evaporation rate than LaB<sub>6</sub> [13]. Due to its lower evaporation rate, CeB<sub>6</sub> has a longer lifetime than LaB<sub>6</sub> when it is used as a thermionic cathode. Further, the CeB<sub>6</sub> and LaB<sub>6</sub> materials have similar

optical properties [14]. Regarding photoexcitation, QEs of both materials were also reported to be the same at 1300 K for excitation at 266 and 355 nm [6]. These results suggest that the generalized Richardson constant does not affect the photoemission processes. However, these QEs refer to low cathode temperature ( $\sim 1300$  K) measurement. In this study we have expanded the heating range ( $< 1800$  K). As a matter of fact the high operating cathode temperature increases the dark current emission in a photocathode rf gun. The dark current measurement would be an issue for a separate study. In this work we focus on the TAPE phenomenon on itself and treat the dark current as the background in data evaluation.

Another point of interest would be the application of the TAPE effect for electron extraction by laser with photon energy below the work function of the cathode material. This process is illustrated in Fig. 1. External cathode heating increases the population of electrons whose energy is above the Fermi level  $E_{f0}$ , and will reduce the photon energy required for electron extraction.

Consideration of emittance and complexity of laser systems are beyond the scope of this paper.

## II. MEASUREMENT SETUP

The measurement setup is shown in Figs. 2(a) and 2(b). The cathode materials were tested under dc conditions. The applied voltage between the cathode and the anode was 1 kV and the electric field about 0.1 MV/m. A nanosecond yttrium-aluminum-garnet (YAG) laser (Surelite II-10, Continuum) with 2 Hz repetition rate and around 5-ns pulse length was used as the laser source. The fundamental wavelength of the laser was 1064 nm. Three laser wavelengths, 532, 355 and 266 nm, were generated by harmonic generation crystals and introduced to the test chamber. The beam diameter of the laser was larger than the cathode diameter, so a small fraction of the beam was selected by an aperture with a diameter of 2.7 mm. By this means we have

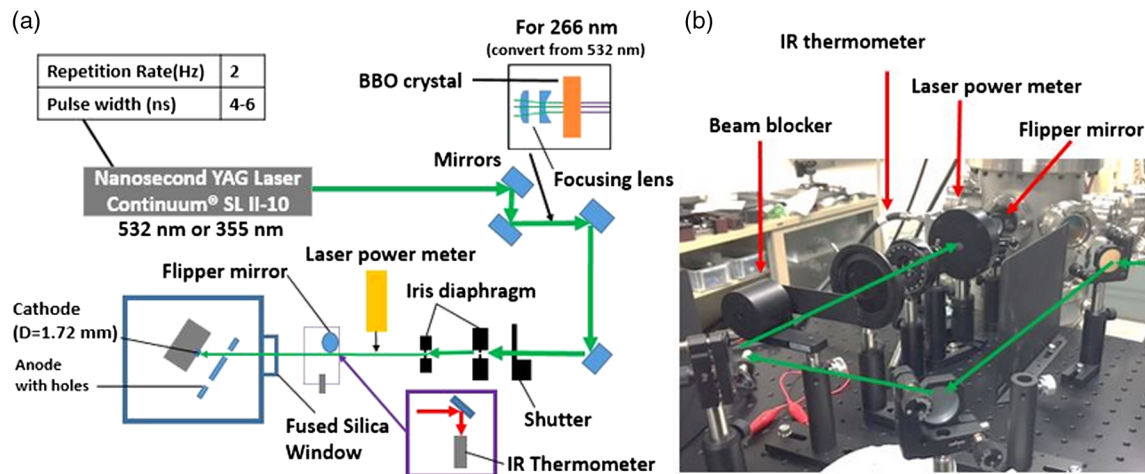

FIG. 2. Experimental setup. (a) Schematic view. (b) Photographic view.

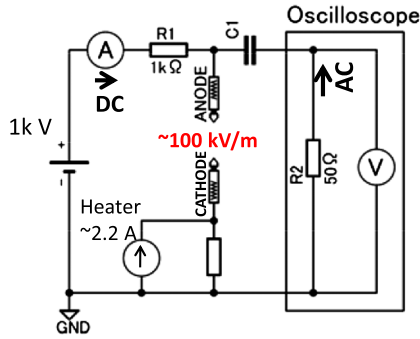

FIG. 3. Equivalent circuit of measurement setup.

reduced intensity variation of the laser profile. The incident laser beam area was kept constant for all measurements and covered the entire cathode. The polarization directions of the laser beams were not measured or controlled. The vacuum level was  $5 \times 10^{-8} - 1 \times 10^{-7}$  Torr. The vacuum conditions showed a slight sensitivity to changes of the cathode temperature and the thermionic current. The cathode temperature was controlled by changing the supplying current to the cathode heater and measured by an IR thermometer. The tested cathodes were single crystals with 1.72 mm diameter in (100) orientation, supplied by Applied Physics Technologies. The equivalent circuit diagram of the measurement setup is shown in Fig. 3. The pulsed photoemission current was ac coupled and measured by an oscilloscope.

By means of ac coupling, the dc thermionic current could be measured separated from the photocurrent by an analogue amperemeter.

### III. RESULTS AND DISCUSSION

The main point of interest is to understand the effects of thermal excitation on the photoemission properties of metal hexaboride materials. Another point is the feasibility of electron extraction by photon energy below the work function of the cathode material using the TAPE effect. Therefore we measure photoemission at different excitation wavelengths, 266, 355 and 532 nm. The correspondence of laser wavelengths and photon energy is given in Table I.

#### A. Thermionic emission of LaB<sub>6</sub> and CeB<sub>6</sub>

Figure 4 shows the thermionic current dependence on cathode temperature. When the cathode temperature was increased to 1478 K, a significant increase of thermionic current from LaB<sub>6</sub> was observed. In the case of CeB<sub>6</sub>, the cathode temperature needed to be increased up to 1550 K.

The measured thermionic current of LaB<sub>6</sub> is higher than that of CeB<sub>6</sub> at the same temperature. Such behavior is attributed to the difference in the generalized Richardson constant (see Table I) and corresponds to previous work [11].

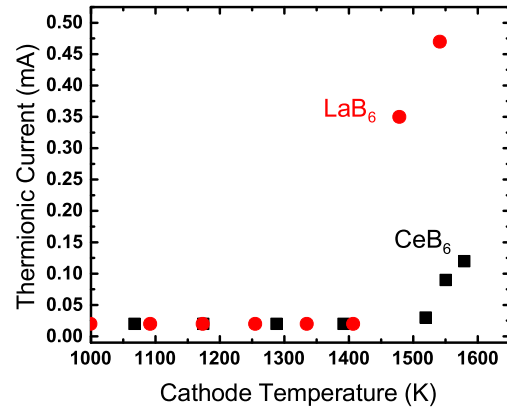
FIG. 4. Thermionic emission from LaB<sub>6</sub> and CeB<sub>6</sub>.

#### B. Photoemission @ 355 nm

In order to compare the photoemission properties of LaB<sub>6</sub> and CeB<sub>6</sub> cathodes, photoemission under different temperature conditions has been tested with the laser wavelength of 355 nm. Figure 5 shows a typical photocurrent pulse signal measured with the LaB<sub>6</sub> cathode.

Typical laser pulse energy in this experiment was around 13  $\mu$ J/pulse. The current was evaluated by integrating the measured voltage pulse over 100 ns. The measured relative quantum efficiency as a function of the cathode temperature is shown in Fig. 6. For comparison, the photoemission current was normalized by laser power and expressed in relative quantum efficiency (QE) by the following relationship:

$$\eta = \frac{\text{number of electrons detected}}{\text{number of incident photons}}.$$

The relative QE is shown to be temperature dependent. This dependency is different for LaB<sub>6</sub> and CeB<sub>6</sub>. The LaB<sub>6</sub> has a higher QE than CeB<sub>6</sub> at the same temperature. This tendency corresponds with thermionic emission.

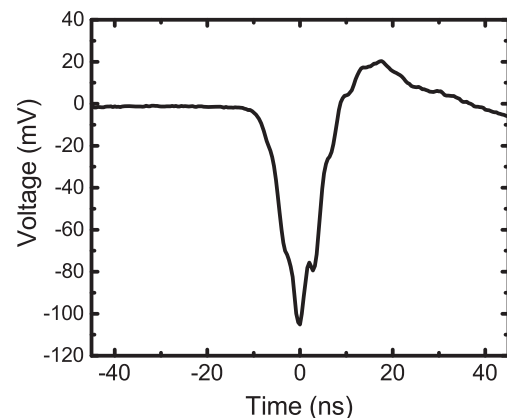
FIG. 5. Photocurrent of LaB<sub>6</sub> by excitation with 355 nm at a cathode temperature of 1400 K.

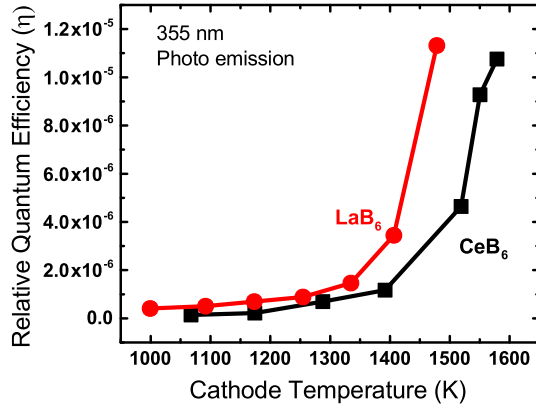

FIG. 6. Photoemission properties of LaB<sub>6</sub> and CeB<sub>6</sub> irradiated by 355 nm.

We conclude that the generalized Richardson constant has an impact on QE, since it indicates the relative difference of the amount of the electrons which reach higher energy levels from thermal excitation.

### C. Quantum efficiency dependence on the cathode temperature at different wavelengths

In order to study the photoemission properties related to the photon energy, LaB<sub>6</sub> was illuminated by laser at three different wavelengths, 266, 355 and 532 nm. There is a slight deviation in QE when measurement is done by heating up and cooling down the cathode. This phenomenon is assigned to the change of surface conditions. In order to compare QE at different wavelengths with similar surface conditions the data acquired by changing the cathode heating from lower to higher temperatures are shown in Fig. 7. The influence of surface condition changes on the QE is discussed in Sec. III E.

The data for 266 nm in Fig. 7 is shown with triangular and diamond symbols which do correspond to different

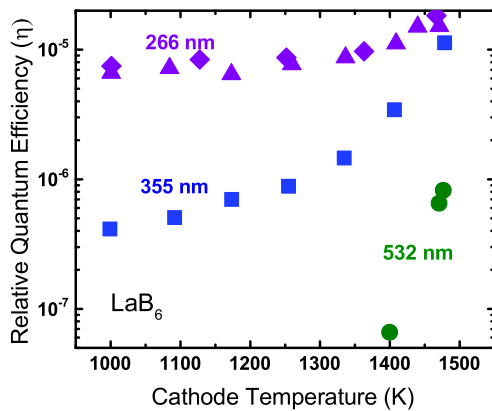

FIG. 7. Results of relative quantum efficiency measurement of LaB<sub>6</sub> cathode being irradiated at three different laser wavelengths, 266, 355 and 532 nm, measured by heating up the cathode.

measurement sets. The two sets are in good agreement. The highest photon energy (4.66 eV @ 266 nm) shows the smallest dependency on cathode temperature. This behavior indicates that the effect of thermal excitation is small when using photons with higher energy. However, the effect is not negligible regarding laser energy requirement. As shown in Fig. 7, electrons could be extracted using 532 nm photons whose energy (2.33 eV @ 532 nm) is below the work function (2.65 eV) if the cathode temperature is higher than 1400 K. For low photon energies special care should be taken to separate the thermionic current from the photocurrent. As mentioned in the setup section, the thermionic dc current and pulsed photocurrent are measured separately. The background is measured under beam blocked conditions and subtracted from the detected photocurrent signal. Nevertheless, the laser pulse may increase the cathode temperature temporally with subsequent pulsed thermionic emission.

Thus the detected photocurrent may contain a fraction from thermionic current. In order to estimate potential impact of pulsed cathode heating we use a 1D heat transfer model.

Figure 8 shows the calculated pulsed heating of LaB<sub>6</sub> for the cathode temperature of 1500 K for several laser pulse energies. The data presented in Fig. 7 for 532 nm excitation was recorded with pulse energy of  $\sim 32 \mu\text{J}$ , which corresponds to additional heating of  $\sim 12 \text{ K}$ .

Comparing with Fig. 4 the corresponded thermionic current increase has an order of  $10^{-2} \text{ mA}$ . Since CeB<sub>6</sub> has a lower electron emission rate at the same cathode temperature, the impact of pulsed thermionic current is lower.

Figures 9(a) and 9(b) shows thermionic and corresponded photocurrent for LaB<sub>6</sub> and CeB<sub>6</sub> for irradiation at 355 and 532 nm. The values of the photocurrent correspond to the maximal measured current, whereas it does not represent the peak current since our detection system is not fast enough to detect 5 ns signal. The thermionic current from the pulsed heating is negligible.

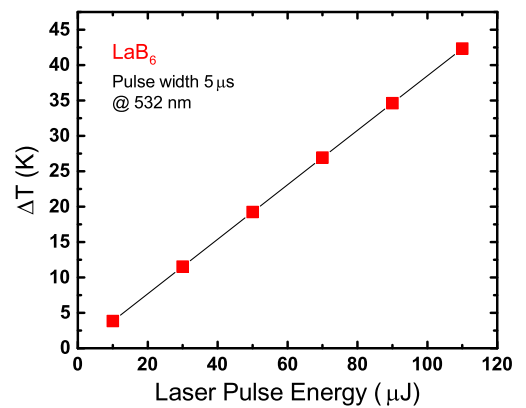

FIG. 8. Calculation of cathode temperature rise by incident laser pulse energy. Cathode material LaB<sub>6</sub> at 1500 K. Laser wavelength 532 nm.

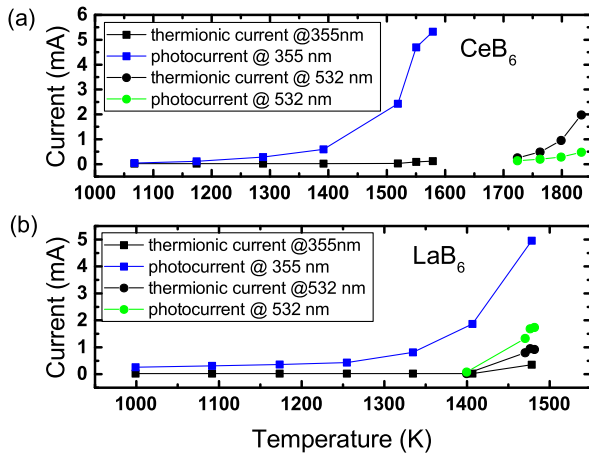

FIG. 9. Thermionic and photocurrent for different cathode temperatures: (a) CeB<sub>6</sub> for excitation by laser of 355 nm at 12  $\mu$ J and of 532 nm at  $\sim$ 84  $\mu$ J; (b) LaB<sub>6</sub> for excitation by laser of 355 nm at  $\sim$ 13  $\mu$ J and of 532 nm at  $\sim$ 32  $\mu$ J.

For the 355 nm wavelength, the photocurrent is significantly higher than the thermionic current for both materials. For the 532 nm wavelength, the CeB<sub>6</sub> generates a lower photocurrent even at a high laser pulse energy ( $\sim$ 84  $\mu$ J). The estimated pulsed heating current is an order below the measured photocurrent. Since the error associated with measured photocurrent is less than 10%, the result represents the real photocurrent.

The photocurrent extraction by illumination at 532 nm demonstrates that TAPE for both materials below the work function is feasible.

Measurements of relative QE at several irradiation wavelengths for CeB<sub>6</sub> are shown in Fig. 10. The different symbols used for representation of relative QE at the same wavelength correspond to different measurement sets. Deviation between the measurement sets can be accounted for measurement error. Comparing photoemission at 266

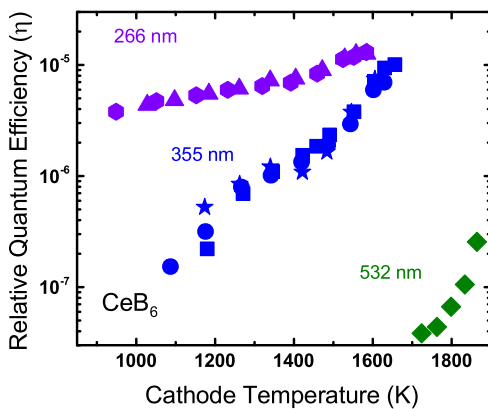

FIG. 10. Results of relative quantum efficiency measurement of CeB<sub>6</sub> cathode being irradiated at three different laser wavelengths, 266, 355 and 532 nm, measured by heating up the cathode.

and 355 nm irradiation wavelengths, minimal error is measured for higher photon energy.

The data for 532 nm excitation shows photoemission at a higher cathode temperature (1700–1900 K). This is caused by material degradation due to long operation times. In order to restore the emissivity to the previous level, the cathode temperature had to be increased. Nevertheless it was demonstrated that the photoemission below the work function can be recovered by increasing the cathode temperature even if material degradation has taken place.

The steep rise of the photocurrent seems to be correlated with the rise of the thermionic current. We suggest that the photoemission properties of a thermionic material and the TAPE effect can be predicted by its thermal emission properties. We would like to encourage interested researchers to further research this phenomenon.

#### D. Laser power dependence below work function

Electron extraction by laser photon energy below the work function can also be accomplished by two photon excitation processes. In Ref. [15] the authors have tried to perform electron extraction on LaB<sub>6</sub> below the work function. They had reported significant instability of emitted current and suggested a nonlinear process of photoemission. In order to exclude the second option, we have measured the laser pulse energy dependency.

Figure 11 displays the dependency of photoemission current of LaB<sub>6</sub> (a) and CeB<sub>6</sub> (b) on the incident laser pulse energy at 532 nm with the cathode temperature of around 1340 and 1800 K, respectively. The photon energy at this wavelength is lower than the work function. In this measurement, the integrated charge of the pulse had too small of a signal to noise ratio. Therefore, we measured the peak value of the current pulse and plotted it as the vertical axis of Fig. 11. The linear correlation of peak current with laser pulse energy is obvious. Thus in our setup the photoelectron extraction below the work function assisted by cathode heating occurs as a single photon absorption process.

#### E. Surface conditions

A hysteresis-like shape of QE dependence on cathode temperature was observed by the heating and cooling procedure. Figure 12 shows the recorded “hysteretic” behavior measured for LaB<sub>6</sub> for excitation at 266, 355 and 532. The data points were recorded in a short time interval of around 1–2 min. This tendency indicates changing surface conditions. By cooling down the photoemission current is higher than by heating up at the same cathode temperature. It can be understood as the removal of surface contamination during the heating up process. In particular, in Ref. [16], it was reported that below a critical temperature the cathode surface is covered by an oxide layer. This layer can be removed by heating above the

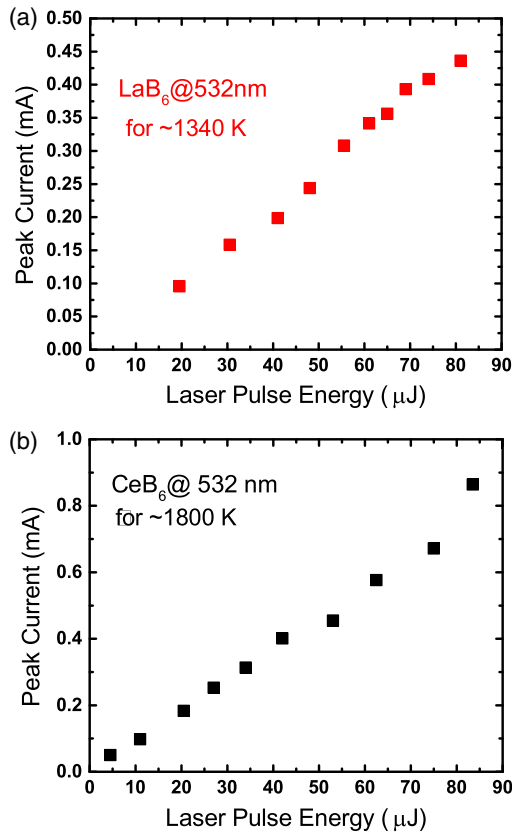

FIG. 11. Dependence of the peak photoemission current on laser pulse energy at 532 nm. (a)  $\text{LaB}_6$  for the cathode temperature of around 1340 K. (b)  $\text{CeB}_6$  for the cathode temperature of around 1800 K. For (a) and (b) the laser illuminated area was 1.72 mm in diameter.

critical temperature. Thereby the surface oxide reduces the QE.

Hysteretic behavior was also observed for  $\text{CeB}_6$  which is shown in Fig. 13. The hysteretic width has no regular structure and depends on operational duration. These

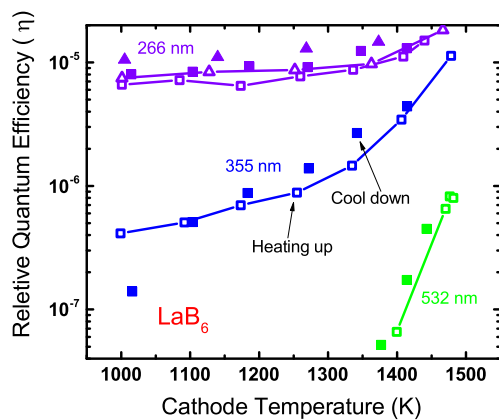

FIG. 12. Relative QE of  $\text{LaB}_6$  which is obtained with 266, 355 and 532 nm laser irradiation as the function of the cathode temperature during heating up and cooling down processes.

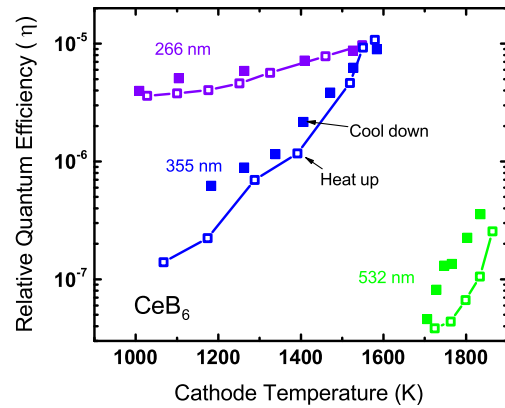

FIG. 13. Relative QE of  $\text{CeB}_6$  which is obtained with 266, 355 and 532 nm laser irradiation as the function of the cathode temperature during heating up and cooling down processes.

undesirable properties demonstrate the importance of proper cathode surface preparation.

The width of the “hysteresis” can be smaller at lower vacuum pressure ( $<10^{-8}$  Torr) conditions. As one can see in Figs. 12 and 13, the “hysteresis effect” is weaker than the TAPE effect.

#### IV. SUMMARY

In the present work, the thermally assisted photoemission (TAPE) effect of  $\text{LaB}_6$  and  $\text{CeB}_6$  cathodes was investigated by measuring their quantum efficiencies under various cathode temperature and excitation photon energy conditions. It was demonstrated that the quantum efficiency increases with cathode temperature along with thermionic emission. Meaning that the TAPE effect can enable us to obtain a higher quantum efficiency at a higher cathode temperature. The TAPE effect becomes more significant for lower excitation photon energy. Especially for excitation with photon energy below work function the TAPE is essential to achieve photoemission. The measurement of laser pulse energy dependence revealed that the excitation process under our experimental conditions was a single photon absorption.

Comparing the quantum efficiency of  $\text{LaB}_6$  and  $\text{CeB}_6$  cathodes,  $\text{LaB}_6$  had a higher quantum efficiency than that of  $\text{CeB}_6$  at the same temperature for all tested laser photon energies. This tendency corresponds to the thermal emission properties of these two materials. In general, the photocurrent was significantly higher than the thermionic current. However, for  $\text{CeB}_6$  at 532 nm the photocurrent was lower than the thermionic one.

During our measurements, a hysteresis of quantum efficiency dependence on the cathode temperature was observed. When the cathode temperature was cooled down from a higher temperature, the quantum efficiency was slightly higher than that measured during the heating up process. This behavior indicates a change of surface

conditions. In order to avoid this discrepancy a proper laser cleaning is required.

### ACKNOWLEDGMENTS

We would like to thank Dr. M. Bakr from the IAE, Kyoto University, for valuable help and comments.

- 
- [1] M. Asakawa, N. Sakamoto, Y. Shimizu, S. Nakai, K. Imasaki, and C. Yamanaka, Experimental studies of photocathode materials for FELs, *Nucl. Instrum. Methods Phys. Res., Sect. A* **331**, 302 (1993).
  - [2] S. Thorin *et al.*, Characterization of the beam from thermionic rf-gun adapted for photocathode operation, in *Proceedings of the 31st International Free Electron Laser Conference (FEL 09), Liverpool, UK* (STFC Daresbury Laboratory, Warrington, 2009).
  - [3] S. Giermann *et al.*, Operating a tungsten dispenser cathode in photoemission mode, in *Proceedings of the 23rd Particle Accelerator Conference, Vancouver, Canada, 2009* (IEEE, Piscataway, NJ, 2009).
  - [4] P. G. O'Shea, J. A. Lancaster, and R. Sachtshale, Radio frequency photoinjector using LaB<sub>6</sub> cathode and a nitrogen drive laser, *Appl. Phys. Lett.* **73**, 411 (1998).
  - [5] H. Zen *et al.*, Feasibility study of photocathode operation of thermionic rf gun at KU-FEL, in *Proceeding of the 7th International Particle Accelerator Conference, Busan, Korea* (2016), pp. 754–756.
  - [6] D. J. Bamford, M. H. Bakshi, and D. A. G. Deacon, The search for rugged, efficient photocathode materials, *Nucl. Instrum. Methods Phys. Res., Sect. A* **318**, 377 (1992).
  - [7] S. Mogren, and R. Reifenberger, Thermionic and threshold photoemission energy distributions from LaB<sub>6</sub> (110), *Surf. Sci.* **186**, 232 (1987).
  - [8] M. Boussoukaya, H. Bergeret, R. Chehab, and B. Leblond, Pulsed photocurrents from lanthanum hexaboride cathodes in the ns regime, *Nucl. Instrum. Methods Phys. Res., Sect. A* **264**, 131 (1988).
  - [9] A. Modinos, *Field, thermionic and secondary electron spectroscopy* (Plenum, New York, 1984).
  - [10] J. M. Lafferty, Boride cathodes, *J. Appl. Phys.* **22**, 299 (1951).
  - [11] M. Bakr *et al.*, Comparison between hexaboride materials for thermionic cathode rf gun, in *Proceedings of the 1st International Particle Accelerator Conference, Kyoto, Japan* (ICR, Kyoto, 2010), pp. 1782–1784.
  - [12] M. Bakr *et al.*, Comparison of the heating properties of LaB<sub>6</sub> and CeB<sub>6</sub> to the back bombardment effect in a thermionic rf gun, *J. Korean Phys. Soc.* **59**, 3273 (2011).
  - [13] <https://www.emsdiasum.com/microscopy/technical/datasheet/80920.aspx>.
  - [14] P. A. M. van der Heide, H. W. ten Cate, L. M. ten Dam, R. A. de Groot, and A. R. de Vroomen, Differences between LaB<sub>6</sub> and CeB<sub>6</sub> by means of spectroscopic ellipsometry, *J. Phys. F* **16**, 1617 (1986).
  - [15] B. Leblond, G. Kuznetsov, and M. Batazova, Short pulse photoemission from LaB<sub>6</sub>-based materials, *Nucl. Instrum. Methods Phys. Res., Sect. A* **372**, 562 (1996).
  - [16] M. Aono, R. Nishitani, C. Oshima, T. Tanaka, E. Bannai, and S. Kawai, Direct observation of LaB<sub>6</sub> (001) surface at high temperatures by x-ray and ultraviolet photoelectron spectroscopy, and work-function measurements, *J. Appl. Phys.* **50**, 4802 (1979).