

Ambiguous measurements, signaling, and violations of Leggett-Garg inequalities

Clive Emary

*Joint Quantum Centre Durham-Newcastle, School of Mathematics, Statistics and Physics, Newcastle University,
Newcastle upon Tyne NE1 7RU, England, United Kingdom*

(Received 21 June 2017; published 4 October 2017)

Ambiguous measurements do not reveal complete information about the system under test. Their quantum-mechanical counterparts are semiweak (or in the limit, weak) measurements and here we discuss their role in tests of the Leggett-Garg inequalities. We show that, while ambiguous measurements allow one to forgo the usual noninvasive measurability assumption, to derive a Leggett-Garg inequality that may be violated, we are forced to introduce another assumption that equates the invasive influence of ambiguous and unambiguous detectors. Based on this assumption, we derive signaling conditions that should be fulfilled for the plausibility of the Leggett-Garg test. We then propose an experiment on a three-level system with a direct quantum-optics realization that satisfies all signaling constraints and violates a Leggett-Garg inequality.

DOI: [10.1103/PhysRevA.96.042102](https://doi.org/10.1103/PhysRevA.96.042102)

I. INTRODUCTION

The Leggett-Garg inequalities (LGIs) [1] were constructed as tests of *macrorealism*, as defined by the following three assumptions (the first two as stated in Ref. [1]; the third was made explicit in, e.g., Refs. [2–4]).

A1. *Macroscopic realism per se*: A macroscopic system with two or more macroscopically distinct states available to it will at all times be in one or the other of these states.

A2. *Noninvasive measurability (NIM)*: It is possible, in principle, to determine the state of the system with arbitrarily small perturbation on its subsequent dynamics.

A3. *Arrow of time*: The outcome of a measurement on the system cannot be affected by what will or will not be measured on it later.

The inequalities that follow from these assumptions have been the subject of much work that was reviewed a few years ago in Ref. [5] with many theoretical [6–12] and experimental [13–21] developments having taken place since.

Of the three assumptions, assumption A2 is particularly vexatious since, while it assumes NIM to hold in principle, noninvasivity must also be seen to hold true in practice, otherwise any violation of an LGI can be assigned to some unwitting invasivity of the measurement [22]. This is the “clumsiness loophole” of Wilde and Mizel [23]. And, since quantum-mechanical measurements are in fact invasive, NIM is a counterfactual and can never be ruled out empirically.

Leggett and Garg’s proposal [1] for dealing with this situation was to use ideal negative measurements, and these have been employed in various recent experiments [13,19,21,24,25]. This approach, however, just shifts the locus of any presumed noninvasivity away from the system itself and onto some degree of freedom in its environment. There have been a number of attempts to formulate LGIs under different assumptions [26–30], but these too must ultimately suffer from similar loopholes.

This issue of invasivity relates to an important difference between the LGIs and the formally similar Bell’s inequalities, and this is the issue of *signaling* [4,9]. For spacelike separated observers Alice and Bob in a Bell test, we have the no-signaling

condition

$$P(A) - \sum_B P(A, B) = 0, \quad (1)$$

where $P(A)$ is the probability that Alice obtains result A and $P(A, B)$ is the joint probability of result A for Alice and B for Bob. Thus, the influence of Bob’s measurement is statistically undetectable to Alice (and vice versa). In the LGI setting, there is no external physical principle such as locality to which we can appeal that enforces a lack of signaling between the two measurements. Let us define

$$\delta(n_3) = P(n_3) - \sum_{n_2} P(n_3, n_2), \quad (2)$$

where n_2 and n_3 are outcomes of measurements at times t_2 and $t_3 > t_2$, to quantify the signaling in an LGI context. Under assumptions A1–A3, these signaling quantifiers should be zero, just as in Bell’s test. Indeed the *no-signaling-in-time* (NSIT) equalities $\delta(n_3) = 0$ [4], or ones very similar to them [31], have been discussed as tests of macrorealism themselves [4,7,12,32]. These studies show that, generically, quantum-mechanical violations of an LGI are accompanied by a violation of NSIT conditions (see Ref. [33] and also Sec. II). From this, a macrorealist would conclude that, since there is experimental evidence that the measurements can signal forward in time, they are invasive and assumption A2 does not hold in practice. Thus, observation that the NSIT equalities hold may be taken as a necessary (but by no means sufficient) condition that our measurements appear noninvasive. NSIT also restores the symmetry between LGIs and Bell inequalities.

A number of ways of achieving LGI violations without signaling have been discussed. Much has been written about weak (or semiweak) measurements [34,35] and the violation of the LGIs [36–43]. As Halliwell makes clear [9], weakly measured quasiprobabilities naturally have the NSIT property and can violate LGI inequalities. The importance of weak measurements in unifying spatial and temporal correlations, and hence LG and Bell inequalities, has been discussed in, e.g., Ref. [44]. Outside the weak-measurement paradigm, the work of George *et al.* [33] (see also Ref. [45]) stands out as having reported a measurement of an LGI violation while obeying the relevant no-signaling conditions (George *et al.*

used the language of the measurements being “nondisturbing” rather than no-signaling). These results, however, came in a very specific setting, viz., the quantum three-box paradox, leaving open the question as to whether their results represent a peculiarity of this model, or whether similar situations can be found in other, perhaps even macroscopic, systems.

In this paper we describe a general approach to LGI violations using a set of ambiguous measurements [46] that are realized quantum mechanically by a particular class of positive operator-valued measure (POVM). We show that with the quasiprobabilities inferred from such measurements we are able to violate an LGI inequality without making the NIM assumption. However, in order to justify use of these quasiprobabilities as proxies for the real thing, we find we must make an alternative assumption that equates the invasive influence of ambiguous and unambiguous detectors on a macroreal state. We will call this assumption *equivalently invasive measurability* (EIM). We believe that an assumption along these lines tacitly underlies previous work on weak measurements and the LGI. While it may seem hard to justify *a priori* that two potentially very different detectors are invasive in the same way (although, see later), this assumption leads to a testable consequence, namely, that the signaling quantifiers for both detectors should be equal. These conditions we call *equal signaling in time* (ESIT) and they can be tested empirically. We note here that the assumption of EIM in the presence of fulfilled NSIT conditions is similar to the noncollusion of adroit measurements discussed by Wilde and Mizel [23].

From our considerations we arrive at several conclusions.

(i) Violations of any single LGI are always accompanied by violations of NSIT (this is a slight generalization of a result given in Ref. [33]).

(ii) There exist specific combinations of quantum dynamics and ambiguous measurements that can both violate LGIs and satisfy ESIT. In the examples we discuss here, ESIT is realized through the NSIT conditions for both ambiguous and unambiguous measurements, each being exactly zero. We thus show that the results of George *et al.* [33] can be generalized to arbitrary systems, provided we choose the dynamics and measurements appropriately.

(iii) In general, violations of LGIs in the weak-measurement limit are accompanied by a violation of ESIT (and would thus be unconvincing to a macrorealist). This must always be the case when our measurements involve just two outcomes. However, we also show that there exist specific weak-measurement scenarios with multiple outcomes in which ESIT remains intact.

This paper proceeds as follows. In Sec. II we derive a modified version of the LGI without making the NIM assumption and show that directly measured probabilities, even those from quantum mechanics, can never violate it. In Sec. III we then introduce our ambiguous measurements, discuss the necessity of the EIM assumption, and construct our ambiguously measured LGI. We then analyze this quantum mechanically in Sec. IV and show how the ambiguous LGI can be violated while ESIT is preserved in general. In Sec. V we discuss a concrete example of our formalism, eminently realizable in terms of the quantum optics setup pursued in Refs. [19,20]. In Sec. VI we make the connection with weak

measurements, before discussing the significance of our results in Sec. VII.

II. THE LGI WITHOUT THE NONINVASIVE MEASURABILITY ASSUMPTION

The most-studied LG correlator involves dichotomic observable $Q = \pm 1$ and reads

$$K \equiv \langle Q_2 Q_1 \rangle + \langle Q_3 Q_2 \rangle - \langle Q_3 Q_1 \rangle, \quad (3)$$

where $Q_i = Q(t_i)$ is the measurement outcome at times $t_3 > t_2 > t_1$. Under assumptions A1–A3, Leggett and Garg showed that $K \leq 1$. We want to investigate this correlator without assumption A2. To simplify matters, we first assume the coincidence of the measurement at t_1 and our preparation step [11,13,19,40]. Declaring $Q_1 = +1$, the LG correlator becomes

$$K = \langle Q_2 \rangle + \langle Q_3 Q_2 \rangle - \langle Q_3 \rangle. \quad (4)$$

We assume that our measurements unambiguously reveal one of M different outcomes, each of which we associate with a different “macroscopically distinct” state. We allot a Q value to each via $q(n) = \pm 1$ with $1 \leq n \leq M$ [47]. In terms of the probabilities $P(n_i)$ of obtaining result n_i at time t_i , the simple expectation values in K read $\langle Q_i \rangle = \sum_{n_i} q(n_i)P(n_i)$. Under assumptions A1 and A3 (but not A2), adding a measurement at time t_3 does not affect the result at t_2 and so we can write $\langle Q_2 \rangle = \sum_{n_3, n_2} q(n_2)P(n_3, n_2)$, where $P(n_3, n_2)$ is the joint probability of measuring n_2 and n_3 . We then use the signaling quantifiers $\delta(n_3)$ in Eq. (2) to eliminate $P(n_3)$ from K . The result is

$$K = \sum_{n_3, n_2} [q(n_2) + q(n_2)q(n_3) - q(n_3)]P(n_3, n_2) - \sum_{n_3} q(n_3)\delta(n_3). \quad (5)$$

The first term here is what we get under the standard derivation of the LGI with NIM. The second term is new and describes the effects of the invasiveness of our measurements. Taking a maximally adverse position, independent maximization of these two terms yields our modified NIM-free LGI [48]:

$$K \leq 1 + \Delta \quad \text{with} \quad \Delta \equiv \sum_{n_3} |\delta(n_3)|. \quad (6)$$

The idea is, therefore, to make measurements of both K and Δ and compare them with this inequality. It is immediately clear, however, that as long as $P(n_3, n_2)$ and $P_3(n_3)$ form two sets of genuine probabilities, then Eq. (6) can never be violated. This holds just as well for probabilities obtained quantum mechanically, and is indeed irrespective of whether the measurements are projective or more general.

III. AMBIGUOUS MEASUREMENTS

The foregoing makes clear that we are never going to violate Eq. (6) with directly measured probabilities. The only remaining possibility is therefore to replace the measured probabilities with *quasiprobabilities* in a way that a macrorealist would feel was a fair substitution. We maintain that this

can only be the case when we perform two experiments and compare them. The first experiment proceeds as above with our detector at time t_2 giving unambiguously one of $1 \leq n \leq M$ outcomes. These results are repeatable. The second experiment analyzes the same system, but with the detector at time t_2 being ambiguous [46]. This detector gives one of $1 \leq \alpha \leq M_A$ results with the key property that repeated measurements do not necessarily lead to the same outcome. The macrorealist will view this measurement as only revealing incomplete information about the “real state” of the system.

We then look to relate the two experiments. By following a measurement of unambiguous result n with an ambiguous measurement, we obtain the conditional probabilities $c_{\alpha n}$ that state n gives response α . Using these results and Bayes’s rule, the macrorealist would be happy to write the probability of obtaining result α as

$$P(\alpha) = \sum_n c_{\alpha n} \mathcal{P}(n). \quad (7)$$

We use the notation \mathcal{P} to denote a probability that is not measured directly but rather inferred. Collecting coefficients $c_{\alpha n}$ into matrix \mathbf{c} and assuming $M_A \geq M$ such that the ambiguous measurements give us sufficient information to reconstruct $\mathcal{P}(n)$, we write

$$\mathcal{P}(n) = \sum_\alpha d_{n\alpha} P(\alpha), \quad (8)$$

where $d_{n\alpha}$ are elements of the left inverse of \mathbf{c} , i.e., $\mathbf{d} \cdot \mathbf{c} = \mathbb{1}$. Note that we cannot measure the quantities $d_{n\alpha}$ directly, as we do not know what it means to prepare in “state α .”

In analogy with Eq. (8), we next write down the inferred joint probability:

$$P(n_3, n_2) = \sum_\alpha d_{n_2 \alpha} P(n_3, \alpha). \quad (9)$$

For a macrorealist to agree that this inferred probability is the same as the directly measured one, $P(n_3, n_2)$, he or she would have to assume that the evolution of the system from state n_2 is the same with the ambiguous detector in place as it would be had we actually measured result n_2 with the unambiguous detector. We codify this assumption, which we make here as an alternative to NIM, as follows:

A2*. *Equivalently invasive measurability (EIM)*: The invasive influence of ambiguous measurements on any given macroreal state is the same as that of unambiguous ones.

The degree of signaling due to the ambiguous measurements is quantified by

$$\delta_A(n_3) \equiv P(n_3) - \sum_\alpha P(n_3, \alpha). \quad (10)$$

Inserting $\sum_n d_{n\alpha} = 1$ from the conservation of probability and using Eq. (9), we obtain

$$\delta_A(n_3) = P(n_3) - \sum_{n_2} \mathcal{P}(n_3, n_2). \quad (11)$$

Thus, as a consequence of assumption A2*, the macrorealist will expect the signaling quantifiers $\delta(n_3)$ and $\delta_A(n_3)$ to be the same. Let us quantify this by defining the “signaling

differences”

$$D(n_3) \equiv \delta(n_3) - \delta_A(n_3), \quad (12)$$

which, under EIM, obey

$$D(n_3) = 0; \forall n_3. \quad (13)$$

In analogy with no-signaling in time, we dub these conditions the equal-signaling-in-time equalities.

To obtain an LGI that may be violated, we take Eq. (5) and replace the measured probabilities with the inferred ones, Eq. (9). This yields the correlator

$$K_A = \sum_{n_3, n_2, \alpha} [q(n_2) + q(n_2)q(n_3) - q(n_3)] d_{n_2 \alpha} P(n_3, \alpha) - \sum_{n_3} q(n_3) \delta_A(n_3), \quad (14)$$

which involves measured quantities only. Perceiving this correlator to be equivalent to Eq. (5), the macrorealist would expect K_A and $\delta_A(n_3)$ to be related in the same way as the original K and $\delta(n_3)$. Thus we obtain

$$K_A \leq 1 + \Delta_A, \quad \Delta_A = \sum_{n_3} |\delta_A(n_3)|. \quad (15)$$

This we will refer to as the ambiguously measured LGI. The important point is that the macrorealist would only write down this inequality down if they were convinced first of the existence of the states n (for which we need the unambiguous measurements), and second that assumption A2* is valid.

IV. QUANTUM FORMULATION

We now describe the situation quantum mechanically. Let ρ_i be the system density matrix at time t_i , and let the time evolution from time t_i to t_j be given by $\rho_j = \Omega_{ji}[\rho_i] = U_{ji} \rho U_{ji}^\dagger$ with U_{ji} the appropriate unitary operator. Our unambiguous measurement is described with orthogonal projectors Π_n , $1 \leq n \leq M$ that obey $\sum_n \Pi_n = \mathbb{1}$ and $\Pi_n \Pi_{n'} = \delta_{nn'} \Pi_n$, thus ensuring the repeatability of the measurement. In this case the signaling quantifiers are given by

$$\delta^{\text{QM}}(n_3) = \sum_{n, n' \neq n} X(n_3, n, n'), \quad (16)$$

with $X(n_3, n, n') \equiv \text{Tr}\{\Pi_{n_3} \Omega_{32}[\Pi_n \rho_2 \Pi_{n'}]\}$.

In the ambiguous case, the measurement is described by a POVM with elements that we take to be sums of projection operators

$$F_\alpha = \sum_{n_2} c_{\alpha n_2} \Pi_{n_2}, \quad (17)$$

and have a clear interpretation in terms of the states n . With $P(\alpha) = \text{Tr}\{F_\alpha \rho_2\}$ and $P(n) = \text{Tr}\{\Pi_n \rho\}$, this immediately reproduces Eq. (7). The POVM elements are associated with the Kraus operators as $F_\alpha = M_\alpha^2$ with $M_\alpha = M_\alpha^\dagger = \sum_n \sqrt{c_{\alpha n}} \Pi_n$, such that the joint probabilities are given by $P(n_3, \alpha) = \text{Tr}\{\Pi_{n_3} \Omega_{32}[M_\alpha \rho_2 M_\alpha]\}$. This gives the ambiguous signaling quantifiers as

$$\delta_A^{\text{QM}}(n_3) = \sum_{n, n' \neq n} \gamma(n, n') X(n_3, n, n') \quad (18)$$

with $\gamma(n, n') = 1 - \sum_{\alpha} \sqrt{c_{\alpha n} c_{\alpha n'}}$. Similarly, from Eq. (14), the LG correlator is

$$\begin{aligned} K_A^{\text{QM}} &= \sum_{n_3 n_2} [q(n_2) + q(n_2)q(n_3) - q(n_3)]P(n_3, n_2) \\ &\quad - \sum_{n_3} q(n_3)\delta_A^{\text{QM}}(n_3) \\ &\quad + \sum_{n_2, n_3} [q(n_2) + q(n_2)q(n_3) - q(n_3)]\kappa(n_3, n_2), \end{aligned}$$

with

$$\kappa(n_2, n_3) \equiv \sum_{n, n' \neq n} \Gamma(n_2, n, n')X(n_3, n, n'), \quad (19)$$

and $\Gamma(n_2, n, n') \equiv \sum_{\alpha} d_{n_2 \alpha} \sqrt{c_{\alpha n} c_{\alpha n'}}$. The important result here is that, whereas the first two terms in K_A^{QM} are exactly what we get in the unambiguous case [see Eq. (5)], a third term appears which is not directly related to the signaling quantifiers. This new term opens up the possibility of violating Eq. (15).

If we look at the signaling difference, however, we find that

$$D^{\text{QM}}(n_3) = \sum_{n, n' \neq n} [1 - \gamma(n, n')]X(n_3, n, n'). \quad (20)$$

Unless we can set these quantities to zero, the macrorealist can conclude that assumption A2* does not hold, and any violation of the ambiguously measured LGI is due to the noncomparability of the two experiments.

V. INVERTED MEASUREMENTS AND A QUANTUM-OPTICS REALIZATION

Is it possible to satisfy ESIT $D(n_3) = 0; \forall n_3$ and still violate Eq. (15)? We answer this question by considering a simple measurement scheme which we call an ‘‘inverted measurement.’’ The idea is that, whereas the unambiguous detector identifies the system as being in state n , the inverted-measurement detector identifies it as being in any state other than n . So, with three unambiguous outcomes $n \in \{A, B, C\}$, our inverted measurement detects the three disjunctions: $A \cup B$, $B \cup C$, and $A \cup C$. From these, a macrorealist would have no qualms inferring the (quasi)probabilities $\mathcal{P}(A) = P(A \cup B) + P(A \cup C) - P(B \cup C)$, etc. Such a detector has $M_A = M$ and is described by the matrices

$$\mathbf{c} = \frac{1}{M-1}(\mathbb{J} - \mathbb{1}), \quad \mathbf{d} = \mathbb{J} - (M-1)\mathbb{1}, \quad (21)$$

where $\mathbb{1}$ is the unit matrix and \mathbb{J} is a matrix of ones.

With this detector, we obtain $(M-1)\delta_A^{\text{QM}}(n_3) = \delta^{\text{QM}}(n_3)$, with $\delta^{\text{QM}}(n_3)$ as in Eq. (16), and thus

$$D^{\text{QM}}(n_3) = (M-2)\delta_A(n_3). \quad (22)$$

Thus, if we can find a quantum dynamics that obeys NSIT, then ESIT will be automatically satisfied. Furthermore, with this measurement setup, the terms responsible for LGI violations read

$$\kappa(n_3, n_2) = -\delta_A^{\text{QM}}(n_3) + \sum_n [X(n_3, n_2, n) + X(n_3, n, n_2)], \quad (23)$$

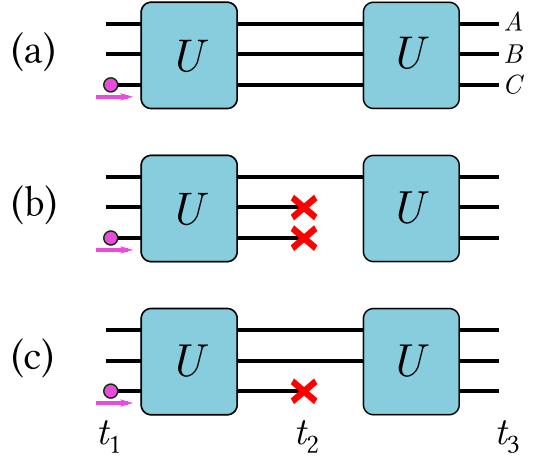

FIG. 1. Sketch of a three-level system realized as optical channels A , B , and C with nontrivial time evolution generated by the blocks labeled U . We initialize by injecting a photon into channel C . Three configurations are shown. (a) No measurement at t_2 . (b) Unambiguous measurement. With blocking elements in channels B and C , detection of the photon at t_3 means that we can infer that the photon was in channel A at time t_2 . (c) Ambiguous measurement. With only channel C blocked, detection of the photon at t_3 means that, from a macrorealistic point of view, the photon was in either channel A or B at time t_2 .

which remain finite even when $\delta_A^{\text{QM}}(n_3) = 0$. Thus this scheme offers a route to satisfy NSIT for both measurements, ESIT along with it, and still violate Eq. (15).

We now consider a three-level system as the lowest-dimensional system for which inverse measurements make sense. We label the states $n \in \{A, B, C\}$, choose measurement assignments $q(A) = -q(B) = q(C) = 1$, and initialize the system in state $\rho_1 = |C\rangle\langle C|$. Time evolution is governed by $U_{21} = U_{32} = U$ with

$$\begin{aligned} U &= \begin{pmatrix} 1 & 0 & 0 \\ 0 & \cos \phi & \sin \phi \\ 0 & -\sin \phi & \cos \phi \end{pmatrix} \times \begin{pmatrix} \cos \chi & 0 & \sin \chi \\ 0 & 1 & 0 \\ -\sin \chi & 0 & \cos \chi \end{pmatrix} \\ &\quad \times \begin{pmatrix} \cos \theta & \sin \theta & 0 \\ -\sin \theta & \cos \theta & 0 \\ 0 & 0 & 1 \end{pmatrix}, \quad (24) \end{aligned}$$

with parameters ϕ , χ , and θ .

A setup like this was realized optically in Refs. [19,20], and our inverted-measurement scheme would have a particularly straightforward implementation in this context (see Fig. 1). The system state is encoded in one of three optical channels. Measurements are made through a combination of photon detectors on the far right (t_3) and by placing a sequence of blocking elements in the optical paths at t_2 . Projective measurements of the probabilities $P(n_3, A)$ are unambiguously obtained by blocking two paths at once [Fig. 1(b)] since if we block, e.g., paths B and C the photon must have passed through channel A at t_2 to survive through to the detector. In contrast, our inverted measurements are obtained by blocking just one of the three channels [Fig. 1(c)]. With a block in channel C , say, a detection of a photon at t_3 would lead a macrorealist

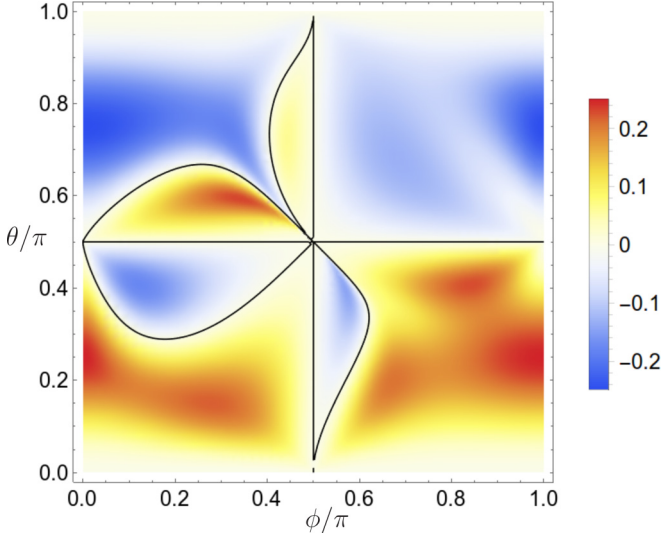

FIG. 2. The signaling quantifier $\delta_A^{\text{QM}}(B)$ as a function of parameters θ and ϕ for ambiguous measurements of a three-level system. Parameter χ was chosen to set $\delta_A^{\text{QM}}(A) = 0$. The black lines indicate parameters for which $\delta_A^{\text{QM}}(B) = -\delta_A^{\text{QM}}(C) = 0$ and both NSIT and ESIT are obeyed.

to infer that the photon state must have been either A or B at time t_2 .

We then calculate δ_A^{QM} for this system and choose χ as a function of ϕ and θ such that $\delta_A^{\text{QM}}(A) = 0$. Since $\sum_{n_3} \delta_A^{\text{QM}}(n_3) = 0$, we have $\delta_A^{\text{QM}}(B) = -\delta_A^{\text{QM}}(C)$ such that when one of these two remaining NSIT indicators is set to zero then all three are zero. Figure 2 shows $\delta_A^{\text{QM}}(B)$ as a function of the two angles θ and ϕ . Marked in black are the parameters for which $\delta_A^{\text{QM}}(B) = 0$. Figure 3 shows the corresponding LGI correlator K_A^{QM} , which takes values up to a maximum of $K_A^{\text{QM}} = 1.9$. Overlaid on this figure are the no-signaling lines from Fig. 2. In many places, these lines coincide with the LG correlator taking the value $K_A^{\text{QM}} = 1$. However, there are also several regions where this is not the case, and in particular in the top left corner of this figure we see a no-signaling line intersect a region with $K_A^{\text{QM}} > 1$. For these parameter values, then, we have NSIT, ESIT, and a violation of the LGI.

Figure 4 shows two cuts through Fig. 3. Figure 4(a) reveals the maximum value of K_A^{QM} when signaling is zero to be $K_A^{\text{QM}} = 1.464$. Figure 4(b) shows a straight cut through Fig. 3 for fixed θ . On this plot we also show the quantity $1 + \Delta_A^{\text{QM}}$, which represents the modified upper bound for K_A^{QM} . Only around the points where Δ_A^{QM} is close to zero do we obtain LGI violations.

VI. WEAK MEASUREMENTS

As an example of LGI violations with weak measurements, let us consider a detector ($M_A = M$) described by

$$\mathbf{c} = \frac{1-\epsilon}{M} \mathbb{J} + \epsilon \mathbb{1}, \quad \mathbf{d} = \frac{1}{\epsilon} \mathbb{1} + \frac{\epsilon-1}{\epsilon M} \mathbb{J}. \quad (25)$$

Each detector response is biased towards a certain (unambiguous) outcome, but in the limit $\epsilon \rightarrow 0$ this bias disappears

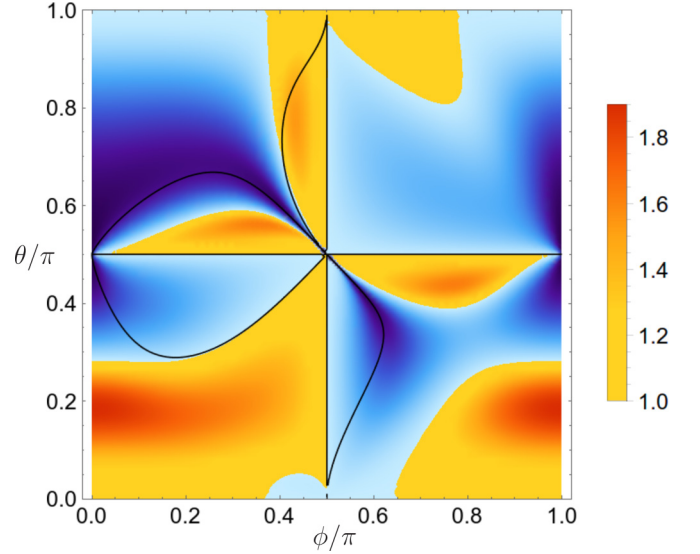

FIG. 3. The ambiguously measured LG correlator K_A^{QM} for our three-level system as a function of angles θ and ϕ . Red and orange colors correspond to $K_A^{\text{QM}} > 1$; blue corresponds to $K_A^{\text{QM}} < 1$. The black lines are the no-signaling lines from Fig. 2 along which $\delta_A^{\text{QM}}(n_3) = 0; \forall n_3$. In the top-left quadrant we see the no-signaling line intersect a $K > 1$ region, such that we have NSIT, ESIT, and a violation of the LGI.

and the measurement becomes weak. To leading order in ϵ , we obtain $\gamma(n, n') \approx \frac{M}{4} \epsilon^2$ and $\Gamma(n_2, n, n') \approx \frac{1}{2} (\delta_{n, n_2} + \delta_{n', n_2})$. Thus, with this detector in the $\epsilon \rightarrow 0$ limit, the ambiguous NSIT quantities become

$$\lim_{\epsilon \rightarrow 0} \delta_A^{\text{QM}}(n_3) = 0, \quad (26)$$

and there is no signaling for the weak measurement. Meanwhile, for terms responsible for violation of the ambiguous LGI, we obtain

$$\lim_{\epsilon \rightarrow 0} \kappa(n_2, n_3) = \frac{1}{2} \sum_{n \neq n_2} [X(n_3, n_2, n) + X(n_3, n, n_2)],$$

which will be nonzero provided there are coherences between basis states at time t_2 . Indeed, with these results we can rewrite the LG correlator as

$$\lim_{\epsilon \rightarrow 0} K_A^{\text{QM}} = \text{Tr} \left\{ [\hat{Q}_2 + \frac{1}{2} \{\hat{Q}_2, \hat{Q}_3\} - \hat{Q}_3] \rho_1 \right\} \quad (27)$$

where $\hat{Q}_n = \hat{Q}(t_n) = U_{n1}^\dagger (\sum_m q(m) \Pi_m) U_{n1}$ is the measured operator in the Heisenberg picture at time t_n and $\{\cdot, \cdot\}$ denotes the anticommutator. We thus arrive at the weakly measured form of the LGI as discussed in, e.g., Ref. [9]. From Fritz [49], we know that the maximum quantum-mechanical value of this quantity is identical to that obtained in the projective case in the Lüders limit [47,50], i.e., when the number of projectors is exactly 2. Thus, we conclude that, in the weak-measurement case,

$$\lim_{\epsilon \rightarrow 0} K_A^{\text{QM}} \leq 1 + \Delta_{\text{Lüders}}^{\text{QM}} \leq \frac{3}{2}, \quad (28)$$

where $\Delta_{\text{Lüders}}^{\text{QM}}$ is the no-signaling quantity that would be obtained under a projective Lüders measurement. Since this

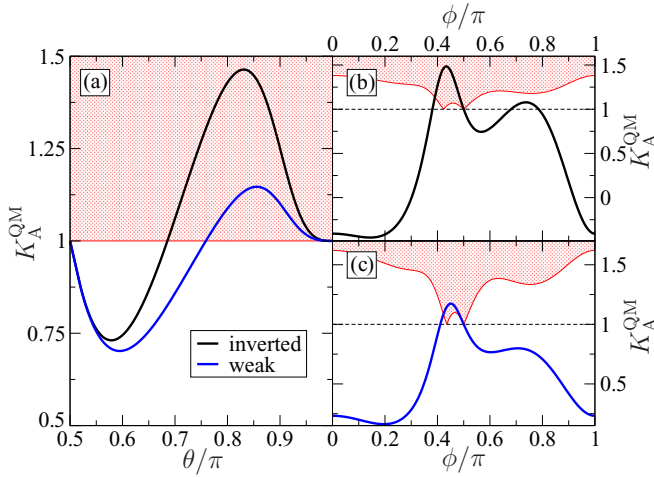

FIG. 4. Two cuts through Fig. 3 for the inverted-measurement case plus corresponding results for the weak measurements of Sec. VI. (a) The correlator K_A^{QM} as a function of θ along the no-signaling line that goes through the orange region in Fig. 3. Since $\Delta_A = 0$ along this line, the LGI reverts to $K_A \leq 1$ and violations of Eq. (15) occur within the indicated red region. Black line, inverted measurement; blue line, weak measurement. (b) The correlator K_A^{QM} along the straight-line cut in Fig. 3 from $\phi = 0$ to π with $\theta = 0.831\pi$. The red region shows the right-hand side of Eq. (15) and, since generally we have signaling here, this quantity is greater than 1. Indeed, only near the maximum of K_A^{QM} does $1 + \Delta_A^{\text{QM}}$ drop significantly such that we obtain a violation of Eq. (15). N.B.: The maximum of the K_A^{QM} curve here is slightly displaced from the no-signaling point and thus has a value slightly higher than the no-signaling maximum (1.482 vs 1.464). (c) The same as panel (b) but for the weakly measured case with $\theta = 0.856\pi$. Again the maximum is slightly offset from the no-signaling maximum (1.173 vs 1.147).

will generally be nonzero, no-signaling violations of the weakly measured LGI are possible.

This, however, indicates a problem when the number of outcomes for our unambiguous measurements is actually $M = 2$, because then the quantity $\Delta_{\text{Lüders}}^{\text{QM}}$ in Eq. (28) is exactly the same Δ^{QM} for the unambiguous measurements. Thus violations of the ambiguously measured LGI imply violations of the unambiguous NSIT equalities. In the $M = 2$ case, therefore, we have $\lim_{\epsilon \rightarrow 0} D^{\text{QM}}(n_3) = \delta^{\text{QM}}(n_3) \neq 0$ for at least some n_3 , from which the realist would conclude that assumption A2* is invalid.

Away from this $M = 2$ case, however, this argument does not apply, and we may obtain $\Delta^{\text{QM}} = 0$ while $\Delta_{\text{Lüders}}^{\text{QM}} > 0$, since they are different quantities. To show that this is the case, we return to the three-level system of the last section for which $M = 3$. For this model, we already know that $\Delta^{\text{QM}} = \Delta_A^{\text{QM}} = 0$ along the lines shown in Fig. 2. A plot of the weakly measured LG correlator of Eq. (27) (not shown) then looks very similar to Fig. 3 (but with less-pronounced maxima) and again shows a region of LGI violation intersected by the no-signaling line. Figure 4(a) shows the value of K_A^{QM} along this line, from which we obtain a maximum violation of $K_A^{\text{QM}} = 1.147$ (and thus $\Delta_{\text{Lüders}}^{\text{QM}} = 0.147$). Figure 4(c) also shows a cut for fixed θ through the maximum.

VII. DISCUSSION

In Sec. II we saw that in attempting to derive an LGI without the NIM assumption A2 we ensure that it can never be violated. This is not surprising because a realistic description of nature by itself is not inconsistent with the probabilities of quantum mechanics [2]. To obtain an inequality that we could violate, we considered two measurements, one unambiguous and one ambiguous [51]. By comparing the two, and replacing a probability in an inequality derived for one experiment with a (quasi)probability inferred from the other, we obtained our “ambiguously measured LGI” which, as we have seen in our examples, can be violated by quantum theory. To justify this switch, however, we had to introduce the EIM assumption A2*, in which the invasivity of the measurements in each of the two experiments was taken to be equivalent. Making the role of this assumption explicit in LGI tests with ambiguous or weak measurements is one of the main results of this paper.

While the EIM assumption may not seem particularly plausible in the abstract [52], for certain detectors, it might be. In particular, consider measurements that are realized with a set of individual detectors, each of which only interacts with the system when it is in just one of the macroreal states (as in ideal negative measurements). In this case, then, the unambiguous measurement would be implemented by using one of these detectors at a time, whereas the ambiguous measurement would involve using more than one, deployed in such a way that any knowledge of which particular detector had fired was lost. Since in this case the components of the ambiguous measurement are “just the sum” of those from the unambiguous one, one could reasonably expect the influence on the system of the two measurements to be the same. But, more than consideration of any specific realization, just as NIM leads to the NSIT conditions, so the EIM assumption leads to the ESIT conditions, and these can be experimentally tested.

And while successful NSIT and ESIT tests can not exclude NIM and EIM, respectively, they would at least provide the macrorealist with some level of empirical confidence that the experiment was functioning in conformity with these principles.

In this paper we have discussed the concrete example of a three-level system, under both inverted and weak measurements, and found parameter regimes where it can satisfy both NSIT and ESIT equalities while violating an LGI. In the weak measurement case, it is important to note that while the NSIT equality is guaranteed to hold for the weak measurement itself this is not necessarily the case for the unambiguous part of the experiment and thus, generally, ESIT would not hold in these experiments. Only under certain model-specific circumstances, and only when the system dimension is greater than 2, can both NSIT and ESIT be fulfilled. As we show in the Appendix, the three-box problem from the experiment of George *et al.* [33] can be understood within the framework discussed here and shows the required NSIT and ESIT properties.

Faced, then, with the violation of an ambiguously measured LGI, together with the satisfaction of ESIT, what would a macrorealist conclude? Certainly, this would give more cause for thought than having measured an LGI violation in a single experiment, as there a measurement of the NSIT

equalities would be enough to dismiss the measurements as signaling. With the ambiguous prescription and ESIT, the macrorealist would be faced with either giving up the combination of assumptions A1 and A3 or finding an explanation for how two different measurements can somehow conspire to give exactly the same degree of signaling and yet somehow influence the system in very different ways. This problem is compounded in the case where ESIT is satisfied through NSIT being satisfied for both experiments, as in this case both experiments are individually nonsignaling. With this, then, we arrive at a situation similar to that presented by Wilde and Mizel [23] (with a recent realization [18]). While the measurement procedures in their work were very different from those considered here (involving different bases), the problem created for the macrorealist is similar—in order to maintain a macrorealistic description of the system, the macrorealist is left with having to explain away a collusion between two sets of measurements. When properly executed, then, ambiguously measured LGIs provide a further way with which we might narrow the “clumsiness loophole.”

ACKNOWLEDGMENT

We are grateful to G. Knee, J. Halliwell, K. Wang, and P. Xue for helpful discussions.

APPENDIX: QUANTUM THREE-BOX PROBLEM

The quantum three-box problem [33,45] can be cast in the language used here. With the three states labeled as in

Sec. V Alice’s measurement at time t_3 is characterized by two projectors $\Pi_{-1}^{(3)} = |C\rangle\langle C|$ and $\Pi_{+1}^{(3)} = \mathbb{1} - |C\rangle\langle C|$, which we have labeled with the respective $q = \pm 1$ assignments and a superscript to distinguish them from the previous projectors. Bob’s measurement at time t_2 can be characterized by a four-element POVM with

$$\mathbf{c} = \frac{1}{2} \begin{pmatrix} 1 & 0 & 0 \\ 0 & 1 & 1 \\ 0 & 1 & 0 \\ 1 & 0 & 1 \end{pmatrix}, \tag{A1}$$

and the assignments $q(A) = q(B) = -q(C) = +1$. For the time evolution operators we take

$$U_{21} = \frac{1}{\sqrt{6}} \begin{pmatrix} 2 & 0 & \sqrt{2} \\ -1 & \sqrt{3} & \sqrt{2} \\ -1 & -\sqrt{3} & \sqrt{2} \end{pmatrix}, \tag{A2}$$

$$U_{32} = \frac{1}{\sqrt{6}} \begin{pmatrix} 1 & 1 & 2 \\ \sqrt{3} & -\sqrt{3} & 0 \\ \sqrt{2} & \sqrt{2} & -\sqrt{2} \end{pmatrix}. \tag{A3}$$

Finally, we need to consider a different, but essentially equivalent [5], version of the LGI:

$$K' = \langle Q_2 \rangle_{21} + \langle Q_3 Q_2 \rangle_{321} - \langle Q_3 \rangle_{31} \geq -1. \tag{A4}$$

Calculating with the above formalism gives $\delta_A^{\text{QM}}(n_3) = \delta^{\text{QM}}(n_3) = 0$ such that Bob’s measurements are nonsignaling and ESIT is satisfied, along with $K'_A{}^{\text{QM}} = -13/9$, such that the ambiguous LGI is violated. This is in agreement with Ref. [33].

[1] A. J. Leggett and A. Garg, *Phys. Rev. Lett.* **54**, 857 (1985).
 [2] A. J. Leggett, *Rep. Prog. Phys.* **71**, 022001 (2008).
 [3] J. Kofler and Č. Brukner, *Phys. Rev. Lett.* **101**, 090403 (2008).
 [4] J. Kofler and Č. Brukner, *Phys. Rev. A* **87**, 052115 (2013).
 [5] C. Emary, N. Lambert, and F. Nori, *Rep. Prog. Phys.* **77**, 016001 (2014).
 [6] A. Asadian, C. Brukner, and P. Rabl, *Phys. Rev. Lett.* **112**, 190402 (2014).
 [7] G. Schild and C. Emary, *Phys. Rev. A* **92**, 032101 (2015).
 [8] S. Brierley, A. Kosowski, M. Markiewicz, T. Paterek, and A. Przysiężna, *Phys. Rev. Lett.* **115**, 120404 (2015).
 [9] J. J. Halliwell, *Phys. Rev. A* **93**, 022123 (2016).
 [10] J. J. Halliwell, *Phys. Rev. A* **94**, 052131 (2016).
 [11] N. Lambert, K. Debnath, A. F. Kockum, G. C. Knee, W. J. Munro, and F. Nori, *Phys. Rev. A* **94**, 012105 (2016).
 [12] L. Clemente and J. Kofler, *Phys. Rev. Lett.* **116**, 150401 (2016).
 [13] C. Robens, W. Alt, D. Meschede, C. Emary, and A. Alberti, *Phys. Rev. X* **5**, 011003 (2015).
 [14] Z.-Q. Zhou, S. F. Huelga, C.-F. Li, and G.-C. Guo, *Phys. Rev. Lett.* **115**, 113002 (2015).
 [15] C. Robens, W. Alt, C. Emary, D. Meschede, and A. Alberti, *Appl. Phys. B* **123**, 12 (2016).
 [16] G. C. Knee, K. Kakuyanagi, M.-C. Yeh, Y. Matsuzaki, H. Toida, H. Yamaguchi, S. Saito, A. J. Leggett, and W. J. Munro, *Nat. Commun.* **7**, 13253 (2016).
 [17] J. A. Formaggio, D. I. Kaiser, M. M. Murskyj, and T. E. Weiss, *Phys. Rev. Lett.* **117**, 050402 (2016).
 [18] E. Huffman and A. Mizel, *Phys. Rev. A* **95**, 032131 (2017).
 [19] K. Wang, C. Emary, X. Zhan, Z. Bian, J. Li, and P. Xue, [arXiv:1701.02454](https://arxiv.org/abs/1701.02454).
 [20] K. Wang, G. C. Knee, X. Zhan, Z. Bian, J. Li, and P. Xue, *Phys. Rev. A* **95**, 032122 (2017).
 [21] H. Katiyar, A. Brodutch, D. Lu, and R. Laflamme, *New J. Phys.* **19**, 023033 (2017).
 [22] A. Montina, *Phys. Rev. Lett.* **108**, 160501 (2012).
 [23] M. Wilde and A. Mizel, *Found. Phys.* **42**, 256 (2012).
 [24] G. C. Knee, S. Simmons, E. M. Gauger, J. J. Morton, H. Riemann, N. V. Abrosimov, P. Becker, H.-J. Pohl, K. M. Itoh, M. L. Thewalt, G. A. D. Briggs, and S. C. Benjamin, *Nat. Commun.* **3**, 606 (2012).
 [25] H. Katiyar, A. Shukla, K. R. K. Rao, and T. S. Mahesh, *Phys. Rev. A* **87**, 052102 (2013).
 [26] S. F. Huelga, T. W. Marshall, and E. Santos, *Phys. Rev. A* **52**, R2497 (1995).
 [27] S. Foster and A. Elby, *Found. Phys.* **21**, 773 (1991).
 [28] A. Elby and S. Foster, *Phys. Lett. A* **166**, 17 (1992).
 [29] R. Lapiedra, *Europhys. Lett.* **75**, 202 (2006).
 [30] M. Zukowski, [arXiv:1009.1749](https://arxiv.org/abs/1009.1749).
 [31] C.-M. Li, N. Lambert, Y.-N. Chen, G.-Y. Chen, and F. Nori, *Sci. Rep.* **2**, 885 (2012).
 [32] C. Emary, J. P. Cotter, and M. Arndt, *Phys. Rev. A* **90**, 042114 (2014).
 [33] R. E. George, L. M. Robledo, O. J. E. Maroney, M. S. Blok, H. Bernien, M. L. Markham, D. J. Twitchen, J. J. L. Morton,

- G. A. D. Briggs, and R. Hanson, *Proc. Natl. Acad. Sci. USA* **110**, 3777 (2013).
- [34] Y. Aharonov, D. Z. Albert, and L. Vaidman, *Phys. Rev. Lett.* **60**, 1351 (1988).
- [35] A. G. Kofman, S. Ashhab, and F. Nori, *Phys. Rep.* **520**, 43 (2012).
- [36] A. N. Jordan, A. N. Korotkov, and M. Büttiker, *Phys. Rev. Lett.* **97**, 026805 (2006).
- [37] R. Ruskov, A. N. Korotkov, and A. Mizel, *Phys. Rev. Lett.* **96**, 200404 (2006).
- [38] N. S. Williams and A. N. Jordan, *Phys. Rev. Lett.* **100**, 026804 (2008).
- [39] A. Palacios-Laloy, F. Mallet, F. Nguyen, P. Bertet, D. Vion, D. Esteve, and A. N. Korotkov, *Nat. Phys.* **6**, 442 (2010).
- [40] M. E. Goggin, M. P. Almeida, M. Barbieri, B. P. Lanyon, J. L. O'Brien, A. G. White, and G. J. Pryde, *Proc. Natl. Acad. Sci. USA* **108**, 1256 (2011).
- [41] J. Dressel, C. J. Broadbent, J. C. Howell, and A. N. Jordan, *Phys. Rev. Lett.* **106**, 040402 (2011).
- [42] Y. Suzuki, M. Iinuma, and H. F. Hofmann, *New J. Phys.* **14**, 103022 (2012).
- [43] A. Bednorz, W. Belzig, and A. Nitzan, *New J. Phys.* **14**, 013009 (2012).
- [44] S. Marcovitch and B. Reznik, [arXiv:1103.2557](https://arxiv.org/abs/1103.2557); [arXiv:1107.2186](https://arxiv.org/abs/1107.2186).
- [45] O. J. E. Maroney, *Stud. Hist. Philos. Sci. B* **58**, 41 (2017).
- [46] J. Dressel and A. N. Jordan, *Phys. Rev. A* **85**, 022123 (2012).
- [47] C. Budroni and C. Emary, *Phys. Rev. Lett.* **113**, 050401 (2014).
- [48] We note that an alternative approach to including signaling effects in LGIs has been discussed by Kujala and Dzhafarov. See, for example, J. V. Kujala and E. N. Dzhafarov, in *Contextuality from Quantum Physics to Psychology*, edited by E. Dzhafarov, S. Jordan, R. Zhang, and V. Cervantes (World Scientific, Singapore, 2015), pp. 287–308.
- [49] T. Fritz, *New J. Phys.* **12**, 083055 (2010).
- [50] C. Budroni, T. Moroder, M. Kleinmann, and O. Gühne, *Phys. Rev. Lett.* **111**, 020403 (2013).
- [51] An interesting extension would be to consider more than two experiments with differing degrees and/or types of ambiguity.
- [52] EIM does, however, follow automatically from NIM, so it can be no less plausible.