

Binding two-loop vacuum-polarization corrections to the bound-electron g factor

Ulrich D. Jentschura

Department of Physics, Missouri University of Science and Technology, Rolla, Missouri 65409-0640, USA

(Received 10 February 2009; published 10 April 2009)

We commence the evaluation of the one- and two-loop binding corrections to the g factor for an electron in a hydrogenlike system of order $\alpha^2(Z\alpha)^5$ and consider diagrams with closed fermion loops. The one-loop vacuum-polarization correction is rederived and confirmed. For the two-loop vacuum-polarization correction, due to a specific gauge-invariant set of diagrams with closed fermion loops, we find a correction $\delta g = 7.442(\alpha/\pi)^2(Z\alpha)^5$. Based on the numerical trend of the coefficients inferred from the gauge-invariant subset, we obtain a numerically large tentative estimate for the complete two-loop binding correction to the g factor (sum of self-energy and vacuum polarization).

DOI: [10.1103/PhysRevA.79.044501](https://doi.org/10.1103/PhysRevA.79.044501)

PACS number(s): 31.30.js, 12.20.Ds, 06.20.Jr, 31.15.-p

I. INTRODUCTION

The bound-electron g factor has been the subject of intense investigations over the past decade both experimentally as well as theoretically. It describes the response of the bound electron to an external homogeneous magnetic field and is naturally different from the g factor of a free electron due to the binding of the electron to the nucleus. Recent measurements for hydrogenlike ions with a spinless nucleus in the region of low nuclear charge number Z have been reported and discussed in Refs. [1–4].

For precision experiments with trapped hydrogenlike ions, the most important atomic state to be considered is the ground state, and we restrict the discussion to the g factor of the electronic ground state, for which we write $g \equiv g(1S)$. From the relativistic (Dirac) theory of the bound electron (which does not include radiative corrections), one obtains [5]

$$g = 2 - \frac{2}{3}(Z\alpha)^2 - \frac{1}{6}(Z\alpha)^4 + O(Z\alpha)^6. \quad (1)$$

Here, α is the fine-structure constant and Z is the nuclear charge number. The negative sign of the correction terms of higher order in the $Z\alpha$ expansion implies that $g < 2$ for higher nuclear charge numbers Z . Therefore, planned experiments in the high- Z region [6] have been termed 2- g experiments.

The quantum electrodynamic (QED) corrections to the bound-electron g factor can be expressed as a combined expansion in α and $Z\alpha$, where the latter parameter describes the strength of the coupling to the nucleus [7]. The first few terms in the expansion of the one-loop correction $\delta g^{(1)}$ to the bound-electron g factor (sum of self-energy and vacuum polarization) in powers of $Z\alpha$ read [8,9]

$$\delta g^{(1)} = \frac{\alpha}{\pi} \left\{ 1 + \frac{(Z\alpha)^2}{6} + (Z\alpha)^4 \left[\frac{32}{9} \ln[(Z\alpha)^{-2}] - 11.303\,191 \right] + a_{50}(Z\alpha)^5 + O(Z\alpha)^6 \right\}. \quad (2)$$

According to commonly accepted conventions, the coefficient a_{50} carries two indices, the first of which counts the power of $Z\alpha$, whereas the second counts the power of the logarithm $\ln[(Z\alpha)^{-2}]$.

The two-loop correction reads [10]

$$\delta g^{(2)} = \left(\frac{\alpha}{\pi} \right)^2 \left\{ -0.656\,958 \left[1 + \frac{(Z\alpha)^2}{6} \right] + (Z\alpha)^4 \left[\frac{56}{9} \ln[(Z\alpha)^{-2}] - 16.436\,842 + b_{50}(Z\alpha)^5 + O(Z\alpha)^6 \right] \right\}. \quad (3)$$

Our goals here are to evaluate the contribution to b_{50} due to a subset of the diagrams containing closed fermion loops and to rederive the known result for the vacuum-polarization contribution to a_{50} . We recall that according to Fig. 21 of Ref. [1], the number of two-loop diagrams contributing to the g factor is large, and the particular diagrams considered here form one of the most straightforward gauge-invariant subsets in two-loop order. As the whole set of two-loop diagrams can be broken up into smaller gauge-invariant subsets, the evaluation could be initiated by considering gauge-invariant subsets. Since the diagrams for the g factor are related to those for the Lamb shift (except for the additional presence of an external magnetic field), a by-product of our calculations is a confirmation of results obtained previously for the contribution of corresponding diagrams to the two loop, binding correction to the Lamb shift [11] of order $\alpha^2(Z\alpha)^5$.

This Brief Report is organized as follows. After a discussion of the one-loop correction in the order $\alpha(Z\alpha)^5$ (see Sec. II), we describe the two-loop calculations in the order $\alpha^2(Z\alpha)^5$ in Sec. III. Conclusions are drawn in Sec. IV.

II. ONE-LOOP CORRECTION

First, we would like to rederive the leading vacuum-polarization correction to the bound-electron g factor of order $\alpha(Z\alpha)^4$. To this end, we recall that for the interaction of an electron with a constant magnetic field, one can derive the following effective Hamiltonian based on long-wavelength quantum electrodynamics [12] for the interaction of an electron with an external static magnetic field \vec{B} ,

$$H_\sigma = e\vec{\sigma} \cdot \vec{B} \left(-\frac{1}{2m} + \frac{\vec{p}^2}{4m^3} - \frac{1}{12m^2}(\vec{r} \cdot \vec{\nabla} V) \right), \quad (4)$$

where \vec{p} is the bound-electron momentum, m is the electron mass, and V is the total static potential felt by the electron. This potential can be either the Coulomb potential, which we denote by V_C in the following, or a vacuum-polarization correction δV .

We now briefly recall how to evaluate the one-loop vacuum-polarization correction based on effective Hamiltonian (4) and on well-known formulas for vacuum-polarization effects. Indeed, we use the well-known Uehling approximation for the vacuum-polarization potential and identify the potential in Eq. (4) as $V \rightarrow \delta V \rightarrow V_U$,

$$V_U(\vec{r}) = \frac{\alpha}{\pi} \int_0^1 dv \frac{v^2(1-v^2/3)}{1-v^2} \exp(-\lambda r) \left[\frac{-Z\alpha}{r} \right], \quad (5)$$

with $\lambda = 2m/\sqrt{1-v^2}$.

The first correction E_1 to the spin-dependent magnetic-field interaction energy (and thus to the g factor) is obtained if we replace $V \rightarrow V_U$ in the third term in parentheses in Eq. (4),

$$\begin{aligned} E_1 &= \langle \phi | -\frac{e}{12m^2}(\vec{r} \cdot \vec{\nabla} V_U)(\vec{\sigma} \cdot \vec{B}) | \phi \rangle \\ &= \frac{1}{3} \langle \phi | \vec{r} \cdot \frac{\vec{\nabla} V_U}{m} | \phi \rangle \left\langle -\frac{e}{4m} \vec{\sigma} \cdot \vec{B} \right\rangle, \end{aligned} \quad (6)$$

where $|\phi\rangle$ denotes the nonrelativistic atomic ket vector corresponding to the atomic state under investigation (here, the ground state). Of course, the rightmost term in Eq. (6) is evaluated on the bound-state wave function, but we write it as being proportional to $\langle \vec{\sigma} \cdot \vec{B} \rangle$, where it is understood that for an S state, the spin is either pointing up or down. This means that the expectation value on the right-hand side is to be evaluated using the spin degrees of freedom only, and it is therefore denoted by a simple bracket. Because E_1 is a first-order spin-dependent energy correction in a uniform external magnetic field, it can be related directly to a correction to the g factor. For this purpose, we write the interactions as multiplicative corrections to the normalized interaction $-\frac{e}{4m}\vec{\sigma} \cdot \vec{B}$; the latter leads to a g factor of unity.

The correction E_1 , which is a first-order correction, now has to be supplemented by some second-order effects. Let us therefore consider the case where V in Eq. (4) represents the Coulomb potential V_C . In order to evaluate the second-order effects, we investigate the Uehling correction in conjunction with the second and the third terms in parentheses in Eq. (4), which represent corrections to the $\vec{\sigma} \cdot \vec{B}$ interaction of relative order $(Z\alpha)^2$. The perturbation to the wave function induced by the leading-order interaction $-e\vec{\sigma} \cdot \vec{B}/(2m) = -ge\vec{\sigma} \cdot \vec{B}/(4m)$ vanishes.

The first of the nonvanishing second-order effects is obtained by considering a second-order perturbation involving the Uehling potential and the second term in parentheses in Eq. (4),

$$\begin{aligned} E_2 &= 2 \langle \phi | V_U \left(\frac{1}{E-H} \right)' \left(\frac{\vec{p}^2}{4m^3} e\vec{\sigma} \cdot \vec{B} \right) | \phi \rangle \\ &= 4 \langle \phi | \frac{V_U}{m} \left(\frac{1}{E-H} \right)' V_C | \phi \rangle \left\langle -\frac{e}{4m} \vec{\sigma} \cdot \vec{B} \right\rangle. \end{aligned} \quad (7)$$

The second of these is obtained by considering again the third term in parentheses in Eq. (4), but this time acting on the Coulomb potential V in second-order perturbation theory,

$$\begin{aligned} E_3 &= 2 \langle \phi | \frac{V_U}{m} \left(\frac{1}{E-H} \right)' \left(-\frac{e}{12m} [(r \cdot \vec{\nabla}) V_C] \vec{\sigma} \cdot \vec{B} \right) | \phi \rangle \\ &= -\frac{2}{3} \langle \phi | \frac{V_U}{m} \left(\frac{1}{E-H} \right)' V_C | \phi \rangle \left\langle -\frac{e}{4m} \vec{\sigma} \cdot \vec{B} \right\rangle. \end{aligned} \quad (8)$$

Taking into account the Hellmann-Feynman theorem,

$$\left(\frac{1}{E-H} \right)' V_C | \phi \rangle = Z \frac{\partial}{\partial Z} | \phi \rangle, \quad (9)$$

the sum of the corrections $E_1 + E_2 + E_3$ leads to the known result [9],

$$\delta g = \frac{1}{3} \langle \phi | \vec{r} \cdot \frac{\vec{\nabla} V_U}{m} | \phi \rangle + \frac{10}{3} \langle \phi | \frac{V_U}{m} Z \frac{\partial}{\partial Z} | \phi \rangle. \quad (10)$$

In the lowest-order in the $Z\alpha$ expansion, Eq. (5) then immediately leads to the leading-order vacuum-polarization correction to the g factor [9],

$$\delta g_U^{(1)} = \frac{\alpha}{\pi} (Z\alpha)^4 \left(-\frac{16}{15} \right), \quad (11)$$

where the index U reminds us of the Uehling potential.

We now consider the wave function slope and the $\alpha(Z\alpha)^5$ correction. According to Schwinger's textbook [13], one can obtain the vacuum-polarization correction of order $\alpha(Z\alpha)^5$ to the Lamb shift by considering the slope of the bound-state wave function at the origin. This holds equally well for the g factor. The reason is that the bound-state wave function decays exponentially as $\exp(-Zamr)$ whereas the Uehling potential decays much faster, namely, according to Eq. (5) as $\exp(-\lambda r)$ where λ is of the order of the electron rest mass. In the resulting product

$$\begin{aligned} |\psi(\vec{r})|^2 V_U(r) &\sim \exp(-Zamr - \lambda r) \\ &= \exp(-\lambda r) [1 - Zamr + O(r^2)], \end{aligned} \quad (12)$$

one can thus expand in the first argument of the exponential using $\lambda \gg Zam$. The correction term $1 - Zamr$ corresponds to the slope of the wave function at the origin. A straightforward evaluation gives the following vacuum-polarization correction for the ground state:

$$\delta g_{VP}^{(1)} = \frac{\alpha}{\pi} (Z\alpha)^4 \left(-\frac{16}{15} + \frac{5\pi}{9} (Z\alpha) \right), \quad (13)$$

which includes the correction of relative order $Z\alpha$. We here confirm the result in Ref. [14]. For completeness, it is useful to recall the corresponding one-loop vacuum-polarization correction to the Lamb shift, which reads [13]

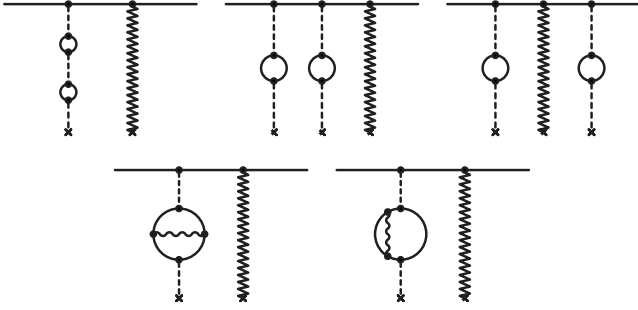

FIG. 1. Feynman diagrams for the two-loop vacuum-polarization corrections to the bound-electron g factor. The first of these is the loop-after-loop Uehling vacuum-polarization correction and gives a contribution of $-368\pi/1701$ in units of $(\alpha/\pi)^2(Z\alpha)^5$ for the g factor. The sum of the second and third diagrams (upper row), which are iterated one-loop perturbations, yields a contribution of $-851\pi/6804$ in the same units. The two last two diagrams (lower row) are Källén-Sabry diagrams. They lead to a g factor correction of $\pi(125\,176/19\,845 + 832 \ln 2/189 - 400\pi/189)$.

$$\delta E_{VP}^{(1)} = \frac{\alpha}{\pi} (Z\alpha)^4 m \left(-\frac{4}{15} + \frac{5\pi}{48} (Z\alpha) \right). \quad (14)$$

This concludes the consideration of the one-loop vacuum-polarization correction of order $\alpha(Z\alpha)^5$ to the g factor.

III. TWO-LOOP CORRECTION

We now discuss the two-loop calculation. The leading-order result [10] follows as we replace the Uehling potential V_U in Eq. (10) by the Källén-Sabry [15] term. It reads

$$\delta g_{KS} = \left(\frac{\alpha}{\pi} \right)^2 (Z\alpha)^4 \left(-\frac{328}{81} \right). \quad (15)$$

The Källén-Sabry term [15] is a genuine two-loop effect, and one might wonder why the iterated one-loop diagrams do not also contribute in the order $\alpha^2(Z\alpha)^4$ (these correspond to the second and third diagrams in Fig. 1). However, the first-order correction to the wave function induced by the leading-order magnetic interaction $-e\vec{\sigma}\cdot\vec{B}/(2m)$ vanishes, and the remaining contribution due to the iterated Uehling term cancels explicitly in third-order perturbation theory because the term with the magnetic interaction “in the middle” cancels against the derivative term obtained by considering the derivative of the second-order Uehling correction with respect to the bound-state energy.

For some of the diagrams in Fig. 1, the g factor correction of order $\alpha^2(Z\alpha)^5$ can be obtained by expanding the wave function about the origin, as it was done for the one-loop theory. An example is the first diagram in Fig. 1, which can be expressed as the expectation value of the loop-after-loop Uehling potential, evaluated with wave functions perturbed by the magnetic interaction. For the other diagrams, the calculation is more complicated. In particular, since the iterated Uehling correction (second and third diagrams in the first row in Fig. 1) contributes at the order of $\alpha^2(Z\alpha)^5$, one cannot avoid the complete calculation of the (first-order) perturbation to the wave function by the Uehling correction, which

involves exponentials, exponential integrals, logarithms, and powers of the radial variable. For example, the magnetic interaction in the middle vertex demands a further integration over the radial coordinate. The further calculation proceeds along the lines outlined in Ref. [11] for the two-loop vacuum-polarization corrections to the Lamb shift.

We finally obtain for the two-loop binding contribution $\delta g_{VP}^{(2)}$ due to the diagrams in Fig. 1,

$$\begin{aligned} \delta g_{VP}^{(2)} &= \left(\frac{\alpha}{\pi} \right)^2 (Z\alpha)^4 \left[-\frac{328}{81} + (Z\alpha)\pi \left(\frac{1\,420\,807}{238\,140} \right. \right. \\ &\quad \left. \left. + \frac{832}{189} \ln 2 - \frac{400}{189}\pi \right) \right] \\ &= \left(\frac{\alpha}{\pi} \right)^2 (Z\alpha)^4 [-4.049 + 7.442(Z\alpha)]. \end{aligned} \quad (16)$$

The numerical coefficient of the $(Z\alpha)$ correction is rather large mainly because it has a factor π in the numerator.

Just as for the one-loop calculation, it is useful to compare our results to those for the Lamb shift, selecting the corresponding set of diagrams. For the Lamb shift, we can identify the diagrams corresponding to those in Fig. 1 by simply eliminating the interaction with the external magnetic field. The resulting diagrams after this removal operation are equivalent to the diagrams labeled as IV and VI in Ref. [11]. The corresponding contribution to the Lamb shift is [11,16]

$$\begin{aligned} \delta E_{VP}^{(2)} &= \left(\frac{\alpha}{\pi} \right)^2 m (Z\alpha)^4 \left[-\frac{82}{81} + (Z\alpha)\pi \left(\frac{7421}{6615} \right. \right. \\ &\quad \left. \left. + \frac{52}{63} \ln 2 - \frac{25}{63}\pi \right) \right] \\ &= \left(\frac{\alpha}{\pi} \right)^2 (Z\alpha)^4 [-1.012 + 1.405(Z\alpha)], \end{aligned} \quad (17)$$

and we have verified it using our approach. This concludes our two-loop vacuum-polarization calculations.

IV. SUMMARY

In this Brief Report, we describe the evaluation of a part of the binding vacuum-polarization correction to the bound-electron g factor. The vacuum-polarization corrections represent a preparatory calculation for the self-energy corrections, which are much more difficult to evaluate. In view of the multitude of terms generated in comparison to the corresponding self-energy correction to the Lamb shift of order $\alpha(Z\alpha)^5$ and in view of the additional complexity of the calculation due to the added external magnetic field, considerable difficulties are expected.

It may, already at this point, be permitted to speculate a little about the magnitude of the complete correction to the g factor of order $\alpha^2(Z\alpha)^5$, which is less than an estimate but perhaps more than just guesswork. Namely, we observe there appears to be a rather universal factor in the range of 3.5–5.5 by which the g factor coefficients of a given order in the $Z\alpha$ expansion are larger than the corresponding Lamb-shift coefficients for the ground state. In particular, we compare in

the order $\alpha(Z\alpha)^4$ the coefficient $-16/15$ in Eq. (13) to the coefficient $-4/15$ in Eq. (14) (the g factor coefficient is larger than the Lamb-shift coefficient by a relative factor 4). At relative order $Z\alpha$, the relative factor is 5.33 (the coefficients are $5\pi/9$ versus $5\pi/48$). For the g factor at two-loop order, the relative factor at $\alpha^2(Z\alpha)^5$ is 5.30, as evident from Eqs. (16) and (17). A factor in the range of 3.5–5.5 also appears for the self-energy corrections. We recall that the complete two-loop correction to the Lamb shift in the order $\alpha^2(Z\alpha)^5$ is [17–20]

$$\delta E_5^{(2)} = -21.55 \left(\frac{\alpha}{\pi} \right)^2 (Z\alpha)^5 m. \quad (18)$$

Our “educated guess” for the complete correction to the g factor thus is

$$\delta g_5^{(2)} = C \left(\frac{\alpha}{\pi} \right)^2 (Z\alpha)^5, \quad -118 < C < -75. \quad (19)$$

The magnitude of this estimate of the coefficient generates obvious interest.

ACKNOWLEDGMENTS

The author acknowledges helpful discussions with K. Pachucki and E. Remiddi and helpful remarks by an anonymous referee.

-
- [1] T. Beier, Phys. Rep. **339**, 79 (2000).
 - [2] H. Häffner, T. Beier, N. Hermanspahn, H. J. Kluge, W. Quint, S. Stahl, J. Verdú, and G. Werth, Phys. Rev. Lett. **85**, 5308 (2000).
 - [3] T. Beier, H. Häffner, N. Hermanspahn, S. G. Karshenboim, H. Jürgen Kluge, W. Quint, S. Stahl, J. Verdú, and G. Werth, Phys. Rev. Lett. **88**, 011603 (2001).
 - [4] J. Verdú, S. Djekić, H. Häffner, S. Stahl, T. Valenzuela, M. Vogel, G. Werth, T. Beier, H. J. Kluge, and W. Quint, Phys. Rev. Lett. **92**, 093002 (2004).
 - [5] G. Breit, Nature (London) **122**, 649 (1928).
 - [6] V. M. Shabaev, D. A. Glazov, N. S. Oreshkina, A. V. Volotka, G. Plunien, H. J. Kluge, and W. Quint, Phys. Rev. Lett. **96**, 253002 (2006).
 - [7] U. D. Jentschura and J. Evers, Can. J. Phys. **83**, 375 (2005).
 - [8] K. Pachucki, U. D. Jentschura, and V. A. Yerokhin, Phys. Rev. Lett. **93**, 150401 (2004); **94**, 229902(E) (2005).
 - [9] S. G. Karshenboim, Phys. Lett. A **266**, 380 (2000).
 - [10] K. Pachucki, A. Czarnecki, U. D. Jentschura, and V. A. Yerokhin, Phys. Rev. A **72**, 022108 (2005).
 - [11] K. Pachucki, Phys. Rev. A **48**, 2609 (1993).
 - [12] K. Pachucki, Phys. Rev. A **69**, 052502 (2004).
 - [13] J. Schwinger, *Particles, Sources and Fields* (Addison-Wesley, Reading, MA, 1970).
 - [14] S. G. Karshenboim, V. G. Ivanov, and V. M. Shabaev, Can. J. Phys. **79**, 81 (2001).
 - [15] G. Källén and A. Sabry, K. Dan. Vidensk. Selsk. Mat. Fys. Medd. **29**, 17 (1955).
 - [16] M. I. Eides, H. Grotch, and D. A. Owen, Phys. Lett. B **294**, 115 (1992).
 - [17] K. Pachucki, Ann. Phys. (N.Y.) **226**, 1 (1993).
 - [18] K. Pachucki, Phys. Rev. Lett. **72**, 3154 (1994).
 - [19] M. I. Eides and V. A. Shelyuto, Phys. Rev. A **52**, 954 (1995).
 - [20] M. I. Eides, H. Grotch, and V. A. Shelyuto, Phys. Rev. A **55**, 2447 (1997).