

**Hybrid quantum computation in quantum optics**P. van Loock,<sup>1,2,\*</sup> W. J. Munro,<sup>1,3</sup> Kae Nemoto,<sup>1</sup> T. P. Spiller,<sup>3</sup> T. D. Ladd,<sup>1,4</sup> Samuel L. Braunstein,<sup>5</sup> and G. J. Milburn<sup>6</sup><sup>1</sup>*National Institute of Informatics, 2-1-2 Hitotsubashi, Chiyoda-ku, Tokyo 101-8430, Japan*<sup>2</sup>*Optical Quantum Information Theory Group, Institute of Theoretical Physics I and Max-Planck Research Group, Institute of Optics, Information and Photonics, Universität Erlangen-Nürnberg, Staudtstrasse 7/B2, 91058 Erlangen, Germany*<sup>3</sup>*Hewlett-Packard Laboratories, Filton Road, Stoke Gifford, Bristol BS34 8QZ, United Kingdom*<sup>4</sup>*Edward L. Ginzton Laboratory, Stanford University, Stanford, California 94305-4088, USA*<sup>5</sup>*Computer Science, University of York, York YO10 5DD, United Kingdom*<sup>6</sup>*Centre for Quantum Computer Technology, Department of Physics, University of Queensland, Brisbane, Australia*

(Received 9 August 2006; revised manuscript received 4 July 2008; published 1 August 2008)

We propose a hybrid quantum computing scheme where qubit degrees of freedom for computation are combined with quantum continuous variables for communication. In particular, universal two-qubit gates can be implemented deterministically through qubit-qubit communication, mediated by a continuous-variable bus mode (“qubus”), without direct interaction between the qubits and without any measurement of the qubus. The key ingredients are controlled rotations of the qubus and unconditional qubus displacements. The controlled rotations are realizable through typical atom-light interactions in quantum optics. For such interactions, our scheme is universal and works in any regime, including the limits of weak and strong nonlinearities.

DOI: [10.1103/PhysRevA.78.022303](https://doi.org/10.1103/PhysRevA.78.022303)

PACS number(s): 03.67.Hk, 03.67.Mn, 42.50.Pq

**I. INTRODUCTION**

There are various proposals for realizing quantum computers [1,2]. At the few-qubit level, some proposals have been demonstrated already in the laboratory. These proof-of-principle demonstrations include schemes based on, for instance, trapped ions [3], linear optics [4,5], and nuclear spins in liquid-state molecules [6]. For the long-term prospects of scalability, “solid-state” qubits are also of great interest. For their realization, the toolbox and all the fabrication and manufacturing expertise developed for conventional information technology could be exploited. However, at present, such solid-state-based schemes lag behind other approaches and are at best at the one-or two-qubit demonstration level.

For processing photonic qubits directly in an optical quantum computer, the large Kerr-type nonlinearities needed for a two-qubit gate are hard to obtain with single photons. A possible way to circumvent this obstacle is to apply only linear transformations, supplemented by measurement-induced nonlinearities [4,5]. The simplest forms of these linear-optical gates have been realized already [5]. There are also proposals that combine the advantages of the solid-state and the optical approaches; the main idea of these schemes is to use single photons as a bus to mediate interactions between non-nearest neighbors of solid-state qubits [7–12]. In principle, this enables one to add arbitrarily many qubits to a system, in order to achieve universality and scalability. Two-qubit gates can be achieved for any pair and there is no need for the qubits to be so close together such that individual addressing is no longer possible.

Significant difficulties with single-photon-based buses arise due to the demanding requirements on the generation and detection of the photons. In particular, successful near-deterministic gate performance depends on efficient detec-

tors that unambiguously detect a single photon. As a result, with typically low practical detector efficiencies the gates will be highly nondeterministic. However, efficient local gates are essential ingredients in, for example, long-distance quantum communication via quantum repeaters [13]. In such schemes, inefficient gates require more expensive quantum resources. In addition, measurement-based gates are typically slow, limited by the measurement speed. It is therefore desirable to circumvent the need for measurements.

All of the above-mentioned proposals for realizing a quantum computer rely exclusively on discrete variables (DVs). The quantum information is encoded into qubits (actual, or effective—a two-dimensional subspace in a larger Hilbert space) and, in some cases, qubits are also used as a bus to mediate interactions. This includes the original ion-trap proposal [3] where the two lowest states of a vibrational mode mediate a gate between two ion qubits (based on two internal ion states). There are now also efficient and practical approaches to quantum communication based on *continuous variables* (CVs) [14]. Inspired by these results, and in order to avoid both direct qubit-qubit interactions and the use of single photons, here we propose the following “hybrid quantum computer”: universal two-qubit gates will be achieved indirectly through the interaction between the qubits and the quadrature phase amplitude of a common bosonic mode. The CV mode plays the role of a communication bus which we call a “qubus.” This approach brings together the best of both worlds, utilizing DVs for processing and CVs for communication.

The idea of the CV qubus computer has been applied to ion traps [15–18] and other systems [19], but here we focus on a *quantum optical* realization. In this approach, the qubits are either atomic or photonic, and the qubus is an electromagnetic field mode; the CVs are the phase-space variables of this field mode. Although efficient homodyne detection of certain phase-space variables (quadratures) is possible, no measurement will be needed in our scheme. By design, under ideal conditions, the bus mode disentangles automatically

\*pvanloock@optik.uni-erlangen.de

from the qubits after a sequence of interactions. Measurement-induced errors are thus avoided and the gates become deterministic, requiring neither measurement-result-dependent postselection nor any feedforward operations on the qubits. Moreover, we make no assumptions about the strength of the qubit-qubus interactions; our scheme works in any regime, including the limits of weak and strong nonlinearities. The proposal here relies on two new important concepts: the *exact* simulation of controlled phase-space displacements via controlled rotations and uncontrolled displacements; and an *efficient* all-cavity implementation of this simulation.

In contrast to existing CV-mediated proposals for measurement-free ion-trap gates based upon conditional displacements [15–18], our proposed two-qubit gate is based on *conditional rotations*. These are obtainable from the fundamental Jaynes-Cummings interaction  $\hbar g(a^\dagger\sigma_- + a\sigma_+)$  in the dispersive limit [20], which gives

$$H_{\text{int}} = \hbar\chi\sigma_z a^\dagger a. \quad (1)$$

Here,  $a$  ( $a^\dagger$ ) refers to the annihilation (creation) operator of an electromagnetic field mode in a cavity and  $\sigma_z = |0\rangle\langle 0| - |1\rangle\langle 1|$  is the corresponding qubit operator from the set of Pauli operators  $\{\sigma_x, \sigma_y, \sigma_z\}$  for a two-level atom in the cavity (with ground state  $|0\rangle$  and excited state  $|1\rangle$ ) [21];  $\sigma_+$  ( $\sigma_-$ ) are the raising (lowering) operators of the qubit. The atom-light coupling strength is determined via the parameter  $\chi = g^2/\Delta$ , where  $2g$  is the vacuum Rabi splitting for the dipole transition and  $\Delta$  is the detuning between the dipole transition and the cavity field. The Hamiltonian in Eq. (1) generates a conditional phase rotation of the field mode, dependent upon the state of the atomic qubit. Note that the dispersive interaction for a high-fidelity conditional rotation does not require strong coupling; the only requirement is a sufficiently large cooperativity parameter [22].

It has been pointed out [23] that a suitable set of Hamiltonian terms, including conditional rotations and unconditional displacements  $\{\sigma_x a^\dagger a, \sigma_z a^\dagger a, x\}$ , is, in principle, sufficient for universal quantum computation. Here our main concern is how to efficiently utilize these universal resources. Throughout, we use the definition for quadrature operators  $X(\phi) = (a^\dagger e^{i\phi} + a e^{-i\phi})$  such that  $X(0) \equiv x$  and  $X(\pi/2) \equiv p$  play the roles of “position” and “momentum,” respectively, with  $[x, p] = 2i$  for  $[a, a^\dagger] = 1$ . We now demonstrate how a universal two-qubit gate can be implemented via the Jaynes-Cummings-type interaction from Eq. (1) and additional, uncontrolled displacements.

For this purpose, after briefly introducing geometric phase gates in Sec. II, we will first describe in Sec. III how a two-qubit gate can be realized through controlled phase-space displacements of a single-mode qubus conditioned upon the state of the atomic qubits. Then in Sec. IV we will demonstrate how to, in principle, perfectly simulate a controlled displacement via controlled rotations and uncontrolled displacements. We then discuss schemes in which the inefficient coupling of the qubus mode into and out of the cavities is minimized through an all-cavity-based implementation of the uncontrolled displacements via a classical

pump. Finally, in Sec. V, we address the issue of inefficiencies due to remaining noise sources and photon losses.

## II. GEOMETRIC PHASE GATES

Our two-qubit gate relies upon the basic principle that a CV mode acquires a phase shift whenever it goes along a closed loop in phase space. This phase shift only depends on the area of the loop and not on its form [23] and it originates from the fact that for any sequence of two displacements, the total displacement operator contains an extra phase factor,

$$D(\beta_1)D(\beta_2) = \exp[i \text{Im}(\beta_1\beta_2^*)]D(\beta_1 + \beta_2). \quad (2)$$

Here  $D(\beta) = \exp(\beta a^\dagger - \beta^* a)$  is the usual quantum optical displacement operator. In this sense such a two-qubit gate can be regarded as a geometric phase gate [23]. In Ref. [19], it was shown how a conditional phase gate on qubits can be realized by creating almost closed loops in phase space through controlled rotations and uncontrolled displacements. However, this gate is imperfect, as even under ideal conditions the CV qubus does not disentangle completely from the qubits, leading to an intrinsic dephasing error. Here, instead of directly applying the interaction in Eq. (1) to create a closed path, we instead simulate controlled displacements via the controlled rotations in Eq. (1). With controlled displacements available it is straightforward to implement a conditional phase gate, as we now describe.

## III. TWO-QUBIT GATE VIA CONTROLLED DISPLACEMENTS

Let us assume that an arbitrary two-qubit state enters the gate such that the total initial state (of the two-qubit–qubus system) may be written as

$$(c_1|00\rangle + c_2|01\rangle + c_3|10\rangle + c_4|11\rangle)|\text{qubus}\rangle, \quad (3)$$

with a qubus-probe mode initially in an arbitrary state  $|\text{qubus}\rangle$ . The two-qubit gate follows from four conditional displacements. The sequence of operations is shown in Fig. 1(a). This defines the total unitary operator

$$U_{\text{tot}} \equiv D(i\beta_2\sigma_{z2})D(\beta_1\sigma_{z1})D(-i\beta_2\sigma_{z2})D(-\beta_1\sigma_{z1}). \quad (4)$$

Using Eq. (2), it is straightforward to show that

$$U_{\text{tot}} = \exp[2i \text{Re}(\beta_1^*\beta_2)\sigma_{z1}\sigma_{z2}]. \quad (5)$$

Apparently, when this operator acts on the two-qubit–qubus system, the only effect is the generation of phase factors conditional on the two-qubit state. Although it is entangled with the qubits during the gate, the qubus mode finishes in its initial state, disentangled from the qubits. The evolution does not depend on this qubus state—a convenient choice would be a coherent state [24].

For the case of real  $\beta_1$  and  $\beta_2$ , the effect of the total operation on a bus coherent state, conditional on the state of the qubits, is illustrated in Fig. 1(b). By choosing  $\beta_1\beta_2 = \pi/8$ , a total initial state as in Eq. (3) gives a final pure two-qubit state of

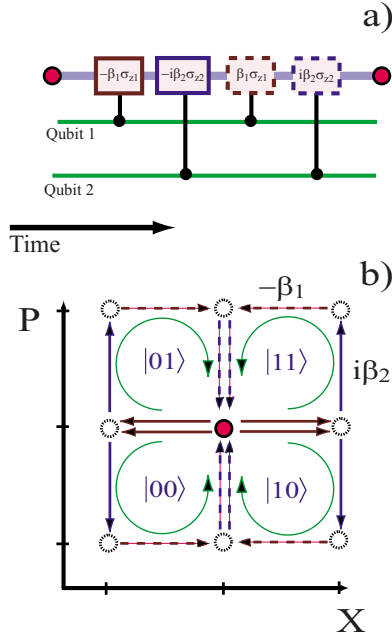

FIG. 1. (Color online) (a) Circuit diagram of a universal two-qubit gate based on controlled displacements between the qubits and the probe bus. (b) Schematic phase-space evolution of a coherent qubus amplitude (with the  $\beta$ 's chosen real), depending on the four basis states of the two qubits.

$$e^{-i\pi/4}U \otimes U(c_1|00\rangle + c_2|01\rangle + c_3|10\rangle - c_4|11\rangle), \quad (6)$$

where  $U \equiv e^{i(\pi/4)\sigma_z}$ . Thus, up to a global phase and local unitaries, we obtain a controlled-phase gate.

#### IV. TWO-QUBIT GATE VIA CONTROLLED ROTATIONS

So far we have assumed that we can perform conditional displacements in order to construct the operation  $U_{\text{tot}}$  of Eq. (4). In quantum optics, it is hard to generate such conditional displacements directly through photon-atom or photon-photon interactions. However, the Jaynes-Cummings-type interaction of Eq. (1) is readily available. We now show that this interaction is sufficient to generate the required conditional displacements. More specifically, in order to effectively simulate a controlled displacement via a series of interactions of the type of Eq. (1), the qubus is not assumed to be a cavity mode, but rather an optical pulse traveling back and forth between two cavities in which the two atomic qubits are placed. This approach circumvents the complication of addressing the two qubits individually when they are stored in the same cavity. However, coupling the optical pulses in and out of the two cavities will be subject to photon loss. We address this issue in more detail in Sec. V. In our approach, no approximations will be needed, so our method is applicable to any regime of the interaction in Eq. (1), including the weak and strong coupling limits.

We define conditional rotations as generated by Eq. (1), with an effective interaction time  $\chi t \equiv \theta$ . Consider the following operation:

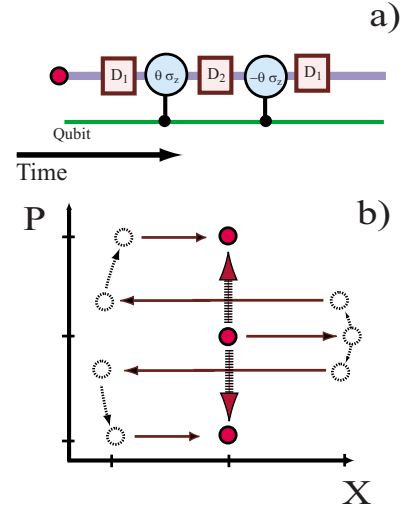

FIG. 2. (Color online) (a) Circuit diagram for an effective controlled displacement constructed from unconditional displacements and controlled rotations. (b) Schematic phase-space evolution of a coherent qubus amplitude during the controlled displacement.

$$U \equiv D(\alpha \cos \theta) e^{-i\theta \sigma_z a^\dagger a} D(-2\alpha) e^{i\theta \sigma_z a^\dagger a} D(\alpha \cos \theta), \quad (7)$$

consisting of unconditional displacements and conditional rotations. Using  $e^{-i\theta a^\dagger a} a e^{i\theta a^\dagger a} = a e^{i\theta}$ , hence  $e^{-i\theta a^\dagger a} D(\alpha) e^{i\theta a^\dagger a} = D(\alpha e^{i\theta})$ , and the rule in Eq. (2), we find that the sequence in Eq. (7) *exactly* realizes a conditional displacement such that

$$U = D(2i\alpha \sin \theta \sigma_z). \quad (8)$$

Figure 2 illustrates the sequence of unconditional displacements and controlled rotations to simulate a controlled displacement.

The resultant operation in Eq. (8) corresponds to a conditional displacement by  $2i\alpha \sin \theta$ . The entire sequence of Eq. (4) can now be achieved through unconditional displacements and controlled rotations of the probe via the Jaynes-Cummings-type interaction from Eq. (1). This provides an exact mechanism to create the controlled phase gate. Assuming  $\beta_1 = \beta_2 = \sqrt{\pi}/8$ , the strength of the conditional displacements for simulating the conditional displacements is determined by the parameter  $d \equiv 2|\alpha| \sin \theta = \sqrt{\pi}/8 \approx 0.6$ . For example, with a Jaynes-Cummings coupling and interaction time corresponding to  $\theta \sim 10^{-2}$ , unconditional displacements of about  $|\alpha|^2 \sim 10^4$  photons are needed. However, we may also satisfy  $d \approx 0.6$  using strong nonlinearities,  $\theta \sim \pi/2$  with weak qubus displacements of the order  $|\alpha| \sim 1$ .

Recall that in our simplified single-mode treatment, where the qubus pulse is described by a single optical mode, the effective phase rotation corresponds to  $\theta = \chi t$  with  $\chi = g^2/\Delta$ . Therefore, in terms of the actual physical parameters (Rabi splitting  $2g$ , detuning  $\Delta$ , etc.), there are various regimes to realize either weak (intermediate) coupling or strong coupling. In fact, the resulting coupling will also depend on the interaction time and hence on the cavity decay rates and the chosen pulse widths. In order to give realistic values for these experimental parameters, one should consider a multi-

mode model for the dispersive interaction including a time-(frequency-) dependent qubus field. For the weak (intermediate) regime, assuming  $\theta \ll 1$ , such a multimode treatment was given in Ref. [22]. The conclusion there is that the fidelity of the controlled-phase gate (through dispersive interaction) scales roughly as  $e^{-d^2/\Phi}$ , with  $\Phi$  the cooperativity parameter. Thus, in the intermediate regime, a sufficiently large  $\Phi$  is crucial. The cooperativity  $\Phi$  itself depends on various parameters and is proportional to the coupling strength into the desired output mode (desired decay rate versus undesired decay rate,  $\kappa/\gamma$ ), the internal quantum efficiency of the emitter, the inverse cavity volume, and the cavity  $Q$  value. Relevant values of these parameters for several systems including flourine donor in ZnSe and trapped ions can be found in Ref. [22].

In the case of strong coupling,  $\theta \sim \pi/2$ , the conclusions of Ref. [22] do not directly apply (in fact, the strong regime is not relevant there, as only approximate qubus gates are considered, requiring sufficiently small  $\theta$  values). Again, various choices of pulse widths, cavity decay rates, etc., may lead to the desired coupling and phase rotations. A rough estimate of the scaling including explicit values for the experimental parameters in this regime should again be based upon a multimode analysis, which is beyond the scope of the present paper.

We shall now compare the controlled-phase gate proposed here to the one described in Ref. [19]. Two crucial differences exist, both of which highlight the advantages of the present gate.

(1) First and foremost the gate of Ref. [19] is only approximate. It has an intrinsic error since the qubus probe does not completely disentangle from the qubits, causing a dephasing effect on the qubits. To keep this error small requires  $|\alpha|\theta^2 \ll 1$ , so the gate works only when  $\theta \ll 1$ . The gate presented here does not have this limitation. In this sense, our scheme here is universal and can be applied to various physical systems, in any coupling regime.

(2) The second difference is important from a practical point of view and relates to the local single-qubit rotations needed to realize the gate in (6). The gate in Ref. [19] requires single-qubit rotations of the form  $e^{i|\alpha|^2\theta\sigma_z}$ . This places considerable sensitivity on  $\alpha$  and  $\theta$ , requiring them to be known accurately enough to perform single-qubit operations that scale as  $|\alpha|^2\theta$ . In the gate presented here we require only a unitary of the form  $e^{i(\pi/4)\sigma_z}$ , which is independent of both  $\alpha$  and  $\theta$  and thus much less demanding.

In order to accomplish the sequence  $U_{\text{tot}}$  in Eq. (4) via the operation  $\mathcal{U}$  from Eqs. (7) and (8), it appears to be necessary to couple the qubus mode out of the cavity and back into it whenever an unconditional displacement must be applied via an external local oscillator field. However, this rather inefficient feature can be avoided in an *all-cavity-based* implementation of  $\mathcal{U}$ . A very natural way to generate the unconditional displacements is to drive the qubus mode directly with an intense classical pump. Such driving can be represented by the Hamiltonian  $H_d = \hbar\epsilon X(\phi)$ , with  $\epsilon$  real, effectively resembling a phase-space displacement. For instance, with  $\phi = 0$ , our system Hamiltonian is of the form

$$H(\epsilon, \chi\sigma_z) = \hbar\epsilon(a^\dagger + a) + \hbar\chi a^\dagger a \sigma_z. \quad (9)$$

Now applying this operation  $U(\epsilon, \chi\sigma_z) = \exp[-(i/\hbar)H(\epsilon, \chi\sigma_z)t]$  for a time  $t$  followed by  $U(\epsilon, -\chi\sigma_z)$  [25] for the same time  $t$  implements an effective operation of the form

$$D_{\sigma_z} = D\left(\frac{2\epsilon\sigma_z}{\chi}(1 - e^{i\chi t\sigma_z})\right). \quad (10)$$

This can be expressed in terms of a controlled displacement  $D[(2\epsilon\sigma_z/\chi)(1 - \cos \chi t)]$  and an unconditional displacement  $D[(2i\epsilon/\chi)\sin \chi t]$  which does not affect the operation of the gate [26]. In fact, these unconditional displacements are undone by further conditional operations and so our controlled displacement can be reduced to just two operations. The entire two-qubit gate,  $U_{\text{tot}}$ , as described in Eq. (4), then requires only eight operations in total.

An alternative approach would be to have a driving field on the qubit. Consider a Hamiltonian of the form  $H = \hbar\omega_0 a^\dagger a + \hbar\Omega\sigma_z + H_{j_c} + H_d$  where  $H_{j_c} = \hbar g(a^\dagger\sigma_- + a\sigma_+)$  is the Jaynes-Cummings Hamiltonian and  $H_d = \hbar\epsilon(e^{-i\phi(t)}\sigma_+ + e^{i\phi(t)}\sigma_-)$  is a time-dependent driving of the qubit. By choosing  $\phi(t)$  to be rapidly oscillating, one can derive an effective interaction Hamiltonian of the form  $H_{\text{int}} = \hbar[g\epsilon/(\omega_0 - \Omega)](a^\dagger + a)\sigma_z$ . The appropriate choice for  $\phi(t)$  is complicated and generally needs to be found by a numerical optimization.

## V. EFFECT OF QUBUS PHOTON LOSSES

The all-cavity-based approach described in the preceding section enables us to reduce the degrading effect of photon losses, as it is no longer needed to couple the optical pulses out of the cavities in order to implement uncontrolled phase-space-displacements. Nonetheless, the sequence  $U_{\text{tot}}$  in Eq. (4) still requires coupling the qubus pulses in and out of two cavities to accomplish an interaction with both qubits placed in different cavities. Let us briefly discuss this issue regarding the robustness of our two-qubit gate against noise and errors, in particular, caused by photon losses in the qubus mode [27].

A simple loss model reflects part of the qubus mode from a beam splitter into a second mode that represents the environment. In this case, the controlled displacements  $D(\beta\sigma_z)$  can be described as acting upon both the qubus mode  $D_1(\sqrt{1-\eta^2}\beta\sigma_z)$  and the loss mode  $D_2(\eta\beta\sigma_z)$ , where  $\eta$  is the reflectivity parameter. The first observation is that the controlled displacements on the qubus mode are no longer exactly those required, leading to a smaller phase shift and an error in the gate. It is also possible that the qubus mode will not disentangle exactly from the qubits, if the phase-space loops the qubus traverses do not quite close. As long as the degree of loss is known, these two effects can be eliminated by increasing the amplitude  $\beta'$  of the controlled displacement such that  $\beta = \sqrt{1-\eta^2}\beta'$ . The most important effect to consider is therefore the controlled displacements acting on the loss mode, which cause a dephasing effect on the two-qubit state. This effect scales as  $\eta^2\alpha^2\sin^2\theta$  and thus for  $\eta$  small ( $\eta \ll 1$ ) this dephasing effect is minimal [recall that  $\beta \approx O(1)$ ]. Typically, with current technology, coupling ineffi-



ciencies are quite high; hence assuming  $\eta \ll 1$  may seem unreasonable. Indeed, this effect represents the main complication for our current scheme. However, apart from potential improvements on the experimental side, further theoretical research may render our approach more feasible. For instance, the sequence in Eqs. (4), (7), and (8) provides only an upper bound on the resources needed to realize our qubus-mediated gate. We hope that possible further simplifications of this gate, supplemented by, for example, quantum error correction encoding on either the qubit or the qubus level, will render the current hybrid proposal a promising alternative to nonhybrid schemes.

## VI. CONCLUSION

In conclusion, we have demonstrated how to implement universal two-qubit gates using fundamental atom-light inter-

actions in quantum optics, through qubus-mediated qubit-qubit communication and without direct interaction between the qubits. In this hybrid scheme, the only required interactions lead to controlled rotations of a continuous-variable qubus mode, conditioned on the state of the qubits. Our scheme is universal in the sense that any regime is allowed for the controlled rotations, including interactions in the limit of weak or strong nonlinearities. The resulting phase gate is deterministic and measurement-free, and thus represents a promising approach to implementing quantum logic.

## ACKNOWLEDGMENTS

We thank R. van Meter and P. L. Knight for valuable discussions. This work was supported in part by MEXT in Japan, the EU project QAP, and the ARC in Australia.

- 
- [1] *Experimental Proposals for Quantum Computers*, edited by S. Braunstein and H.-K. Lo, special issue of *Fortschr. Phys.* **48**, 9 (2000).
  - [2] T. P. Spiller, W. J. Munro, S. D. Barrett, and P. Kok, *Contemp. Phys.* **46**, 407 (2005).
  - [3] J. I. Cirac and P. Zoller, *Phys. Rev. Lett.* **74**, 4091 (1995).
  - [4] E. Knill, R. Laflamme, and G. J. Milburn, *Nature (London)* **409**, 46 (2001).
  - [5] Pieter Kok, W. J. Munro, Kae Nemoto, T. C. Ralph, Jonathan P. Dowling, and G. J. Milburn, *Rev. Mod. Phys.* **79**, 135 (2007).
  - [6] N. A. Gershenfeld and I. L. Chuang, *Science* **275**, 350 (1997); D. Cory, A. Fahmy, and T. Havel, *Proc. Natl. Acad. Sci. U.S.A.* **94**, 1634 (1997).
  - [7] J. I. Cirac, P. Zoller, H. J. Kimble, and H. Mabuchi, *Phys. Rev. Lett.* **78**, 3221 (1997).
  - [8] S. Bose, P. L. Knight, M. B. Plenio, and V. Vedral, *Phys. Rev. Lett.* **83**, 5158 (1999).
  - [9] L.-M. Duan and H. J. Kimble, *Phys. Rev. Lett.* **90**, 253601 (2003).
  - [10] D. E. Browne, M. B. Plenio, and S. F. Huelga, *Phys. Rev. Lett.* **91**, 067901 (2003).
  - [11] Y. L. Lim, A. Beige, and L. C. Kwek, *Phys. Rev. Lett.* **95**, 030505 (2005).
  - [12] S. D. Barrett and P. Kok, *Phys. Rev. A* **71**, 060310(R) (2005).
  - [13] H.-J. Briegel, W. Dür, J. I. Cirac, and P. Zoller, *Phys. Rev. Lett.* **81**, 5932 (1998).
  - [14] S. L. Braunstein and P. van Loock, *Rev. Mod. Phys.* **77**, 513 (2005).
  - [15] G. J. Milburn, e-print arXiv:quant-ph/9908037.
  - [16] K. Mølmer and A. Sørensen, *Phys. Rev. Lett.* **82**, 1835 (1999).
  - [17] A. Sørensen and K. Mølmer, *Phys. Rev. A* **62**, 022311 (2000).
  - [18] G. J. Milburn, S. Schneider, and D. F. V. James, *Fortschr. Phys.* **48**, 801 (2000).
  - [19] T. P. Spiller, K. Nemoto, S. L. Braunstein, W. J. Munro, P. van Loock, and G. J. Milburn, *New J. Phys.* **8**, 30 (2006).
  - [20] For example, Wolfgang P. Schleich, *Quantum Optics in Phase Space* (Wiley-VCH, Berlin, 2001).
  - [21] The atomic system could be a two-level atom or an effective two-level system with an auxiliary level ( $\Lambda$  system).
  - [22] T. D. Ladd, P. van Loock, K. Nemoto, W. J. Munro, and Y. Yamamoto, *New J. Phys.* **8**, 184 (2006).
  - [23] X. Wang and P. Zanardi, *Phys. Rev. A* **65**, 032327 (2002).
  - [24] The qubus mode can be prepared in an arbitrary state, which could even be mixed. However, the qubus should not evolve independently on time scales comparable with that of the gate, for example, by decoherence.
  - [25] The sign change here can be realized by a simple bit flip on the matter qubit.
  - [26] The sequence of operations  $U(\epsilon, \chi\sigma_z)$ ,  $U(\epsilon, -\chi\sigma_z)$ ,  $U(-\epsilon, -\chi\sigma_z)$ ,  $U(-\epsilon, \chi\sigma_z)$  would achieve the controlled displacement alone.
  - [27] H. Jeong, *Phys. Rev. A* **73**, 052320 (2006).