

# Observation of the Faraday effect via beam deflection in a longitudinal magnetic field

Ambarish Ghosh, Winfield Hill, and Peer Fischer\*

The Rowland Institute at Harvard, Harvard University, Cambridge, Massachusetts 02142, USA

(Received 8 February 2007; revised manuscript received 13 September 2007; published 6 November 2007)

We show that magnetic-field-induced circular differential deflection of light can be observed in reflection or refraction at a single interface. The difference in the reflection or refraction angles between the two circular polarization components is a function of the magnetic-field strength and the Verdet constant, and permits the observation of the Faraday effect not via polarization rotation in transmission, but via changes in the propagation direction. Deflection measurements do not suffer from  $n-\pi$  ambiguities and are shown to be another means to map magnetic fields with high axial resolution, or to determine the sign and magnitude of magnetic-field pulses in a single measurement.

DOI: [10.1103/PhysRevA.76.055402](https://doi.org/10.1103/PhysRevA.76.055402)

PACS number(s): 33.55.Ad, 33.55.Fi, 78.20.Ls, 78.20.Ek

Well established magneto-optical phenomena are the Faraday, Cotton-Mouton-Voigt, and the magneto-optical Kerr (MOKE) effects, as well as magnetic circular dichroism. These are described by changes in the azimuth (optical rotation) or the ellipticity of an electromagnetic wave. Apart from changes in these Stokes parameters, a magnetic field may also influence the propagation direction of light.

The deflection of a light beam in isotropic media subject to a homogeneous [1] *transverse* magnetic field has been reported by Rikken and van Tiggelen who observed the deflection in scattering [2] as well as in transmission [3], and by Blasberg and Suter [4] who showed that angular momentum conservation causes a small lateral displacement near resonance in an atomic vapor. Transverse magnetic-field-induced refraction at the cesium-vapor-glass interface has been reported by Schlessler and Weis [5]. Their observed deflection appears to be nonlinear in the strength of the magnetic field and the light intensity [5], and a complete explanation for this effect has not yet been provided [3,5].

It is expected that magneto-optical activity associated with a *longitudinal* magnetic field not only manifests itself through Faraday rotation in transmission, but also as a deflection of the light beam in reflection and in refraction at an interface [6]. The two circularly polarized components of a light wave experience different angles of reflection and/or refraction at the interface of a Faraday medium. It follows that a linearly polarized light beam will separate into its circular components at such an interface [6–8], and Brace was able to resolve the two circular components after  $\sim 20$  reflections inside a double prism (containing a  $\lambda/2$  plate) placed inside a magnet [6]. Here, we show that it is possible to measure deflections at a single interface in the presence of a longitudinal magnetic field both in reflection and in refraction. The magnetic-field-induced beam deflection is observed using position sensitive detection schemes and is shown to be an alternate means to determine either Verdet constants or to obtain the magnitude and sign of a varying magnetic field in a “single-shot” measurement. The longitudinal component of a magnetic field may be determined with high axial and temporal resolution.

A magnetic field renders any medium (isotropic or oriented) optically active. In particular, any isotropic medium becomes uniaxial in the presence of a magnetic field, and its refractive indices for right-(+) and left-(−) circularly polarized light are unequal, such that the plane of polarization of a linearly polarized electromagnetic wave rotates as the wave propagates along the direction of the field. The Faraday rotation in radians developed by an electromagnetic wave at the wavelength  $\lambda$  traversing a distance  $l$  is given by

$$\alpha = VBl = \frac{\pi l}{\lambda}(n^{(-)} - n^{(+)}), \quad (1)$$

where  $V$  is the frequency-dependent Verdet constant and  $B$  is the magnetic field strength.

If one considers the refraction of an electromagnetic wave at a boundary formed by a Faraday medium and a medium with a negligible Verdet constant, as shown in Fig. 1(a), then

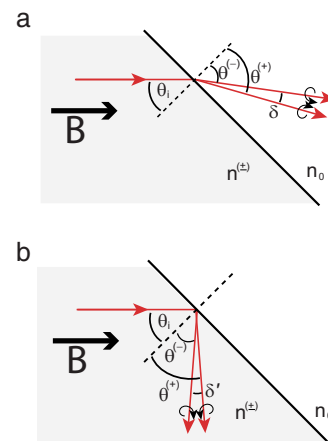

FIG. 1. (Color online) (a) Double refraction at the boundary of a Faraday medium (shaded) and a medium with negligible Verdet constant characterized by the scalar refractive index  $n_0$ . The direction of the transmitted beam is different for left- and right-circularly polarized waves. An unpolarized or a linearly polarized beam will thus split into two. (b) Reflection inside a Faraday medium. The incident beam is subject to circular birefringence  $n^{(\pm)}$  such that the left- and right-circular components have different angles of reflection [6].

\*fischer@rowland.harvard.edu

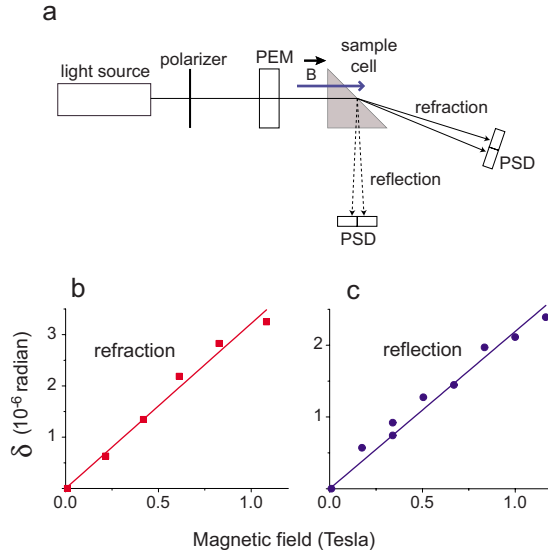

FIG. 2. (Color online) (a) Schematic of the experimental arrangement. Light passes through a photoelastic modulator (PEM) where its polarization is switched between left and right circular at 47 kHz before refracting in a glass prism (solid arrow), or reflecting inside a liquid cuvette (dotted arrow). The prism and the prismatic cuvette are respectively mounted inside an electromagnet (not shown). The position of the beam is recorded with a position sensitive detector (PSD). (b) Refraction data for SF11 glass at 532 nm. (c) Reflection data for pure CS<sub>2</sub> at 473 nm.

the left- and right-circularly polarized waves or wave components must independently obey Snell’s law. Circularly polarized waves that propagate along the optical axis in the Faraday medium will thus refract into the medium characterized by the polarization independent refractive index  $n_0$  with angles of refraction  $\theta^{(-)}$  and  $\theta^{(+)}$ , depending on whether they are, respectively, left- or right-circularly polarized. Similarly, if an unpolarized or linearly polarized wave is incident from the Faraday medium with angle of incidence  $\theta_i$ , then it will split into two beams, one left- and the other right-circularly polarized. The angular divergence  $\delta = \theta^{(+)} - \theta^{(-)}$  between the two refracted circular polarization components in Fig. 1(a) is

$$\delta \approx \frac{(n^{(+)} - n^{(-)}) \sin \theta_i}{n_0 \cos \theta}, \quad (2)$$

where  $\theta$  is the average of the two angles of refraction. It follows that  $B$ -field-induced deflection of light at an interface can be used to determine circular birefringences, and hence Verdet constants, or in the case of a known Verdet constant the strength of an applied magnetic field:

$$\delta \approx - \frac{\lambda \sin \theta_i}{\pi n_0 \cos \theta} VB. \quad (3)$$

One may similarly consider the components of an electromagnetic wave that reflects inside the Faraday medium. Because a circularly polarized wave reverses its circularity upon reflection, the incident and the reflected waves are necessarily associated with different refractive indices. Hence, in an optically active medium, the angle of reflection of a

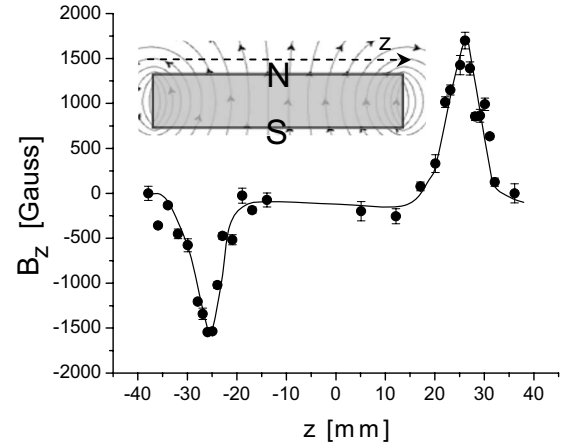

FIG. 3. Single interface refraction in a SF11 glass prism is used to determine the axial (tangential) magnetic field  $\sim 2$  mm above a permanent magnet (along the dotted line as depicted in the inset), where  $10^4 G = 1$  T. The position is relative to the center of the magnet and is determined along the  $+z$  direction using a 633 nm HeNe laser. The solid line is to guide the eye.

circularly polarized wave will in general not equal the angle of incidence [6,9]. An unpolarized or linearly polarized wave can therefore split into its two circularly polarized components upon reflection [6]. The theoretical description of magnetic double reflection is complicated by the fact that the reflected wave no longer propagates along the optic axis of the system. The reflected beam is thus potentially subject to circular birefringence (Faraday effect) as well as the birefringence due to a transverse magnetic field. To simplify the discussion we will consider a reflected beam that propagates in a direction perpendicular to the magnetic field as shown in Fig. 1(b), such that it experiences no birefringence due to the longitudinal component of the magnetic field. Furthermore, we neglect any transverse  $B$ -field-induced birefringence [3] and assume that the reflected waves are only subject to an

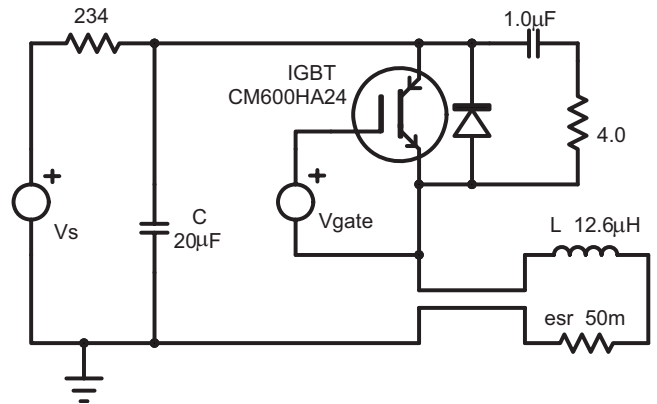

FIG. 4. Pulse source capable of 1.2 kV and 1.5 kA, with  $C$ , a pulse capacitor (two Maxwell No. 30545),  $L$  (a coil made with no. 8 litz wire), and a 1.2 kV insulated gate bipolar transistor (IGBT) switch (Powerex). The total loss resistance is less than  $0.05 \Omega$  [13]. A resistor protects the HV power supply from the 2 kV swing of capacitor  $C$ , and an RC snubber protects the IGBT from a flyback pulse due to the reverse-recovery time of the IGBT’s antiparallel diode.

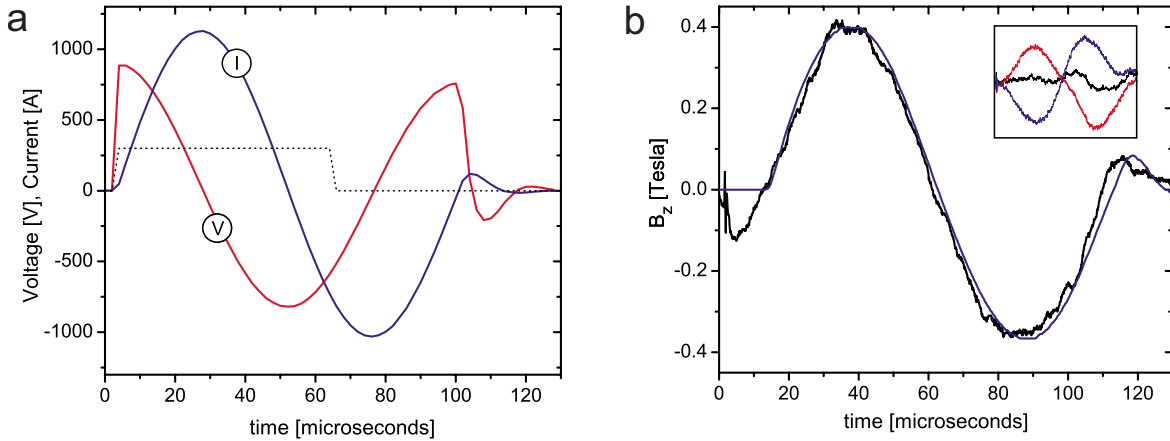

FIG. 5. (Color online) (a) Voltage (V) and current (I) into the coil for  $V_S=900\text{V}$  from a simulation of the circuit. The timing of the IGBT gate pulse is indicated by the dotted line (black; no scale indicated). (b) Deflection of a circularly polarized beam as detected on a PSD, filtered (1 kHz high pass and 30 kHz low pass), and recorded on an oscilloscope (black trace is raw data, i.e., no background correction or signal averaging). The solid blue line is the measured current (no scale indicated). The inset shows the opposite deflections for the two circular polarization states (red and blue) and the linearly polarized laser beam (trace at center in black) all measured at a different location in the solenoid. The large currents and fields in the coil give rise to magnetostriction and observable electrical interferences.

average refractive index  $n=(n^{(-)}+n^{(+)})/2$ . The angular divergence  $\delta'$  after a single reflection is

$$\delta' \approx -\frac{\lambda \tan \theta_i}{\pi n} VB. \quad (4)$$

Depending on the Fresnel reflection coefficients for a given interface, the circular components may not fully reverse their circularity upon reflection and become elliptically polarized. This can be accounted for by including the appropriate Fresnel coefficients.

The magnetic-field-induced double refraction and reflection phenomena can be observed at a single interface using position sensitive detection as schematically depicted in Fig. 2(a). In the refraction measurements light from a 532 nm diode laser was modulated between left and right circular with a Hinds photoelastic modulator (PEM) at 47 kHz and then passed through a transparent glass (SF11) prism mounted between the pole pieces of an electromagnet (Walker HV7). The position of the laser beam was recorded with a (SL5-1, UDT Sensors) position sensitive diode and a lock-in amplifier. The difference in the angles of refraction for the two circular polarization components as a function of the applied magnetic field strength is shown in Fig. 2(b). From a linear fit to the data and using Eq. (3), a Verdet constant of  $29.37 \pm 0.96 \text{ rad T}^{-1} \text{ m}^{-1}$  is obtained. This is in good agreement with the tabulated values of the Verdet constant for SF11 Schott glass [10], from which we interpolate a Verdet constant of  $30.44 \text{ rad T}^{-1} \text{ m}^{-1}$ . Each data point in Fig. 2(b) is measured with an uncertainty that is approximately the size of the symbol. However, the photoelastic modulator itself gives rise to an angular deviation that fluctuates on the time scale of the measurement and causes the data points to deviate from a straight line. The goodness of the straight-line fit is thus a more appropriate measure of the experimental error.

The circular differential reflection in a longitudinal mag-

netic field was observed in a right-angle prismatic cuvette filled with carbon disulfide ( $\text{CS}_2$ ). A mirror was mounted parallel to the hypotenuse on the inside of the liquid cuvette. The polarization modulated beam from a 473 nm diode pumped solid state laser traveled along the direction of the magnetic field in the liquid and upon reflection exited the liquid perpendicular to the magnetic field and normal to the window of the cuvette. From the detected angular divergence shown in Fig. 2(c) we deduce a Verdet constant of  $23.7 \pm 0.8 \text{ rad T}^{-1} \text{ m}^{-1}$ . We suspect that the small difference with the reported constant of  $0.0694 \text{ min G}^{-1} \text{ cm}^{-1}$  ( $20.2 \text{ rad T}^{-1} \text{ m}^{-1}$ ) at 476.5 nm [11] is due to ellipticity in the reflected beam, which has not been accounted for. We stress that even though the experimental geometry is chosen such that the medium is (approximately) uniaxial, the effects described here will in general be exhibited by any wave that refracts or reflects at the interface of a Faraday medium. Similar deflection phenomena should be observable in diffraction [12].

Measurements of beam deflection in a longitudinal magnetic field are expected to find a number of uses. For instance, unlike Faraday rotation, which is a function of the light path through the medium, magneto-optical double refraction arises within a few wavelengths at the interface. It is thus possible to optically map axial magnetic fields. To demonstrate this, we scanned the SF11 prism [used in Fig. 2(b)]  $\sim 2 \text{ mm}$  above the surface of a permanent rare earth magnet. As shown in Fig. 3, this technique permits the tangential magnetic-field component to be determined. The lateral resolution is given by the beam diameter of the laser, here 1 mm, while the axial resolution was  $< 1 \text{ mm}$ . The deflections (sensitivity) can be much larger in glasses with large Verdet constants.

Another potentially useful property of the deflection phenomena is that the sign and magnitude of a magnetic-field pulse may be determined simultaneously in a single measurement, since the direction of the deflection may be posi-

tive or negative depending on the polarity of the magnetic-field pulse. Furthermore, deflections do not suffer from the  $n$ - $\pi$  ambiguity, which can plague Faraday rotation measurements [14,15]. Deflection is thus particularly suited to the measurement of large magnetic-field pulses. We have used single interface refraction to measure the magnetic field inside a solenoid. A custom-built pulsed 1.8 MW power supply, as shown in Fig. 4(a), is used to generate 100 $\mu$ s single-cycle magnetic-field pulses. Experiments were conducted using a small 26 turn coil with a calculated peak field of  $\sim 0.53$ T. To record the pulse in real time, we continuously monitor the position of a circularly polarized beam on a position sensitive detector (SL5-1, UDT Sensors) placed  $\sim 1$  m away from the refracting surface. No polarization modulation is used. The output of the PSD is differentially amplified and bandpass filtered. The deflection is sensitive to the sign and magnitude of the pulse, as can be seen in Fig. 5(b). The magnetic field was measured on the axis of the coil and 14 mm away from the center of the  $\sim 38$ mm long solenoid. At this position the estimated field strength is 0.44T, which agrees well with the measured field strength of  $\sim 0.39 \pm 0.04$ T. Opposite circular polarization states deflect in opposite directions, as can be seen in the inset in Fig. 5(b).

Finally, we note that magnetic birefringence in a “Faraday wedge,” similar to that drawn in Fig. 1(a), has been proposed by Macquart and Melrose as a possible explanation for the circularly polarized radio emissions observed from pulsars and quasars [16]. That magnetic double refraction and reflection phenomena may not only be observed with polarized electromagnetic waves, but also with an unpolarized source, may also be of significance in other astrophysical observations.

In summary, we have shown that the Faraday effect can be observed via double refraction or reflection at a single interface in the presence of a longitudinal magnetic field. We have demonstrated that the difference in the propagation directions of the two refracted (or reflected) circular polarization components is an alternative means to determine Verdet constants or magnetic-field strengths. Magnetic-field components in the direction of the refracting or reflecting light beam may be determined with good axial resolution.

We thank Bryan Gaensler for helpful comments and for drawing our attention to Ref. [16]. Funding by the Rowland Institute is gratefully acknowledged.

- 
- [1] A light beam may also deflect due to a variation in the index of refraction as a result of a magnetic field gradient: R. Holzner *et al.*, Phys. Rev. Lett. **78**, 3451 (1997).
- [2] G. L. J. A. Rikken and B. A. van Tiggelen, Nature (London) **381**, 54 (1996).
- [3] G. L. J. A. Rikken and B. A. van Tiggelen, Phys. Rev. Lett. **78**, 847 (1997).
- [4] T. Blasberg and D. Suter, Phys. Rev. Lett. **69**, 2507 (1992).
- [5] R. Schlessler and A. Weis, Opt. Lett. **17**, 1015 (1992).
- [6] D. B. Brace, Philos. Mag. **1**, 464 (1901).
- [7] R. B. Wood, *Physical Optics* (Macmillan, New York, 1988).
- [8] M. Silverman and R. Sohn, Am. J. Phys. **54**, 69 (1986).
- [9] A. Ghosh and P. Fischer, Phys. Rev. Lett. **97**, 173002 (2006).
- [10] *Optical Glass Catalog* (Schott-Glass, Mainz, Germany, 1985). Verdet constant of SF11 glass: 18.3, 23.6, 28.5, and 49.5 rad T<sup>-1</sup> m<sup>-1</sup>, at respectively, 656.3, 589.3, 546.1, and 439.5 nm.
- [11] A. B. Villaverde and D. A. Donatti, J. Chem. Phys. **71**, 4021 (1979).
- [12] A. Ghosh, F. M. Fazal, and P. Fischer, Opt. Lett. **32**, 1836 (2007).
- [13] The peak current is given by  $I_p = kV\sqrt{C/L}$ , where the loss term  $k = e^{-\pi/4Q}$  and  $Q = \omega L/R$  for the effective series resistance  $R$ .
- [14] M. Tatarakis *et al.*, Nature (London) **415**, 280 (2002).
- [15] In radio astronomy the  $n$ - $\pi$  ambiguity may be overcome with correlation techniques; see, for instance, B. M. Gaensler *et al.*, Astrophys. J. **549**, 959 (2001).
- [16] J.-P. Macquart and D. B. Melrose, Astrophys. J. **545**, 798 (2000).