

## Fast SWAP gate by adiabatic passage

N. Sangouard,\* X. Lacour, S. Guérin, and H. R. Jauslin

*Laboratoire de Physique, Université de Bourgogne, UMR CNRS 5027, BP 47870, 21078 Dijon Cedex, France*

(Received 26 January 2005; revised manuscript received 20 May 2005; published 6 December 2005)

We present a process for the construction of a SWAP gate which does not require a composition of elementary gates from a universal set. We propose to employ direct techniques adapted to the preparation of this specific gate. The mechanism, based on adiabatic passage, constitutes a decoherence-free method in the sense that spontaneous emission and cavity damping are avoided.

DOI: [10.1103/PhysRevA.72.062309](https://doi.org/10.1103/PhysRevA.72.062309)

PACS number(s): 03.67.Lx, 32.80.Qk

### I. INTRODUCTION

The perspective of a high computational power generates intense efforts to build quantum computers. The quantum logical gates, which are one of the essential building blocks of a quantum computer, have received a lot of attention. They act on qubits, whose states ideally should be insensitive to decoherence, easily prepared and measured. Moreover, the construction of logical gates requires a robust mechanism with respect to fluctuations of experimental parameters. The usual approach consists in creating a set of universal gates [1] such that all logical quantum gates can, in principle, be obtained from the composition of gates belonging to this set. The universal sets  $\{U_2\}$  [2] and  $\{U_1, \text{CNOT}\}$  [3] where  $U_N$  is a general unitary matrix in  $SU(2^N)$  have played a central role in quantum computation. However, this generic construction usually requires compositions of many elementary gates. This entails an accumulation of decoherence and of other detrimental effects, which become a considerable obstacle for a practical implementation.

In this paper, we propose a technique to build a fast SWAP gate obtained by a scheme based on adiabatic passage with an optical cavity. It does not use the composition of gates but aims instead at the construction of a specific gate in such a way that losses and decoherence effects remain as small as possible. This direct method is faster, i.e., it involves considerably fewer individual steps than the composition of elementary gates build independently. It is thus less exposed to losses and decoherence processes.

We chose a representation of qubits by atomic states driven by adiabatic fields in a configuration that is particularly insensitive to decoherence. Indeed, the decoherence due to spontaneous emission can be avoided if the dynamics follows a dark state, i.e., a state without components on lossy excited states. Moreover, the adiabatic principles provide the robustness of the method with respect to partial knowledge of the model and against small variations of field parameters. To implement the gates in a robust manner, one has to control precisely the parameters that determine the action of the gates. We therefore do not use dynamical phases, requiring controllable field amplitudes, nor geometrical phases, requiring a controllable loop in the parameter space [4–7]. We use

instead static phase differences of lasers, which can be easily controlled experimentally.

In this context of atomic qubits manipulated by adiabatic laser fields, a mechanism has been proposed in Ref. [8] to implement by four pulses all one-qubit gates, i.e., a general unitary matrix  $U_1$  in  $SU(2)$  in a tripod system [4,5]. In Ref. [9], five-level atoms are fixed in a single-mode optical cavity and are addressed individually by a set of laser pulses [10]. The authors proposed sequences of seven pulses to build a two-qubit controlled-phase gate [C-phase( $\theta$ )] and a two-qubit controlled-NOT gate (CNOT). The configuration of the five-level atoms is defined by adding a second excited state to the tripod system [see Fig. 2(a)]. Since in the tripod, all one-qubit gates can be constructed [8], one thus has a mechanism to implement the universal set  $\{U_1, \text{C-phase}(\theta)\}$  [11] from which all quantum gates can be deduced. For instance, the SWAP gate, which interchanges the values of two qubits, requires three CNOT gates [12], or can be decomposed into six *Hadamard* gates and three C-phase( $\pi$ ) gates (see Fig. 1), which corresponds to at least 21 pulses in this system.

Since in the experimental implementation of each gate there are always losses, due to uncontrolled interactions or decoherence, it is useful to design direct implementations of specific gates instead of relegating them to a superposition of many elementary gates.

### II. SYSTEM

We propose an alternative mechanism based on adiabatic passage along dark states for the construction of the SWAP gate, which compared to the composition into C-phase and Hadamard gates, or into CNOT gates of Ref. [9], has the advantage to involve a much smaller number of pulses and thus to operate in a shorter time. This mechanism is

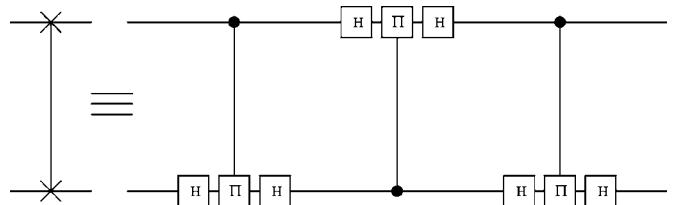

FIG. 1. Decomposition of the SWAP gate from C-phase( $\pi$ ) gates and Hadamard (H) gates on the two qubits.

\*Electronic address: [nicolas.sangouard@u-bourgogne.fr](mailto:nicolas.sangouard@u-bourgogne.fr)

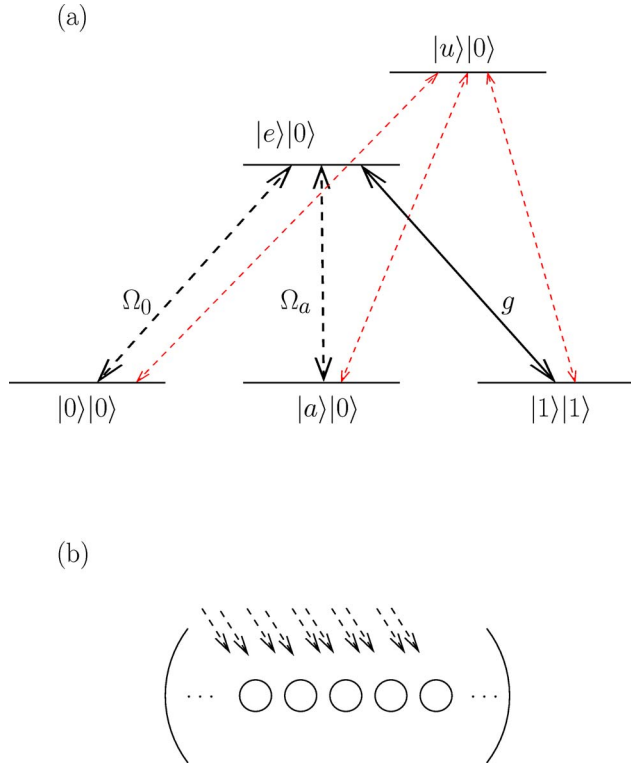

FIG. 2. (Color online) (a) Schematic representation of the five-level atom. Arrows show the laser (full arrows) and cavity (dashed arrows) couplings to perform the swap gate (thick arrows) and the general one qubit gate (thin arrows). (b) Representation of the atomic register trapped in a single-mode optical cavity. The atoms are represented by circles, the laser fields by dashed arrows.

decoherence-free in the sense that, in the adiabatic limit and under the condition of a cavity Rabi frequency much larger than the laser Rabi frequency, the excited atomic states and the cavity mode are not populated during the dynamics. We emphasize that the goal here is not to create an alternative universal set of gates offering the possibility to construct an arbitrary gate, but to prepare specific logical quantum gates in a fast way.

We assume that the atoms are fixed inside an optical cavity [Fig. 2(b)]. The proposed mechanism is implemented in the five-level extension of the tripod-type system in which the universal gate of Refs. [8,9] can be implemented [Fig. 2(a)].

We will use a notation, e.g., in Figs. 2 and 3, involving two kets: the left one labels the state of the atoms (a single or a pair) and the right one the photon number of the cavity field. The three ground states (for instance Zeeman levels)  $|0\rangle|0\rangle$ ,  $|a\rangle|0\rangle$ , and  $|1\rangle|1\rangle$  are coupled to the excited state  $|e\rangle|0\rangle$ , respectively, by two lasers associated to the Rabi frequencies  $\Omega_0$  and  $\Omega_a$ , and by a single mode cavity associated to the Rabi frequency  $g$ . The upper state  $|u\rangle$  is only used to implement a general one-qubit gate. We assume that the polarizations and the frequencies are such that each field drives a unique transition by a one-photon resonant process. As a consequence, the Stark shifts, which would add detrimental phases, can be neglected here. (Some estimates are presented below.) The atomic states  $|0\rangle$  and  $|1\rangle$  represent the computa-

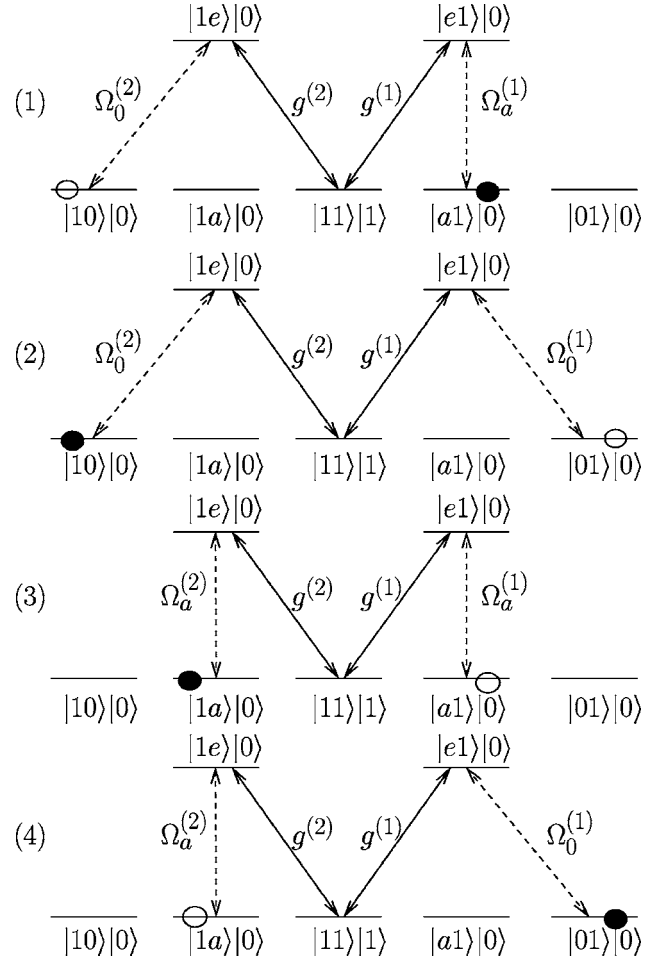

FIG. 3. Schematic representation of the four steps of the construction of the SWAP gate. For each step, the initial state is represented by an empty circle, whereas the final state is symbolized by a full black circle.

tional states of the qubit. The ancillary state  $|a\rangle$  will be used for the swap operation. The atomic register is fixed in the single-mode optical cavity [see Figs. 2(a) and 2(b)]. Each atom (labelled by  $k$ ) of the register is driven by a set of two pulsed laser fields  $[\Omega_0^{(k)}(t)$  and  $\Omega_a^{(k)}(t)]$  and by the cavity mode  $g^{(k)}$  which is time independent.

### III. MECHANISM

We propose a mechanism to prepare a SWAP gate with the help of a simple interaction scheme. The SWAP gate acts on two qubits as follows. The initial state  $|\psi_i\rangle$  of the atoms in the cavity, before interaction with the lasers, is defined as

$$|\psi_i\rangle = \alpha|00\rangle|0\rangle + \beta|01\rangle|0\rangle + \gamma|10\rangle|0\rangle + \delta|11\rangle|0\rangle, \quad (1)$$

where the indices  $s_1, s_2$  of the states of the form  $|s_1 s_2\rangle|0\rangle$  denote, respectively, the state of the first and second atom, and  $|0\rangle$  is the initial vacuum state of the cavity-mode field.  $\alpha, \beta, \gamma, \delta$  are complex coefficients. The swap gate exchanges the values of the two qubits leading to the output state

$$|\psi_0\rangle = \alpha|00\rangle|0\rangle + \gamma|01\rangle|0\rangle + \beta|10\rangle|0\rangle + \delta|11\rangle|0\rangle. \quad (2)$$

The main idea to construct this gate is represented in Fig. 3. It consists of exchanging the values of the qubits by the use of an ancillary ground state. Adiabatic passage along dark states (i.e., with no components in the atomic excited states and a negligible component in the excited cavity states) will be used.

The four steps can be summarized as follows:

(1) The population of  $|10\rangle|0\rangle$  is completely transferred into  $|a1\rangle|0\rangle$  by the use of two resonant pulses  $\Omega_a^{(1)}$ ,  $\Omega_0^{(2)}$  switched on and off in a counterintuitive pulse sequence [i.e.,  $\Omega_a^{(1)}$  before  $\Omega_0^{(2)}$ ]. After the interaction, the state becomes

$$|\psi_1\rangle = \alpha|00\rangle|0\rangle + \beta|01\rangle|0\rangle + \gamma|a1\rangle|0\rangle + \delta|11\rangle|0\rangle. \quad (3)$$

(2) With a similar technique, the population of  $|01\rangle|0\rangle$  is transferred into  $|10\rangle|0\rangle$  by the use of the counterintuitive sequence of two pulses  $\Omega_0^{(2)}$ ,  $\Omega_a^{(1)}$  leading to the state

$$|\psi_2\rangle = \alpha|00\rangle|0\rangle + \gamma|a1\rangle|0\rangle + \beta|10\rangle|0\rangle + \delta|11\rangle|0\rangle. \quad (4)$$

(3) The population of  $|a1\rangle|0\rangle$  is transferred into  $|1a\rangle|0\rangle$  by the use of the sequence  $\Omega_a^{(2)}$ ,  $\Omega_a^{(1)}$  giving

$$|\psi_3\rangle = \alpha|00\rangle|0\rangle + \gamma|1a\rangle|0\rangle + \beta|10\rangle|0\rangle + \delta|11\rangle|0\rangle. \quad (5)$$

(4) The population of  $|1a\rangle|0\rangle$  is transferred into  $|01\rangle|0\rangle$  by the use of the sequence  $\Omega_0^{(1)}$ ,  $\Omega_a^{(2)}$ . As a result, the system is in the state

$$|\psi_4\rangle = \alpha|00\rangle|0\rangle + \gamma|01\rangle|0\rangle + \beta|10\rangle|0\rangle + \delta|11\rangle|0\rangle, \quad (6)$$

which coincides with the output state of the SWAP gate.

In what follows, we give the instantaneous eigenvectors connected with the initial condition and that are thus adiabatically followed by the dynamics for the four steps. We show that they are associated with dark states with no component in the atomic excited states and a negligible component in the excited cavity states.

Since the lasers do not couple the atomic state  $|1\rangle$ , the state  $|11\rangle|0\rangle$  of the initial condition (1) is decoupled from the other ones. The other states of (1) are connected to two orthogonal decoupled subspaces denoted  $\mathcal{H}_7$  and  $\mathcal{H}_{16}$  of dimension 7 and 16, respectively. For each step, one ground state  $|0\rangle$  or  $|a\rangle$  of each atom is coupled by a laser field to the excited state, and the other one is not coupled to the excited state. To summarize the calculation of the instantaneous eigenstates for the four steps, we introduce the following notation: the state coupled by a laser field is labeled  $|L^{(i)}\rangle$  ( $|0^{(i)}\rangle$  or  $|a^{(i)}\rangle$ ) and the noncoupled state  $|N^{(i)}\rangle$  ( $|a^{(i)}\rangle$  or  $|0^{(i)}\rangle$ ). The index  $i=1, 2$  labels the atom  $i$ . The instantaneous eigenstates in each subspace  $\mathcal{H}_7$  and  $\mathcal{H}_{16}$  can be characterized as follows: in  $\mathcal{H}_7$ , the states  $|N^{(1)}1\rangle|0\rangle$  and  $|1N^{(2)}\rangle|0\rangle$  are not coupled by the lasers and thus do not participate to the dynamics. Only the atomic dark state (i.e., without component in the excited atomic states) [10],

$$|\phi_7\rangle \propto g^{(1)}\Omega^{(2)}|L^{(1)}1\rangle|0\rangle + g^{(2)}\Omega^{(1)}|1L^{(2)}\rangle|0\rangle - \Omega^{(1)}\Omega^{(2)}|11\rangle|1\rangle, \quad (7)$$

(where the normalization coefficient has been omitted) participates in the dynamics. The first step, associated with

$L^{(1)} \equiv a$ ,  $L^{(2)} \equiv 0$ ,  $\Omega^{(1)} \equiv \Omega_a^{(1)}$ ,  $\Omega^{(2)} \equiv \Omega_0^{(2)}$  leads to the initial and final connections symbolically written as  $|10\rangle|0\rangle \rightarrow |\phi_7\rangle \rightarrow |a1\rangle|0\rangle$  (see Fig. 3). The second, third, and fourth steps give, respectively, the connections  $|01\rangle|0\rangle \rightarrow |\phi_7\rangle \rightarrow |10\rangle|0\rangle$ ,  $|a1\rangle|0\rangle \rightarrow |\phi_7\rangle \rightarrow |1a\rangle|0\rangle$ , and  $|1a\rangle|0\rangle \rightarrow |\phi_7\rangle \rightarrow |01\rangle|0\rangle$ . We determine four atomic dark states in the subspace  $\mathcal{H}_{16}$  connected to the state  $|00\rangle|0\rangle$  of the initial condition (1),

$$|\phi_{16(1)}\rangle \propto \Omega^{(2)}|N^{(1)}1\rangle|1\rangle - g^{(2)}|N^{(1)}L^{(2)}\rangle|0\rangle, \quad (8a)$$

$$|\phi_{16(2)}\rangle \propto g^{(1)}g^{(2)}\sqrt{2}|L^{(1)}L^{(2)}\rangle|0\rangle - g^{(2)}\Omega^{(1)}\sqrt{2}|1L^{(2)}\rangle|1\rangle - g^{(1)}\Omega^{(2)}\sqrt{2}|L^{(1)}1\rangle|1\rangle + \Omega^{(1)}\Omega^{(2)}|11\rangle|2\rangle, \quad (8b)$$

$$|\phi_{16(3)}\rangle = |N^{(1)}N^{(2)}\rangle|0\rangle, \quad (8c)$$

$$|\phi_{16(4)}\rangle \propto \Omega^{(1)}|1N^{(2)}\rangle|1\rangle - g^{(1)}|L^{(1)}N^{(2)}\rangle|0\rangle. \quad (8d)$$

The state  $|00\rangle|0\rangle$  is connected initially and finally to the dark state  $|\phi_{16(n)}\rangle$  at the  $n$ th step. The phase term of the final state is equal to one: (i) the optical phase is null since the populated atomic states are degenerate, (ii) the dynamical phase is reduced to zero since the eigenvalues associated to each dark state are null, and (iii) the geometric phase is equal to zero. Indeed, at every time ( $\langle\phi'_d(s)|d/ds|\phi_d(s)\rangle=0$   $|\phi'_d(s)\rangle$  and  $|\phi_d(s)\rangle$  being two different or identical dark eigenstates) since for  $|\phi'_d(s)\rangle=|\phi_d(s)\rangle$ , the phase of the lasers is constant during each step and for  $|\phi'_d(s)\rangle \neq |\phi_d(s)\rangle$ , the dark states belong to orthogonal subspaces.

Since the dynamics follows atomic dark states, the excited atomic state is never populated (in the adiabatic limit). Moreover, the projections of the dark states into the excited cavity photon states can be made negligible if  $g^{(i)} \gg \Omega^{(i)}$  [15]. In this case, the mechanism we propose is a decoherence-free method in the sense that the process is not sensitive to spontaneous emission from the atomic excited states and to the lifetime of photons in the optical cavity.

We present the numerical validation of the mechanism proposed for the construction of the SWAP gate. We show in Fig. 4, the time evolution of four initial states: in (a) and (d) the population of the initial states  $|00\rangle|0\rangle$  and  $|11\rangle|0\rangle$ , respectively, stays in these states after the interaction with the eight pulses, in (b) and (c) the population of the initial states  $|01\rangle|0\rangle$  and  $|10\rangle|0\rangle$  are exchanged. In (e), we show the Rabi frequencies associated to each pulse. The laser Rabi frequencies are all chosen of the form  $\Omega(t) = \Omega_{\max} e^{-(t/T_p)^2}$ . Since the four steps of the mechanism can be seen as double-STIRAPs [13,14], each STIRAP involving one laser and the cavity, the amplitudes of the coupling must satisfy  $\Omega_{\max} T_p, g T_p \gg 1$  to fulfill the adiabatic conditions. The delay between two pulses of the same step is chosen equal to  $2 \times 0.6 T_p$  to minimize the nonadiabatic losses [16]. Moreover, the condition  $g \gg \Omega_{\max}$  guarantees that the cavity mode is negligibly populated during the interaction with the pulses.

#### IV. DISCUSSION

We notice that the two identical pulses  $\Omega_0^{(2)}$  used successively in the first and second step can be replaced by a single

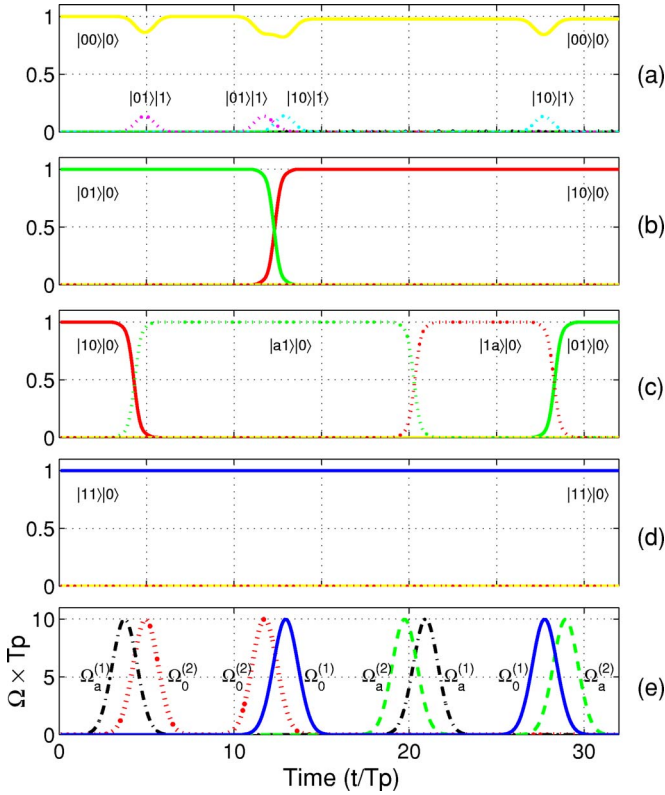

FIG. 4. (Color online) Numerical simulation exhibiting the populations for the initial conditions: (a)  $|00\rangle|0\rangle$ , (b)  $|01\rangle|0\rangle$ , (c)  $|10\rangle|0\rangle$ , and (d)  $|11\rangle|0\rangle$ . The states which are populated during the interaction with the pulses or between two steps are indicated. (e) Rabi frequencies. The parameters used are  $\Omega_{\max}T_p=10$ ,  $gT_p=25$ . The delay between two pulses of the same steps is  $1.2T_p$ .

pulse. The process we propose then requires the use of only seven adiabatic pulses.

As a realistic atomic level scheme, we consider the  $2^3S_1-2^3P_0$  transition in metastable helium, of linewidth  $\Gamma=10^7\text{ s}^{-1}$  (see for instance [17]). The Rabi frequencies are  $\Omega\sim 10^8\sqrt{I}\text{ s}^{-1}$  with the field intensities  $I$  in  $\text{W}/\text{cm}^2$ . We obtain beyond the resonant approximation using the polarizability an upper estimate for the Stark shifts (in absolute value) as  $S\sim 100I\text{ s}^{-1}$ . Taking into account the loss of the intermediate state requires  $(\Omega_{\max}T_p)^2\gg\Gamma T_p$  for adiabatic passage, which is satisfied for  $\Omega_{\max}T_p\gg 1$  and  $\Omega_{\max}\gg\Gamma$ . We use  $\Omega_{\max}T_p=10$  corresponding to, e.g.,  $I=10^4\text{ W}/\text{cm}^2$  and

$T_p=1\text{ ns}$ , which gives  $\Omega_{\max}\sim 10^{10}\text{ s}^{-1}$  and an estimate of the phases  $S_{\max}T_p\sim 10^{-3}\ll 2\pi$ . They can therefore be neglected.

The swap method we have presented can be extended to build a CNOT gate. The process is composed of six steps: We first transfer the population of the state  $|1\rangle$  of the second atom in the ancillary state  $|a\rangle$  by STIRAP using two additional resonant laser fields with the upper state  $|u\rangle$ . The next four steps allow us to interchange the populations of the states  $|10\rangle|0\rangle$  and  $|1a\rangle|0\rangle$  by a similar swap method like the one shown in this paper. The last step transfers back the population of the ancillary state  $|a\rangle$  of the second atom in state  $|1\rangle$ . The population transfers are realized by adiabatic passage along dark states. We thus obtain a direct and decoherence-free method for the creation of the CNOT gate that requires the use of 11 pulses. In comparison to the method proposed in Ref. [9], this technique does not use f-STIRAP (in which the ratio of two pulses has to be controlled [16]). A specific system (such as Zeeman states) is not necessarily required to guarantee the robustness of the technique.

## V. CONCLUSION

In conclusion, we have proposed to use a mechanism adapted to the construction of a specific gate instead of relying on compositions of a large number of elementary gates. We have illustrated this idea by the construction of a SWAP gate in a system where all one-qubit gates and the C-phase gate can be built. This technique requires the use of a cavity and seven pulses in a double-STIRAP configuration instead of 21 pulses when the SWAP gate is created from the composition of elementary gates. It is robust against variations of amplitude and duration of the pulses and of the delay between the pulses. Moreover, it constitutes a decoherence-free method in the sense that the excited states with short lifetimes are not populated and the cavity mode has no photon during the process. We conclude by noticing that this technique allows one to entangle the qubits on which it acts by manipulating the phase of the pulses. In this case, we get the composition of gates that could offer interesting possibilities to execute rapid quantum algorithms in which this composition is required.

Work is in progress to generalize this fast method to other gates. This requires other pulse sequences and involves different dark states.

[1] A. Galindo and M. A. Martin-Delgado, *Rev. Mod. Phys.* **74**, 347 (2002).  
 [2] D. P. DiVincenzo, *Phys. Rev. A* **51**, 1015 (1995).  
 [3] A. Barenco, C. H. Bennett, R. Cleve, D. P. DiVincenzo, N. Margolus, P. Shor, T. Sleator, J. A. Smolin, and H. Weinfurter, *Phys. Rev. A* **52**, 3457 (1995).  
 [4] R. Unanyan, M. Fleischhauer, B. W. Shore, and K. Bergmann, *Opt. Commun.* **155**, 144 (1998).  
 [5] R. G. Unanyan, B. W. Shore, and K. Bergmann, *Phys. Rev. A*

**59**, 2910 (1999).  
 [6] L.-M. Duan, J. I. Cirac, and P. Zoller, *Science* **292**, 1695 (2001).  
 [7] R. G. Unanyan and M. Fleischhauer, *Phys. Rev. A* **69**, 050302(R) (2004).  
 [8] Z. Kis and F. Renzoni, *Phys. Rev. A* **65**, 032318 (2002).  
 [9] H. Goto and K. Ichimura, *Phys. Rev. A* **70**, 012305 (2004).  
 [10] T. Pellizzari, S. A. Gardiner, J. I. Cirac, and P. Zoller, *Phys.*

- Rev. Lett. **75**, 3788 (1995).
- [11] The set  $\{U_1, \text{CNOT}\}$  is a universal set and the CNOT gate can be obtained by the composition of two Hadamard gates and one C-phase( $\pi$ ) gate.
- [12] F. Vatan and C. Williams, Phys. Rev. A **69**, 032315 (2004).
- [13] U. Gaubatz, P. Rudecki, S. Schiemann, and K. Bergmann, J. Chem. Phys. **92**, 5363 (1990).
- [14] K. Bergmann, H. Teuer, and B. W. Shore, Rev. Mod. Phys. **70**, 1003 (1998).
- [15] V. S. Malinovsky and D. J. Tannor, Phys. Rev. A **56**, 4929 (1997); N. V. Vitanov, *ibid.* **58**, 2295 (1998); A. M. Steane and D. M. Lucas, Fortschr. Phys. **48**, 839 (2000).
- [16] N. V. Vitanov, K. A. Suominen, and B. W. Shore, J. Phys. B **32**, 4535 (1999).
- [17] J. Lawall and M. Prentiss, Phys. Rev. Lett. **72**, 993 (1994).