

Quantum teleportation of an arbitrary superposition of atomic Dicke states

Tiegang Di,¹ Ashok Muthukrishnan,¹ Marlan O. Scully,^{1,2} and M. Suhail Zubairy¹

¹Department of Physics and Institute for Quantum Studies, Texas A&M University, Texas 77843, USA

²Departments of Chemistry and Aerospace & Mechanical Engineering, Princeton University, New Jersey 08544, USA

(Received 20 December 2004; revised manuscript received 18 February 2005; published 9 June 2005)

We propose a scheme for teleporting an arbitrary superposition of entangled Dicke states of any number of atoms (qubits) between two distant cavities. Our method relies on adiabatic passage using multi-atom dark states in each cavity, and a conditional detection of photons leaking out of both cavities. The ideal success probability of the protocol decreases polynomially in the number of atoms. The fidelity is unity for a single Dicke state, and can be optimized for the superposition by unitary postprocessing. Issues of experimental feasibility and applications to quantum informatics are discussed.

DOI: 10.1103/PhysRevA.71.062308

PACS number(s): 03.67.Lx, 42.50.Pq

I. INTRODUCTION

Quantum teleportation, first introduced by Bennett *et al.* in 1993 [1], has been of interest to the physics community for many years. It holds promise for many useful applications in quantum communication and quantum computing. It consists of three steps. The first step is to prepare an entangled pair of particles that is shared between sender (Alice) and receiver (Bob). The second step is a joint measurement by Alice of the unknown system and one particle of the entangled pair in a Bell basis. In the last step, a classical communication from Alice to Bob allows him to reconstruct the unknown state at his end following appropriate unitary transformations. This protocol has been verified experimentally for discrete [2], as well as continuous [3], systems.

In this paper, we consider a departure from the usual teleportation scenario in two ways. First, following an interesting recent suggestion [4], the entanglement resource necessary for teleportation is not introduced as shared particles between Alice and Bob, but rather comes about from a detection made by Alice of the joint state of both parties following independent preparation stages. Second, and central to the present paper, the state that is to be teleported is itself an arbitrary entangled state of many particles, constituting the most general transfer of quantum information between the two parties.

Usually atomic states are considered ideal for the storage of quantum information and are used as the stationary qubits. Earlier proposals for teleporting atomic states [5] used the atoms themselves as the carriers of quantum information (the “flying qubits”), and recently massive particle teleportation based on the Bennett *et al.* protocol was demonstrated by two groups using ions in a trap [6]. However, we note that photons have an intrinsic advantage in that they are better suited for communication over long distances. Cavity quantum electrodynamics methods offer an ideal coupling between atoms and photons in a controlled setting [7]. Based on such methods, we can achieve quantum teleportation of entangled states in multiple cavities [8], as well as arbitrary superpositions of Fock states in a single cavity [9].

In the present proposal, we take a different approach to scalable quantum teleportation. Some past studies have used the joint detection of photon decays to establish entangle-

ment among distant atoms [10,11]. In an application of this idea, Bose *et al.* [4] show how to teleport an atomic state from one cavity to another by conditional detection of a photon from both cavities. The main advantage of their scheme is the use of photon decays themselves to establish entanglement between the cavities, rather than the cumbersome task of coherently coupling a photon out of one cavity and feeding it into another cavity [12,13].

We consider the use of multi-atom dark states for quantum state transfer and teleportation, where the desired inter-cavity entanglement is brought about by a sequence of conditional detections of photons leaking out of both cavities. The main advantage of the proposed scheme is the ability to transfer multiqubit entangled states, namely, superpositions of atomic Dicke states [14], which can be engineered in a cavity by conditional detection methods, and have wide ranging applications in quantum information science (see [15]).

Our scheme is shown in Fig. 1. Alice and Bob have an equal number of (identical) atoms trapped inside their cavities, and the atoms are well separated so that any interaction between them can be neglected. The cavities are designed to be one sided so that the direction of cavity leakage is known, and photons leaking out of the cavities pass through a beam splitter (BS) and are detected by two 100 percent efficient detectors D_+ and D_- , which we treat using the quantum jump formalism [7,16].

In Sec. II, we discuss the two-atom case first, as it allows us to highlight the key physics that goes into making each

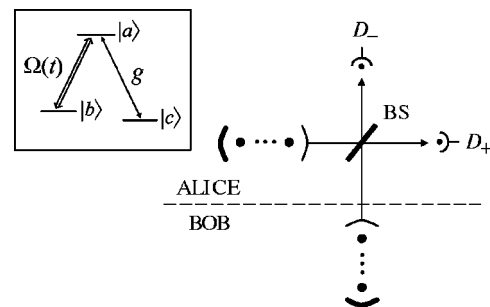

FIG. 1. Setup for teleporting an arbitrary superposition of atomic Dicke states. Inset shows the level configuration of each atom.

stage possible. We highlight the different control parameters that are unique to this protocol, and also briefly describe methods for unitary postprocessing of the teleported state to optimize the fidelity. In Sec. III, we show that the protocol can be generalized to an arbitrary number of atoms, and discuss the scaling of the success probability with the number of atoms. In Sec. IV, we discuss issues related to fidelity optimization and experimental feasibility of the protocol, and extensions to other quantum information applications.

II. TWO-ATOM TELEPORTATION

The atomic state in cavity A that Alice wants to teleport is assumed to be a (symmetric) Dicke-state superposition of the form

$$|\psi\rangle_A^{\text{in}} = C_0^I |cc\rangle_A + C_1^I \frac{|bc\rangle_A + |cb\rangle_A}{\sqrt{2}} + C_2^I |bb\rangle_A, \quad (1)$$

where $|a\rangle$, $|b\rangle$, and $|c\rangle$ are the states of each Λ -type three-level atom (see Fig. 1 inset). States $|cc\rangle$ and $|bb\rangle$ represent both atoms in the same state, and $(|bc\rangle + |cb\rangle)/\sqrt{2}$ is a state with one atom in state $|b\rangle$ and one in state $|c\rangle$. The coefficients C_0^I , C_1^I , and C_2^I are arbitrary and satisfy $|C_0^I|^2 + |C_1^I|^2 + |C_2^I|^2 = 1$.

Our protocol is based on a mapping of the two-atom state in Eq. (1) to an equivalent Fock-state superposition of the cavity field consisting of 0, 1, or 2 photons. This is done using multi-atom dressed state adiabatic passage in the cavity in the presence of a classical drive field, which has the ability to generate atom-field entanglement. However, we have to be careful because while the adiabatic passage is taking place, the photons can leak out and can be detected. Conditional detection of photons is necessary for our scheme because it leads to “quantum jumps” that enable the Dicke-state transfer. Thus, before proceeding, we examine the quantum jump formalism and how it applies in the multi-atom dark state picture.

In each cavity, the atoms are assumed to be simultaneously coupled to a time-dependent classical field, with Rabi frequency $\Omega(t)$, and a quantized cavity field mode with coupling strength g . The interaction is governed by the Hamiltonian [7], as

$$H = \hbar\Omega(t)(|a_1\rangle\langle b_1| + |b_1\rangle\langle a_1|) + \hbar g(|a_1\rangle\langle c_1|\hat{a} + |c_1\rangle\langle a_1|\hat{a}^\dagger) + (1 \rightarrow 2), \quad (2)$$

where 1 and 2 enumerate the atoms, and \hat{a}^\dagger and \hat{a} are photon creation and destruction operators, respectively. Now, conditional on the *absence* of a click in the detectors, the effective Hamiltonian governing the time evolution of the joint state is given by [17,18]

$$H_{\text{eff}} = H - i\kappa\hat{a}^\dagger\hat{a}. \quad (3)$$

Here, κ is the decay rate of the field mode \hat{a} , taken to be the same for both cavities. Note that H_{eff} is non-Hermitian due to the presence of the decay term. However, we can still define an effective “interaction picture,” where the atom-field evolution is described by the Hamiltonian

$$H_I = \exp(\kappa\hat{a}^\dagger\hat{a}t)H\exp(-\kappa\hat{a}^\dagger\hat{a}t), \quad (4)$$

and the corresponding state vector

$$|\Psi_I\rangle = \exp(\kappa\hat{a}^\dagger\hat{a}t)|\Psi\rangle. \quad (5)$$

In this way, by switching between pictures, we can treat the atom-field coupling separately from the decay of the field from the cavity. By numerically solving Schrödinger’s equation, we have verified that H_{eff} and H_I describe identical evolutions of the state in the respective pictures.

Finally, when detection events do occur, the quantum jump formalism associates these with the action of photon annihilation operators. For the two detectors D_\pm in our scheme (Fig. 1), we have the linear transformations due to the beam splitter:

$$\hat{D}_+ = (t\hat{a}_A + r\hat{a}_B), \quad (6)$$

$$\hat{D}_- = (r\hat{a}_A - t\hat{a}_B), \quad (7)$$

where \hat{a}_A (\hat{a}_B) is the destruction operator for the field in cavity A (B), and r and t are the (real) reflection and transmission coefficients for the beam splitter, such that $|r|^2 + |t|^2 = 1$.

A key to our approach is the use of multi-atom dark states in each cavity (see, for example, Ref. [19]). It is convenient to classify the states according to the total number of excitations present. For zero excitation, we have both atoms in state $|c\rangle$ and field in vacuum:

$$|\Psi_0^{\text{dark}}\rangle = |cc\rangle|0\rangle. \quad (8)$$

For one excitation, the manifold of states coupled by the Hamiltonian H (i.e., having nonzero matrix elements) are $|cc\rangle|1\rangle$, $|bc\rangle|0\rangle$, $|cb\rangle|0\rangle$, $|ac\rangle|0\rangle$, and $|ca\rangle|0\rangle$. From these, we can construct two states that are dark with respect to the couplings Ω and g for each atom (i.e., zero-eigenvalue states of H):

$$|\Psi_1^{\text{dark}}\rangle_j \propto |b_j\rangle|0\rangle - (\Omega/g)|c_j\rangle|1\rangle, \quad (9)$$

for $j=1$ or 2 . The effects of cavity decay may be included in the interaction picture (defined by H_I) by replacing g with $ge^{-\kappa t}$. For two excitations, the manifold of coupled states consists of $|cc\rangle|2\rangle$, $|bc\rangle|1\rangle$, $|cb\rangle|1\rangle$, $|bb\rangle|0\rangle$, $|ba\rangle|0\rangle$, $|ab\rangle|0\rangle$, and $|aa\rangle|0\rangle$, which supports a two-atom dark state:

$$|\Psi_2^{\text{dark}}\rangle \propto |bb\rangle|0\rangle - [\sqrt{2}(\Omega/g)](|bc\rangle + |cb\rangle)|1\rangle/\sqrt{2} + [(\Omega/g)^2/\sqrt{2}]|cc\rangle|2\rangle. \quad (10)$$

In the preparation stage, Alice follows the above dark states, and by tuning $\Omega(t)$ to go from $\Omega \ll g$ to $\Omega \gg g$, achieves the following adiabatic transformations:

$$|cc\rangle_A|0\rangle_A \rightarrow |cc\rangle_A|0\rangle_A, \quad (11)$$

$$|bc\rangle_A|0\rangle_A \rightarrow |cc\rangle_A|1\rangle_A, \quad (12)$$

$$|cb\rangle_A|0\rangle_A \rightarrow |cc\rangle_A|1\rangle_A, \quad (13)$$

$$|bb\rangle_A|0\rangle_A \rightarrow |cc\rangle_A|2\rangle_A, \quad (14)$$

where in the last line, we have used the approximation that $(\Omega/g)^2 \gg 2(\Omega/g)$ since $\Omega \gg g$. In this way, she transfers her given atomic state in Eq. (1) to the corresponding field state in time t_p , resulting in the atom-field state

$$|\Psi\rangle_A = (C_0|0\rangle_A + C_1|1\rangle_A + C_2|2\rangle_A)|cc\rangle_A/\sqrt{N_1}, \quad (15)$$

where, including the effects of cavity decay, we have

$$C_0 = C_0^I, \quad (16)$$

$$C_1 = e^{-\kappa t_p} \sqrt{2} C_1^I, \quad (17)$$

$$C_2 = e^{-2\kappa t_p} C_2^I, \quad (18)$$

and $N_1 = |C_0|^2 + |C_1|^2 + |C_2|^2$ is for normalization.

At the same time, Bob places two atoms in his cavity B in the state $|b\rangle$, and by tuning $\Omega(t)$, evolves his system from $|bb\rangle_B|0\rangle_B$ to the two-atom dark state $|\Psi_2^{\text{dark}}\rangle$ at time $t=t_p$:

$$|\Psi\rangle_B = \left(D_0|bb\rangle_B|0\rangle_B + D_1 \frac{|bc\rangle_B + |cb\rangle_B}{\sqrt{2}} |1\rangle_B + D_2|cc\rangle_B|2\rangle_B \right) / \sqrt{N_2}, \quad (19)$$

where $D_0=1$, $D_1=-\sqrt{2}(\Omega/g)$, $D_2=(\Omega/g)^2/\sqrt{2}$, and $N_2 = |D_0|^2 + |D_1|^2 + |D_2|^2$. Note that cavity decay does not affect the relative amplitudes of the dark state, as this is always defined with respect to the original Hamiltonian H . However, and this is the key trick, Bob can choose $\Omega(t_p)/g$ to be of the form $\alpha e^{-\kappa t_p}$ to complement the decay in Alice's cavity:

$$D_0 = 1, \quad (20)$$

$$D_1 = -\alpha \sqrt{2} e^{-\kappa t_p}, \quad (21)$$

$$D_2 = (\alpha^2/\sqrt{2}) e^{-2\kappa t_p}. \quad (22)$$

To summarize, following independent preparations, the joint state of Alice's and Bob's systems is

$$|\Psi\rangle_{AB}^{\text{in}} = |\Psi\rangle_A \otimes |\Psi\rangle_B. \quad (23)$$

In the detection stage, Alice waits for two (and only two) clicks on her detectors from photons arriving from both cavities. The first click occurs at time $t=t_1$ after preparation, and the second click occurs at time $t=t_2$ after preparation. The simultaneous detection process leaves the joint state of Alice and Bob in (see Appendix)

$$\begin{aligned} |\Psi\rangle_{AB}^{\text{out}} &\propto \hat{D}^\pm e^{-\kappa \hat{a}^\dagger \hat{a} (t_2 - t_1)} \hat{D}^\pm e^{-\kappa \hat{a}^\dagger \hat{a} t_1} |\Psi\rangle_A \otimes |\Psi\rangle_B \\ &\propto |\psi\rangle_B^{\text{out}} |cc\rangle_A |0\rangle_A |0\rangle_B + e^{-\kappa t_2} [\dots], \end{aligned} \quad (24)$$

where the cumulative time decay $e^{-\kappa t_2}$ damps out the non-zero, final photon number contributions (denoted by the dots), and we are left in the long-time regime with the following decoherence-free atomic state in Bob's cavity:

TABLE I. Prefactors for the different detection scenarios in the final teleported state $|\psi\rangle_B^{\text{out}}$ for two atoms. r and t are the reflection and transmission coefficients for the beam splitter, and $\alpha = (\Omega/(g e^{-\kappa t_p}))$ is the dark state parameter that Bob chooses initially.

| | η_0 | η_1 | η_2 |
|----------|--------------------------|------------------------|--------------|
| D_+D_+ | $(\alpha^2/\sqrt{2})r^2$ | $-(2\sqrt{2}\alpha)rt$ | t^2 |
| D_-D_- | $(\alpha^2/\sqrt{2})t^2$ | $(2\sqrt{2}\alpha)rt$ | r^2 |
| D_+D_- | $-\alpha^2 rt$ | $2\alpha(t^2 - r^2)$ | $\sqrt{2}rt$ |

$$|\psi\rangle_B^{\text{out}} = \left(\eta_0 C_0^I |cc\rangle_B + \eta_1 C_1^I \frac{|bc\rangle_B + |cb\rangle_B}{\sqrt{2}} + \eta_2 C_2^I |bb\rangle_B \right) / \sqrt{N_3}, \quad (25)$$

where $N_3 = |\eta_0 C_0^I|^2 + |\eta_1 C_1^I|^2 + |\eta_2 C_2^I|^2$, and the coefficients η_m are given in Table I for the three detection scenarios. To complete the teleportation protocol, Alice needs to inform Bob (by classical means) which detectors clicked, and Bob performs unitary operations to his final state (see below) to make his final teleported state $|\psi\rangle_B^{\text{out}}$ look as close as possible to the initial state $|\psi\rangle_A^{\text{in}}$.

The raw fidelity of the protocol, $F = |\langle \psi_{\text{in}} | \psi_{\text{out}} \rangle|^2$, depends on both the state to be teleported (the coefficients C_m^I) and the detection scenario that is realized. If only one of the Dicke states is present initially ($C_m^I = 1$ for some m), then the fidelity is automatically unity when the protocol succeeds (i.e., when two and only two clicks are recorded). For the entire superposition, the fidelity depends on the *postprocessing* of the teleported state. That is, knowing the coefficients η_m in Table I allows us to choose an appropriate unitary transform (which depends on the detection scenario) to maximize the fidelity after the protocol has ended. We emphasize that this *does not* depend on the initial choice of α and r , as any detection scenario can be optimized postdetection by subsequent unitary evolution of the teleported state $|\psi\rangle_B^{\text{out}}$. The free parameters α and r are chosen only to ensure that all the prefactors η_m are nonzero.

Thus, the probability of success of the teleportation protocol depends solely on the fact that we get two, and only two, clicks on both detectors. Note that the possibilities include [cf. Eqs. (15), (19), and (23)] zero, one, or two photons from each cavity, leading to 0–4 clicks in both detectors. We analyze the success probability in more detail below.

III. N_a -ATOM TELEPORTATION

To appreciate the scaling of the protocol, we discuss the generalization of our scheme to an arbitrary number of atoms N_a in each cavity. The interaction Hamiltonian in Eq. (2) generalizes to

$$H = \sum_{i=1}^{N_a} [\hbar \Omega(t) (|a_i\rangle\langle b_i| + |b_i\rangle\langle a_i|) + \hbar g (|a_i\rangle\langle c_i| \hat{a} + |c_i\rangle\langle a_i| \hat{a}^\dagger)]. \quad (26)$$

We use the notation $|b^{\otimes m} c^{\otimes N_a - m}\rangle$ to denote a normalized, symmetric Dicke state where m atoms are in the level b and

$N_a - m$ atoms are in the level c [20]. From combinatorics, there are $P(N_a, m) = N_a! / [(N_a - m)! m!]$ terms constituting the entangled state $|b^{\otimes m} c^{\otimes N_a - m}\rangle$. The initial state to be teleported is assumed to be of the form

$$|\psi\rangle_A^{\text{in}} = \sum_{m=0}^{N_a} C_m^I |b^{\otimes m} c^{\otimes N_a - m}\rangle_A. \quad (27)$$

Using adiabatic evolution in the presence of cavity decay, and utilizing dark states composed of an arbitrary number of atoms in the cavity [see Eq. (29) below], Alice maps the unknown N_a -atom state given above to the equivalent photon state in time t_p :

$$|\Psi\rangle_A = \frac{1}{\sqrt{\mathcal{N}_1}} \left(\sum_{p=0}^{N_a} C_p |p\rangle_A \right) |c^{\otimes N_a}\rangle_A, \quad (28)$$

where $C_p = e^{-p\kappa t_p} \sqrt{P(N_a, p)} C_p^I$. Meanwhile, Bob prepares his cavity in the N_a -atom dark state

$$|\Psi\rangle_B = \frac{1}{\sqrt{\mathcal{N}_2}} \sum_{p=0}^{N_a} D_p |b^{\otimes N_a - p} c^{\otimes p}\rangle_B |p\rangle_B, \quad (29)$$

where $D_p = e^{-p\kappa t_p} (-\alpha)^p \sqrt{P(N_a, p) / p!}$, and we have used the same index p to denote complementary atomic and photonic excitations in the dark state.

In the detection stage, Alice waits for N_a clicks in the two detectors. Assuming n clicks occur in D_+ and $N_a - n$ clicks in D_- , the teleported state becomes

$$|\psi^{(n)}\rangle_B^{\text{out}} = \frac{1}{\sqrt{\mathcal{N}_3}} \sum_{m=0}^{N_a} \eta_m^{(n)} C_m^I |b^{\otimes m} c^{\otimes N_a - m}\rangle_B, \quad (30)$$

where for detection scenario n , the prefactor for C_m^I is given by

$$\eta_m^{(n)} = \sum_{i=0}^{\min(m, n)} (-1)^{n-i} \alpha^{N_a - m} \sqrt{m!} P(N_a, m) P(n, i) \\ \times P(N_a - n, m - i) r^{n+m-2i} t^{N_a - n - m + 2i}.$$

Successful teleportation of the superposition state occurs when there are exactly N_a photodetection events (for N_a atoms). Assuming no clicks occur during the preparation stage ($\kappa t_p \ll 1$), this occurs with probability $P_{\text{suc}} = (\sum_m |C_m D_{N_a - m}|^2) / \mathcal{N}_1 \mathcal{N}_2$, or

$$P_{\text{suc}}(N_a) = \frac{\sum_{m=0}^{N_a} [P(N_a, m)]^2 \alpha^{N_a - m} / (N_a - m)!}{2^{N_a} \sum_{m=0}^{N_a} P(N_a, m) \alpha^{N_a - m} / (N_a - m)!}. \quad (31)$$

A plot of this quantity is shown in Fig. 2, which shows that the fall off with N_a is an inverse power law. This indicates that in principle, the success probability has a polynomial scaling with the number of atoms.

IV. DISCUSSION

First, some remarks about fidelity. We note that optimizing the fidelity after the protocol has ended defines a problem

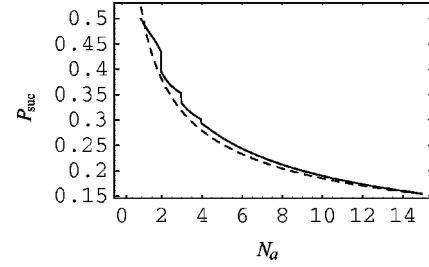

FIG. 2. The success probability of getting N_a photodetection events as a function of the number of atoms (solid line), fitted by the functional form $C/N_a^{0.45}$ (dashed line) for some constant C . Unit detection efficiency is assumed.

that, to our knowledge, has not been addressed before in the teleportation literature; namely, one where the weighting prefactors $\eta_m^{(n)}$ are known, but the coefficients C_m^I of the initial state are unknown. That is, the *relative* weights of the Dicke state superposition need to be equalized regardless of their absolute amplitudes, a problem which can be posed only in a state-averaged sense. We are currently addressing this issue. To give an example, consider the two-atom case in our scheme where the final state is given by Eq. (25). By appropriate choice of α and r , we can arrange the pre-factors to be such that $\eta_0 < \eta_1 < \eta_2$ for all detection scenarios. To equalize these weights, we might try a two-qubit rotation of states $|bb\rangle$ and $|cc\rangle$, which leaves the symmetric state $(|bc\rangle + |cb\rangle) / \sqrt{2}$ unchanged. The optimal rotation angle is determined by averaging the fidelity over all input coefficients C_m^I . For this example, we find that the state-averaged fidelity for the two-atom case can be increased to at least 0.96 for all detection scenarios. Successive unitary operations, which will introduce more control parameters, will further optimize this figure. A similar approach can be taken for larger number of atoms N_a , where with more atoms, we have a larger permutation of unitary operations at our disposal. Thus, the N_a scaling is not expected to constrain the optimization.

From the experimental standpoint, the fidelity will be degraded whenever the relative amplitudes/phases of the different Dicke states are unknown; for example, due to fluctuations in laser intensity, or asymmetry in the cavity coupling to different atoms.

We believe that the technology for implementing the proposed scheme is within reach of the current state-of-the-art for a small but significant number of atoms. For example, laser cooling and trapping of individual atoms in a high- Q cavity has recently become possible [21], and optical dipole traps have been demonstrated for a deterministic number of atoms [22]. Furthermore, three-level adiabatic passage and linear optics methods are well established experimentally. The principal constraint on asymptotic scalability will be the efficiency of the detectors, which in practice will cause the success probability to decrease exponentially. Another constraint is the need for a photon number resolving detector, as we require the postselection of the experiment based on N_a photodetection events. These issues are generic to quantum information schemes based on linear optics, and are currently active areas of research.

We anticipate that the main elements of the proposed scheme will be useful in a variety of quantum information

applications beyond teleportation. A key feature of the scheme is the multi-atom adiabatic passage that enables mapping of atomic Dicke-state entanglement to the photonic degrees of freedom. This method should prove useful for large-scale transfer of entangled quantum information between matter systems, a key requirement for distributed quantum computing. Furthermore, it also suggests the possibility of entanglement transfer between unequal number of atoms in both cavities, leading to applications such as dense coding and entanglement purification which can be fruitfully addressed with a mixed-state generalization of our scheme.

ACKNOWLEDGMENTS

One of us (M. S. Z), is grateful to Wilhelm Becker for helpful discussions. This research is supported by the Air

Force Office of Scientific Research, Air Force Research Laboratories (Rome, New York), DARPA-QuIST, TAMU TITF, and the Welch Foundation.

APPENDIX: SYSTEM STATES IN DIFFERENT TIME STEPS

We give below the details of the calculation for the two-atom case below. After preparation, Alice waits until she hears two (and only two) clicks at $t=t_1$ and $t=t_2$, following which the state in cavity A is teleported to cavity B successfully. For simplicity, the normalization factors are suppressed in Eqs. (A1)–(A7) below.

From Eqs. (15) and (19), at the end of the preparation stage (defined as $t=0$), we have

$$\begin{aligned}
 |\Psi\rangle_{AB}^{\text{in}} = & |\Psi\rangle_A \otimes |\Psi\rangle_B = [C_0 D_0 |bb\rangle_B |0\rangle_A |0\rangle_B + C_1 D_0 |bb\rangle_B |1\rangle_A |0\rangle_B + C_2 D_0 |bb\rangle_B |2\rangle_A |0\rangle_B + C_0 D_1 \frac{|bc\rangle_B + |cb\rangle_B}{\sqrt{2}} |0\rangle_A |1\rangle_B \\
 & + C_1 D_1 \frac{|bc\rangle_B + |cb\rangle_B}{\sqrt{2}} |1\rangle_A |1\rangle_B + C_2 D_1 \frac{|bc\rangle_B + |cb\rangle_B}{\sqrt{2}} |2\rangle_A |1\rangle_B + C_0 D_2 |cc\rangle_B |0\rangle_A |2\rangle_B + C_1 D_2 |cc\rangle_B |1\rangle_A |2\rangle_B \\
 & + C_2 D_2 |cc\rangle_B |2\rangle_A |2\rangle_B] |cc\rangle_A.
 \end{aligned} \tag{A1}$$

When $t=t_1$, before Alice registers the first click, the joint state of Alice's and Bob's systems has evolved conditional on no detector click, according to the evolution operator $\exp(-\kappa \hat{a}^\dagger \hat{a} t_1)$ for photons in each cavity:

$$\begin{aligned}
 |\Psi(t_1)\rangle = & [C_0 D_0 |bb\rangle_B |0\rangle_A |0\rangle_B + C_1 D_0 e^{-\kappa t_1} |bb\rangle_B |1\rangle_A |0\rangle_B + C_2 D_0 e^{-2\kappa t_1} |bb\rangle_B |2\rangle_A |0\rangle_B + C_0 D_1 e^{-\kappa t_1} \frac{|bc\rangle_B + |cb\rangle_B}{\sqrt{2}} |0\rangle_A |1\rangle_B \\
 & + C_1 D_1 e^{-2\kappa t_1} \frac{|bc\rangle_B + |cb\rangle_B}{\sqrt{2}} |1\rangle_A |1\rangle_B + C_2 D_1 e^{-3\kappa t_1} \frac{|bc\rangle_B + |cb\rangle_B}{\sqrt{2}} |2\rangle_A |1\rangle_B + C_0 D_2 e^{-2\kappa t_1} |cc\rangle_B |0\rangle_A |2\rangle_B \\
 & + C_1 D_2 e^{-3\kappa t_1} |cc\rangle_B |1\rangle_A |2\rangle_B + C_2 D_2 e^{-4\kappa t_1} |cc\rangle_B |2\rangle_A |2\rangle_B] |cc\rangle_A.
 \end{aligned} \tag{A2}$$

The first click then occurs and the time evolution of the system state is interrupted by a quantum jump at one of the two detectors D_+ or D_- . For the D_+ detector, we find

$$\begin{aligned}
 \hat{D}_+ |\Psi(t_1)\rangle = & (t a_A + r a_B) |\Psi(t_1)\rangle = [C_1 D_0 t e^{-\kappa t_1} |bb\rangle_B |0\rangle_A |0\rangle_B + \sqrt{2} C_2 D_0 t e^{-2\kappa t_1} |bb\rangle_B |1\rangle_A |0\rangle_B + C_0 D_1 r e^{-\kappa t_1} \frac{|bc\rangle_B + |cb\rangle_B}{\sqrt{2}} |0\rangle_A |0\rangle_B \\
 & + C_1 D_1 t e^{-2\kappa t_1} \frac{|bc\rangle_B + |cb\rangle_B}{\sqrt{2}} |0\rangle_A |1\rangle_B + C_1 D_1 r e^{-2\kappa t_1} \frac{|bc\rangle_B + |cb\rangle_B}{\sqrt{2}} |1\rangle_A |0\rangle_B + \sqrt{2} C_2 D_1 t e^{-3\kappa t_1} \frac{|bc\rangle_B + |cb\rangle_B}{\sqrt{2}} |1\rangle_A |1\rangle_B \\
 & + C_2 D_1 r e^{-3\kappa t_1} \frac{|bc\rangle_B + |cb\rangle_B}{\sqrt{2}} |2\rangle_A |0\rangle_B + \sqrt{2} C_0 D_2 r e^{-2\kappa t_1} |cc\rangle_B |0\rangle_A |1\rangle_B + C_1 D_2 t e^{-3\kappa t_1} |cc\rangle_B |0\rangle_A |2\rangle_B \\
 & + \sqrt{2} C_1 D_2 r e^{-3\kappa t_1} |cc\rangle_B |1\rangle_A |1\rangle_B + \sqrt{2} C_2 D_2 t e^{-4\kappa t_1} |cc\rangle_B |1\rangle_A |2\rangle_B + \sqrt{2} C_2 D_2 r e^{-4\kappa t_1} |cc\rangle_B |2\rangle_A |1\rangle_B] |cc\rangle_A, \\
 & \equiv |\Psi_+(t_1)\rangle,
 \end{aligned} \tag{A3}$$

while for D_- we have an analogous result with $t \rightarrow r$ and $r \rightarrow -t$. During the period $t_2 - t_1$, no clicks occur again by definition and the above state evolves according to $\exp[-\kappa \hat{a}^\dagger \hat{a} (t_2 - t_1)]$:

$$\begin{aligned}
|\Psi_+(t_2)\rangle = & e^{-\kappa t_1} [C_1 D_0 t |bb\rangle_B |0\rangle_A |0\rangle_B + \sqrt{2} C_2 D_0 t e^{-\kappa t_2} |bb\rangle_B |1\rangle_A |0\rangle_B + C_0 D_1 r \frac{|bc\rangle_B + |cb\rangle_B}{\sqrt{2}} |0\rangle_A |0\rangle_B \\
& + C_1 D_1 t e^{-\kappa t_2} \frac{|bc\rangle_B + |cb\rangle_B}{\sqrt{2}} |0\rangle_A |1\rangle_B + C_1 D_1 r e^{-\kappa t_2} \frac{|bc\rangle_B + |cb\rangle_B}{\sqrt{2}} |1\rangle_A |0\rangle_B + \sqrt{2} C_2 D_1 t e^{-2\kappa t_2} \frac{|bc\rangle_B + |cb\rangle_B}{\sqrt{2}} |1\rangle_A |1\rangle_B \\
& + C_2 D_1 r e^{-2\kappa t_2} \frac{|bc\rangle_B + |cb\rangle_B}{\sqrt{2}} |2\rangle_A |0\rangle_B + \sqrt{2} C_0 D_2 r e^{-\kappa t_2} |cc\rangle_B |0\rangle_A |1\rangle_B + C_1 D_2 t e^{-2\kappa t_2} |cc\rangle_B |0\rangle_A |2\rangle_B \\
& + \sqrt{2} C_1 D_2 r e^{-2\kappa t_2} |cc\rangle_B |1\rangle_A |1\rangle_B + \sqrt{2} C_2 D_2 t e^{-3\kappa t_2} |cc\rangle_B |1\rangle_A |2\rangle_B + \sqrt{2} C_2 D_2 r e^{-3\kappa t_2} |cc\rangle_B |2\rangle_A |1\rangle_B] |cc\rangle_A, \quad (\text{A4})
\end{aligned}$$

with an analogous result for $|\Psi_-(t_2)\rangle$ with $t \rightarrow r$ and $r \rightarrow -t$. Now the second click occurs at $t=t_2$. For the detection scenario D_+D_+ , we find that the final state is

$$\begin{aligned}
\hat{D}_+ |\Psi_+(t_2)\rangle = & (ta_A + ra_B) |\Psi_+(t_2)\rangle = \sqrt{2} e^{-\kappa t_1 - \kappa t_2} \left[\left(C_0 D_2 r^2 |cc\rangle_B \right. \right. \\
& + \sqrt{2} C_1 D_1 t r \frac{|bc\rangle_B + |cb\rangle_B}{\sqrt{2}} + C_2 D_0 t^2 |bb\rangle_B \Big) \\
& \times |0\rangle_A |0\rangle_B + e^{-\kappa t_2} (C_1 D_2 (2tr |cc\rangle_B |0\rangle_A |1\rangle_B \\
& + r^2 |cc\rangle_B |1\rangle_A |0\rangle_B) + C_2 D_1 (t^2 |cc\rangle_B |0\rangle_A |1\rangle_B \\
& + 2tr |cc\rangle_B |1\rangle_A |0\rangle_B) \\
& + e^{-2\kappa t_2} C_2 D_2 (t^2 |cc\rangle_B |0\rangle_A |2\rangle_B \\
& \left. + 2\sqrt{2} r t |cc\rangle_B |1\rangle_A |1\rangle_B + r^2 |cc\rangle_B |2\rangle_A |0\rangle_B) \right]. \quad (\text{A5})
\end{aligned}$$

For the detection scenario D_-D_+ or D_+D_- , we find

$$\begin{aligned}
\hat{D}_- |\Psi_+(t_2)\rangle = & (ra_A - ta_B) |\Psi_+(t_2)\rangle \\
= & \sqrt{2} e^{-\kappa t_1 - \kappa t_2} \left(\left(-\sqrt{2} C_0 D_2 r t |cc\rangle_B + (-t^2 \right. \right. \\
& + r^2) C_1 D_1 \frac{|bc\rangle_B + |cb\rangle_B}{\sqrt{2}} + C_2 D_0 \sqrt{2} t r |bb\rangle_B \Big) \\
& \times |0\rangle_A |0\rangle_B + e^{-\kappa t_2} [C_1 D_2 (-t^2 + r^2) |cc\rangle_B |0\rangle_A |1\rangle_B \\
& - r t |cc\rangle_B |1\rangle_A |0\rangle_B] + C_2 D_1 [r t |cc\rangle_B |0\rangle_A |1\rangle_B + (-t^2
\end{aligned}$$

$$\begin{aligned}
& + r^2 |cc\rangle_B |1\rangle_A |0\rangle_B] \\
& + e^{-2\kappa t_2} C_2 D_2 (t^2 |cc\rangle_B |0\rangle_A |2\rangle_B \\
& + 2\sqrt{2} r t |cc\rangle_B |1\rangle_A |1\rangle_B + r^2 |cc\rangle_B |2\rangle_A |0\rangle_B) \Big). \quad (\text{A6})
\end{aligned}$$

Finally for the detection scenario D_-D_- , we find

$$\begin{aligned}
\hat{D}_- |\Psi_-(t_2)\rangle = & (ra_A - ta_B) |\Psi_-(t_2)\rangle \\
= & \sqrt{2} e^{-\kappa t_1 - \kappa t_2} \left\{ \left(C_0 D_2 t^2 |cc\rangle_B \right. \right. \\
& - \sqrt{2} C_1 D_1 t r \frac{|bc\rangle_B + |cb\rangle_B}{\sqrt{2}} + C_2 D_0 r^2 |bb\rangle_B \Big) \\
& \times |0\rangle_A |0\rangle_B + e^{-\kappa t_2} [C_1 D_2 (-2tr |cc\rangle_B |0\rangle_A |1\rangle_B \\
& + t^2 |cc\rangle_B |1\rangle_A |0\rangle_B) + C_2 D_1 (r^2 |cc\rangle_B |0\rangle_A |1\rangle_B \\
& - 2tr |cc\rangle_B |1\rangle_A |0\rangle_B) \\
& + e^{-2\kappa t_2} C_2 D_2 (r^2 |cc\rangle_B |0\rangle_A |2\rangle_B \\
& \left. - 2\sqrt{2} r t |cc\rangle_B |1\rangle_A |1\rangle_B + t^2 |cc\rangle_B |2\rangle_A |0\rangle_B) \right\}. \quad (\text{A7})
\end{aligned}$$

In all cases, we can write the final atom-field state (upon two detection events) as in Eqs. (24) and (25), where the prefactors η_m given in Table I may be read out from the $|0\rangle_A |0\rangle_B$ component of Eqs. (A1)–(A7), making the substitutions for C_p and D_p in Eqs. (16)–(18) and (20)–(22).

- [1] C. H. Bennett, G. Brassard, C. Crepeau, R. Jozsa, A. Peres, and W. Wothers, *Phys. Rev. Lett.* **70**, 1895 (1993).
- [2] D. Bouwmeester, J.-W. Pan, K. Mattle, M. Eibl, H. Weifurter, and A. Zeilinger, *Nature (London)* **390**, 575 (1997).
- [3] A. Furusawa, J. L. Sorensen, S. L. Brounstein, C. A. Fuchs, H. J. Kimble, and E. S. Polzik, *Science* **282**, 706 (1998).
- [4] S. Bose, P. L. Knight, M. B. Plenio, and V. Vedral, *Phys. Rev. Lett.* **83**, 5158 (1999).
- [5] L. Davidovich, N. Zagury, M. Brune, J. M. Raimond, and S. Haroche, *Phys. Rev. A* **50**, R895 (1994); J. I. Cirac and A. S.

- Parkins, *ibid.* **50**, R4441 (1994); M. H. Y. Moussa, *ibid.* **55**, R3287 (1997); S.-B. Zheng and G.-C. Guo, *Phys. Lett. A* **232**, 171 (1997).
- [6] M. Riebe, H. Häffner, C. F. Roos, W. Hänsel, J. Benhelm, G. P. T. Lancaster, T. W. Körber, C. Becher, F. Schmidt-Kaler, D. F. V. James, and R. Blatt, *Nature (London)* **429**, 734 (2004); M. D. Barrett, J. Chiaverini, T. Schaetz, J. Britton, W. M. Itano, J. D. Jost, E. Knill, C. Langer, D. Leibfried, R. Ozeri, and D. J. Wineland, *ibid.* **429**, 737 (2004).
- [7] M. O. Scully and M. S. Zubairy, *Quantum Optics* (Cambridge

- University Press, London, 1997).
- [8] M. Ikram, S.-Y. Zhu, and M. S. Zubairy, *Phys. Rev. A* **62**, 022307 (2000).
- [9] M. S. Zubairy, *Phys. Rev. A* **58**, 4368 (1998).
- [10] C. Cabrillo, J. I. Cirac, P. Garca-Fernandez, and P. Zoller, *Phys. Rev. A* **59**, 1025 (1999).
- [11] M. B. Plenio, S. F. Huelga, A. Beige, and P. L. Knight, *Phys. Rev. A* **59**, 2468 (1999); see also G. J. Yang, O. Zobay, and P. Meystre, *ibid.* **59**, 4012 (1999).
- [12] J. I. Cirac, P. Zoller, H. J. Kimble, and H. Mabuchi, *Phys. Rev. Lett.* **78**, 3221 (1997); S. J. van Enk, H. J. Kimble, J. I. Cirac, and P. Zoller, *Phys. Rev. A* **59**, 2659 (1999).
- [13] T. Pellizzari, *Phys. Rev. Lett.* **79**, 5242 (1997).
- [14] R. H. Dicke, *Phys. Rev.* **93**, 99 (1954).
- [15] L. M. Duan and H. J. Kimble, *Phys. Rev. Lett.* **90**, 253601 (2003).
- [16] M. B. Plenio and P. L. Knight, *Rev. Mod. Phys.* **70**, 101 (1998).
- [17] J. Dalibard, Y. Castin, and K. Molmer, *Phys. Rev. Lett.* **68**, 580 (1992).
- [18] H. J. Carmichael, *An Open Systems Approach to Quantum Optics* (Springer-Verlag, Berlin, 1993).
- [19] M. S. Shahriar, J. A. Bowers, B. Demsky, P. S. Bhatia, S. Lloyd, P. R. Hemmer, and A. E. Craig, *Opt. Commun.* **195**, 411 (2001).
- [20] M. Sargent III, M. O. Scully, and W. E. Lamb, Jr., *Laser Physics* (Addison-Wesley, Reading, MA, 1974), App. G.
- [21] J. Ye, D. W. Vernooy, and H. J. Kimble, *Phys. Rev. Lett.* **83**, 4987 (1999).
- [22] D. Frese, B. Ueberholz, S. Kuhr, W. Alt, D. Schrader, V. Gomer, and D. Meschede, *Phys. Rev. Lett.* **85**, 3777 (2000).