

Quantum behavior of a charged particle in an axial magnetic field

Ashok Das

Department of Physics and Astronomy, University of Rochester, Rochester, New York, USA

J. Frenkel and S. H. Pereira

Instituto de Física, Universidade de São Paulo, São Paulo, Brazil

J. C. Taylor

DAMTP, Centre for Mathematical Sciences, Cambridge University, Cambridge, United Kingdom

(Received 5 May 2004; revised manuscript received 2 June 2004; published 17 November 2004)

We study some aspects of the quantum theory of a charged particle moving in a time-independent, unidirectional magnetic field. When the field is uniform, we make a few clarifying remarks on the use of angular momentum eigenstates and momentum eigenstates with the diamagnetism of a free electron gas as an example. When the field is nonuniform but weakly varying, we discuss both perturbative and nonperturbative methods for studying a quantum mechanical system. As an application, we derive the quantized energy levels of a charged particle in a Helmholtz coil, which go over to the usual Landau levels in the limit of a uniform field.

DOI: 10.1103/PhysRevA.70.053408

PACS number(s): 03.65.Ge

I. INTRODUCTION

Although the quantum theory of a charged particle moving in a unidirectional constant magnetic field has been studied over many decades (for some textbook treatments, see, for example, [1]), we would like to make some clarifying remarks which we believe are useful. In studying this problem, one has to make a choice of the gauge. Different gauge choices, of course, lead to a trivial phase redefinition of the wave function. Moreover, corresponding to specific gauges, one chooses a wave function which is an eigenstate either of the momentum operator (which has continuous eigenvalues) of the angular momentum operator (which has discrete eigenvalues). In Sec. II we point out that such a choice is unessential and derive an explicit relation between the two bases. This is then used in the treatment of diamagnetism of a free electron gas with angular momentum eigenstates. In Sec. III, we study the case when the magnetic field has a weak z dependence (where the z axis is in the direction of the field). Then, there must be also a weak radial field and we work under conditions where it is consistent to treat this component of the field perturbatively. We find the energy eigenvalues for certain models of the z dependence. These models could approximate the field between two parallel circular currents. In Sec. IV, we discuss the form of the wave function for large quantum numbers associated with the z motion, using a nonperturbative approach in a slowly varying field. As an application, we study in Sec. V the structure of the quantized energy levels of a charged particle in a Helmholtz coil, which are specified by two quantum numbers. The first is associated with the motion in the (x, y) plane, while the second characterizes the motion in the z direction. This energy spectrum may be regarded as a generalization of the Landau levels [1] to the case of a slowly varying magnetic field. A brief conclusion is presented in Sec. VI.

II. UNIFORM MAGNETIC FIELD

We take the field to be in the z direction, and to have z component B . We take the particle's charge and mass to be e and m . Two gauges for the vector potential which are commonly used are

$$\mathbf{A} = (-By/2, Bx/2, 0) \quad (1)$$

and

$$\mathbf{A} = (-By, 0, 0). \quad (2)$$

But the difference between these two gauges can only be trivial, since the wave functions just differ by the phase factor

$$\omega = \exp[ieBxy/(2c\hbar)]. \quad (3)$$

Therefore we might just as well choose (1).

For brevity, we define

$$\mathcal{B} = eB/c. \quad (4)$$

The Hamiltonian in gauge (1) is

$$\begin{aligned} H &= \frac{1}{2m} [(p_x - \mathcal{B}y/2)^2 + (p_y + \mathcal{B}x/2)^2 + p_z^2] \\ &= \frac{1}{2m} [p_x^2 + p_y^2 + p_z^2 + \mathcal{B}^2(x^2 + y^2)/4 + \mathcal{B}L] \\ &= H' + p_z^2/2m, \end{aligned} \quad (5)$$

where

$$p_x = -i\hbar \frac{\partial}{\partial x}, \quad p_y = -i\hbar \frac{\partial}{\partial y}, \quad p_z = -i\hbar \frac{\partial}{\partial z}, \quad (6)$$

$$L = xp_y - yp_x. \quad (7)$$

We define also

$$P_x = p_x + \mathcal{B}y/2, \quad P_y = p_y - \mathcal{B}x/2. \quad (8)$$

Then the operators P_x, P_y , and L each commute with H and p_z . But they do not commute with each other:

$$[P_x, P_y] = i\hbar\mathcal{B}, \quad [L, P_x] = i\hbar P_y, \quad [L, P_y] = -i\hbar P_x. \quad (9)$$

We may choose the wave function $\psi(x, y, z)$ to be an eigenfunction of p_z with eigenvalue $\hbar k_z$:

$$\psi(x, y, z) = e^{ik_z z} \phi(x, y), \quad (10)$$

$$H\psi = e^{ik_z z} [H' + \hbar^2 k_z^2 / (2m)] \phi, \quad (11)$$

and from now on we will be concerned with H' and $\phi(x, y)$.

We may choose ϕ to be an eigenfunction of any one of the three operators P_x, P_y, L . We discuss the two cases (i) eigenfunction of P_x (by rotational invariance we can equally well choose it to be an eigenstates of P_y) and (ii) eigenfunction of L . These wave functions may be written in a more compact form if we define a magnetic length l by

$$l = \sqrt{\hbar/\mathcal{B}}. \quad (12)$$

In case (i), we have

$$\phi_{k_x, n}(x, y) = \frac{1}{\sqrt{2\pi}} e^{ik_x x} e^{-ixy/2l^2} \xi_n(y), \quad (13)$$

where $\hbar k_x$ is the eigenvalue of P_x , and ξ_n satisfies

$$\frac{\hbar^2}{2m} \left[-\frac{\partial^2}{\partial y^2} + \{(y/l^2) - k_x\}^2 \right] \xi_n(y) = E' \xi_n(y), \quad (14)$$

E' being the eigenvalue of H' . This equation describes a simple harmonic oscillator whose equilibrium point is shifted, and the eigenfunctions have the form

$$\xi_n(y) = l^{-1/2} u_n[(y - \eta)/l], \quad (15)$$

where n is a positive integer,

$$\eta = l^2 k_x, \quad E' = \frac{\hbar\mathcal{B}}{m} \left(n + \frac{1}{2} \right), \quad (16)$$

and $u_n(w)$ is the real, normalized solution of

$$\left[-\frac{\partial^2}{\partial w^2} + w^2 \right] u_n(w) = (2n + 1) u_n(w). \quad (17)$$

Next we take the case (ii), where we use energy eigenfunctions which are also eigenfunctions of angular momentum L with eigenvalue $\hbar M$. We denote these normalized wave functions by

$$\zeta_{n, M}(x, y). \quad (18)$$

Eigenfunctions of type (i), in Eq. (13), are non-normalizable and have a continuous degeneracy, whereas those of type (ii) in Eq. (18) are normalized and have a discrete degeneracy. Nevertheless, it should be possible to express each type in terms of the other. To this end, we consider a superposition of the form

$$\chi_{n, f} = \int dk_x f(k_x) \phi_{k_x, n}(x, y) \quad (19)$$

where f is some function to be determined and

$$\int dx dy \chi_{n', f}^* \chi_{n, f} = \delta_{nn'} \int dk_x |f(k_x)|^2. \quad (20)$$

In order to make Eq. (19) an eigenstate of L , we require

$$\begin{aligned} \hbar M \chi_{n, f} = L \chi_{n, f} = & -i\hbar(2\pi l)^{-1/2} \int dk_x f(k_x) \left(x \frac{\partial}{\partial y} - y \frac{\partial}{\partial x} \right) \\ & \times \exp[ik_x x - ixy/2l^2] \\ & \times u_n[(y/l) - lk_x]. \end{aligned} \quad (21)$$

We convert x and x^2 into derivatives of $e^{ik_x x}$ and integrate by parts to put these derivatives onto f and u . In this way, we find that Eq. (21) is satisfied provided f obeys

$$-\frac{1}{l^2} \frac{d^2 f}{dk_x^2} + l^2 k_x^2 f = [2(n - M) + 1] f. \quad (22)$$

This equation is consistent, and its normalized solution is just

$$f(k_x) = l^{1/2} u_{n-M}[lk_x]. \quad (23)$$

Thus, finally, the required eigenfunction of L is determined to be

$$\zeta_{n, M}(x, y) = l^{1/2} \int dk_x u_{n-M}(lk_x) \phi_{k_x, n}(x, y). \quad (24)$$

Using the orthonormality of the u_n coefficients in Eq. (24), we can invert this equation to find the momentum eigenfunctions in terms of the angular momentum eigenfunctions:

$$\phi_{k_x, n}(x, y) = l^{1/2} \sum_{M=-\infty}^n u_{n-M}(lk_x) \zeta_{n, M}(x, y). \quad (25)$$

The textbook treatment (see, for example, [2]) of the diamagnetism of a free electron gas is usually formulated in terms of the eigenfunctions of momentum (13). The sample is considered to have a finite size with dimensions S_x, S_y in the x and y directions, in which case states contribute only for

$$|\eta| < S_y. \quad (26)$$

So the number of states with a given energy and value of k_z is

$$\frac{\mathcal{B} S_x S_y}{2\pi\hbar} = \frac{S_x S_y}{2\pi l^2}. \quad (27)$$

It ought to be possible to carry out the analysis using the angular momentum eigenfunctions (18). In that case, it is natural to consider a cylindrical sample, axis along the z axis, with radius R . The asymptotic form of the wave function (18), for large ρ , is proportional to

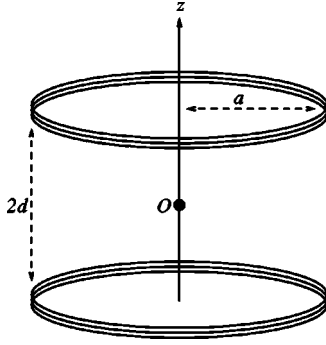

FIG. 1. Schematic illustration of a Helmholtz coil.

$$e^{iM\phi} \rho^{2n-M} \exp(-\rho^2/4l^2), \quad (28)$$

and this has its maximum at

$$\rho_{max} = \sqrt{2(2n-M)}l. \quad (29)$$

Thus we expect states to contribute for

$$2n-M < \frac{R^2}{2l^2}. \quad (30)$$

Then, for given n , the range of M is

$$2n - \frac{R^2}{2l^2} \leq M \leq n, \quad (31)$$

so that the number of possible values of M is

$$\frac{R^2}{2l^2} - n. \quad (32)$$

The relevant values of n are of order $(mkTl^2/\hbar^2)$ which is small compared to (R^2/l^2) for typical values of B , R , and T (temperature). Thus (32) gives a factor

$$\frac{\pi R^2}{2\pi l^2}, \quad (33)$$

which is proportional to the area just as in Eq. (27).

III. WEAKLY VARYING MAGNETIC FIELD

We now allow the magnetic field to vary slowly with z , but we restrict ourselves to motion near the z axis. Along the axis, we use an expansion

$$B_z(z) = B_0[1 + b_1(z/a)^2 + b_2(z/a)^4 + \dots] \quad (34)$$

where a is a characteristic length.

A realistic case would be a pair of two similar current loops, each perpendicular to the common z axis and of radius a , separated by a distance $2d$. This system, known as the Helmholtz coil, is shown in Fig. 1.

Near the origin the field has an expansion of the above form, where B_0 is determined by the current carried by the loops and [in terms of $r=(d/a)^2$]

$$b_1 = \frac{3(4r-1)}{2(r+1)^2}, \quad b_2 = \frac{15(1-12r+8r^2)}{8(r+1)^4}. \quad (35)$$

Off the axis, the magnetic field must have some radial component. Up to second order (that is, the b_1 term), we take the vector potential to be

$$\mathbf{A} = \frac{1}{2}B_0[1 + b_1(z^2 - \rho^2/4)/a^2](-y, x, 0). \quad (36)$$

This form follows by rotational symmetry (if the field is generated by currents in circles about the axis), together with the gauge choice $\nabla \cdot \mathbf{A} = 0$ and Maxwell's equation $\nabla^2 \mathbf{A} = 0$.

As the leading approximation, we keep just the $b_1 z^2$ term in Eq. (34) (we shall see that the ρ^2 term is effectively smaller). We seek an energy eigenfunction of the Hamiltonian (5), with B now z dependent, of the form

$$W(z)\Phi(x, y). \quad (37)$$

Then the equation for W is (we now define l to be $\sqrt{\hbar/B_0}$)

$$-\frac{d^2W}{dz^2} + (2n+1)\frac{b_1 z^2}{a^2 l^2} W = \frac{2m\Delta E}{\hbar^2} W, \quad (38)$$

where the second term on the left comes from E' in Eq. (14) when B is z dependent. This is just the equation for a simple harmonic oscillator and, for $k_z=0$, the energy associated with the z motion is

$$\Delta E = \frac{\hbar^2}{mal} \sqrt{b_1(2n+1)} \left(N + \frac{1}{2}\right). \quad (39)$$

We can now treat the z^4 term in Eq. (34) and the ρ^2 term in Eq. (36) as perturbations. These terms are of the same order. This is because the transverse size of the wave function is of order l whereas the longitudinal size is of order \sqrt{la} . Note that, as an example, for a magnetic flux density of 1 T, $l=2.5 \times 10^{-8}$ m.

Treating the z^4 term by perturbation theory, we find an additional energy

$$\Delta E' = \frac{3\hbar^2}{4ma^2 b_1(2n+1)} (1 + 2N + 2N^2). \quad (40)$$

Note that this is independent of B and usually very small if a is macroscopic. However, for large values of N , the contributions from the b_2 term and higher terms in Eq. (34) may be significant.

We also treat by perturbation theory the ρ^2 term in Eq. (36). To this end we require, inserting the ρ^2 term in Eq. (36) into the Hamiltonian (5),

$$\Delta E'' = -\frac{\hbar b_1}{16ma^2 l^2} \int dx dy \phi_{n,M}^* (2L\rho^2 + \hbar\rho^4/l^2) \phi_{n,M}. \quad (41)$$

These expectation values can be worked out using

$$\int dx dy \psi^* \rho^2 \psi = (2n - M + 1)l^2, \quad (42)$$

$$\int dx dy \psi^* \rho^4 \psi = [(2n - M + 1)^2 + 2n(n - M) + 2n - M + 1] l^4. \quad (43)$$

As a result, we have

$$\Delta E'' = -\frac{\hbar^2 b_1}{16ma^2} [6n(n+1) - M(M+1) + 2(1-nM)]. \quad (44)$$

This is independent of B and, in general, is much smaller than Eq. (40) for large values of N .

IV. NONPERTURBATIVE APPROACH TO A SLOWLY VARYING FIELD

We have seen that when the quantum number associated with the z motion is large, $N \gg n$, the dependence of B_z upon ρ may be neglected in first approximation. In this case, the vector potential may be written as

$$\mathbf{A} = \frac{1}{2} B_z(z) (-y, x, 0). \quad (45)$$

This leads to the Schrödinger equation

$$\frac{\partial^2 \psi}{\partial \rho^2} + \frac{1}{\rho} \frac{\partial \psi}{\partial \rho} - \left(\frac{M^2}{\rho^2} + \frac{eB_z M}{\hbar c} + \frac{e^2 B_z^2}{4\hbar^2 c^2} \rho^2 \right) \psi + \frac{\partial^2 \psi}{\partial z^2} = -\frac{2m}{\hbar^2} E \psi, \quad (46)$$

where we have taken the energy eigenfunction to be also an eigenfunction of the angular momentum L_z with eigenvalue $\hbar M$. Let us consider a solution of the form

$$\psi(\phi, \rho, z) = F(\phi, \rho, z) f(z) \quad (47)$$

and assume, since the field is slowly varying, that

$$\left| \frac{\partial F}{\partial z} \right| \ll \left| \frac{\partial F}{\partial \rho} \right|. \quad (48)$$

Then, the Schrödinger equation (46) takes the form

$$\frac{1}{F} \left[\frac{\partial^2 F}{\partial \rho^2} + \frac{1}{\rho} \frac{\partial F}{\partial \rho} \right] - \frac{M^2}{\rho^2} - \frac{eB_z M}{\hbar c} - \frac{e^2 B_z^2}{4\hbar^2 c^2} \rho^2 = - \left[\frac{1}{f} \frac{d^2 f}{dz^2} + \frac{2m}{\hbar^2} E \right]. \quad (49)$$

The right-hand side of Eq. (49) depends on z only, so that we have

$$\frac{d^2 f}{dz^2} + \frac{2m}{\hbar^2} E f = \frac{2m}{\hbar^2} E'(z) f \quad (50)$$

and

$$\frac{\partial^2 F}{\partial \rho^2} + \frac{1}{\rho} \frac{\partial F}{\partial \rho} - \left(\frac{M^2}{\rho^2} + \frac{eB_z M}{\hbar c} + \frac{e^2 B_z^2}{4\hbar^2 c^2} \rho^2 \right) F = -\frac{2m}{\hbar^2} E'(z) F. \quad (51)$$

But we know how to solve Eq. (51), in which z is just a parameter. Comparing with Eq. (16), we see that

$$E'(z) = \frac{e\hbar}{mc} \left(n + \frac{1}{2} \right) B_z(z). \quad (52)$$

Thus, Eq. (50) may be written as

$$\frac{d^2 f}{dz^2} + \frac{2m}{\hbar^2} \left[E - \frac{e\hbar(2n+1)}{2mc} B_z(z) \right] f = 0, \quad (53)$$

which is just an ordinary differential equation.

We can now check the assumption (48). The solutions of Eq. (51) have the form (18), namely,

$$F(\phi, \rho, z) = \zeta_{n,M} \left(\phi, \sqrt{\frac{eB_z}{2\hbar c}} \rho \right). \quad (54)$$

Hence, the condition (48) requires that

$$\frac{\rho}{B_z} \frac{dB_z}{dz} \ll 1. \quad (55)$$

Although this cannot be satisfied for all ρ , we note that the solution (54) contains the factor

$$\exp\left(-\frac{eB_z}{4\hbar c} \rho^2\right), \quad (56)$$

so that typical values of ρ are of order $\sqrt{\hbar c/eB_z}$. Thus, we expect (55) to be valid for

$$\sqrt{\frac{\hbar c}{e}} \frac{1}{B_z^{3/2}} \frac{dB_z}{dz} \ll 1. \quad (57)$$

This can be satisfied provided we take B_z to be varying slowly enough. For instance, if $B_z(z)$ has the form (34) with $|z|$ of order a , then the left hand side of (57) is of order l/a , which is very small for typical values of B_0 and a .

V. QUANTIZED ENERGY LEVELS IN A HELMHOLTZ COIL

A simple example of a magnetic mirror is provided by the pair of current loops shown in Fig. 1. Then, as can be seen from Eqs. (34) and (35) for $2d > a$, the magnetic field can increase enough in the region near the current loops so that a charged particle may eventually be reflected out of this region toward the center of the coil. The classical restoring force which may confine the particle along the z axis is provided by the ρ component of the magnetic field:

$$\mathbf{B}(z) = -\frac{1}{2} \rho \frac{\partial B_z}{\partial z} \hat{\rho} + B_z \hat{z}. \quad (58)$$

which can be derived from Eq. (45) using $\mathbf{B} = \nabla \times \mathbf{A}$.

In this section, we will discuss the quantized energy levels of a charged particle in a Helmholtz coil. To this end, we will analyze the basic equation (53), where

$$B_z(z) = \frac{1}{2} B_0 (d^2 + a^2)^{3/2} \left\{ \frac{1}{[(z+d)^2 + a^2]^{3/2}} + \frac{1}{[(z-d)^2 + a^2]^{3/2}} \right\}. \quad (59)$$

The general behavior of this field, for $2d > a$, is shown in Fig. 2.

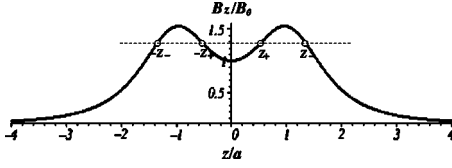

FIG. 2. Pattern of the field $B_z(z)$ in a Helmholtz coil. Circles indicate the classical turning points.

Since Eq. (53) was derived under the assumption that $N \gg 1$, our analysis will be more appropriate in the semiclassical regime. This may be studied conveniently in the WKB approximation, which is particularly useful since we are dealing with a slowly varying potential:

$$V(z) = \frac{e\hbar}{2mc} (2n+1) B_z(z). \quad (60)$$

One of the most interesting results arising from the WKB method is a semiclassical estimate for the quantized energy levels in a potential. Matching the WKB wave function at each of the classical turning points, which are determined by the relation $E = V(z)$, leads to the Bohr-Sommerfeld quantization condition

$$\int_{-Z_+}^{Z_+} \sqrt{2m[E - V(z)]} dz = \left(N + \frac{1}{2}\right) \pi \hbar, \quad (61)$$

where the classical turning points for bound motion, $\pm Z_+$, are situated inside the well as shown in Fig. 2. (We neglect, in first approximation, the very small probability of tunneling through the potential barrier.)

In general, Eq. (61) is rather complicated and can only be solved numerically. However, when d/a is somewhat larger than $1/2$, it may be solved in closed form, since in this case z/a will be effectively of order $1/2$ or smaller. Then, we can expand the potential $V(z)$ [see Eqs. (59) and (60)] up to terms which are of quartic order in z/a , as shown in Eqs. (34) and (35). In this approximation, the quantization condition (61) may be written in the form

$$\begin{aligned} \int_{-Z_+}^{Z_+} \sqrt{\mathcal{E} - 1 - b_1 \left(\frac{z}{a}\right)^2 - b_2 \left(\frac{z}{a}\right)^4} dz \\ = \pi \sqrt{\frac{c\hbar}{(2n+1)eB_0}} \left(N + \frac{1}{2}\right), \end{aligned} \quad (62)$$

where the dimensionless parameter \mathcal{E} is defined by

$$\mathcal{E} = \frac{2mc}{(2n+1)e\hbar B_0} E. \quad (63)$$

We can now determine explicitly the positions of the classical turning points, which are given by

$$Z_{\pm} = a \left[\frac{-b_1 \pm \sqrt{b_1^2 + 4b_2(\mathcal{E} - 1)}}{2b_2} \right]^{1/2}, \quad (64)$$

where $\pm Z_-$ are the turning points for unbound motion, which are situated outside the well as shown in Fig. 2. Then, the integral appearing in Eq. (62) can be evaluated in closed

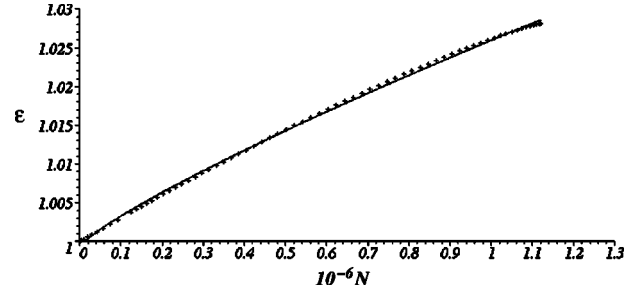

FIG. 3. Numerical solution (crosses) of Eq. (65) for the energy spectrum and plot (solid) of the form $N^{5/6}$ for large N .

form in terms of the complete elliptic integrals of the first (**F**) and second (**E**) kinds [3], with the result

$$\begin{aligned} \frac{2\sqrt{-b_2}}{3a^2} Z_- \left[(Z_+^2 - Z_-^2) \mathbf{F}\left(\frac{Z_+}{Z_-}\right) + (Z_+^2 + Z_-^2) \mathbf{E}\left(\frac{Z_+}{Z_-}\right) \right] \\ = \pi \sqrt{\frac{c\hbar}{(2n+1)eB_0}} \left(N + \frac{1}{2}\right). \end{aligned} \quad (65)$$

This is a transcendental equation which determines implicitly the energy in terms of the quantum number N . The energies of the bound states have an upper bound E^{\max} which corresponds to the maximum value of the potential. At this energy, $Z_+ = Z_-$, so that using Eqs. (63) and (64) we obtain

$$E_n^{\max} = \frac{e\hbar B_0}{2mc} (2n+1) \left(1 - \frac{b_1^2}{4b_2}\right). \quad (66)$$

When $Z_+ = Z_-$, Eq. (65) simplifies considerably and fixes the maximum value of the quantum number N , which is given by the relation

$$N_{\max} + \frac{1}{2} = \frac{\sqrt{2(2n+1)} b_1^{3/2} a}{3\pi |b_2| l}, \quad (67)$$

where $l = \sqrt{c\hbar/eB_0}$ is the magnetic length. Hence, N_{\max} is in general a very large number, which is in accordance with our previous assumption.

A more explicit relation giving E as a function of N can be obtained by solving numerically Eq. (65). As an example, the numerical solution for $n=0$ and $d/a=3/5$ is shown in Fig. 3. Here, the numerical values of $\mathcal{E}^{\max}=1.028$ and $N_{\max}=1.12 \times 10^6$ are in good agreement with the corresponding results obtained from the closed form expressions (66) and (67). One can see that the numerical solution can be fitted reasonably well, for large quantum numbers, by a simple phenomenological form like $N^{5/6}$.

Finally, we note from Eqs. (34) and (35) that for $d/a = 1/2$, $b_1=0$, and $b_2=-144/125$. Then, the system of the two current loops provides a practically uniform field in the central region of the Helmholtz coil. In this case, Eq. (66) reduces to the well known expression for the Landau levels which occur in a constant field. Therefore, one may regard the quantized energies described by Eqs. (65) and (66) as an extension of the Landau levels to the case of a slowly varying magnetic field.

VI. CONCLUSION

In this paper, we have discussed several aspects concerning the quantum behavior of a charged particle in a static magnetic field. We have treated the issue of the relation between the choice of gauge and the choice of the diagonal operators which commute with the Hamiltonian of the system. We have also developed some approaches which may be useful for physical applications in a slowly varying magnetic field. These methods have been applied to study the quantized energy levels of a charged particle in a weakly

varying field. Such a field may be present, for example, in a magnetic mirror like the Helmholtz coil. We have shown that this energy spectrum represents an interesting extension of the well known Landau levels which occur in a uniform magnetic field.

ACKNOWLEDGMENTS

This work was supported in part by U.S. DOE Grant No. DE-FG 02-91ER40685 and by CAPES, CNPq, and FAPESP, Brazil.

-
- [1] L. D. Landau and E. M. Lifshitz, *Quantum Mechanics: The Non-Relativistic Theory* (Butterworth-Heinemann, London, 1981); L. E. Ballentine, *Quantum Mechanics* (Prentice-Hall, Englewood Cliffs, NJ, 1990); S. Gasiorowicz, *Quantum Physics*, 2nd ed. (Wiley, New York, 1996); E. Merzbacher, *Quantum Mechanics*, 3rd ed. (Wiley, New York, 1998); J. Schwinger, *Quantum Mechanics* (Springer, Berlin, 2001).
- [2] R. E. Peierls, *Quantum Theory of Solids* (Oxford University Press, Oxford, 2001).
- [3] I. S. Gradshteyn and M. Ryzhik, *Tables of Integral Series and Products* (Academic Press, New York, 1980).