

# Single-particle nonlocality and entanglement with the vacuum

Gunnar Björk\* and Per Jonsson

*Department of Microelectronics and Information Technology, Royal Institute of Technology (KTH), Electrum 229, SE-164 40 Kista, Sweden*

Luis L. Sánchez-Soto

*Departamento de Óptica, Facultad de Ciencias Físicas, Universidad Complutense, 28040 Madrid, Spain*

(Received 15 March 2001; published 13 September 2001)

We propose a single-particle experiment that is equivalent to the conventional two-particle experiment used to demonstrate a violation of Bell's inequalities. Hence, we argue that quantum mechanical nonlocality can be demonstrated by single-particle states. The validity of such a claim has been discussed in the literature, but without reaching a clear consensus. We show that the disagreement can be traced to what part of the total state of the experiment one assigns to the (macroscopic) measurement apparatus. However, with a conventional and legitimate interpretation of the measurement process one is led to the conclusion that even a single particle can show nonlocal properties.

DOI: 10.1103/PhysRevA.64.042106

PACS number(s): 03.65.Ud, 42.50.Hz, 42.25.Hz, 42.65.-k

## I. INTRODUCTION

Single-photon sources are coming of age. The most common way to produce single-photon states with random emission times is to use photon-pair emission in spontaneous parametric down-conversion [1–3], followed by detection of one of the emitted photons. However, recently sources able to deliver a single photon *on demand* have been demonstrated, such as single-molecule emitters [4–7], electrically driven semiconductor *p-i-n* junctions [8], color centers in diamond [9,10], and semiconductor quantum dots [11–14]. As deterministic single-photon sources are being refined, it is relevant to discuss their potential in quantum information applications and in fundamental tests of physics. In this work we focus on the second of these questions, and specifically address if and how a single photon can be used to demonstrate quantum nonlocality.

Nonlocal properties of a single particle have been discussed by several authors [15–22]. However, most of the proposals have been (or can be) criticized for various reasons. The proposals by Tan, Walls, and Collett [15] and by Hardy [16] have been criticized as being multiparticle demonstrations of nonlocality in disguise [23,24] and for other reasons [25–27]. The criticism has been refuted as partially being a “semantic issue,” pertaining to the interpretation of the meaning of “single-particle nonlocality” [27]. The proposals put forth by Czachor [17] and by Home and Agarwal [18] are based on Mach-Zehnder interferometers, so the measurement does not take place in two spacelike separated locations and, consequently, the tests are not “loophole-free.” The remarkable inequality found by Revzen and Mann [19] is not derived in terms of experimentally testable entities; instead it demonstrates that the statistical interpretation of quantum mechanics is at odds with a local hidden-variables

theory. Peres [20] presents a very clear and concise discussion of single-particle nonlocality, but offers no suggestion for experimental implementation of the projective measurements his discussion centers around. In the experiment proposed by Gerry [21] the nonlocal properties of a single photon are transferred to two atoms prior to the measurement and, therefore, what is finally measured are the correlations between two particles, which makes the claim of single-particle nonlocality somewhat weaker. To the best of our knowledge, only one experiment has hitherto been performed that claims to be a single-particle test of noncontextual hidden variables [22], but, unfortunately, it is also based on self-interference in a Mach-Zehnder interferometer. Thus, one can conclude that so far no loophole-free demonstration of single-particle nonlocality has been performed.

In this paper we shall reexamine single-photon nonlocality. Specifically, we shall point out why early, conceptually simple, proposals [15,16] are very hard to implement in practice. We will argue that, while the proposal of Tan, Walls, and Collett [15] in our opinion is sound, by replacing the quadrature amplitude measurements the proposals are based on with phase measurements, one will obtain a *single-particle* equivalent to Bohm and Aharonov's two-particle version of the Einstein-Podolsky-Rosen (EPR) gedanken experiment [28]. The advantage with our proposal is that Bohm and Aharonov's version of the EPR experiment is well understood and familiar to most physicists. We will also show that an experiment involving relative phase, rather than phase, will be much simpler experimentally.

At first, it may seem counterintuitive that a single particle could have nonlocal properties, since observation of nonlocality would entail detection of some property of the particle at two spacelike separated locations. Clearly, detection of the particle at one location would immediately nullify any possibility of simultaneously recording the particle, or any property associated with the particle, at another location. The resolution of this apparent conflict is provided by quantum mechanical duality. Recall that any particle also has wavelike properties, and while the word “particle” brings to mind a

---

\*Present address: Departamento de Óptica, Facultad de Ciencias Físicas, Universidad Complutense, 28040 Madrid, Spain. Electronic address: gunnarb@ele.kth.se

pointlike, localized entity, waves are usually thought of as delocalized. Hence, the nonlocal properties of a single particle should naturally be sought in its wavelike properties.

Going back to the particle viewpoint, in order to be able to simultaneously record some joint property of a particle at spacelike separated regions, the particle must be prepared in a superposition state of being localized at one or the other location. The only other state that we can invoke in the superposition is the vacuum and, hence, single-particle nonlocality entails entanglement with the vacuum.

Entanglement with the vacuum is a controversial issue. We quote from Ref. [24]: “We point out that it can be very misleading to discuss entangled states in Fock space. Some states that seem to be entangled there are merely single-particle states in configuration space, with no EPR-type nonlocality implications. Other states that seem to be product states are clearly entangled states in configuration space. Especially misleading is the concept of ‘states entangled with the vacuum.’” We do not share the opinions voiced by Greenberger, Horne, and Zeilinger: since the Fock basis is a complete basis, it is just as good as any other to express and calculate quantum physics, provided the configuration space, or the modes of the system, are unambiguously defined. In this paper we shall show that this concept of “entanglement with the vacuum,” when properly used, can be very useful and, with a conventional interpretation of the measurement process, can lead to the conclusion of the nonlocality of a single particle.

## II. A SINGLE-PARTICLE BELL-INEQUALITY VIOLATION

The smallest state space in which it is possible to demonstrate EPR effects is a four-dimensional space (the product space of two spacelike separated two-state spaces). The basis vectors of this four-dimensional Hilbert space are conventionally taken as the Bell basis. In this paper we will focus on the Bell state

$$|\Psi_{-}\rangle = \frac{1}{\sqrt{2}}(|1\rangle_a \otimes |0\rangle_b - |0\rangle_a \otimes |1\rangle_b), \quad (2.1)$$

where the indices  $a$  and  $b$  usually are taken to refer to “particle  $a$ ” and “particle  $b$ ,” and where

$${}_a\langle 0|1\rangle_a = {}_b\langle 0|1\rangle_b = 0. \quad (2.2)$$

We stress that sufficient requirements for  $|\Psi_{-}\rangle$  to display nonlocal properties are that the indices  $a$  and  $b$  represent modes, or configurations, that are spacelike separated and that the orthogonality condition (2.2) is satisfied. What physical states the kets  $|0\rangle_a$ ,  $|1\rangle_a$ ,  $|0\rangle_b$ , and  $|1\rangle_b$  represent is *irrelevant* from a strictly fundamental point of view.

A single-particle state of the form (2.1) is

$$|\Psi\rangle = \frac{1}{\sqrt{2}}(|1,0\rangle - |0,1\rangle), \quad (2.3)$$

where we have suppressed the indices, abbreviated  $|m\rangle \otimes |n\rangle$  to  $|m,n\rangle$ , and used the number basis. This is a single

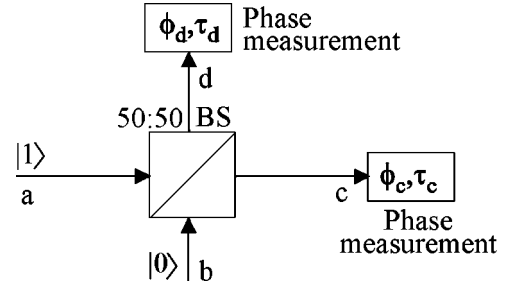

FIG. 1. A single photon is split in a spacelike fashion by a 50:50 beam splitter (BS). At the end of two arms  $c$  and  $d$ , the wave packets’ phase projections at angles  $\phi_c$  and  $\phi_d$  are measured at times  $\tau_c$  and  $\tau_d$  after the single photon was generated.

particle entangled with the vacuum (in the following we shall assume that the particle is a photon). The state can be generated by letting a one-photon state prepared in a well specified spatiotemporal mode impinge on a 50:50 beam splitter (see Fig. 1). If the beam splitter is oriented so that the transmitted and reflected modes propagate perpendicularly, the two emerging wave packets will be separated by a spacelike distance, and a loophole-free Bell test could in principle be performed. The state, after propagation for times  $\tau_c$  and  $\tau_d$  along the two “arms”  $c$  and  $d$ , will become

$$|\Psi(\tau_c, \tau_d)\rangle = \frac{1}{\sqrt{2}}(e^{i\omega\tau_c}|1,0\rangle - e^{i\omega\tau_d}|0,1\rangle), \quad (2.4)$$

where  $\omega$  is the angular frequency of the light.

Let us now discuss how, in principle, the nonlocal properties of this state, identical in form to  $|\Psi_{-}\rangle$ , could be measured. To this end, let us consider the projectors

$$\frac{1}{2}[e^{i(\phi_c + \omega\tau_c)}|1\rangle + |0\rangle] \otimes [e^{-i(\phi_c + \omega\tau_c)}\langle 1| + \langle 0|], \quad (2.5)$$

$$\frac{1}{2}[e^{i(\phi_d + \omega\tau_d)}|1\rangle + |0\rangle] \otimes [e^{-i(\phi_d + \omega\tau_d)}\langle 1| + \langle 0|] \quad (2.6)$$

acting on the state in arms  $c$  and  $d$ , respectively. These projectors are Pegg-Barnett phase projectors [29] in a two-dimensional Hilbert space. Calculating the associated projection probabilities of the state  $|\Psi(\tau_c, \tau_d)\rangle$  one finds that

$$P(\phi_c) = P(\phi_d) = \frac{1}{2}, \quad P(\phi_c, \phi_d) = \frac{1}{2} \sin^2[(\phi_c - \phi_d)/2], \quad (2.7)$$

where, e.g.,  $P(\phi_c)$  denotes the probability of detecting the phase  $\phi_c$  in arm  $c$ , and  $P(\phi_c, \phi_d)$  denotes the joint probability of detecting the phase  $\phi_c$  in arm  $c$  and the phase  $\phi_d$  in arm  $d$ . The probabilities are *identical* to those encountered in Bohm and Aharonov’s version of the EPR paradox [28], and in Bell’s subsequent analysis of bounds on local hidden variables and quantum predictions [30]. This is simply because the state  $|\Psi\rangle$  is identical in form to the Bell state  $|\Psi_{-}\rangle$ .

There is nothing in quantum theory ruling out an experimental implementation of the projectors (2.5) and (2.6) as

classical measurement devices. Consequently, we have to assume that classical measurement devices exist that can implement them, just as we assume that there exist classical devices implementing, e.g., the projector  $|1\rangle\langle 1|$ . Therefore, one is led to the conclusion that quantum theory is nonlocal even for single particles. However, the sensitive time dependence of Eqs. (2.5) and (2.6) implies that an experimental configuration would have to be stable in time by a fraction of an optical period, and consequently in space by a fraction of a wavelength. Since  $|\Psi(\tau_c, \tau_d)\rangle$  is not an eigenstate of the free-space propagation Hamiltonian, it will be difficult to implement such an experiment. This is the main reason why the experiments proposed in Refs. [15] and [16] have not yet been attempted. The conventional (and experimentally simpler) tests of Bell's inequalities are based on two-particle states that are eigenstates of the free-space propagation Hamiltonian. We stress that going from single-particle to two-particle nonlocality tests simplifies things tremendously from an experimental point of view, but *changes nothing* from a fundamental point of view.

Peres [20] has pointed out that the projectors (2.5) and (2.6) do not commute with the total photon-number operator. He concludes that “nonlocal effects may thus appear for an initial state that contains a single particle, provided that the final state may contain two.” While the statement is correct, it should be an unsatisfactory answer to those who argue that single-particle states cannot be used to demonstrate nonlocality. The reason is that while the final (postmeasurement) state will contain two photons with probability 1/4, it will contain *no photon* with the same probability. If the first outcome is taken as an argument that our, and earlier, similar proposals are only a demonstration of multiphoton nonlocality in disguise, the same logic leads to the conclusion that the second outcome indicates that nonlocality can also be demonstrated with no particles. However, both “conclusions” are equally misleading, since they “explain” the nonlocal characteristics of the premeasurement state in terms of probabilities derived from the postmeasurement state.

The premeasurement state  $|\Psi\rangle$  is fully characterized by two binary, truth propositions [31]. Expressed operationally, they are (a) the sum of the photon numbers measured in the two arms is unity; and (b) the phase measured in one arm will always differ by  $\pi$  from the phase measured in the other arm. Since the phases measured at the two locations contain an element of reality (the  $\pi$  difference is certain) our proposed experiment avoids “the law of the excluded middle” [32]. The title of our paper is simply a summary of the consequences of truth propositions (a) and (b).

### III. SINGLE-PHOTON NONLOCALITY BASED ON RELATIVE PHASE

Now let us return to the experiment. The difficulties associated with single-particle nonlocality based on measurement of phase can be overcome by measuring relative phase instead of phase. To this end, consider the schematic setup depicted in Fig. 2. Incident on a polarizing beam splitter is a product state between a single-photon state and a coherent state with a mean photon number  $2|\alpha|^2$  (for simplicity, and

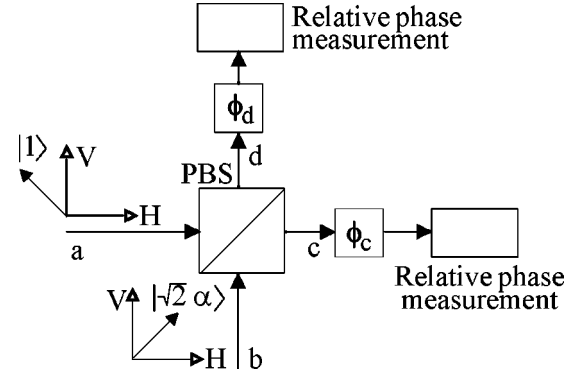

FIG. 2. A single-photon wave packet and a coherent state (prepared in matching spatiotemporal modes) impinge toward two ports of a polarizing beam splitter (PBS). The states are linearly polarized at  $45^\circ$  from the horizontal. At the end of the arms  $c$  and  $d$  the probabilities of the relative phases  $\phi_c$  and  $\phi_d$  of the spacelike separated state are measured.

without loss of generality, we shall assume that  $\alpha$  is real). The states are both linearly polarized at a direction  $45^\circ$  from the horizontal (in the following, vertical and horizontal polarizations will be denoted  $V$  and  $H$ , respectively). Expressing the state in a vertical-horizontal linear-polarization four-mode basis, the impinging state can be written as

$$\frac{1}{\sqrt{2}}(|1,0\rangle - |0,1\rangle) \otimes |\alpha, \alpha\rangle, \quad (3.1)$$

where we take the kets (left to right) to denote the modes  $aV$ ,  $aH$ ,  $bV$ , and  $bH$ . After the polarizing beam splitter, the state becomes

$$\frac{1}{\sqrt{2}}(|1, \alpha, \alpha, 0\rangle - |0, \alpha, \alpha, 1\rangle) \quad (3.2)$$

if expressed in the modes  $cV$ ,  $cH$ ,  $dV$ , and  $dH$ . In the absence of polarization dispersion (assume, e.g., that the wave packets propagate in vacuum or air), the state after mode  $c$  has evolved during time  $\tau_c$  and mode  $d$  during the time  $\tau_d$  will be

$$\frac{1}{\sqrt{2}}(e^{i\omega\tau_c}|1, e^{i\omega\tau_c}\alpha, e^{i\omega\tau_d}\alpha, 0\rangle - e^{i\omega\tau_d}|0, e^{i\omega\tau_c}\alpha, e^{i\omega\tau_d}\alpha, 1\rangle). \quad (3.3)$$

The exponential phase factors in Eq. (3.3) preserve the relative phase between the modes in each arm. In the absence of birefringence the relative phase between the two modes is a constant of motion.

To measure the relative phase between the states in arm  $c$  we introduce, in each two-mode energy manifold  $n > 0$ , the projector with eigenstate

$$|\xi^{(n)}(\phi)\rangle = \frac{1}{\sqrt{1+n/\alpha^2}} \left[ \frac{\sqrt{n}}{\alpha} |0, n\rangle + e^{i\phi} |1, n-1\rangle \right]. \quad (3.4)$$

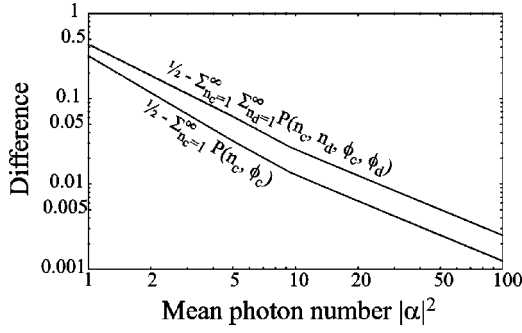

FIG. 3. The lower curve shows the difference  $1/2 - \sum_{n_c=1}^{\infty} P(n_c, \phi_c)$  as a function of the coherent state excitation  $\alpha^2$ . The probability  $P(n_c, \phi_c)$  is independent of  $\phi_c$ . Symmetry implies that the same relations hold for  $P(n_d, \phi_d)$ . The upper curve shows the maximum deviation (occurring for  $\phi_c - \phi_d = \pm \pi$ ) between the desired joint probability  $P(\phi_c, \phi_d)$  and the joint probability  $\sum_{n_c=1}^{\infty} \sum_{n_d=1}^{\infty} P(n_c, n_d, \phi_c, \phi_d)$ .

Note that this projector is time independent, and it is therefore also invariant under translations along the arm. In the  $n=0$  energy manifold, there is only one associated state, so in this manifold there exists no relative-phase-dependent projector. In all other manifolds the eigenstate  $|\xi^{(n)}(\phi)\rangle$  is similar in form to the eigenstates of the relative-phase operator [33]. The projection probabilities in the two arms on the states  $|\xi^{(n_c)}(\phi_c)\rangle$  and  $|\xi^{(n_d)}(\phi_d)\rangle$ , respectively, and the joint probability of detecting the relative phases  $\phi_c$  and  $\phi_d$  and the photon numbers  $n_c > 0$  and  $n_d > 0$  become

$$P(n_c, \phi_c) = \frac{e^{\alpha^2} \alpha^{2(n_c-1)}}{(1 + n_c/\alpha^2)(n_c-1)!},$$

$$P(n_d, \phi_d) = \frac{e^{\alpha^2} \alpha^{2(n_d-1)}}{(1 + n_d/\alpha^2)(n_d-1)!}, \quad (3.5)$$

$$P(n_c, n_d, \phi_c, \phi_d) = 2P(n_c, \phi_c)P(n_d, \phi_d) \sin^2[(\phi_c - \phi_d)/2].$$

The relative-phase probabilities  $P(n_c, \phi_c)$  and  $P(n_d, \phi_d)$  are independent of the settings of  $\phi_c$  and  $\phi_d$ . Summing, e.g.,  $P(n_c, \phi_c)$  over  $n_c$ , one finds that the probability of obtaining the relative phase  $\phi_c$  approaches  $1/2$  as the coherent state excitation increases. In Fig. 3 we have plotted the difference  $1/2 - \sum_{n_c=1}^{\infty} P(n_c, \phi_c)$  as a function of the mean photon number  $\alpha^2$  of the coherent state. In Fig. 4 we show how closely the projector defined by summing  $P(n_c, n_d, \phi_c, \phi_d)$  over  $n_c$  and  $n_d$  approximates the ideal projector for  $\alpha^2=3$  and  $\alpha^2=10$ . To quantify the deviation between the joint relative-phase probability and the joint phase-projector probability  $P(\phi_c, \phi_d)$ , we have also plotted the maximum difference between the two (that is, for  $\phi_c - \phi_d = \pm \pi$ ) in Fig. 3.

Before returning to the central question of the paper, namely, nonlocal properties of single particles, let us briefly discuss some technical aspects of our relative-phase proposal. One way to experimentally implement the proposal would be to make devices that, in each arm and each manifold  $n > 0$ , perform the transformation

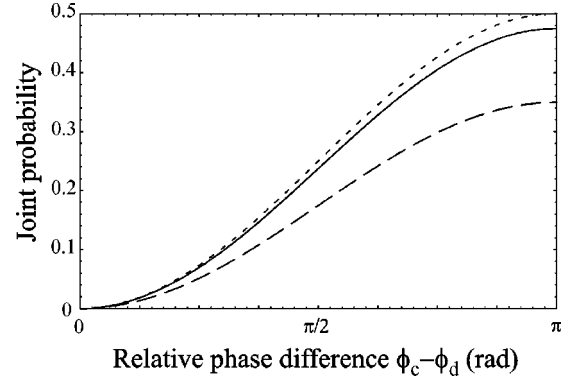

FIG. 4. The joint probability  $P(n_c, n_d, \phi_c, \phi_d)$  of detecting the two relative phases  $\phi_c$  and  $\phi_d$  as a function of the difference between them if the average excitation of the coherent state is  $\alpha^2 = 3$  (dashed line) and  $\alpha^2 = 10$  (solid line). The dotted line shows the desired form of the joint probability.

$$|m, n-m\rangle \langle \xi^{(n)}(0)|, \quad (3.6)$$

where  $0 < m \leq n$  [in this context it is irrelevant how all states orthogonal to  $|\xi^{(n)}(0)\rangle$  are transformed]. In this way, detection of the state  $|\xi^{(n)}(0)\rangle$  is converted to the much simpler (photon counting) detection of the state  $|m, n-m\rangle$ . In manifold  $n=1$  and  $n=2$  such transformations have been accomplished by the means of linear components, i.e., beam splitters and phase plates [34,35]. To make the projectors depend in the desired way on the relative phases  $\phi_c$  and  $\phi_d$ , variable birefringence components, such as birefringent liquid crystal cells, or birefringent wedges, could be inserted in the arms prior to the projective measurements [35]. In manifolds  $n > 2$  the transformations will require a nonlinear Hamiltonian [36], of the same level of technical difficulty as implementing a quantum optical controlled-NOT gate. Hence, our proposal is experimentally challenging at the moment, but it serves to demonstrate that single particles can indeed be used to show Bell-type correlations.

Now, let us go back to the interpretation of the proposed experiment. Clearly the measurement involves more than a single particle. However, all the nonlocal properties demonstrated by such an experiment are carried by a single particle. Hardy [27] suggested four criteria for unambiguous demonstration of single-photon nonlocality. Slightly abbreviated they are the following. (I) There should be a single-photon source and two quantum channels leading to spacelike separated measurement regions. In addition there may be classical channels between the measurement regions carrying classical information. (II) Photon detectors placed directly into the quantum channels will detect no more than one photon in the measured spatiotemporal modes. (III) If any of the quantum channels are blocked, no violation of locality can be observed. (IV) The results of the experiment violate locality. Our proposal meets all four criteria. The coherent state is a classical phase reference, copropagating with the single photon only to make the experiment less sensitive to measurement imperfections due to limited precision, or nonfundamental noise, in the time and space coordinates.

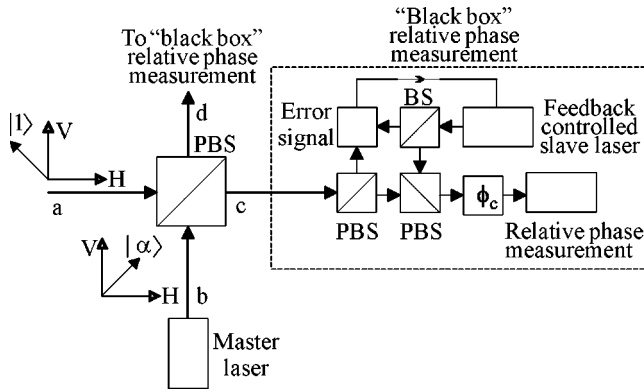

FIG. 5. A relative-phase measurement setup where the phase references are produced locally. Only one such “black-box” relative-phase meter is shown in full detail. The slave laser phase is regularly synchronized to the master laser phase using, e.g., a Pound-Drever servo loop. During a time short compared to the slave laser’s inverse linewidth, the relative phases can be measured locally in arms  $c$  and  $d$  without need for any master laser signal. The synchronization and measurement cycle can subsequently be repeated.

In principle, the coherent states could be produced locally. Since the phase stability of a laser is fundamentally limited only by the cold-cavity linewidth of the resonator and the energy stored in the cavity, there is no fundamental limit for how long two lasers can stay in synchronism [37]. Hence, *in principle*, two lasers could be adjusted (by a homodyne measurement) so that their respective phases coincided, then transported to two remote locations. Within a time proportional to the inverse linewidths, the lasers would stay synchronized and the experiment could be performed without a classical communication channel, that is, as a “black-box measurement.” Hence, the needed phase reference provided by the coherent states should be interpreted as internal states associated with the macroscopic measurement apparatuses implementing the projectors (2.5) and (2.6). That such an interpretation is both customary and legitimate has already been argued by Peres [20,38]. Enclosing the lasers in “black boxes,” such an experiment performed on a single photon in the state  $|\Psi\rangle$  could yield identical measurement statistics and a similar measurement configuration as spin analysis of two spin-1/2 particles in a singlet state.

In a more realistic scenario one can envision two individual (slave) lasers, one at the end of each arm, that are regularly synchronized by a short pulse of light from a centrally placed master laser (see Fig. 5). For a short time, the

classical channels are used to synchronize the slave lasers to the master laser and no measurements are done. Then the master laser is switched off and a series of single-photon relative-phase measurements, where the coherent states are produced locally, are made. The process is then repeated with a frequency higher than the laser linewidth (which is assumed to impose a more stringent requirement on the repetition frequency than the mechanical drift and vibrations of the experimental setup). This is essentially how “clock recovery” is performed in coherent optical communications systems. In these, local oscillator synchronization (albeit usually at much lower frequencies) is an integral part of the whole system. We see no fundamental reason why such a synchronization scheme could not be implemented at optical frequencies. In fact, more than ten years ago, such schemes were seriously being discussed in the context of coherent optical communication [39].

#### IV. SUMMARY

In conclusion, we have proposed an experiment that demonstrates nonlocal properties of a single particle. Our proposal is a single-particle analog to the two spin-1/2 particle experiment proposed by Bohm and Aharonov. Our experiment will be difficult to perform in practice, because most, if not all, detectors with a single-quantum sensitivity are particle (or energy) counters. Since single-particle nonlocality must not involve direct particle detection, but phase or relative-phase detection a unitary transformation must be used to convert these properties to properties measurable by a particle counter.

We have argued that the states providing the needed phase references should be ascribed to the macroscopic meter. At any rate these states carry no nonlocal characteristics. The inevitable conclusion must be that any spacelike separated state fulfilling Eqs. (2.1) and (2.2) has nonlocal properties, independent of what the kets represent. It is our hope that within the relatively near future the experiment we have proposed will be implemented experimentally.

#### ACKNOWLEDGMENTS

We thank Professor D. Greenberger, Professor A. Zeilinger, and Professor F. De Martini for making Ref. [24] available to us. This work was supported by the Swedish Foundation for Strategic Research (SSF), the European Union through program IST-1999-10243 (S4P), and the L.M. Ericsson Stiftelse för Främjande av Elektroteknisk Forskning.

[1] C.K. Hong and L. Mandel, Phys. Rev. A **31**, 2409 (1985).  
 [2] J.G. Rarity and P.R. Tapster, Phys. Rev. Lett. **64**, 2495 (1990).  
 [3] P.G. Kwiat, K. Mattle, H. Weinfurter, A. Zeilinger, A.V. Sergienko, and Y. Shih, Phys. Rev. Lett. **75**, 4337 (1995).  
 [4] F. De Martini, G. Di Giuseppe, and M. Marrocco, Phys. Rev. Lett. **76**, 900 (1996).  
 [5] B. Lounis and W.E. Moerner, Nature (London) **407**, 491 (2000).

[6] C. Brunel, B. Lounis, P. Tamarat, and M. Orrit, Phys. Rev. Lett. **83**, 2722 (1999).  
 [7] L. Fleury, J.M. Segura, G. Zumofen, B. Hecht, and U.P. Wild, Phys. Rev. Lett. **84**, 1148 (2000).  
 [8] J. Kim, O. Benson, H. Kan, and Y. Yamamoto, Nature (London) **397**, 500 (1999).  
 [9] C. Kurtsiefer, S. Mayer, P. Zarda, and H. Weinfurter, Phys. Rev. Lett. **85**, 290 (2000).

- [10] R. Brouri, A. Beveratos, J.-P. Poizat, and P. Grangier, *Opt. Lett.* **25**, 1294 (2000).
- [11] P. Michler, A. Imamoglu, M.D. Mason, P.J. Carson, G.F. Strouse, and S.K. Buratto, *Nature (London)* **406**, 968 (2000).
- [12] P. Michler and A. Kiraz, *Science* **290**, 2282 (2000).
- [13] C. Santori, M. Pelton, G. Solomon, Y. Dale, and Y. Yamamoto, *Phys. Rev. Lett.* **86**, 1502 (2001).
- [14] V. Zwiller, H. Blom, N. Panev, P. Jonsson, S. Jeppesen, T. Tsegaye, E. Goobar, M.-E. Pistol, L. Samuelson, and G. Björk, *Appl. Phys. Lett.* **78**, 2476 (2001).
- [15] S.M. Tan, D.F. Walls, and M.J. Collett, *Phys. Rev. Lett.* **66**, 252 (1991).
- [16] L. Hardy, *Phys. Rev. Lett.* **73**, 2279 (1994).
- [17] M. Czachor, *Phys. Rev. A* **49**, 2231 (1994).
- [18] D. Home and G.S. Agarwal, *Phys. Lett. A* **209**, 1 (1995).
- [19] M. Revzen and A. Mann, *Found. Phys.* **26**, 847 (1996).
- [20] A. Peres, *Phys. Rev. Lett.* **74**, 4571 (1995).
- [21] C.C. Gerry, *Phys. Rev. A* **53**, 4583 (1996).
- [22] M. Michler, H. Weinfurter, and M. Żukowski, *Phys. Rev. Lett.* **84**, 5457 (2000).
- [23] D.M. Greenberger, M.A. Horne, and A. Zeilinger, *Phys. Rev. Lett.* **75**, 2064 (1995).
- [24] D.M. Greenberger, M.A. Horne, and A. Zeilinger, in *Quantum Interferometry II*, edited by F. De Martini, G. Deurdo, and Y. Shih (VCH, Weinheim 1997).
- [25] E. Santos, *Phys. Rev. Lett.* **68**, 894 (1992); S.M. Tan, D.F. Walls, and M.J. Collett, *ibid.* **66**, 895 (1992).
- [26] L. Vaidman, *Phys. Rev. Lett.* **75**, 2063 (1995).
- [27] L. Hardy, *Phys. Rev. Lett.* **75**, 2065 (1995).
- [28] D. Bohm and Y. Aharonov, *Phys. Rev.* **108**, 1070 (1957).
- [29] D.T. Pegg and S.M. Barnett, *Europhys. Lett.* **6**, 483 (1988).
- [30] J.S. Bell, *Physics (Long Island City, N.Y.)* **1**, 195 (1964).
- [31] A. Zeilinger, *Found. Phys.* **29**, 631 (1999).
- [32] H.J. Bernstein, D.M. Greenberger, M.A. Horne, and A. Zeilinger, *Phys. Rev. A* **47**, 78 (1993).
- [33] A. Luis and L.L. Sánchez-Soto, *Phys. Rev. A* **48**, 4702 (1993).
- [34] P. Grangier, G. Roger, and A. Aspect, *Europhys. Lett.* **1**, 173 (1986).
- [35] A. Trifonov, T. Tsegaye, G. Björk, J. Söderholm, E. Goobar, M. Atatüre, and A.V. Sergienko, *J. Opt. B: Quantum Semiclassical Opt.* **2**, 105 (2000).
- [36] G. Björk and J. Söderholm, *J. Opt. B: Quantum Semiclassical Opt.* **1**, 315 (1999).
- [37] A.L. Schawlow and C.H. Townes, *Phys. Rev.* **112**, 1940 (1958).
- [38] A. Peres, *Quantum Theory: Concepts and Methods* (Kluwer, Dordrecht, 1993), Chap. 12.
- [39] K. Kikuchi, *Electron. Commun. Jpn., Part 2: Electron.* **74**, 1 (1991); B. Wandernoth, *Electron. Lett.* **27**, 1692 (1991); D.F. Hornbachner, M.A. Schreiblehner, W.R. Leeb, and A.L. Scholtz, *Proc. SPIE* **1635**, 10 (1992).