

# Generalized coherent states for systems with degenerate energy spectra

Ronald F. Fox and Mee Hyang Choi

*School of Physics, Center for Nonlinear Science, Georgia Institute of Technology, Atlanta, Georgia 30332-0430*

(Received 29 March 2001; published 12 September 2001)

A construction of Gaussian Klauder coherent states for systems with degenerate energy spectra is presented. Of special interest are the cases of truly accidental degeneracy that do not arise from a hidden or explicit symmetry. This is the case for a particle in a two-dimensional square box. In this case, the degeneracy results from the number of different ways an integer can be expressed as the sum of two squares. It is shown how to manage this situation and produce generalized coherent states that can mimic classical particle behavior for many collisions with the box walls.

DOI: 10.1103/PhysRevA.64.042104

PACS number(s): 03.65.Ge

## I. INTRODUCTION

In two recent papers, Gaussian Klauder coherent states were constructed for Rydberg atoms [1], the harmonic oscillator [2], the planar rotor [2], and a particle in a one-dimensional box [2]. In each of these cases, it was possible to select parameters so that the quantum coherent state behaved like the corresponding classical object for long periods of time. In the Rydberg-atom case, this meant that the wave packet for the electron executed Keplerian orbits around the atomic nucleus for many periods while remaining a highly localized object [1]. Aspects of this behavior for Rydberg atoms, including revivals and fractional revivals, were experimentally observed earlier by Mallalieu and Stroud [3], and explained with Gaussian wave packets by Nauenberg [4]. The Gaussian Klauder coherent states provide a special class of Gaussian wave packets that support a resolution of the identity operator (they are actually overcomplete), and evolve in a very simple way under the action of the system Hamiltonian. When the Klauder construction was initially applied [1], delocalization in the azimuthal angle occurred rapidly. This led to a Gaussian extension of the Klauder method [1], and to generalized coherent states that maintain their initially compact structures for long times.

A key property needed for the direct application of the Klauder construction procedure [5] is a bounded finite quantum system with a discrete spectrum. The Gaussian generalization [1,2] appears to work for any Hamiltonian with this property. However, a degenerate energy spectrum raises difficulties in some systems. Crawford [6] recently considered this, and proposed a solution based on the Perelomov construction [7]. This approach depends on an underlying symmetry of the Hamiltonian that is responsible for the degeneracy. The solution proposed in this paper works for this case too, but also covers accidental degeneracy for which no underlying symmetry exists.

Generalized coherent states are of importance because they clarify quantum-classical correspondence issues, and they do so by providing a means for the construction of Husimi-Wigner distributions [8–10]. These distributions are non-negative quantum probability distributions with quantitative analogs in classical phase space, where their correspondents are initially Gaussian ensembles. One important consequence of this perspective was to show that the initial rate of growth of quantum covariances determines the corre-

sponding classical, local Lyapunov exponent when the classical dynamics is chaotic [8], i.e., that the classical, local Lyapunov exponent is a quantum signature of classical chaos.

In Sec. II of this paper, a brief review of the Gaussian Klauder coherent states construction is given. The incorporation of energy degeneracy is presented. In Sec. III, an application to a particle in a two-dimensional (2D) square box is made. Here the degeneracy results from the number of different ways an integer can be expressed as the sum of two squares. A bit of the underlying number theory is reviewed. The initial try at a Gaussian Klauder coherent state does not work. A further modification of the Gaussian approach is needed and developed. Numerical results exhibiting long-time quantum behavior corresponding with a classical particle bouncing off of the box walls are given.

## II. GAUSSIAN KLAUDER COHERENT STATES

Let the Hamiltonian  $H$  have eigenstates and eigenvalues satisfying

$$H|n\rangle = E_n|n\rangle = \hbar\omega e_n|n\rangle, \quad (1)$$

so that the  $e_n$ 's are dimensionless for the energy scale  $\hbar\omega$ , and wherein  $e_0 < e_1 < e_2 < \dots$  [5]. So far, it is implicitly assumed that the spectrum is nondegenerate. The Gaussian Klauder coherent state is defined by [1,2]

$$|G, n_0, \phi_0\rangle = \sum_{n=0}^{\infty} \frac{\exp\left[-\frac{(n-n_0)^2}{4\sigma^2}\right]}{\sqrt{N(n_0)}} e^{ie_n\phi_0}|n\rangle, \quad (2)$$

where

$$N(n_0) = \sum_{n=0}^{\infty} \exp\left[-\frac{(n-n_0)^2}{2\sigma^2}\right], \quad (3)$$

which guarantees normalization:

$$\langle G, n_0, \phi_0 | G, n_0, \phi_0 \rangle = 1. \quad (4)$$

Both  $n_0$  and  $\phi_0$  are  $c$ -number parameters of the state, and  $\sigma$  determines the width of the Gaussian. Clearly, as  $n_0 \rightarrow \infty$ ,  $N(n_0) \rightarrow \sqrt{2\pi\sigma^2}$ ; however, for finite  $n_0$ , and because the summation is discrete,  $N(n_0)$  is not expressible in a closed

form. If the evolution operator for time  $t$  built from  $H$  is applied to the generalized coherent state in Eq. (2), then the effect is that  $\phi_0$  is shifted linearly in time to  $\phi_0 - \omega t$  when Eq. (1) is applied. This is one of the attractive features of Klauder coherent states called ‘‘temporal stability’’ [5]. By making  $\sigma$  sufficiently small, i.e., less than 1, the state defined in Eq. (2) is essentially a pure energy eigenstate. As such, its structure in the corresponding classical phase space of generalized coordinates and conjugate momenta is not localized. As  $\sigma$  increases so that the superposition of states involves more and more energy eigenstates, the structure of the state in phase space becomes more and more localized, up to a point. Thus the choice of  $\sigma$  is dictated by the desire to start the state as localized as possible in phase space, subject to the constraints of the Heisenberg uncertainty principle [8].

Using the limit identity [5]

$$\lim_{\Phi \rightarrow \infty} \frac{1}{2\Phi} \int_{-\Phi}^{\Phi} d\phi_0 e^{i(e_n - e_{n'})\phi_0} = \delta_{nn'}, \quad (5)$$

and giving  $n_0$  a domain of minus infinity to plus infinity rather than just the positive values, leads to a resolution of the identity operator [1,2,5],

$$\int_{-\infty}^{\infty} dn_0 \lim_{\Phi \rightarrow \infty} \frac{1}{2\Phi} \int_{-\Phi}^{\Phi} d\phi_0 K(n_0) |G, n_0, \phi_0\rangle \langle G, n_0, \phi_0| = \mathbf{1}, \quad (6)$$

provided  $K(n_0)$ , the Klauder kernel, is given by

$$K(n_0) = \frac{N(n_0)}{\sqrt{2\pi\sigma^2}}. \quad (7)$$

Completeness follows from Eq. (5). For any fixed value of  $n_0$ , it follows that

$$\begin{aligned} |n\rangle &= \sqrt{N(n_0)} \exp\left[\frac{(n-n_0)^2}{4\sigma^2}\right] \lim_{\Phi \rightarrow \infty} \frac{1}{2\Phi} \\ &\times \int_{-\Phi}^{\Phi} d\phi_0 e^{-ie_n\phi_0} |G, n_0, \phi_0\rangle. \end{aligned} \quad (8)$$

This is overcompleteness if  $n_0$  is varied. It is a characteristic of harmonic oscillator coherent states, su(2) generalized coherent states [8] and Klauder coherent states [5].

Degeneracy in the energy spectrum impacts the applicability of Eq. (5), which is applicable only for a nondegenerate spectrum. Suppose that the energy eigenvalue  $e_n$  is degenerate with a degeneracy  $d_n$ . Pick an orthonormal basis for this degeneracy set, and denote these states by  $|n, p\rangle$  where  $p$  ranges from 0 to  $d_n - 1$ . If  $d_n = 1$ , then  $|n, 0\rangle$  is simply the state  $|n\rangle$  used above. For each  $n$ , introduce the phase  $\eta_n$  that ranges over  $[0, 2\pi]$ . The nondegenerate state  $|n\rangle$  is extended to the degenerate state superposition  $|n, d_n\rangle$  by the definition

$$|n, d_n\rangle = \frac{1}{\sqrt{d_n}} \sum_{p=0}^{d_n-1} e^{ip\eta_n} |n, p\rangle. \quad (9)$$

For the nondegenerate case, this state reduces to  $|n\rangle$ . Thus, even though an  $\eta_n$  is introduced for every  $e_n$ , even the nondegenerate  $e_n$ 's, it has no influence in the nondegenerate cases. Denote the countably infinite set of  $\eta_n$ 's by the vector  $\boldsymbol{\eta}$ . The generalized Gaussian Klauder coherent states for degenerate spectra are defined by

$$|G, n_0, \phi_0, \boldsymbol{\eta}\rangle = \sum_{n=0}^{\infty} \frac{\exp\left[-\frac{(n-n_0)^2}{4\sigma^2}\right]}{\sqrt{N(n_0)}} e^{ie_n\phi_0} |n, d_n\rangle. \quad (10)$$

With the normalization picked in Eq. (9),  $N(n_0)$  in Eq. (10) is still defined as in Eq. (3). The resolution of the identity operator generalizes to

$$\begin{aligned} &\int_{-\infty}^{\infty} dn_0 \lim_{\Phi \rightarrow \infty} \frac{1}{2\Phi} \\ &\times \int_{-\Phi}^{\Phi} d\phi_0 K(n_0) \prod_{j=0}^{\infty} \frac{1}{2\pi} \\ &\times \int_0^{2\pi} d\eta_j |G, n_0, \phi_0, \boldsymbol{\eta}\rangle \langle G, n_0, \phi_0, \boldsymbol{\eta}| \\ &= \mathbf{1}. \end{aligned} \quad (11)$$

Once again, if the eigenstate is nondegenerate, the corresponding  $\eta_j$  integration has no effect other than to produce a multiplicative factor of 1. The analog of the completeness relation in Eq. (8) is

$$\begin{aligned} |n, m\rangle &= \sqrt{N(n_0)} \exp\left[\frac{(n-n_0)^2}{4\sigma^2}\right] \lim_{\Phi \rightarrow \infty} \frac{1}{2\Phi} \\ &\times \int_{-\Phi}^{\Phi} d\phi_0 e^{ie_n\phi_0} \frac{\sqrt{d_n}}{2\pi} \\ &\times \int_0^{2\pi} d\eta_n e^{-im\eta_n} |G, n_0, \phi_0, \boldsymbol{\eta}\rangle. \end{aligned} \quad (12)$$

As will be seen in Sec III, further modification of the Gaussian construction is needed in order to obtain an initially compact state in phase space for a particle in a 2D square box.

### III. A PARTICLE IN A 2D SQUARE BOX

The Hamiltonian for a particle of mass  $M$  in a 2D square box with infinite potential walls is

$$H = \frac{\mathbf{p}^2}{2M}, \quad (13)$$

where  $\mathbf{p}$  is the momentum operator and  $M$  is the mass. Place one corner of the box at the origin of coordinates, and let the rest of the box be in the positive quadrant. Let the length of a box side be  $a$ . The energy eigenvalues are given by

$$E_{n,m} = \frac{\hbar^2 \pi^2}{2Ma^2} (n^2 + m^2). \quad (14)$$

There is an obvious degeneracy that has its origin in the square symmetry of the problem, i.e., the degeneracy created by interchanging  $n$  and  $m$ . However, there is an erratic degeneracy associated with the number of ways an integer can be expressed by the sum of two squares that is genuinely accidental (unlike the “accidental” degeneracy of the hydrogen atom that stems from an extra conserved quantity, and corresponding symmetry, given by the Runge-Lenz vector). In Eq. (10) the index  $n$  corresponds to the dimensionless energy eigenvalue  $e_n$ , and must not be confused with the  $n$  and  $m$  above in  $E_{n,m}$ . These doubly indexed energy eigenvalues must first be converted to a singly indexed  $e_n$  before Eq. (10) can be implemented. This is easily achieved by ordering the  $E_{n,m}$ ’s by size.

The problem of expressing an integer as the sum of two squares is an old problem in number theory [11]. There are precursors in the *Arithmetic* of Diophantus around 250 A.D.; the correct answer to the question was first given by Albert Girard in 1625, but the first known proofs are those of Euler in 1749 [11]. A crucial ingredient is Fibonacci’s identity of 1202 that the product of two sums of two squares is itself the sum of two squares:

$$(a^2 + b^2)(c^2 + d^2) = (ac + bd)^2 + (ad - bc)^2. \quad (15)$$

This enables one to build up results from multiplicative factors that are the sums of two squares. It is elementary to show that any number that is of the form  $4k + 3$  cannot be the sum of two squares [11]. All others can. If a number contains a prime factor of the form  $4k + 3$ , then it must contain it to an even power if it is to be expressible as the sum of two squares (an even power has the form  $4k' + 1$  for some  $k'$ , and is all right). Thus a number  $N$  is expressible as the sum of two squares if and only if any prime factor of  $N$  of the form  $4k + 3$  divides  $N$  an even number of times.

How many ways  $N$  can be expressed as a sum of two squares was worked out by Legendre in the early 1800s [11]. Let  $D_1$  denote the number of divisors of  $N$  of the form  $4k + 1$ , and let  $D_3$  denote the number of divisors of  $N$  of the form  $4k + 3$ . The number of representations of  $N$  as the sum of two squares is  $4(D_1 - D_3)$ . Note, for example, that if  $N$  has a prime factor of the form  $4k + 1$ , all powers of this factor are also of the form  $4k' + 1$ , but with different values of  $k'$ . The product of  $4k + 1$  and  $4k' + 1$  is also of the same form. Moreover, the product of  $4k + 3$  and  $4k' + 3$  has the form of  $4k'' + 1$  while the product of  $4k + 3$  and  $4k' + 1$  has the form of  $4k'' + 3$ . Thus the determination of  $D_1$  and  $D_3$  is nontrivial for large  $N$ . The factor of 4 in the Legendre rule allows for positive and negative integers in the sum of squares. The negative possibilities are excluded in the eigenvalue formula of Eq. (14).

In numerically constructing the generalized Gaussian Klauder coherent states for the particle in a 2D square box according to Eq. (10), it is necessary to determine the degeneracies of the energy eigenvalues used. For those states that are degenerate (actually, each state is at least doubly degenerate because of the square symmetry), the phase angle  $\eta$  is chosen from  $[0, 2\pi]$  at random.

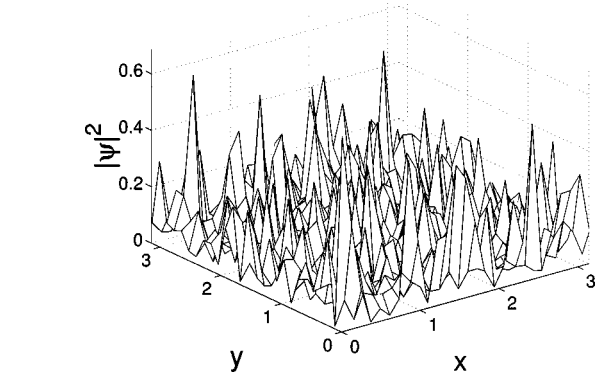

FIG. 1. Gaussian Klauder coherent state with a single Gaussian form factor. The parameter values are  $a = \pi$ ,  $n_0 = 10\,000$ , and  $\sigma = 5$ . No localization is discernable.

When a straightforward attempt to implement Eq. (10) for this case is made, the result is not a highly localized initial state as it was in the earlier constructions [1,2]. This is because the degeneracy caused by equal sums of two squares can involve  $n$ ’s and  $m$ ’s in  $E_{n,m}$  that are very different from  $n_0$ , even though the  $n$  in  $e_n$  is kept close to  $n_0$  by the Gaussian form factor in Eq. (10). This means that the corresponding eigenfunctions contribute components in the  $x$  and  $y$  variables that have wavelengths varying over a large range of scale. The result is that the wave packet is not localized. This is exhibited in Fig. 1 for the parameters  $n_0 = 10\,000$  and  $\sigma = 5$ , with the length of the side of the box given by  $a = \pi$ .

To get around this problem, a Gaussian form factor for each index  $n$  and  $m$  in  $E_{n,m}$  can be introduced. This can be done so that all of the properties of Gaussian Klauder coherent states are retained, as they are by Eq. (10). Begin by introducing a dimensionless energy scale given by  $E_{m,n} = \hbar\omega e_{n,m}$ . Suppose that  $e_{n,m}$  is degenerate, with a degeneracy  $d_{n,m}$ . Let the set of degenerate states be made orthonormal and denote them by  $|n,m,p\rangle$  for  $p = 0$  to  $d_{n,m} - 1$ . Also introduce the phases  $\eta_{n,m}$  that range over  $[0, 2\pi]$ . The degenerate state superposition  $|n,m,d_{n,m}\rangle$  is defined by

$$|n,m,d_{n,m}\rangle = \frac{1}{\sqrt{d_{n,m}}} \sum_{p=0}^{d_{n,m}-1} e^{ip\eta_{n,m}} |n,m,p\rangle. \quad (16)$$

Now replace Eq. (10) with

$$\begin{aligned} & |G, m_0, n_0, \phi_0, \boldsymbol{\eta}\rangle \\ &= \sum_{n=0}^{\infty} \sum_{m=0}^{\infty} \frac{\exp\left[-\frac{(n-n_0)^2}{4\sigma^2} - \frac{(m-m_0)^2}{4\sigma^2}\right]}{\sqrt{N(m_0, n_0)}} \\ & \quad \times e^{ie_{n,m}\phi_0} |n,m,d_{n,m}\rangle, \end{aligned} \quad (17)$$

where the doubly countable infinity of  $\eta_{n,m}$ ’s is represented by the vector  $\boldsymbol{\eta}$ . The normalization of this state implies

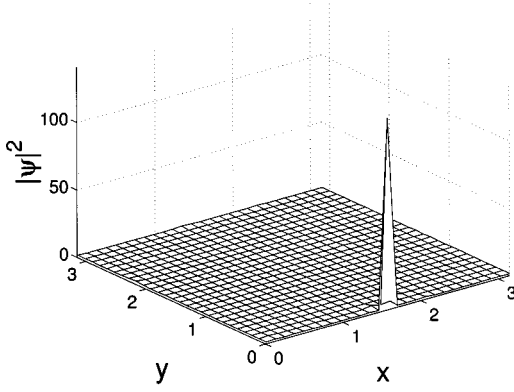

FIG. 2. Gaussian Klauder coherent state with a double Gaussian form factor. The parameter values are  $a=\pi$ ,  $n_0=6500$ ,  $m_0=6500$ , and  $\sigma=23$ . A highly localized initial state can be seen.

$$N(m_0, n_0) = \sum_{n=0}^{\infty} \sum_{m=0}^{\infty} \exp\left[-\frac{(n-n_0)^2}{2\sigma^2} - \frac{(m-m_0)^2}{2\sigma^2}\right], \quad (18)$$

which generalizes Eq. (3). Temporal stability remains guaranteed because the action of the evolution operator for time  $t$ , constructed with the Hamiltonian of Eq. (13) on the state in Eq. (17), causes  $\phi$  to become  $\phi - \omega t$  when  $E_{m,n} = \hbar \omega e_{n,m}$  is used. The resolution of the identity becomes

$$\begin{aligned} & \int_{-\infty}^{\infty} dn_0 \int_{-\infty}^{\infty} dm_0 \lim_{\Phi \rightarrow \infty} \frac{1}{2\Phi} \\ & \times \int_{-\Phi}^{\Phi} d\phi_0 K(n_0, m_0) |G, n_0, m_0, \phi_0, \boldsymbol{\eta}\rangle \\ & \times \langle G, n_0, m_0, \phi_0, \boldsymbol{\eta}| \\ & = 1, \end{aligned} \quad (19)$$

where  $K(n_0, m_0)$  is given by

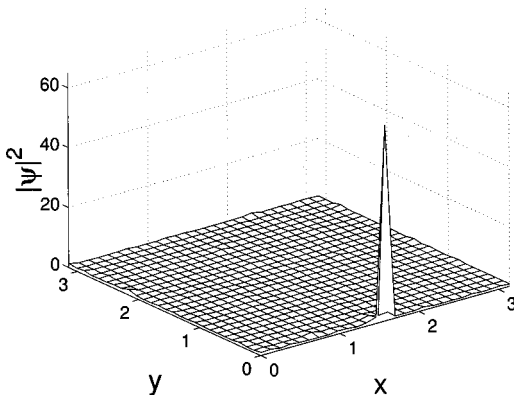

FIG. 3. This has the same initial wave packet as in Fig. 2. The wave packet has made one complete round-trip of the box, in a counterclockwise direction.

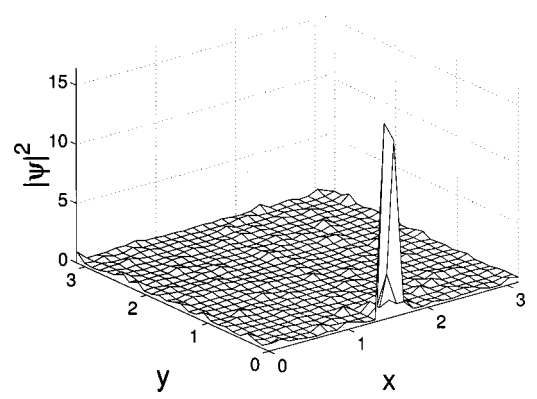

FIG. 4. This has the same initial wave packet as in Fig. 2. The wave packet has made three complete round trips of the box in a counterclockwise direction.

$$K(n_0, m_0) = \frac{N(n_0, m_0)}{2\pi\sigma^2}. \quad (20)$$

Overcompleteness may be expressed by

$$\begin{aligned} |n, m, p\rangle &= \sqrt{N(n_0, m_0)} \exp\left[\frac{(n-n_0)^2}{4\sigma^2} + \frac{(m-m_0)^2}{4\eta^2}\right] \\ & \times \lim_{\Phi \rightarrow \infty} \frac{1}{2\Phi} \int_{-\Phi}^{\Phi} d\phi_0 e^{-ie_{n,m}\phi_0} \frac{\sqrt{d_{n,m}}}{2\pi} \\ & \times \int_0^{2\pi} d\eta_{n,m} e^{-ip\eta_{n,m}} |G, n_0, m_0, \phi_0, \boldsymbol{\eta}\rangle. \end{aligned} \quad (21)$$

In Eq. (18) both variances are equal, but this is not necessary. It is now clear that those degenerate states with  $n$ 's and  $m$ 's further than a few  $\sigma$ 's from  $n_0$  and  $m_0$ , respectively, will contribute very little to the wave packet. Consequently, an initially well localized state is possible.

Figure 2 shows the initial wave packet probability for a particle in a 2D square box coherent state that initially has the vast majority of the coordinate probability located at the

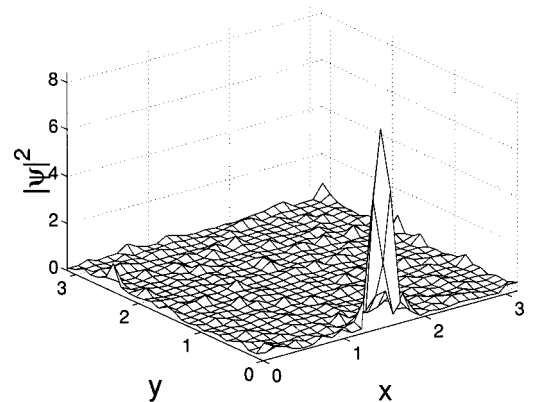

FIG. 5. This has the same initial wave packet as in Fig. 2. The wave packet has made five complete round-trips of the box in a counterclockwise direction.

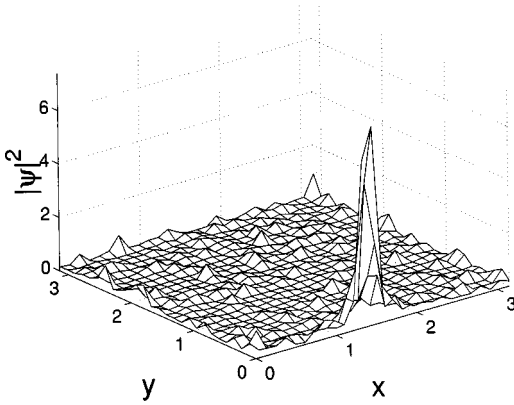

FIG. 6. This has the same initial wave packet as in Fig. 2. The wave packet has made seven complete round-trips of the box in a counterclockwise direction. Partial delocalization can be seen, and the peak height has decreased substantially.

middle of an edge of the box. The length of the side of the box,  $a$ , has been taken to be  $\pi$ . Both  $n_0$  and  $m_0$  are 6500, and the  $\sigma$  for each is 23. The probability profile changes very little as successive contacts with the edges of the box are made as the packet moves in a counterclockwise direction. Figures 3–6 show the condition of the wave packet after one, three, five, and seven completed round-trips, respectively. It is clear that localization is partially lost by the seventh round trip in this case. Nevertheless, if the expected value for the position is computed for this wave packet even after seven round trips, the value is still in very close agreement with the classical position. By increasing  $n_0$  and  $m_0$ , as well as  $\sigma$ , the initial state may be made sharper and it will remain sharper for longer. However, computational demands will increase as well. For fixed  $n_0$  and  $m_0$ , an increase in  $\sigma$  will make the initial state more localized but the delocalization rate will also increase. To compensate for this both  $n_0$  and  $m_0$  must be increased.

By changing parameter values to  $n_0=6500$  but  $m_0=5000$  and  $\sigma_n=23$  while  $\sigma_m=20$ , a wave packet is created that is initially in a corner, and directed so that it misses the corner diagonally across the square. The wave packet makes successive contacts with the sides of the square and maintains its localization even after reflections from the sides. Figure 7 shows the corresponding classical trajectory, wherein the initial velocity components in the  $x$  and  $y$  directions are determined from the initial quantum-mechanical group velocities in these directions. The positional correspondence between the classical trajectory and the wave packet's positional expectation values are quantitatively very accurate and cannot be distinguished in this figure.

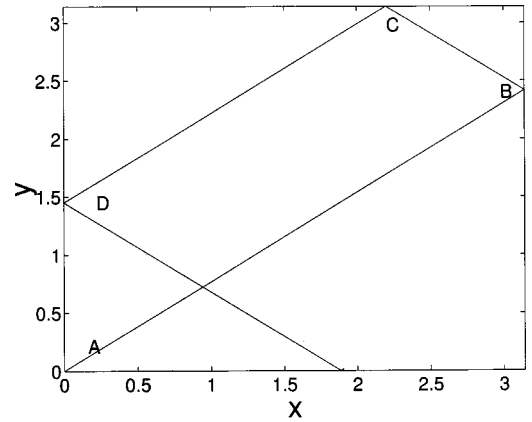

FIG. 7. A classical trajectory corresponding to the motion of the wave packet with parameters  $a=\pi$ ,  $n_0=6500$ ,  $m_0=5000$ ,  $\sigma_n=23$ , and  $\sigma_m=20$  is shown. The impacts with the edges occur at corresponding positions. A plot of the corresponding positional expectation value for the quantum wave packet is indistinguishable.

#### IV. CONCLUDING REMARKS

A method for dealing with degeneracy in the energy spectrum while constructing Gaussian Klauder coherent states has been presented. In the case of a two-dimensional box, the degeneracy is accidental and a naive approach does not produce an initially localized wave packet. This problem is overcome by modifying the construction. Since the Hamiltonian for a particle in a two-dimensional box is separable, one could simply attempt to use the direct product of Gaussian Klauder coherent states for each Cartesian axis as a candidate for the solution to the two-dimensional problem. Unfortunately, the energy factors in such a construction do not work properly except in the very special case of trajectories that make  $45^\circ$  impacts with the sides. In all other cases, the energy of the particle along the two Cartesian axes is different, and exchanges between the axes with each collision. This messes up such a construction. Instead, in Eq. (17) a construction that works well quantitatively is given. This technique can be applied to many other multidimensional problems.

Gaussian Klauder coherent states provide a means to construct Husimi-Wigner states that have a direct correspondence to classical ensembles in classical phase space. Such states enhance our ability to study quantum-classical correspondence and especially quantum signatures of classical chaos [8].

#### ACKNOWLEDGMENT

This work was supported by National Science Foundation Grant No. PHY-9819646.

- [1] R. F. Fox, Phys. Rev. A **59**, 3241 (1999).  
 [2] R. F. Fox and M. H. Choi, Phys. Rev. A **61**, 032107 (2000).  
 [3] M. Mallalieu and C. R. Stroud, in *Coherent States: Past, Present and Future*, edited by D. H. Feng, J. R. Klauder, and M. R. Strayer (World Scientific, Singapore, 1994),

pp. 301–314.

- [4] M. Nauenberg, Phys. Rev. A **40**, 1133 (1989).  
 [5] J. R. Klauder, J. Phys. A **29**, L293 (1996).  
 [6] M. G. A. Crawford, Ph.D. thesis, University of Waterloo, Waterloo, Ontario, Canada, 2000; Phys. Rev. A **61**,

- 012104 (2000).
- [7] A. M. Perelomov, *Generalized Coherent States and Their Applications* (Springer-Verlag, London, 1986).
- [8] R. F. Fox and T. C. Elston, Phys. Rev. E **49**, 3683 (1994); **50**, 2553 (1994).
- [9] S.-J. Chang and K.-J. Shi, Phys. Rev. A **34**, 7 (1986).
- [10] K. Nakamura, A. R. Bishop, and A. Shudo, Phys. Rev. B **39**, 12 422 (1989).
- [11] H. Davenport, *The Higher Arithmetic, An Introduction to the Theory of Numbers* (Dover, New York, 1983), Chap. V.