

Quantum remote control: Teleportation of unitary operations

S. F. Huelga,* J. A. Vaccaro, and A. Chefles

Department of Physical Sciences, University of Hertfordshire, Hatfield AL10 9AB, England

M. B. Plenio

Optics Section, The Blackett Laboratory, Imperial College, London SW7 2BW, England

(Received 26 May 2000; published 15 March 2001)

We consider the implementation of an arbitrary unitary operation U upon a distant quantum system. This teleportation of U can be viewed as *quantum remote control*. We investigate protocols that achieve this using local operations, classical communication, and shared entanglement. Lower bounds on the necessary entanglement and classical communication are determined using causality and the linearity of quantum mechanics. We examine in particular detail the resources required if the remote control is to be implemented as a classical black box. Under these circumstances, we prove that the required resources are, necessarily, those needed for implementation by bidirectional state teleportation.

DOI: 10.1103/PhysRevA.63.042303

PACS number(s): 03.67.Hk, 03.65.Ta

Much of the current fascination with quantum information processing derives from the properties of entanglement [1]. On one hand, entanglement can give rise to nonlocal correlations that defy explanation in terms of local, realistic theories [2], but, on the other hand, it can also be used as a resource. In fact, entanglement is the key ingredient in quantum state teleportation, which allows one to transmit an unknown quantum state despite the fact that it is impossible to determine this state. Quantum state teleportation [3] can be linked directly to various interrelated principles of quantum information processing, such as the impossibility of superluminal communication, the nonincrease of entanglement under local operations and classical communication [1], and the no-cloning theorem [4]. However, these theorems deal with quantum states, and it is an interesting question to study instead quantum operations. In this paper, we therefore examine the issue of teleportation, not of an unknown quantum state, but rather of an unknown quantum operation on a qubit. Such a procedure would function in a manner similar to that of a remote control apparatus, and so we shall also refer to it as *quantum remote control*.

The most general scenario for the teleportation of an arbitrary unitary operation is depicted in Fig. 1. One party, Alice, possesses a physical system C , which we shall refer to as the *control*. The control contains information describing a unitary operation U upon the state of a qubit, and is itself a quantum system. The control state corresponding to the unitary operation U will be denoted by $|U\rangle_C$. Her colleague Bob has a qubit β prepared in the state $|\psi\rangle_\beta$. The aim is to devise a physical procedure that effects the transformation $|\psi\rangle_\beta \mapsto U|\psi\rangle_\beta$ for every initial state $|\psi\rangle_\beta$ and every unitary operation U . The most general such procedure can be represented by a completely positive, linear, trace preserving map on the set of density operators for the combined $C\beta$ system. Any such map has a unitary representation \mathcal{T} involving ancillary systems. We shall denote the state of the ancilla at

Alice's and Bob's laboratories by $|\chi\rangle_{AB}$ and we furthermore assume that the unitary operation U is applied only once. Then the teleportation operation has the general form

$$\mathcal{T}[|\chi\rangle_{AB} \otimes |U\rangle_C \otimes |\psi\rangle_\beta] = |\Phi(U, \chi)\rangle_{ABC} \otimes (U|\psi\rangle_\beta). \quad (1)$$

In the following we investigate some of the properties of \mathcal{T} . In particular, we derive lower bounds on the amount of nonlocal resources that are needed to implement \mathcal{T} using only local operations and classical communication. The unitary teleportation operator \mathcal{T} is independent of both U and $|\psi\rangle_\beta$. The final state of the ancilla + control, $|\Phi(U, \chi)\rangle_{ABC}$, must be independent of $|\psi\rangle_\beta$. To see why [5], let us suppose that it is not, in which case there will be at least one U and two states $|\psi\rangle_\beta$ and $|\psi'\rangle_\beta$ for which $|\Phi(U, \chi, \psi)\rangle_{ABC} \neq |\Phi(U, \chi, \psi')\rangle_{ABC}$. We imagine that U is successfully teleported for the states $|\psi\rangle_\beta$ and $|\psi'\rangle_\beta$. Suppose now that

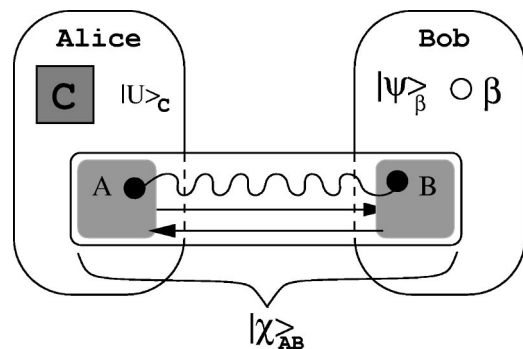

FIG. 1. Initial setup involved in the teleportation of an arbitrary unitary operation. The control system C in Alice's laboratory is initially prepared in the state $|U\rangle_C$, corresponding to the unitary operation U . This operation is to be remotely carried out on Bob's qubit β , which is initially prepared in an arbitrary pure state $|\psi\rangle_\beta$. This will be achieved by local operations in the individual laboratories, involving a collective ancilla initially prepared in the state $|\chi\rangle_{AB}$, supplemented by the exchange of classical communication, represented in the diagram by the arrow lines.

*Permanent address: Departamento de Física, Universidad de Oviedo, Calvo Sotelo s/n, 33007 Oviedo, Spain.

Bob's qubit is prepared in a superposition of these states, $(c_1|\psi\rangle + c_2|\psi'\rangle)_\beta$. The linearity of \mathcal{T} implies that the final total state will be

$$\begin{aligned} & (\mathbb{1}_{ABC} \otimes U_\beta) [c_1 |\Phi(U, \chi, \psi)\rangle_{ABC} \\ & \otimes |\psi\rangle_\beta + c_2 |\Phi(U, \chi, \psi')\rangle_{ABC} \otimes |\psi'\rangle_\beta]. \end{aligned} \quad (2)$$

The requirement that Bob's qubit undergoes a unitary evolution implies that it remains in some pure state and therefore that it cannot be entangled with the remaining systems. However, one can see that it is entangled with ABC whenever $c_1 c_2 \neq 0$. Thus, the final state of ABC must be independent of $|\psi\rangle_\beta$.

The set of all unitary operations U is infinite. This implies that, if the dimension of the control system is to be finite, then the control states $|U\rangle_C$ must, in general, be nonorthogonal. However, Nielsen and Chuang showed, in a slightly different context, that this cannot be the case [5]. The problem investigated by these authors was whether or not one could devise a universal programmable quantum gate array that could be used to store and execute any program upon a quantum register. They showed that no such finite array can be constructed. Their method of proof can readily be transferred to this context, making use of the correspondences between programmable gate array/control and register/Bob's qubit. Following their reasoning, we note that Eq. (1) and the unitarity of \mathcal{T} imply that, for any two different unitary transformations U and U' ,

$$\frac{c \langle U' | U \rangle_C}{ABC \langle \Phi(U', \chi) | \Phi(U, \chi) \rangle_{ABC}} = {}_\beta \langle \psi | U'^{\dagger} U | \psi \rangle_\beta. \quad (3)$$

The left hand side is independent of $|\psi\rangle_\beta$, and this equality is true for all $|\psi\rangle_\beta$. It follows that $U'^{\dagger} U = \gamma \mathbb{1}$, for some constant γ , leading to the conclusion that U and U' are identical up to a multiplicative constant. This conclusion, however, is valid only when the denominator on the left hand side is nonzero. If it is zero, then $c \langle U' | U \rangle_C = 0$, by the unitarity of \mathcal{T} . Control states corresponding to different unitary transformations are orthogonal, so that no finite-dimensional control system can be used to teleport an arbitrary unitary operation. For the remainder of this paper, when we speak of an arbitrary unitary operation, we will mean one that belongs to some arbitrarily large, but finite, set. We will also assume that this set contains the identity $\sigma^0 = \mathbb{1}$ and the three Pauli operators σ^i . Note that the orthogonality of the control states opens the possibility that different operations can, at least in principle, be distinguished and identified by Alice if she chooses to perform measurements on the apparatus. While this may lead to interesting tradeoffs between the resources of entanglement and classical communication, it is rather unrealistic from a practical point of view. Therefore, we exclude the possibility that Alice identifies the unknown unitary operation in this article just as we rule out that Alice obtains knowledge of the state in the course of standard quantum state teleportation.

The teleportation of U is a collective operation on spatially separated systems, which we wish to carry out using

shared entanglement and classical communication. In the derivation of lower bounds on the amount of nonlocal resources that are required to implement the teleportation of U locally, two guiding principles will be very useful [1].

(i) The amount of classical information able to be communicated by an operation in a given direction across some partition between subsystems cannot exceed the amount of information that must be sent in this direction across the same partition to complete the operation.

(ii) The amount of bipartite entanglement that an operation can establish across some partition between subsystems cannot exceed the amount of prior entanglement across the partition that must be consumed in order to complete the operation.

We now use principle (i) to establish the fact that at least two classical bits must be sent from Alice to Bob to complete the teleportation of an arbitrary U . Suppose that, rather than being prepared in a pure state, Bob's qubit is initially maximally entangled with some other qubit β' which is also in Bob's laboratory. Let us denote the four Bell states for a pair of qubits by $|B^\mu\rangle$, where $\mu = 0, \dots, 3$. Using the technique of superdense coding [6], any of the four Bell states can be transformed into any other by application of one of the Pauli operators σ^i on one of the qubits. We take this qubit to be β , and notice that the $|B^\mu\rangle$ can be ordered in such a way that $(\sigma_\beta^\mu \otimes \mathbb{1}_{\beta'}) |B^0\rangle_{\beta\beta'} = |B^\mu\rangle_{\beta\beta'}$. Alice can easily transmit two bits of information to Bob if he prepares the $\beta\beta'$ system in the state $|B^0\rangle_{\beta\beta'}$. She chooses the control system to be in one of the states $|\sigma^\mu\rangle_C$. Following the action of \mathcal{T} , Bob will be in possession of the corresponding Bell state $|B^\mu\rangle_{\beta\beta'}$. If he subsequently performs a Bell measurement on $\beta\beta'$, then he will be able to determine the value of μ , and hence the control state that Alice prepared, revealing two bits of classical information.

We now show that, by teleporting an arbitrary U according to the general prescription in Eq. (1), Alice and Bob can establish two ebits of shared entanglement. Imagine that, in addition to the systems we have already introduced, Alice has a further four-dimensional ancilla, which we shall label R . Suppose now that Alice initially prepares R and the control C in a maximally entangled state. Using the Schmidt decomposition, we can always write this state in the form $(1/2) \sum_\mu |\mu\rangle_R \otimes |\sigma^\mu\rangle_C$ where the states $|\mu\rangle_R$ are an orthonormal basis for R . Bob once more prepares the Bell state $|B^0\rangle_{\beta\beta'}$. The teleportation operation \mathcal{T} is then carried out according to Eq. (1). It is more convenient here, however, to work with a form of this equation that represents, explicitly, any local measurements made by Alice and Bob and any classical communication between them. In this case \mathcal{T} in Eq. (1) is replaced by a pair of classically correlated local CP maps, one in each laboratory. Classical information is revealed by measurements, and we let the index i denote each measurement outcome. The final state corresponding to the i th outcome is

$$|\psi_F\rangle_i = \frac{1}{2} \sum_\mu |\mu\rangle_R \otimes |\Phi_i(\sigma^\mu, \chi)\rangle_{ABC} \otimes |B^\mu\rangle_{\beta\beta'}. \quad (4)$$

We now calculate the entanglement shared by Alice and

Bob. Alice is in possession of the compound system RAC , while Bob has the system $B\beta\beta'$. For each outcome, these subsystems have respective density operators ρ_{RAC}^i and $\rho_{B\beta\beta'}^i$. Since $|\psi_F\rangle_i$ is a pure state, it follows that the entanglement shared by Alice and Bob is simply the (base 2) von Neumann entropy of either of these density operators. Fortunately, we can calculate this explicitly. To do so, we notice that the states $|\Phi_i(\sigma^\mu, \chi)\rangle_{ABC}$ will generally contain entanglement between B and AC . Let us write $\rho_B^{i\mu} = \text{Tr}_{AC}[|\Phi_i(\sigma^\mu, \chi)\rangle\langle\Phi_i(\sigma^\mu, \chi)|]$. We find that [7]

$$\rho_{B\beta\beta'} = \frac{1}{4} \sum_{\mu} (|B^\mu\rangle\langle B^\mu|)_{\beta\beta'} \otimes \rho_B^{i\mu}. \quad (5)$$

Making use of the orthogonality of the $|B^\mu\rangle$, we find that the amount of entanglement shared by Alice and Bob is simply

$$E(|\psi_F\rangle) = S(\rho_{B\beta\beta'}) = 2 + \frac{1}{4} \sum_{\mu} S(\rho_B^{i\mu}), \geq 2. \quad (6)$$

It follows from principle (ii) that at least two ebits of entanglement need to be consumed to implement \mathcal{T} locally, i.e., to teleport an arbitrary unitary operation.

We can summarize the results obtained so far as follows. The resources required to perform quantum remote control can be classified into shared entanglement and classical information transmission from Alice to Bob and from Bob to Alice. We have established absolute lower bounds on the first two of these resources. Alice and Bob have to share at least two ebits and Alice needs to transmit to Bob at least two bits of classical information.

These bounds can be attained by a procedure in which Bob teleports the state of his particle to Alice who, after applying the unitary transformation, teleports it back to him. We will call this the ‘‘bidirectional state teleportation’’ scheme. The scheme requires sending two classical bits in each direction, and using two ebits of shared entanglement. It would also be conceivable to adopt a different strategy—teleporting the state of the control system from Alice to Bob who would then implement the control directly onto β . We call this the ‘‘control state teleportation’’ scheme.

Control state teleportation is a unidirectional communication scheme from Alice to Bob, so the absolute lower bound for the communication exchange from Bob to Alice is zero. Obviously, the overall resources will depend on the dimensionality of the control system C and in general a large amount of entanglement and classical communication from Alice to Bob will be required if we want to teleport the control system. Given this situation we can trade in the resources of entanglement and classical communication by changing our scheme of choice from unidirectional communication to a bidirectional protocol. This observation may be interesting from a theoretical point of view; however, from a practical point of view one would, at least at present, favor a scheme that minimizes the entanglement consumption.

Bidirectional state teleportation saturates the lower bounds for the amount of shared ebits and classical bits transmitted from Alice to Bob and additionally uses two bits

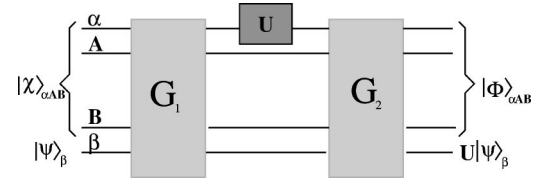

FIG. 2. Quantum circuit representation of the process of teleporting an arbitrary one-qubit transformation. The two upper wires belong to Alice and the lower ones to Bob. Initially Alice and Bob share some entanglement, represented by the joint state $|\chi\rangle_{\alpha AB}$. Operations G_1 and G_2 are modeled in terms of nonlocal unitary transformations.

of classical communication from Bob to Alice. This scheme allows the faithful implementation of U independently of the dimension of the control system. To be more efficient overall, any other scheme would need fewer resources than bidirectional state teleportation. This establishes an upper bound in the overall amount of resources required for the efficient remote implementation of an arbitrary U as four classical bits and two ebits.

We now consider an experimental scenario where the black box implementing an arbitrary transformation U is a macroscopic object, involving a (very) large number of degrees of freedom. The option of teleporting the control apparatus is then unfeasible, given that it would consume an infinite amount of entanglement and classical communication resources. However, the question remains whether there exists a more economical protocol than bidirectional state teleportation. We will prove in the following that this is not possible and bidirectional state teleportation is an unconditionally optimal way to remotely implement an arbitrary U .

Discarding the possibility of control state teleportation allows us to replace the transformation given by Eq. (1) with

$$G_2 U G_1 (|\chi\rangle_{\alpha AB} \otimes |\psi\rangle_{\beta}) = |\Phi(U, \chi)\rangle_{\alpha AB} \otimes U |\psi\rangle_{\beta}, \quad (7)$$

where certain fixed operations G_1 and G_2 are performed, respectively, prior to and following the action of the arbitrary U on a qubit α on Alice’s side. We assume that Alice and Bob share initially some entanglement, represented by the state $|\chi\rangle_{\alpha AB}$. As before, the purpose of the transformation is to perform the operation U on Bob’s qubit β . We continue to use a nonlocal unitary representation of the transformation where G_1 and G_2 are unitary operators acting on possibly all subsystems. A pictorial scheme of the situation using a quantum circuit is given in Fig. 2. The two upper wires refer to Alice’s subsystems and the two lower ones to Bob’s. Note that operations G_i are represented by nonlocal gates while the action of U takes place locally on Alice’s side.

We prove in the following that the only way that Eq. (7) can be implemented (locally) is by teleporting the state $|\psi\rangle_{\beta}$ from Bob to Alice, and then teleporting back the transformed state $U|\psi\rangle_{\beta}$ from Alice to Bob.

We begin by noting that linearity forces the transformed state of systems αAB to be independent of the particular input state $|\psi\rangle_{\beta}$. In addition, linearity imposes the condition that the state $|\Phi(U, \chi)\rangle_{\alpha AB}$ has to be independent of U itself. To see this, consider the case where the transformation U is

one of the four Pauli operators σ^μ and assume that the global state of αAB after completing the protocol may depend on the choice of U . According to Eq. (7), the combined action of the operations G_i has to be such that

$$G_2 \sigma^\mu G_1 (|\chi\rangle_{\alpha AB} \otimes |\psi\rangle_\beta) = |\Phi(\sigma^\mu, \chi)\rangle_{\alpha AB} \otimes (\sigma^\mu |\psi\rangle_\beta). \quad (8)$$

On the other hand, an arbitrary one-qubit unitary transformation U can always be decomposed in terms of the Pauli operators, $U = \sum_{\mu=0}^4 \alpha_\mu \sigma^\mu$, and it must hold that

$$G_2 U G_1 (|\chi\rangle_{\alpha AB} \otimes |\psi\rangle_\beta) = \sum_{\mu} \alpha_\mu |\Phi(\sigma^\mu, \chi)\rangle_{\alpha AB} \otimes (\sigma^\mu |\psi\rangle_\beta). \quad (9)$$

For the right-hand side (RHS) to be a product state, as is required by Eq. (7), we must have $|\Phi(\sigma^\mu, \chi)\rangle_{\alpha AB} = |\Phi(\chi)\rangle_{\alpha AB}$, independent of the operator σ^μ . This is true for any basis set of operators, and so the final state of the ancillas αAB on the RHS of Eq. (7) is independent of U .

We can now show that the operation G_1 necessarily has to be nontrivial. We do this by first assuming the contrary, that $G_1 = \mathbb{1}$, and considering two input states $|\psi\rangle_\beta$ and $|\psi'\rangle_\beta$ such that ${}_\beta \langle \psi' | \psi \rangle_\beta = 0$, and two unitary transformations U and U' which bring these two states to the same state $|\gamma\rangle_\beta$. Using Eq. (7), this implies that

$$\begin{aligned} G_2(U|\chi\rangle_{\alpha AB}|\psi\rangle_\beta) &= |\Phi(\chi)\rangle_{\alpha AB} \otimes |\gamma\rangle_\beta, \\ G_2(U'|\chi\rangle_{\alpha AB}|\psi'\rangle_\beta) &= |\Phi(\chi)\rangle_{\alpha AB} \otimes |\gamma\rangle_\beta. \end{aligned} \quad (10)$$

No universal unitary action G_2 can be found to satisfy Eq. (10), as this would require the mapping of orthogonal states onto the same state. This shows that no universal operation G_2 that satisfies Eq. (10) can exist and therefore, for the U teleportation to succeed, G_1 has to be nontrivial.

The final step in our proof is to rewrite Eq. (7) as

$$U G_1 (|\chi\rangle_{\alpha AB} \otimes |\psi\rangle_\beta) = G_2^\dagger (|\Phi(\chi)\rangle_{\alpha AB} \otimes U |\psi\rangle_\beta). \quad (11)$$

Since G_1 and G_2 are universal gates, we may choose U and $|\psi\rangle_\beta$ freely. For each $|\psi\rangle_\beta$ let the operator U_ψ be such that $U_\psi |\psi\rangle_\beta = |0\rangle$ where $\sigma_z |0\rangle = |0\rangle$. If $U = \sigma_z U_\psi$, then

$$\begin{aligned} (\sigma_z U_\psi) G_1 (|\chi\rangle_{\alpha AB} \otimes |\psi\rangle_\beta) &= G_2^\dagger (|\Phi(\chi)\rangle_{\alpha AB} \otimes \sigma_z U_\psi |\psi\rangle_\beta) \\ &= G_2^\dagger (|\Phi(\chi)\rangle_{\alpha AB} \otimes |0\rangle_\beta). \end{aligned}$$

The RHS is simply $(U_\psi) G_1 (|\chi\rangle_{\alpha AB} \otimes |\psi\rangle_\beta)$ and so, necessarily, $(U_\psi) G_1 (|\chi\rangle_{\alpha AB} \otimes |\psi\rangle_\beta)$ is the eigenstate $|0\rangle_\alpha \otimes |\phi\rangle_{AB\beta}$ of $(\sigma_z)_\alpha \otimes \mathbb{1}_{AB\beta}$. Equivalently,

$$\begin{aligned} G_1 (|\chi\rangle_{\alpha AB} \otimes |\psi\rangle_\beta) &= (U_\psi^\dagger |0\rangle_\alpha) \otimes |\phi\rangle_{AB\beta} \\ &= |\psi\rangle_\alpha \otimes |\phi\rangle_{AB\beta}. \end{aligned} \quad (12)$$

In other words, the operation G_1 necessarily transfers Bob's state $|\psi\rangle$ to Alice's qubit α . Substituting Eq. (12) into Eq. (7) then shows that G_2 necessarily transfers $U|\psi\rangle$ back to Bob's qubit β . In other words, the state of Bob's qubit must be brought to Alice for it to be acted on by the local operator U . This constitutes a no-go theorem: *a local unitary operation U cannot act remotely*. From these results and the fact that quantum state teleportation is an optimal procedure for local state transfer, we conclude that the optimal procedure for implementing locally a universal U teleportation scheme is by means of bidirectional state teleportation.

In this paper we have investigated the potential use of local operations, classical communication, and shared entanglement (LOCCSE) for the remote control of a quantum system. We have determined requirements that must be satisfied by any method that implements this task by LOCCSE means. In particular, we have shown that, if Alice can teleport an arbitrary unitary operation to a qubit in her colleague Bob's laboratory, then she must communicate at least two bits of classical information to him, and they must share at least two ebits of entanglement. If the unitary operation is remotely implemented by a classical apparatus, then to effect the teleportation at least two classical bits must also be transmitted from Bob to Alice. These resources can be used to perform the teleportation of U using bidirectional state teleportation. Remarkably, no protocol employing a smaller amount of resources is possible.

Further research should be able to shed light on possible tradeoffs between entanglement and classical communication as well as lead to ways in which LOCCSE can be used to control remotely the properties of other quantum system, with potential applications ranging from remotely synchronized time evolutions to distributed quantum computing.

The authors thank O. Steuernagel and S. M. Barnett for discussions and D. Jonathan and S. Virmani for critically reading the manuscript. This work has been supported by The Leverhulme Trust, the EQUIP project of the European Union, the Engineering and Physical Sciences Research Council (EPSRC), and DGICYT Project No. PB-98-0191 (Spain).

-
- [1] M.B. Plenio and V. Vedral, *Contemp. Phys.* **39**, 431 (1998), and references therein.
 [2] J.S. Bell, *Speakable and Unsayable in Quantum Mechanics: Collected Papers on Quantum Philosophy* (Cambridge University Press, Cambridge, 1987).
 [3] C.H. Bennett *et al.*, *Phys. Rev. Lett.* **70**, 1895 (1993).
 [4] W.K. Wootters and W.H. Zurek, *Nature (London)* **299**, 802 (1982).

- [5] M.A. Nielsen and I.L. Chuang, *Phys. Rev. Lett.* **79**, 321 (1997).
 [6] C.H. Bennett and S.J. Wiesner, *Phys. Rev. Lett.* **69**, 2881 (1992).
 [7] Although subsystems may move from one laboratory to the other for the purposes of classical communication, their locations will be revealed by the measurement, making $\rho_{B\beta\beta}^i$ well defined.