

Broadening and shifting of the methanol 119- μm gain line of linear and circular polarization by collision with chiral molecules

J. S. Bakos, G. Djotyan, Zsuzsa Sörlei, and J. Szigeti

Department of Plasma Physics, Research Institute for Particle and Nuclear Physics of the Hungarian Academy of Sciences, H-1525, Budapest, Hungary

D. K. Mansfield

Plasma Physics Laboratory, Princeton University, Princeton, New Jersey 08543

J. Sárközi

GE Lightning Tungfram Ltd., Váci ut 77, H-1340, Budapest, Hungary

(Received 22 June 2000; published 8 December 2000)

Evidence of circular dichroism has been observed in the spectral properties of a gas of left-right symmetric molecules. This dichroism comes about as the result of collisions of the symmetric molecules with left-right asymmetric molecules introduced as a buffer gas. In this sense, the dichroism can be said to have been transferred from the chiral buffer molecules to the symmetric, nonchiral molecules of the background vapor. This transferred dichroism appears as a broadening in the gain line of the symmetric molecule that is asymmetric with respect to the right or left handedness of a circularly polarized probe. The broadening of the 119- μm line of the methanol molecule was observed using infrared–far-infrared double-resonance spectroscopy.

DOI: 10.1103/PhysRevA.63.012507

PACS number(s): 33.55.Ad, 33.20.-t, 34.10.+x, 51.90.+r

I. INTRODUCTION

It is well known that the pressure broadening of a spectral line depends sensitively on the energy-level structure of the colliding-partner molecules. For example, accidental coincidences of the energy levels of the partner molecules can cause an increase of the collision cross section and, consequently, increases in the effective pressure-broadening coefficient. Baranova and Zel'dovich have investigated theoretically the question of what happens to the line broadening in a gas of left-right symmetric molecules if the colliding partner is a left-right asymmetric (i.e., chiral) molecule [1]. In their theory, the complex broadening coefficient (Γ) describing the line of a symmetric molecule contains the line broadening [$\Gamma_c(v, \Omega_r)$] and the level shift [$\Delta\omega(v, \Omega_r)$] simultaneously and is written as

$$\Gamma = \Gamma_c(v, \Omega_r) + i\Delta\omega(v, \Omega_r) = Nv_T \left(a' + ia'' + (b' + ib'') \frac{(\vec{\Omega}_r \cdot \vec{v})}{\Omega_r v_T} \right). \quad (1)$$

In this expression, v is the velocity of a class of molecules selected out of the Maxwellian velocity distribution of the molecules to be investigated. The mean thermal velocity of the gas is given by v_T . The rotational angular velocity of the molecule is represented by Ω_r while the density of the molecules in the gas is given by N . The transition associated with the line in question is assumed to involve a change of angular momentum quantum number $\Delta J = \pm 1$.

In expression (1) the $\beta_s = v_T a'$ and $\gamma_s = v_T a''$ terms give the pressure-broadening coefficient and the line-shift characteristic of collisions between left-right symmetric molecules. The asymmetry caused by the chirality of a colliding partner

is expressed by the third term containing the coefficients b' and b'' . These coefficients determine the additional (asymmetric) line broadening $\beta_a = v_T b' (\vec{\Omega}_r \cdot \vec{v}) / \Omega_r v_T$ and shift $\gamma_a = v_T b'' (\vec{\Omega}_r \cdot \vec{v}) / \Omega_r v_T$ caused by one selected velocity group (v) out of the thermal distribution. In the case of symmetric molecules, the directional distribution of the angular velocity is uniform and, therefore, the third term in expression (1) is zero. If, however, collisions with chiral molecules cause an asymmetry in the direction of the angular velocity distribution, it can be noticed as an increase or decrease in the broadening coefficient and the shift, consisting of symmetrical and asymmetrical parts. Moreover, transitions induced by circularly polarized light (represented below by σ^+ for right circular or σ^- for left circular) take place mainly from energy levels with the projection of angular momentum to the wave vector of propagation opposite to each other [1]. Any asymmetry in the directional distribution of the angular velocity vector caused by collisions with left-right asymmetric molecules should, therefore, manifest itself as a difference in the broadening and line shift for probe beams with opposite states of circular polarization.

The goal of our experimental work was to find this difference with respect to σ^+ and σ^- probe beams in the broadening and line shift of a gas of symmetric molecules caused by collisions with left-right asymmetric molecules. The search for this effect was carried out in a gain line rather than in an absorption line for which the theory was written. By choosing to work with a gain line we were able to use a modified version of an experimental setup that had been previously employed for spectroscopic measurements of the broadening of the 119- μm line in methanol caused by the addition of various (symmetric) buffer gases [2,3]. The experimental apparatus is described in detail elsewhere [4]. In

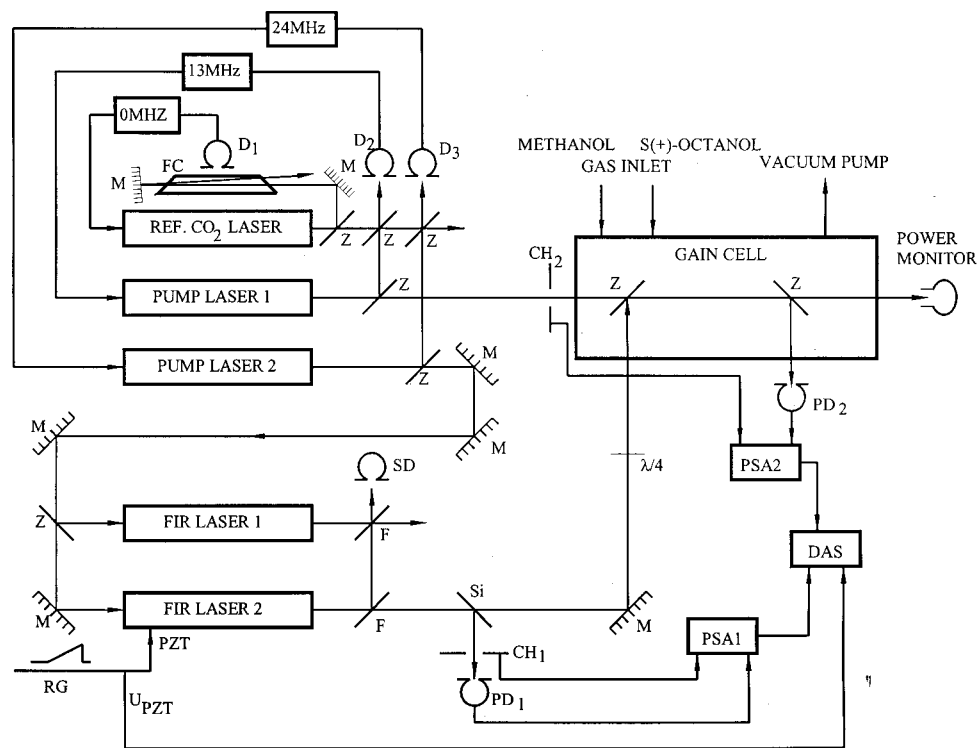

FIG. 1. The experimental setup. The ref. CO₂ laser is line-center stabilized using a CO₂ vapor fluorescence cell FC while D1 represents an InSb liquid-nitrogen-cooled detector. The pump laser 1 and pump laser 2 are off-center stabilized to pump the gain cell and the FIR lasers, respectively; D2 and D3 are HgCdTe liquid-nitrogen-cooled detectors. Frequency tuning of FIR laser 2 was accomplished by a PZT (piezo translator) driven by a ramp generator labeled RG. The beat frequency between the tunable FIR laser 2 and the center-frequency-fixed FIR laser 1 was monitored by a Schottky diode labeled SD. CH1 and CH2 are mechanical choppers, PSA1 and PSA2 are phase-sensitive amplifiers, and PD1 and PD2 are pyroelectric detectors. In all cases Z and F represent ZnSe and foil beam splitters while M represents metallic mirrors. All data were stored in the data-acquisition system DAS.

the earlier measurements, the gain broadening was measured for linear polarization only. In this work, we measured the broadening and shift of the 119- μm line using both linearly and circularly polarized probe beams (σ^+ and σ^-). We selected as a left-right asymmetric colliding partner the chiral S-octanol molecule [5].

In this report, we briefly describe our experimental apparatus in Sec. II. The results of the measurements as well as a discussion are presented in Sec. III and a summary is given in Sec. IV.

II. THE MEASUREMENT AND THE EXPERIMENTAL SETUP

Using a probe beam from an optically pumped far-infrared (OPFIR) methanol laser, the shape of the gain curve for the rotational transition $J=16 \rightarrow J'=15$ in the vibrationally excited manifold of the methanol molecule ($v=1$, $\lambda=119 \mu\text{m}$) was measured in a gain cell. A probe beam was tuned around the 119- μm resonant wavelength by translating one of the mirrors of a laser cavity [FIR laser 2 (FIR2) in Fig. 1]. Using a piezoelectric translator (PZT), the probe laser was tuned over a frequency interval of about 1 MHz. The polarization state of the far-infrared probe beam was varied from linear to σ^+ or σ^- polarization by using a

quarter-wave plate. The methanol molecules in the gain cell were pumped into the vibrationally excited state by a frequency-stabilized CO₂ laser [pump laser 1 in Fig. 1 (L1)]. The frequency of the pumping laser was purposely offset from the absorption line center of the methanol molecule. The frequency offset (11 MHz) of the pump laser from the methanol absorption line center was actively stabilized by “beating” a portion of the L1 output against the output of another CO₂ laser [ref. CO₂ laser (LSL) in Fig. 1] which was frequency stabilized to the center of the 9P36 (9.69- μm) line using a resonance fluorescence cell. The center frequency of the methanol absorption line is 24 MHz from the CO₂ 9P36 pumping line center. A frequency offset of 13 MHz with respect to the 9P36 line center was maintained by the active feedback system. This offset, in turn, ensured that an 11 MHz offset of the pump frequency from the methanol absorption line center was maintained. The beams from the CO₂ pump laser (L1) and a frequency-tunable OPFIR probe laser (FIR2) were overlapped and propagated parallel to each other along the length of the gain cell. Because of the 11 MHz frequency offset of the pump beam from the methanol absorption line center, only the molecules of a well-defined velocity group ($v=1.05 \times 10^4 \text{ cm/sec}$) were excited and took part in the creation of the FIR gain line [6].

The FIR2 probe laser was pumped by a third CO₂ laser

[pump laser 2 (L2) in Fig. 1] which was also actively stabilized at a frequency offset 24 MHz from the 9P36 line center (i.e., exactly at the methanol absorption line center). As was done for L1, frequency stabilization was accomplished by beating a portion of the L2 output against the LSL output. The L2 CO₂ laser simultaneously pumped both FIR2 and a second OPFIR [FIR laser 1 (FIR1) in Fig. 1] which was tuned to the center of the 119- μ m methanol line. This second laser acted as a FIR frequency standard. The frequency tuning of the FIR2 laser was calibrated by mixing the outputs from the two OPFIR lasers in a Schottky diode detector and measuring the resulting beat frequency.

The gain experienced by the FIR2 probe beam was measured by chopping the CO₂ pump laser beam (L1) using chopper CH2 as shown in Fig. 1. The intensity of the FIR2 beam measured at the exit of the gain cell was modulated at the CH2 chopper frequency because of the modulation of the FIR gain caused by the chopping of the pump. The amplitude of the FIR modulation was proportional to the overall gain in the cell and was detected by a pyroelectric detector (PD2 in Fig. 1) [2,3]. The modulation amplitude was also proportional to the intensity of the FIR2 probe beam at the entrance of the gain cell, which changed during the frequency scan in proportion to the laser line shape. In order to compensate for this change, therefore, the laser line shape was measured separately by another pyroelectric detector (PD1 in Fig. 1). The PD2 detector signal was subsequently divided by the PD1 signal to arrive at the dependence of the gain in the cell on the frequency of the probe beam (i.e., the shape of the gain curve).

The width of the gain curve derived in this manner allows for a determination of the pressure-broadening coefficient because the natural width of the line can be assumed to be negligible. Moreover, at a given methanol pressure, the shift of the gain from the line center in the low-pressure limit represents the shift of the line induced by methanol-methanol collisions. If an equivalent pressure of some buffer gas other than methanol is added to a methanol background gas, the broadening and shift of the line caused by molecular collisions with the buffer gas can be determined with the experimental setup described above.

III. RESULTS OF THE MEASUREMENT AND DISCUSSION

In this work, we measured the self-broadening of the methanol line with linearly (π) and σ^+ - and σ^- -polarized probe beams at a working methanol pressure of 100 mtorr. We next added 100 mtorr of *S*-octanol to the 100 mtorr of methanol in the gain cell and measured the broadening and shift of the line caused by the chiral buffer gas. This measurement was also accomplished with linearly and σ^+ - and σ^- -polarized probe beams.

The measured gain curves were then fitted by Lorentzians. The results of the fits gave the shifts of the central frequencies as well as the widths of the lines with the appropriate statistical errors.

A. Methanol self-broadening for linearly polarized (π) probe

The measured methanol self-broadening coefficient was $\beta_{\pi,m-m} = v_T a'_{\pi,m-m} = 29 \pm 0.6$ MHz/torr [see Eq. (1)]. This result is about 20% higher than that published in our earlier paper [2]. This increase was expected because there is a contribution from power broadening caused by the pump beam to the measured linewidth at such a low working pressure (100 mtorr). In this approximation the measured width is interpreted as caused only by methanol-methanol molecule collisions. The value published earlier pertained to higher working pressures where the contribution from power broadening could be neglected or properly taken into account. The value of this width is used for comparisons with the results for circular-polarized probe beams and for *S*-octanol buffer gas addition described below.

B. Methanol self-broadening for circularly polarized (σ^+ , σ^-) probe

The methanol self-broadening coefficient for circular polarization $\beta_{\sigma^+,m-m} = v_T a'_{\sigma^+,m-m}$ was found to be larger than for π polarization ($\beta_{\pi,m-m}$). The increase for σ^+ polarization was measured to be $\beta_{\sigma^+,m-m} - \beta_{\pi,m-m} = v_T (a'_{\sigma^+,m-m} - a'_{\pi,m-m}) = 4.4 \pm 1.2$ MHz/torr while the increase for σ^- polarization was $\beta_{\sigma^-,m-m} - \beta_{\pi,m-m} = v_T (a'_{\sigma^-,m-m} - a'_{\pi,m-m}) = 4.8 \pm 1.1$ MHz/torr [see Eq. (1)]. We note that the measured increase in the methanol self-broadening coefficient is nearly the same for σ^+ and σ^- polarizations. No difference with respect to σ^+ - and σ^- -polarized probe beams is expected in the case of collisions between left-right symmetric molecules, i.e., $\beta_{\sigma^+,m-m} \sim \beta_{\sigma^-,m-m} = \beta_{\sigma,m-m}$. It should be further noted that this statement is not influenced by power broadening, which drops out of the expressions for the increase in the line broadening.

C. Line shift in methanol self-broadening collisions for circularly polarized (σ^+ , σ^-) probe

The shift of the line center for a σ^+ -polarized probe $\gamma_{\sigma^+,m-m} = v_T a''_{\sigma^+,m-m}$ as compared to the line center for a linearly polarized probe $\gamma_{\pi,m-m} = v_T a''_{\pi,m-m}$ was measured as $\gamma_{\sigma^+,m-m} - \gamma_{\pi,m-m} = v_T (a''_{\sigma^+,m-m} - a''_{\pi,m-m}) = -1.7 \pm 0.1$ MHz/torr and that for a σ^- -polarized probe as $\gamma_{\sigma^-,m-m} - \gamma_{\pi,m-m} = v_T (a''_{\sigma^-,m-m} - a''_{\pi,m-m}) = -1.4 \pm 0.1$ MHz/torr [see Eq. (1)]. It may again be noted that, as expected, no significant difference was observed for the cases of σ^+ - and σ^- -polarized probes, i.e., $\gamma_{\sigma^+,m-m} \sim \gamma_{\sigma^-,m-m} = \gamma_{\sigma,m-m}$.

D. Line broadening in methanol-*S*(+)-octanol collisions for circularly polarized (σ^+ , σ^-) probe

A characteristic feature of the observed broadening is that it has symmetric as well as asymmetric contributions with respect to the σ^+ and σ^- polarization states of the probe beam.

1. σ^+ -polarized probe

Using a σ^+ -polarized probe and a 100-mtorr methanol fill of the gain cell the linewidth was determined to be

$\Gamma_{\sigma^+,m-m} = 3.34 \pm 0.06$ MHz. When 100 mtorr of *S*-(+)-octanol was added to the 100 mtorr of methanol in the gain cell, the line was seen to broaden. The linewidth in the presence of the buffer was measured as $\Gamma_{\sigma^+,m-S} = 4.37 \pm 0.03$ MHz. The increase of the width of the line as the result of the collisions of the methanol molecules with the buffer gas was therefore determined to be $\Delta\Gamma_{\sigma^+} = \Gamma_{\sigma^+,m-S} - \Gamma_{\sigma^+,m-m} = +1.03 \pm 0.09$ MHz.

2. σ^- -polarized probe

Using a σ^- -polarized probe and a 100-mtorr methanol fill of the gain cell the linewidth was determined to be $\Gamma_{\sigma^-,m-m} = 3.38 \pm 0.05$ MHz. When 100 mtorr of *S*-(+)-octanol was added to the 100 mtorr of methanol in the gain cell the line was seen to *narrow*. The linewidth in the presence of the buffer was measured as $\Gamma_{\sigma^-,m-S} = 2.94 \pm 0.07$ MHz. The increase of the width of the line as a result of the collisions of the methanol molecules with the buffer gas was therefore determined to be $\Delta\Gamma_{\sigma^-} = \Gamma_{\sigma^-,m-S} - \Gamma_{\sigma^-,m-m} = -0.4 \pm 0.1$ MHz.

The measured linewidth can be expressed by the a and b coefficients for the appropriate collision pairs using Eq. (1) as follows:

$$\Gamma_{\sigma^\pm,m-S} = N_{S,0.1} v_T \left(a'_{\sigma^\pm,m-S} + b'_{\sigma^\pm,m-S} \frac{(\vec{\Omega}_r \cdot \vec{v})}{\Omega_r v_T} \right) + N_{m,0.1} v_T a'_{\sigma^\pm,m-m}. \quad (2)$$

Here $N_{S,0.1}$ is the density of the *S*-(+)-octanol molecule corresponding to the 0.1 torr pressure used in the experiment while $a'_{\sigma^\pm,m-S}$, $b'_{\sigma^\pm,m-S}$, and $a'_{\sigma^\pm,m-m}$ are the a and b coefficients for the corresponding methanol-*S*-(+)-octanol and methanol-methanol molecular collisions for σ^\pm probe beams, respectively. The change of linewidth caused by the addition of 100 mtorr *S*-(+)-octanol buffer gas to the 100 mtorr methanol fill can be expressed by using Eq. (2):

$$\Delta\Gamma_{\sigma^\pm} = N_{S,0.1} v_T \left(a'_{\sigma^\pm,m-S} \pm b'_{\sigma^\pm,m-S} \frac{v}{v_T} \right). \quad (3)$$

The calculated thermal speed in our experiment was $v_T = 2.8 \times 10^4$ cm/sec. From Eq. (3) the symmetrical excess pressure-broadening coefficient caused by the buffer gas and defined at a pressure of 1 torr is given as

$$\beta_{\sigma,m-S}^{(s)} = \frac{N_{S,1}}{N_{S,0.1}} \left(\frac{\Delta\Gamma_{\sigma^+} + \Delta\Gamma_{\sigma^-}}{2} \right) = v_T a'_{\sigma,m-S}, \quad (4)$$

where $N_{S,1}$ is the density of the *S*-(+)-octanol molecules corresponding to a 1 torr pressure at room temperature. Similarly, the asymmetric component of the excess pressure-broadening coefficient is given as

$$\beta_{\sigma,m-S}^{(a)} = \frac{N_{S,1}}{N_{S,0.1}} \left(\frac{\Delta\Gamma_{\sigma^+} - \Delta\Gamma_{\sigma^-}}{2} \right) = v_T b'_{\sigma,m-S}. \quad (5)$$

Using the data from the experiment the asymmetric part of the pressure coefficient of broadening is given by $\beta_{\sigma,m-S}^{(a)}$

$= v_T b'_{\sigma,m-S} = 27.5 \pm 7.9$ MHz/torr [see Eq. (5)]. Because the narrowing and broadening were not observed to be equal for σ^+ - and σ^- -polarized probe beams, there was determined to be a small homogenous part—an additional homogeneous broadening coefficient, i.e., $\beta_{\sigma,m-S}^{(s)} = v_T a'_{\sigma,m-S} = +3 \pm 2$ MHz/torr.

In the calculations described above, the independence of the a and b coefficients of the σ polarization state of the probe beam was assumed:

$$\begin{aligned} a'_{\sigma^\pm,m-S} &= a'_{\sigma,m-S}, \\ b'_{\sigma^\pm,m-S} &= b'_{\sigma,m-S}. \end{aligned} \quad (6)$$

E. Line shift in methanol-*S*-octanol collisions for circularly polarized probe

Using a procedure similar to that outlined in Sec. III D, the shift of the line caused by collisions with the buffer gas molecules was calculated using the experimental data. As was the case for the broadening coefficient, the coefficient of the line shift was also determined to be predominantly asymmetric with respect to σ^+ and σ^- polarizations and also to contain a small symmetric contribution. The asymmetric part was measured to be $\gamma_{\sigma,m-S}^{(a)} = v_T b''_{m-S} = +2.2 \pm 1$ MHz/torr. The symmetric component of the pressure coefficient of the line shift was measured as $\gamma_{\sigma,m-S}^{(s)} = v_T a''_{\sigma,m-S} = +0.4 \pm 0.25$ MHz/torr.

F. Line broadening and shift in methanol-*S*-(+)-octanol collisions for linearly polarized probe

Using a linearly polarized probe we measured the pressure-broadening coefficient determined by the collisions of the methanol molecules with *S*-(+)-octanol molecules. In this case only symmetric broadening was observed. The measured value was $\beta_{\pi,m-S} = v_T a'_{\pi,m-S} = +8 \pm 2$ MHz/torr. This value is much higher than that for symmetric broadening ($\beta_{\sigma,m-S}^{(s)}$) seen with a circularly polarized probe. The pressure coefficient of the shift of the line caused by collisions of the methanol molecules with the *S*-(+)-octanol molecules was measured as $\beta_{\pi,m-S} = v_T a'_{\pi,m-S} = +2 \pm 0.2$ MHz/torr.

IV. SUMMARY

We have measured the pressure broadening and line shift of the 119- μ m gain line of optically pumped methyl alcohol molecules caused by the addition of a buffer gas of chiral *S*-octanol molecules to a methanol vapor. Referring to the theory of Baranova and Zel'dovich, resonant optical activity was expected in the left-right symmetric methanol molecules as the result of collisions with the chiral molecules. This transferred dichroism is predicted to appear as an asymmetry

in the pressure-broadening behavior with respect to σ^+ and σ^- polarization of the gain of the symmetric (i.e., nonchiral) methanol molecules. Consistent with the theory, we observed a broadening and shift of the gain line of the symmetric methanol molecules that is asymmetric with respect to the right or left handedness of a circularly polarized probe.

ACKNOWLEDGMENTS

This work was supported by the U.S.-Hungarian Science & Technology Program under Contract No. JFNo.-394 and the Research Fund (OTKA) of the Hungarian Academy of Sciences under Contract No. T-016658.

-
- [1] N. B. Baranova and B. Ya. Zel'dovich, *Opt. Lett.* **3**, 1 (1978).
[2] J. S. Bakos, K. Mandula, and Zs. Sörlei, *IEEE J. Quantum Electron.* **QE-27**, 1094 (1991).
[3] J. S. Bakos, P. N. Ignácz, A. Lörincz, Zs. Sörlei, and J. Szigeti, *Appl. Phys. B: Photophys. Laser Chem.* **57**, 89 (1993).
[4] J. Sárközi, J. S. Bakos, G. P. Djotyan, and Zs. Sörlei, *Rev. Sci. Instrum.* **67**, 3454 (1996).
[5] Fluka Chemika, *Chiral Compound Chemistry* (Fluka Chemie AG, Switzerland, 1994).
[6] D. Seligson, M. Ducloy, J. R. R. Leite, A. Sanchez, and M. S. Feld, *IEEE J. Quantum Electron.* **QE-13**, 468 (1977).