

# Quantum teleportation and Bell's inequality using single-particle entanglement

Hai-Woong Lee\* and Jaewan Kim†

*Department of Physics, Korea Advanced Institute of Science and Technology, Taejeon 305-701, Korea*

(Received 21 July 2000; published 11 December 2000)

A single-particle entangled state can be generated by illuminating a beam splitter with a single photon. Quantum teleportation utilizing such a single-particle entangled state can be successfully achieved with a simple setup consisting only of linear optical devices such as beam splitters and phase shifters. Application of the locality assumption to a single-particle entangled state leads to Bell's inequality, a violation of which signifies the nonlocal nature of a single particle.

DOI: 10.1103/PhysRevA.63.012305

PACS number(s): 03.67.-a, 03.65.Ta, 42.50.-p

## I. INTRODUCTION

It has long been realized that the striking nonclassical nature of entanglement lies at the heart of the study of fundamental issues in quantum mechanics, as witnessed by the Einstein-Podolsky-Rosen (EPR) paper [1], Bell's theorem [2], and its subsequent experimental verifications [3,4]. The recent surge of interest and progress in quantum information theory allows one to take a more positive view of entanglement and regard it as an essential resource for many ingenious applications such as quantum teleportation [5,6] and quantum cryptography [7]. These applications rely on the ability to engineer and manipulate entangled states in a controlled way. So far, the generation and manipulation of entangled states have been demonstrated with photon pairs produced in optical processes such as parametric downconversion [6,8], with ions in an ion trap [9], and with atoms in cavity-QED experiments [10]. All these experiments use as a source of entanglement two or more spatially separated particles (photons, ions, or atoms) possessing correlated properties.

In this paper we consider entanglement produced with a single particle ("single-particle entanglement") and explore its usefulness. As a prototype of a single-particle entangled state, we take an output state emerging from a lossless 50/50 beam splitter irradiated by a single photon. Here the one-photon state and the vacuum state can be regarded to represent the logical states 1 and 0 of the qubit. Single photons have already been considered as a unit to carry logical states of the qubit in a proposal to construct a quantum optical model of the Fredkin gate [11]. Recently, it has been proposed that the single-photon entangled state be used to create macroscopic entangled field states [12].

The main purpose of this paper is twofold. First, we wish to present a scheme for quantum teleportation based on the single-photon entangled state. A characteristic feature of this scheme is that it requires only linear optical devices such as beam splitters and phase shifters and thus provides a way of achieving all linear optical teleportation along the line suggested by Cerf *et al.* [13]. Second, we wish to derive a single-particle version of Bell's inequality that is applied to

an interference pattern produced by single particles. A violation of this inequality establishes the nonlocal nature of a system described by a single-particle entangled state.

## II. SINGLE-PARTICLE ENTANGLEMENT

Let us consider a single photon incident on a lossless symmetric 50/50 beam splitter equipped with a pair of  $-\pi/2$  phase shifters, as depicted in Fig. 1. Denoting the two input ports of the beam splitter by  $I$  and  $J$  and the output ports by  $A$  and  $B$ , and assuming that the photon enters the beam splitter through the input port  $I$ , the input state can be written as  $|1\rangle_I|0\rangle_J$ , where  $|1\rangle$  and  $|0\rangle$  are the one-photon state and the vacuum state, respectively, and the subscripts  $I$  and  $J$  refer to the modes of photon entering the beam splitter through the input ports  $I$  and  $J$ , respectively. The output state emerging from the beam splitter is then given by

$$|\Psi\rangle = \frac{1}{\sqrt{2}}(|1\rangle_A|0\rangle_B + |0\rangle_A|1\rangle_B), \quad (1)$$

where subscripts  $A$  and  $B$  refer to the modes of photon exiting the beam splitter through the output ports  $A$  and  $B$ , respectively. The state given by Eq. (1) represents a single-photon entangled state. We note that the output state is obtained in the symmetric combination as given by Eq. (1), because the phase shifter at the output port  $A$  acts to offset

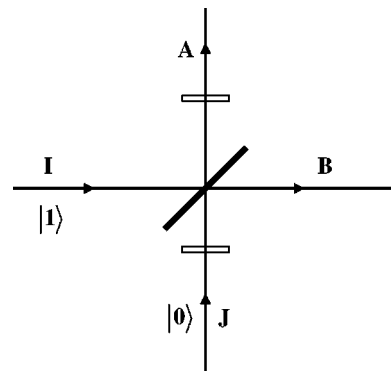

FIG. 1. Generation of a single-photon entangled state. A single photon and vacuum are incident on a beam splitter from the input ports  $I$  and  $J$ , respectively. A  $-\pi/2$  phase shifter is placed at the output port  $A$  and another at the input port  $J$ .

\*Email address: hwlee@laputa.kaist.ac.kr

†On leave from Samsung Advanced Institute of Technology.

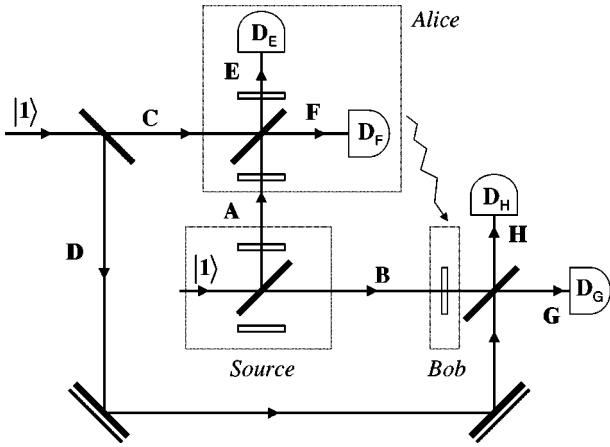

FIG. 2. Quantum teleportation experiment using single-particle entanglement. At the source station a single-photon entangled state is generated by a beam splitter. The transmitted wave  $B$  is sent to Bob, while the reflected wave  $A$  is sent to Alice who combines it with the wave  $C$  to be teleported. Alice makes a Bell measurement upon the combined waves  $A$  and  $C$  and informs the result to Bob via a classical communication channel (represented by a wavy line). When Bob is informed of Alice's measurement result, he performs a suitable unitary transformation with a  $\pi$  phase shifter. The station to the right of Bob, equipped with a beam splitter and detectors  $D_G$  and  $D_H$ , can be used to verify, if necessary, that teleportation has been successfully achieved.

the phase difference of  $\pi/2$  between the reflected and transmitted waves [14] (we assume throughout this paper that the reflected wave leads the transmitted wave by  $\pi/2$  in phase). The phase shifter at the input port  $J$  does not play any role in this case because only vacuum is present at this port.

### III. QUANTUM TELEPORTATION

We are now ready to describe a teleportation scheme that makes use of single-particle entanglement. As in the standard teleportation scheme [5,6], this scheme consists of three distinct parts as shown in Fig. 2; the source station that generates a single-photon entangled state, Alice's station where a Bell measurement is performed and its result is sent away through classical communication channels, and Bob's station where the signal from Alice is read through classical communication channels and a suitable unitary transformation is performed. Details of the teleportation procedure described below follow closely the original proposal [5].

The source station consisting of the same setup as in Fig. 1 generates a single-photon entangled state in the form of Eq. (1). The reflected wave  $A$  of the entangled state is sent to Alice and the transmitted wave  $B$  to Bob. At Alice's station this reflected wave  $A$  of the entangled state is combined via a lossless symmetric 50/50 beam splitter with a pair of  $-\pi/2$  phase shifters to a wave  $C$ , which is in an unknown superposition of a one-photon state and a vacuum state,  $a|1\rangle_C + b|0\rangle_C$ , where  $|a|^2 + |b|^2 = 1$ . This state of unknown superposition is the state that Alice wishes to teleport to Bob. The field state incident on Alice's beam splitter is  $|\Psi\rangle_{in} = (1/\sqrt{2})(|1\rangle_A|0\rangle_B + |0\rangle_A|1\rangle_B)(a|1\rangle_C + b|0\rangle_C)$ , which upon

rearrangement can be written in the Bell basis as

$$|\Psi\rangle_{in} = \frac{1}{2} [ |\Psi^{(+)}\rangle (a|1\rangle_B + b|0\rangle_B) + |\Psi^{(-)}\rangle (a|1\rangle_B - b|0\rangle_B) + |\Phi^{(+)}\rangle (a|0\rangle_B + b|1\rangle_B) + |\Phi^{(-)}\rangle (a|0\rangle_B - b|1\rangle_B) ], \quad (2)$$

where  $|\Psi^{(\pm)}\rangle$  and  $|\Phi^{(\pm)}\rangle$  are the Bell states defined by

$$|\Psi^{(\pm)}\rangle = \frac{1}{\sqrt{2}} (|0\rangle_A|1\rangle_C \pm |1\rangle_A|0\rangle_C),$$

$$|\Phi^{(\pm)}\rangle = \frac{1}{\sqrt{2}} (|1\rangle_A|1\rangle_C \pm |0\rangle_A|0\rangle_C). \quad (3)$$

A straightforward algebra based on the quantum theory of the beam splitter [14,15] yields that the output states corresponding to  $|\Psi^{(+)}\rangle$ ,  $|\Psi^{(-)}\rangle$ ,  $|\Phi^{(+)}\rangle$ , and  $|\Phi^{(-)}\rangle$  are given, respectively, by  $|0\rangle_E|1\rangle_F$ ,  $|1\rangle_E|0\rangle_F$ ,  $\frac{1}{2}(|0\rangle_E|2\rangle_F - |2\rangle_E|0\rangle_F) + 1/\sqrt{2}|0\rangle_E|0\rangle_F$ , and  $\frac{1}{2}(|0\rangle_E|2\rangle_F - |2\rangle_E|0\rangle_F) - 1/\sqrt{2}|0\rangle_E|0\rangle_F$ , where subscripts  $E$  and  $F$  refer to the modes of photon exiting the beam splitter via the output ports  $E$  and  $F$ , respectively. Thus, a detection of a single photon by the detector  $D_F$  combined with a detection of no photon by the detector  $D_E$  would indicate that the input state is  $|\Psi^{(+)}\rangle$  and that, according to Eq. (2), the state at Bob's station is  $a|1\rangle_B + b|0\rangle_B$ , exactly the state that Alice wants to teleport to Bob. In this case, Bob needs do nothing and teleportation is successfully achieved. A detection of a single photon by the detector  $D_E$  and a detection of no photon by the detector  $D_F$  would mean that the input state is  $|\Psi^{(-)}\rangle$ . The corresponding state at Bob's station is  $a|1\rangle_B - b|0\rangle_B$ . If Bob is informed of such a Bell measurement result from Alice through classical communication channels, he needs to apply a  $\pi$  phase shifter that changes the sign of the state  $|1\rangle_B$ , and teleportation is then successfully achieved. The teleportation, however, fails, either if one of the detectors registers two photons and the other none, which would mean that the input state is  $|1\rangle_A|1\rangle_C$ , or if neither detector registers any photon, which would mean that the input state is  $|0\rangle_A|0\rangle_C$ . The probability of success for our teleportation scheme is thus 50%, which is the same as the probability of success for the standard teleportation method. It has been noted [16] that a reliable (100% probability of success) teleportation cannot be achieved by linear operations due to the absence of photon-photon interactions. It should be noted that the 50% probability of success for our scheme is obtained only if the Bell states  $|\Psi^{(+)}\rangle$  and  $|\Psi^{(-)}\rangle$  are clearly distinguished not only from each other but also from the states  $|1\rangle_A|1\rangle_C$  and  $|0\rangle_A|0\rangle_C$  (or from the Bell states  $|\Phi^{(+)}\rangle$  and  $|\Phi^{(-)}\rangle$ ). This means that our detectors should be capable of distinguishing a single photon from two. This is of course not an easy requirement to meet. It seems, however, that single-photon counting in the optical regime and, in particular, in the high-energy (x-ray,  $\gamma$ -ray) regime lies within the reach of the present technology. Our analysis also assumes that the detectors are of unit quantum efficiency.

The state,  $a|1\rangle_C + b|0\rangle_C$ , to be teleported in our teleportation scheme can be generated using the methods proposed in the past [17,18]. One may also generate the state to be teleported using a beam splitter, as indicated in the leftmost part of Fig. 2. The field state emerging from the beam splitter of complex reflection and transmission coefficients  $r$  and  $t$  can be written as  $t|1\rangle_C|0\rangle_D + r|0\rangle_C|1\rangle_D$ , where the subscripts  $C$  and  $D$  refer to the modes of the transmitted and reflected waves, respectively. The transmitted wave  $C$  is then directed toward Alice's station for teleportation. Alice therefore has two entangled waves in the state  $|\Psi\rangle_{in} = 1/\sqrt{2}(|1\rangle_A|0\rangle_B + |0\rangle_A|1\rangle_B)(t|1\rangle_C|0\rangle_D + r|0\rangle_C|1\rangle_D)$  to be combined in the beam splitter. She of course has a control over only the waves  $A$  and  $C$ . The state  $|\Psi\rangle_{in}$  can be rewritten in the Bell basis as

$$\begin{aligned}
 |\Psi\rangle_{in} = & \frac{1}{2} [ |\Psi^{(+)}\rangle (t|1\rangle_B|0\rangle_D + r|0\rangle_B|1\rangle_D) \\
 & + |\Psi^{(-)}\rangle (t|1\rangle_B|0\rangle_D - r|0\rangle_B|1\rangle_D) \\
 & + |\Phi^{(+)}\rangle (t|0\rangle_B|0\rangle_D + r|1\rangle_B|1\rangle_D) \\
 & + |\Phi^{(-)}\rangle (t|0\rangle_B|0\rangle_D - r|1\rangle_B|1\rangle_D) ]. \quad (4)
 \end{aligned}$$

If Alice's Bell measurement yields the state  $|\Psi^{(+)}\rangle$ , Bob has a wave  $B$  in the entangled state  $t|1\rangle_B|0\rangle_D + r|0\rangle_B|1\rangle_D$ . The teleportation is thus successfully achieved. If Alice's Bell measurement yields the state  $|\Psi^{(-)}\rangle$ , Bob needs to apply a  $\pi$  phase shifter, which changes the relative phase of the state  $|1\rangle_B|0\rangle_D$  with respect to the state  $|0\rangle_B|1\rangle_D$  by  $\pi$ . We therefore see that our scheme offers a simple way of teleporting an entangled state. That teleportation works also for entangled states was already pointed out by Bennett *et al.* [5], in their original proposal for quantum teleportation.

It is easy to confirm that teleportation has indeed been successfully achieved. As shown in the rightmost part of Fig. 2, we combine the wave  $D$  with the teleported wave  $B$  using a beam splitter that has the same transmission and reflection coefficients as the beam splitter that created the teleported entangled state  $t|1\rangle_C|0\rangle_D + r|0\rangle_C|1\rangle_D$ . If the teleportation is successful, then the input state to the beam splitter must be  $t|1\rangle_B|0\rangle_D + r|0\rangle_B|1\rangle_D$ . The situation then is exactly the reverse of the situation that created the teleported entangled state. Thus, a successful teleportation can be verified by confirming that the detector  $D_G$  detects a single photon and the detector  $D_H$  detects none.

Finally we mention that the teleportation scheme described here uses essentially the same setup as the scheme proposed by Pegg *et al.* [17], to perform optical state truncation. The similarity of the teleportation process and the truncation process has already been noted by Pegg *et al.*, and by Villas-Bôas *et al.* [19]. Whereas the input state to be truncated is a superposition of many number states including one-photon state and vacuum, and a successful truncation at one-photon state requires waiting until the two detectors register a total of one photon, the input state to be teleported is a superposition of one-photon state and vacuum, and teleportation is successful half of the times when the two detectors ( $D_E$  and  $D_F$  of Fig. 2) register a total of one photon.

#### IV. BELL'S INEQUALITY

It was shown in the previous section that single-particle entanglement can be as useful as two-particle entanglement, as far as application to quantum teleportation is concerned. Considering that two-particle entanglement provides an opportunity to test fundamental principles of quantum mechanics related to EPR paradox and Bell's theorem, one may wonder whether single-particle entanglement can offer a similar opportunity. Although up to now Bell's inequality tests have been performed with entangled photon pairs [3,4], a proposal for an experiment that demonstrates nonlocality and a violation of Bell's inequality with a single photon was made 10 years ago [20]. The proposal stimulated much interest and, at the same time, intensive debate [21]. There is no question that the proposed experiment demonstrates nonlocality of the system and a violation of Bell's inequality. It, however, does not seem entirely clear at least to some of the researchers that the outcome of the experiment can be attributed solely to an effect associated with a single photon, because the experiment requires performing a particle-particle correlation measurement.

Here, for our discussion of nonlocality with a single-particle entangled state, we concentrate on the type of correlation measurement that can certainly be attributed to a single-photon effect, i.e., a correlation measurement of the first-order type in Glauber's sense [22]. In fact, the nonlocal behavior demonstrated in the first-order interference measurement of Grangier *et al.* [23], with a Mach-Zehnder interferometer is undoubtedly a single-photon effect. We elaborate further on this experiment and show that Bell's inequality, which is violated by the experimental observation of Grangier *et al.*, can be derived based on the locality assumption. Our argument below can be considered as a derivation of a single-particle version of Bell's inequality [2,24]. We recall that it was proven [25] that any pure entangled state of two or more particles violate Bell's inequality. Our derivation allows one to extend the proof to an entangled state of a single particle. It should be noted, however, that the interference pattern observed by Grangier *et al.*, can be explained by a nonlocal classical wave theory as well as by the quantum theory. A violation of the single-particle version of Bell's inequality therefore does not establish the quantum theory as the only correct theory. Its significance lies in the fact that it gives a quantitative confirmation that a system described by a single-particle entangled state behaves nonlocally.

Consider a Mach-Zehnder interferometer consisting of a pair of lossless symmetric 50/50 beam splitters, each with a pair of  $-\pi/2$  phase shifters, and a pair of perfect mirrors, as shown in Fig. 3. A single photon and vacuum are incident on the first beam splitter from the input ports  $I$  and  $J$ , respectively. The output state is again given by  $(1/\sqrt{2})(|1\rangle_A|0\rangle_B + |0\rangle_A|1\rangle_B)$ . The reflected wave  $A$  and the transmitted wave  $B$  are recombined at the second beam splitter. Alice and Bob, located somewhere along the pathway of the reflected wave  $A$  and the transmitted wave  $B$ , respectively, are each equipped with a phase shifter. If neither Alice nor Bob applies a phase shifter, the field state emerging from the second

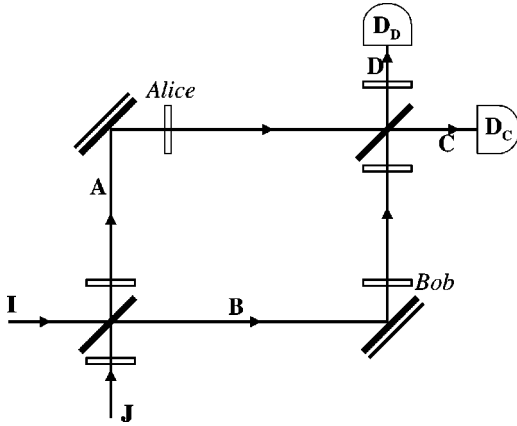

FIG. 3. Single-particle version of Bell's inequality test with a Mach-Zehnder interferometer. A single photon and vacuum are incident on the beam splitter (with a pair of  $-\pi/2$  phase shifter) from the input ports  $I$  and  $J$ , respectively. The reflected wave  $A$  and the transmitted wave  $B$  are recombined at the second beam splitter (with a pair of  $-\pi/2$  phase shifter). Alice and Bob, located somewhere along the pathway of the reflected wave  $A$  and the transmitted wave  $B$ , respectively, each have a phase shifter, which they may or may not use.

beam splitter is  $|1\rangle_C|0\rangle_D$  and it is certain that the photon strikes the detector  $D_C$ . Thus, when  $N$  photons are sent from the input port  $I$  in succession, all  $N$  photons arrive at the detector  $D_C$  and none at the detector  $D_D$ . Suppose now Alice inserts her phase shifter into the beam  $A$  and changes its phase by  $\phi_A$ . A straightforward calculation based on the quantum theory of the beam splitter [14,15] yields that the output state emerging from the second beam splitter is (apart from an overall phase factor)  $\cos(\phi_A/2)|1\rangle_C|0\rangle_D + i \sin(\phi_A/2)|0\rangle_C|1\rangle_D$ . Thus  $N_A \equiv [\sin^2(\phi_A/2)]N$  photons out of the total  $N$  incident photons change their paths and strike the detector  $D_D$  as a consequence of Alice's action to change the phase of the beam  $A$  by  $\phi_A$ . If Bob, not Alice, inserts his phase shifter into the beam  $B$  and changes its phase by  $-\phi_B$ , the output state becomes  $\cos(\phi_B/2)|1\rangle_C|0\rangle_D + i \sin(\phi_B/2)|0\rangle_C|1\rangle_D$ . Thus  $N_B \equiv [\sin^2(\phi_B/2)]N$  photons out of the total  $N$  incident photons change their paths and strike the detector  $D_D$  as a consequence of Bob's action. What would happen if both Alice and Bob use their phase shifters and change the phases of the beams  $A$  and  $B$  by  $\phi_A$  and  $-\phi_B$ , respectively? A straightforward quantum calculation yields that the output state in this case is  $\cos(\phi_A + \phi_B)/2|1\rangle_C|0\rangle_D + i \sin(\phi_A + \phi_B)/2|0\rangle_C|1\rangle_D$ , i.e.,  $N_{AB} \equiv [\sin^2(\phi_A + \phi_B)/2]N$  photons out of the  $N$  incident photons change their paths and strike the detector  $D_D$ .

On the other hand, an argument based on the locality assumption leads to a result contradictory to the above quan-

tum result. In order to show this, we assume that those photons that do not change their paths and still arrive at  $D_C$ , both when Alice, not Bob, uses her phase shifter, and when Bob, not Alice, uses his phase shifter, will still not change their paths and still arrive at  $D_C$  when both Alice and Bob use their phase shifters. This assumption means that we do not allow for any cooperative effect between Alice's phase shifter and Bob's and therefore assures independence from each other [26]. It may therefore be considered as a single-particle version of the locality assumption. Let the groups  $G_N$ ,  $G_A$ ,  $G_B$ , and  $G_{AB}$  contain, respectively, the total  $N$  photons,  $N_A$  photons that strike the detector  $D_D$  when Alice, not Bob, uses her phase shifter,  $N_B$  photons that strike the detector  $D_D$  when Bob, not Alice, uses his phase shifter, and  $N_{AB}$  photons that strike the detector  $D_D$  when both Alice and Bob use their phase shifters. The locality assumption dictates that the group  $(G_N - G_A) \cap (G_N - G_B)$  is a subset of the group  $(G_N - G_{AB})$ . Since the number of photons that belong to the group  $(G_N - G_A) \cap (G_N - G_B)$  is greater than or equal to  $N - N_A - N_B$ , it immediately follows that  $N - N_{AB} \geq N - N_A - N_B$ . We therefore arrive at the inequality  $N_{AB} \leq N_A + N_B$ . This inequality is in disagreement with the quantum theory, because the inequality,  $\sin^2(\phi_A + \phi_B)/2 \leq \sin^2(\phi_A/2) + \sin^2(\phi_B/2)$ , is clearly violated for some values of  $\phi_A$  and  $\phi_B$ . The inequality,  $\sin^2(\phi_A + \phi_B)/2 \leq \sin^2(\phi_A/2) + \sin^2(\phi_B/2)$ , is completely equivalent to the formula,  $1 + P(\vec{b}, \vec{c}) \geq |P(\vec{a}, \vec{b}) - P(\vec{a}, \vec{c})|$ , derived originally by Bell [2] for a correlated spin pair, if we take the spin correlation function  $P(\vec{a}, \vec{c}) = -\cos \phi_A$ ,  $P(\vec{b}, \vec{c}) = -\cos \phi_B$ , and  $P(\vec{a}, \vec{b}) = -\cos(\phi_A + \phi_B)$ .

## V. CONCLUSION

In conclusion, we have investigated a possibility of utilizing single-particle entanglement and shown that single-particle entanglement can be used as a useful resource for fundamental studies in quantum mechanics and for applications in quantum teleportation. An experimental scheme that utilizes single-particle entanglement generally requires production, maintenance, and detection of photons at a single-photon level. With the development of photon counting techniques and of reliable single-photon sources [27], however, the experimental realization of the schemes seems within the reach of the present technology.

## ACKNOWLEDGMENTS

This research was supported by the Brain Korea 21 Project of the Korean Ministry of Education and by the Korea Atomic Energy Research Institute (KAERI). The authors wish to thank Professors K. An, P. Ko, E. K. Lee, S. C. Lee, Y. H. Lee, E. Stewart, and Mr. J. C. Hong for helpful discussions.

- [1] A. Einstein, B. Podolsky, and N. Rosen, *Phys. Rev.* **47**, 777 (1935).
- [2] J. S. Bell, *Physics* (Long Island City, N.Y.) **1**, 195 (1964).
- [3] S. J. Freeman and J. F. Clauser, *Phys. Rev. Lett.* **28**, 938 (1972); J. F. Clauser and A. Shimony, *Rep. Prog. Phys.* **41**, 1881 (1978).
- [4] A. Aspect, P. Grangier, and G. Roger, *Phys. Rev. Lett.* **47**, 460 (1981); **49**, 91 (1982); A. Aspect, J. Dalibard, and G. Roger, *ibid.* **49**, 1804 (1982).
- [5] C. H. Bennett, G. Brassard, C. Crepeau, R. Jozsa, A. Peres, and W. K. Wootters, *Phys. Rev. Lett.* **70**, 1895 (1993).
- [6] D. Bouwmeester, J. W. Pan, K. Mattle, M. Eibl, H. Weinfurter, and A. Zeilinger, *Nature* (London) **390**, 575 (1997); D. Boschi, S. Branca, F. De Martini, L. Hardy, and S. Popescu, *Phys. Rev. Lett.* **80**, 1121 (1998); A. Furusawa, J. L. Sorensen, S. L. Braunstein, C. A. Fuchs, H. J. Kimble, and E. S. Polzik, *Science* **282**, 706 (1998).
- [7] A. K. Ekert, *Phys. Rev. Lett.* **67**, 661 (1991).
- [8] P. G. Kwiat, K. Mattle, H. Weinfurter, A. Zeilinger, A. V. Sergienko, and Y. Shih, *Phys. Rev. Lett.* **75**, 4337 (1995).
- [9] C. Monroe, D. M. Meekhof, B. E. King, and D. J. Wineland, *Science* **272**, 1131 (1996).
- [10] E. Hagley, X. Maitre, G. Nogues, C. Wunderlich, M. Brune, J. M. Raimond, and S. Haroche, *Phys. Rev. Lett.* **79**, 1 (1997).
- [11] G. J. Milburn, *Phys. Rev. Lett.* **62**, 2124 (1989).
- [12] J. C. Howell and J. A. Yeazell, *Phys. Rev. A* **62**, 012102 (2000).
- [13] N. J. Cerf, C. Adami, and P. G. Kwiat, *Phys. Rev. A* **57**, R1477 (1998).
- [14] H. Fearn and R. Loudon, *Opt. Commun.* **64**, 485 (1987); A. Zeilinger, *Am. J. Phys.* **49**, 882 (1981).
- [15] B. Yurke, S. L. McCall, and J. R. Klauder, *Phys. Rev. A* **33**, 4033 (1986); S. Prasad, M. O. Scully, and W. Martienssen, *Opt. Commun.* **62**, 139 (1987); Z. Y. Ou, C. K. Hong, and L. Mandel, *ibid.* **63**, 118 (1987); R. A. Campos, B. E. A. Saleh, and M. C. Teich, *Phys. Rev. A* **40**, 1371 (1989).
- [16] L. Vaidman and N. Yoran, *Phys. Rev. A* **59**, 116 (1999); N. Lütkenhaus, J. Calsamiglia, and K. A. Suominen, *ibid.* **59**, 3295 (1999).
- [17] D. T. Pegg, L. S. Phillips, and S. M. Barnett, *Phys. Rev. Lett.* **81**, 1604 (1998).
- [18] M. Dakna, J. Clausen, L. Knöll, and D. G. Welsch, *Phys. Rev. A* **59**, 1658 (1999); G. M. D'Ariano, L. Maccone, M. G. A. Paris, and M. F. Sacchi, *ibid.* **61**, 053817 (2000); M. G. A. Paris, *ibid.* **62**, 033813 (2000).
- [19] C. J. Villas-Bôas, N. G. de Almeida, and M. H. Y. Moussa, *Phys. Rev. A* **60**, 2759 (1999). A teleportation scheme similar to ours described here is proposed in this paper.
- [20] S. M. Tan, D. F. Walls, and M. J. Collett, *Phys. Rev. Lett.* **66**, 252 (1991); S. M. Tan, M. J. Holland, and D. F. Walls, *Opt. Commun.* **77**, 285 (1990).
- [21] E. Santos, *Phys. Rev. Lett.* **68**, 894 (1992); S. M. Tan, D. F. Walls, and M. J. Collett, *ibid.* **68**, 895 (1992); L. Hardy, *ibid.* **73**, 2279 (1994); L. Vaidman, *ibid.* **75**, 2063 (1995); D. M. Greenberger, M. A. Horne, and A. Zeilinger, *ibid.* **75**, 2064 (1995); L. Hardy, *ibid.* **75**, 2065 (1995); A. Peres, *ibid.* **74**, 4571 (1995); D. Home and G. S. Agarwal, *Phys. Lett. A* **209**, 1 (1995); C. C. Gerry, *Phys. Rev. A* **53**, 4583 (1996); R. J. C. Spreeuw, *Found. Phys.* **28**, 361 (1998).
- [22] R. J. Glauber, *Phys. Rev.* **130**, 2529 (1963); **131**, 2766 (1963).
- [23] P. Grangier, G. Roger, and A. Aspect, *Europhys. Lett.* **1**, 173 (1986).
- [24] L. E. Ballentine, *Quantum Mechanics* (World Scientific, Singapore, 1998), Chap. 20.
- [25] N. Gisin, *Phys. Lett. A* **154**, 201 (1991); N. Gisin and A. Peres, *ibid.* **162**, 15 (1992); S. Popescu and D. Rohrlich, *ibid.* **166**, 293 (1992).
- [26] This assumption, however, does not exclude the possibility that those photons that change their paths and strike the detector  $D_D$ , both when Alice, not Bob, uses her phase shifter and when Bob, not Alice, uses his phase shifter, strike the detector  $D_C$  when both Alice and Bob use their phase shifters.
- [27] C. K. Hong and L. Mandel, *Phys. Rev. Lett.* **56**, 58 (1986); J. Kim, O. Benson, H. Kan, and Y. Yamamoto, *Nature* (London) **397**, 500 (1999); C. Brunel, B. Lounis, P. Tamarat, and M. Orrit, *Phys. Rev. Lett.* **83**, 2722 (1999).