

since its size is an intrinsic property and should not depend on the method of calculations. Consequently, agreement between the values obtained from the two methods can be regarded as a consistency check. In fact, in the case of argon this was confirmed by using $h=2L$ and $h=3L$ (not

shown here).

Finally, it would be useful to apply Eqs. (4), (5), and (8) to other systems (magnetic, mixtures, etc.) exhibiting a critical phenomenon, if and when their x-ray or neutron scattering data are available.

*Work performed under the auspices of the U. S. Atomic Energy Commission.

†Career Development Awardee (1 K04 GM70115-01) from the National Institute of Health.

¹J. S. Kouvel and D. S. Rodbell, *Phys. Rev. Letters* **18**, 215 (1967).

²M. S. Green, M. Vicentini-Missoni, and J. M. H. Levelt Sengers, *Phys. Rev. Letters* **18**, 1113 (1967).

³B. Widom, *J. Chem. Phys.* **43**, 3892 (1965); **43**, 3898 (1965).

⁴L. P. Kadanoff, *Physics (N. Y.)* **2**, 263 (1966).

⁵M. E. Fisher, *J. Appl. Phys.* **38**, 981 (1967).

⁶P. G. Mikolaj and C. J. Pings, *J. Chem. Phys.* **46**, 1412 (1967); **46**, 1401 (1967).

⁷The other shapes of a cell, aside from giving somewhat lengthier results for the ensuing expressions, do not alter the following remarks in any substantial way.

⁸I. Z. Fisher and V. I. Adamovich, *J. Struct. Chem. (USSR)* **4**, 759 (1960).

⁹Recalculations of Fisher and Adamovich's work using more recent x-ray data of H₂O indicate that their conclu-

sions are substantially wrong (e.g., no peak in the correlation coefficient) and the error originates from the use of inaccurate $g(r)$, which is inconsistent with the more recent works. See T. R. Chay and H. Frank, *J. Chem. Phys.* (to be published). The hard sphere $\langle(\Delta N_A)^2\rangle/\langle N_A\rangle$ and K evaluated in this work was found to behave rather similarly to the corresponding results for water, i.e., the former approaching rather slowly to the thermodynamic limit, and the latter exhibiting no peak.

¹⁰H. Cramér, *The Elements of Probability Theory* (Wiley, New York, 1955), p. 130.

¹¹P. G. Mikolaj and C. J. Pings, Document No. 9284, ADI Auxiliary Publications Project, Photo Duplication Service, Library of Congress, Washington, D. C. (unpublished).

¹²Curves a-g in Figs. 1 and 2 are calculated from the experimental data Nos. 34, 37, 35, 31, 32, 30, and 40, respectively, in Refs. 6 and 11.

¹³However, based on our unpublished results near the triple point of argon, the peak in K is expected either to disappear or to become negligible if T or ρ is very far away from the critical point.

Observations on Single Vortex Lines in Rotating Superfluid Helium*

Richard E. Packard[†] and T. M. Sanders, Jr.

H. M. Randall Laboratory of Physics, University of Michigan, Ann Arbor, Michigan

(Received 10 March 1972)

We have detected the appearance of individual quantized vortex lines in liquid He II in narrow-diameter (~1 mm) rotating cylindrical vessels which were slowly accelerated from rest. The angular velocities where the lines appear are qualitatively consistent with theory based upon minimization of the free energy. However, we find that the detailed behavior of the He II is quite history dependent and cannot be uniquely determined from existing theory. Our detection technique involves charging the vortex lines for a fixed length of time. A subsequent measurement of the amount of charge trapped provides an indication of the number of vortex lines present. In order to detect the small amount of charge trapped on a single line, we have extracted the trapped electrons through the meniscus and have developed a proportional counter to detect them in the vapor.

I. INTRODUCTION

A. General

The problem of the nature of a rotating superfluid has played an important role in the study of liquid helium since 1941. At that time Landau suggested in his classic paper¹ that the velocity field of a superfluid must always be irrotational ($\text{curl } \vec{v}_s = 0$). This would imply the remarkable result that the superfluid would not participate in rotation. In particular, if a sample of superfluid was contained in a cylindrical vessel rotating about its

symmetry axis, the liquid would simply remain at rest. Although early experiments² indicated that the superfluid did not participate in oscillatory circular motion (thus supporting Landau's idea), study of the shape of the meniscus seemed to show that the superfluid rotated like a classical liquid.³ Still further investigations showed that the rotating He II possessed at least some of the essential superfluid properties, such as the fountain effect.⁴ These apparently conflicting results were reconciled after Onsager⁵ and Feynman⁶ conceived the idea of quantized vortex lines. The idea is to re-

quire that the condition $\text{curl } \vec{v}_s = 0$ be satisfied everywhere except at singular vortex lines, around which the superfluid circulation $\kappa \equiv \oint \vec{v}_s \cdot d\vec{l}$ is quantized in units of Planck's constant divided by the mass of the helium atom ($\kappa = nh/m$). In this theory, for helium in a rotating vessel, there is a well-defined equilibrium number (and distribution) of vortices characteristic of the speed and size of the vessel. The number is zero below a critical angular velocity, at which the first vortex should appear, and the number becomes proportional to the angular velocity for sufficiently rapid rotation. The fluid comes into rotation discontinuously—in a series of quantum jumps. When many vortices are present, the macroscopic appearance of the superfluid is almost indistinguishable from a classical fluid. Thus the puzzling experiments are explained.

Quantized vortex lines have been detected by their effect on second-sound propagation, heat transfer, oscillating discs, and charged particles—but always in situations where the number of vortices is large.⁷ The regime in which only a few vortices are present has hardly been explored. A notable exception is the work of Hess and Fairbank⁸ who measured the angular momentum of a rotating capillary filled with He II. They clearly demonstrated the nonclassical behavior—in particular the nonrotation of the fluid at low angular velocities—but did not resolve the expected quantum jumps. We will show that it is possible to use charged particles to detect the presence of a single vortex line in rotating liquid helium.⁹ With this capability it becomes possible to investigate both equilibrium phenomena and nonequilibrium effects (such as the appearance and disappearance of vortices and the metastability of nonequilibrium distributions).

B. Plan of Experiment

We proposed to utilize electron trapping on vortices to detect a single vortex line. Previous work has shown that an electron in liquid helium forms a microscopic bubble (radius $\approx 16 \text{ \AA}$) which can become trapped on vortex lines.¹⁰ Although the electron bubble remains trapped for only a few seconds at 1.7 K, the lifetime increases to thousands of seconds¹¹ below 1.5 K.

The plan of the method is quite simple: Electrons are injected for a fixed length of time into a rotating cylindrical container of He II. During this period, any vortex lines present will trap electrons and become charged. After the charging process an electric field, applied along the bucket's axis, transfers any trapped charge to a collector attached to a sensitive electrometer. The electrometer registers the amount of collected charge, which is proportional to the number of

vortex lines present. The appearance of a new line will result in a steplike change in the electrometer output.

This scheme presents several experimental difficulties, which had to be overcome. The main problem is sensitivity: Previous experiments (where there were typically several thousand lines present) indicated that only a few thousand electrons can be trapped per centimeter of vortex line. This amount of charge is difficult to detect in liquid helium, because the electron-bubble mobility is quite low.¹² We planned to detect this small charge by extracting the electrons through the liquid-helium meniscus into the vapor above. Once the electrons are in the gas, amplification can be achieved in a proportional counter and larger signals will result.

To implement this plan we had to see if electrons on vortex lines could in fact be brought through the meniscus. Since a proportional counter had not been employed previously in this cryogenic helium environment, we had to develop the necessary techniques.

An independent problem lay in constructing a rotating bucket in which currents could be manipulated, and whose diameter was small enough so that only a few vortex lines would be present at speeds of the order of 1 rad/sec.

In Sec. II we briefly discuss the theory relevant to this experiment. Section III is devoted to a description of the apparatus; in the remainder of the paper we describe and discuss our observations.

II. THEORY

In this section we will present some theory needed for interpretation of experiments like the present one. Since most of the results of this section have been given elsewhere by other authors,^{13,14} we will give only the theory required for a reasonably self-contained account. There are theoretical problems to be considered on two different levels: First, what is the state of thermodynamic equilibrium for liquid helium within a rotating vessel of simple geometry? Second, in a real experimental situation will this equilibrium state be achieved? If so, by what processes? If not, what nonequilibrium phenomena may be expected? We will discuss some aspects of the equilibrium theory and give some qualitative remarks about nonequilibrium phenomena.

We consider superfluid helium contained in a right circular cylinder, rotating at angular velocity ω about its symmetry axis. The equilibrium state of this system¹⁵ minimizes the quantity $E' = E - \omega L$. Here E and L are the kinetic energy and angular momentum of the fluid. The quantity E' (often referred to as the free energy) is the energy

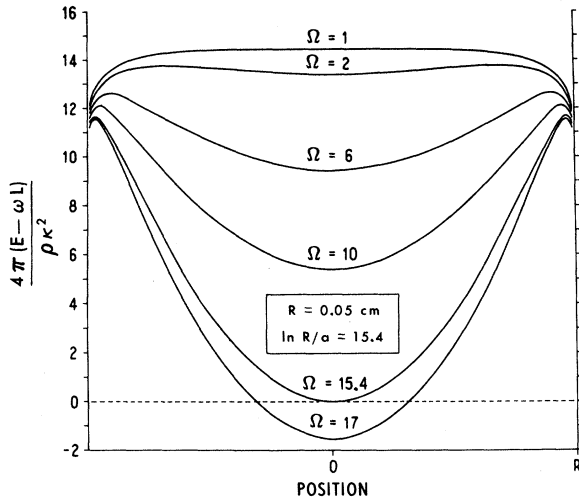

FIG. 1. Curves of free energy vs position for a single vortex line. A core parameter $a = 1.0 \text{ \AA}$ was chosen for the calculation.

in a coordinate system rotating at angular velocity ω . In equilibrium the normal-fluid component has the velocity field $\vec{v} = \vec{\omega} \times \vec{r}$ (like a classical fluid or rigid body).

The flow of the superfluid is assumed to be two dimensional and irrotational except for the occurrence of quantized vortices. Such flow will most closely resemble solid-body rotation when the number of vortices is largest and their circulation smallest. Hence the most favorable state will contain only singly quantized vortices.

When no vortices are present both E and L are zero; hence $E' = 0$ for all angular velocities. When a single vortex is present at distance r from the axis, then

$$E' = \frac{\rho\kappa^2}{4\pi} \left[\ln \frac{R}{a} + \ln \left(1 - \frac{r^2}{R^2} \right) - \Omega \left(1 - \frac{r^2}{R^2} \right) \right].$$

Here a is the vortex-core parameter, and $\Omega \equiv 2\pi R^2 \omega / \kappa$ is a dimensionless angular velocity. A plot of this relationship¹⁶ is shown in Fig. 1. For low angular velocities $0 < \Omega < 1$, the energy E' has a maximum at $r = 0$ and decreases monotonically as r increases. For $1 < \Omega < \ln(R/a)$, E' has a minimum at $r = 0$ at which $E' > 0$. As the vortex moves outward, E' increases to a maximum and then decreases as r approaches R . In this range of angular velocities the value of E' is greater than that of the vortex-free state for all positions of the vortex. For $\Omega > \ln(R/a)$, the value of E' at the central minimum is lower than that of the vortex-free state. Thus the one-vortex state is preferred over the vortex-free state for $\omega > \omega_{c1} = (\kappa/2\pi R^2) \ln(R/a)$.

This simple case can be used to illustrate the metastability of nonequilibrium states. For example, when Ω is in the range $1 < \Omega < \ln(R/a)$, the

equilibrium state of the fluid is vortex free. If, however, a single vortex were present along the axis it would be in stable equilibrium with respect to small displacements. Following such a displacement, it will be driven back toward the position which minimizes E' , by virtue of its motion with respect to the normal component.¹⁷ It will move to the wall (and presumably disappear) only if it is displaced over the maximum in $E'(r)$. Similarly, if $\Omega > \ln(R/a)$ and no vortex is present, a vortex produced at the wall will not enter the fluid unless it is somehow displaced past the maximum in $E'(r)$.

Having noted the possibility of metastable non-equilibrium states we return to a discussion of the equilibrium situation. As ω is raised from zero the equilibrium state contains no vortices for $\omega < \omega_{c1}$; one vortex is stable for a range of angular velocities above ω_{c1} and below some ω_{c2} , where the two-vortex state becomes preferred. As the angular velocity is raised further, E' is minimized by the appearance of additional vortices at well-defined angular velocities, the first few of which are calculated by Hess.¹³ When many vortices are present, a new line appears whenever ω changes by \hbar/mR^2 ; the vortex density approaches $2m\omega/h$, the value which mimics rigid rotation at angular velocity ω . The liquid, however, comes into "rotation" in a discontinuous fashion.

III. EXPERIMENTAL APPARATUS DESIGN AND PERFORMANCE

A. Rotating Cryostat

We required a device which would permit the smooth rotation of various low-temperature apparatuses. We decided to rotate, as a unit, a standard double-Dewar cryostat which was suspended from a brass pumping head mounted on an air bearing¹⁸ (Fig. 2). The cryostat was connected by a timing belt to a variable-speed transmission,¹⁹ driven by an electric motor: The angular velocity could be set manually or swept continuously. Mercury slip rings were used to connect stationary equipment to circuits attached to the rotating system. In order to cool the helium below 4.2 K, the bath was pumped through a rotating vacuum joint which utilized a commercial oil seal. The seal was the major source of friction in the rotating system.

The angular velocity of the cryostat was measured in the following way: 36 aluminum blades were positioned around the periphery of the table. These blades chopped a light beam which was incident on a photodiode, producing pulses which were fed to a frequency counter. The speed of rotation was uniform within 2% throughout a complete revolution, for $\omega > 0.1$ rad/sec. Lower speeds

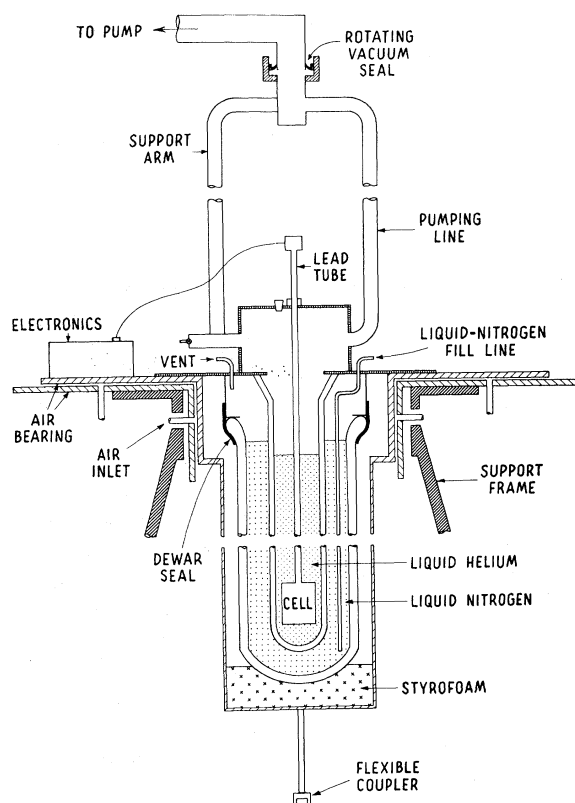

FIG. 2. Cross-section view of the rotating cryostat.

were less uniform because of elasticity in the drive system. This springiness was used to reduce vibration coupled from the motor and transmission.

B. Apparatus to Study Charge Extraction Through the Meniscus

Before we attempted to detect single vortex lines, we performed several preliminary experiments. We first investigated whether trapped electrons could be extracted through the He II meniscus. At temperatures below 1.3 K, the non-rotating liquid helium, negative carriers do not come through the liquid-vapor interface efficiently.²⁰ Our early experiments, however, showed that electrons trapped on vortex lines could pass through the meniscus with little difficulty. This phenomenon was observed in an apparatus which was rotated at speeds where several thousand vortex lines per square centimeter should be present.

The basic apparatus is the electrode structure shown in Fig. 3. A patch of Po^{210} serves as a source (S) of electrons, which are injected through the source grid (SG) and into the interaction region by the temporary application of voltages V_s and V_1 . During this charging period electrodes E1 and RM are connected to the source grid, producing a field configuration which tends to keep the carriers lo-

calized in the center of the vessel. After the vortex lines are charged in this manner for several minutes, the voltage V_s is switched to zero for a few seconds, thus turning off the source. During this time any untrapped charges are collected at the walls. Finally we apply "dump" potentials, which pull the trapped charge to the collector.

We found essentially the same amount of collected charge if the collector was immersed in the liquid or if the meniscus was set at the electrode RM—indicating that the trapped charge can pass through the meniscus in rotating He II.²¹

This result is consistent with the idea that a vortex line holds a charge at the meniscus until a thermal fluctuation sends it over the surface barrier. In the absence of vortex lines the charge would move along the surface and be collected at the vessel's walls before being ejected into the vapor.

C. Apparatus for Detection of Single Vortex Lines

According to theory (Sec. II), the critical angular velocity at which the first vortex line becomes stable is approximately inversely proportional to the square of the radius R . In a bucket 1 cm in diameter, ω_{c1} becomes so small (3×10^{-3} rad/sec) that we suspect random mechanical vibrations would have a great influence on the rotating system. If ω_{c1} is to be of the order of 1 rad/sec, then R must be approximately $\frac{1}{2}$ mm.

The basic apparatus used to detect single vortex lines is shown in Fig. 4. The small-diameter rotating bucket consists of carbon-resistance material. Bias voltages applied to various points produce electric fields in the vessel and control the carriers produced near the radioactive source S. Liquid helium at 1.2 K fills the lower 80% of the vessel, which opens directly into a proportional counter at its top.

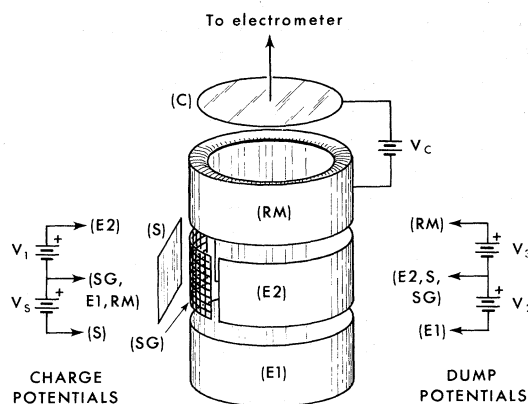

FIG. 3. Sketch of the cell used to study extraction of charge through the liquid meniscus. The liquid level is set near the top of the electrode RM.

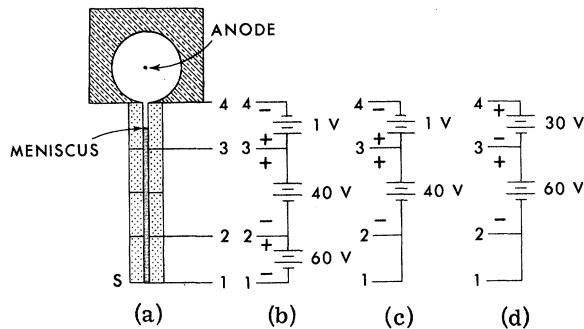

FIG. 4. Part (a) is a cross-section view of the basic apparatus used to detect single vortex lines. Diagrams (b)–(d) illustrate, respectively, the bias voltages used in the “charge,” “clear,” and “dump” parts of the cycle.

We constructed small-diameter buckets in the following way: A carbon resistor was faced off in a lathe until all traces of the wire leads were removed. Silver paint was applied to the ends of the solid cylinder, and a hole was drilled down the axis of the piece. When four such pieces were stacked, with their axes aligned, the long hole down the axis formed the narrow-diameter bucket. Two buckets, of radius 0.50 and 0.87 mm, were fabricated by this method. A radioactive source (0.75-Ci/cm^2 tritiated titanium) forms the bottom of the bucket. We apply bias voltages at the silvered ends of the sections to produce electric fields which control the motion of the charges within the bucket. If the room-temperature resistance of the carbon element is too small, thermal runaway occurs in the liquid helium when bias voltages of the order of 50 V are applied. For this reason 1- and 10-k Ω resistors were tested and eliminated. However, 100-k Ω 2-W Allen-Bradley resistors were found to be suitable.

We detect the vortex lines in a cycle which is repeated once every 30 sec. In the first (charge) part of the cycle, we apply an electric field which sweeps electrons away from the radioactive source and draws them along the axis of the bucket. As the electrons move through the liquid, some will be trapped on any vortex lines which are present; the remaining charge is collected at the walls near the top section, where a slight repelling field exists. After a 27-sec charging period, the field in front of the source is turned off so that no more charge leaves the source region. This (clear) configuration is maintained for about 2 sec to allow all untrapped charge to be collected at the walls. Finally, a (dump) field is applied in the top section, pulling the trapped charge up to the meniscus, where it leaves the liquid and enters the proportional counter. The anode current is integrated in an operational amplifier,²² which provides a pulse whose height is proportional to the total

charge collected. The output is filtered and recorded both in analog and digital (printed) form. Transitions in which the number of lines change should appear as steplike changes in the pulse height. After the charge is collected the biases are returned to the charging configuration, and the process repeats.

D. Proportional Counter

The proportional counter and assembled experimental cell are shown in Fig. 5. The proportional counter is made by drilling a hole (diameter 0.25 in.) in a rectangular brass block. The hole axis is parallel to the long axis of the block, but is displaced so that the hole center is 0.135 in. from one surface, giving a wall thickness of 0.010 in. between the inside of the counter and the top surface of the bucket. The brass block is surrounded by a Lucite form which provides electrical insulation between the brass cathode and the rest of the apparatus. The ends of the hole are closed by Lucite plates. A thin stainless-steel wire runs between small holes in the Lucite end plates; the wire runs down the axis of the hole in the brass block. This wire is the anode for the proportional counter. A 0.1-in.-diam hole in the side of the cathode is positioned over the top of the bucket. This forms the entrance to the detector for the electrons stripped off the vortex lines. Figure 6 shows a character-

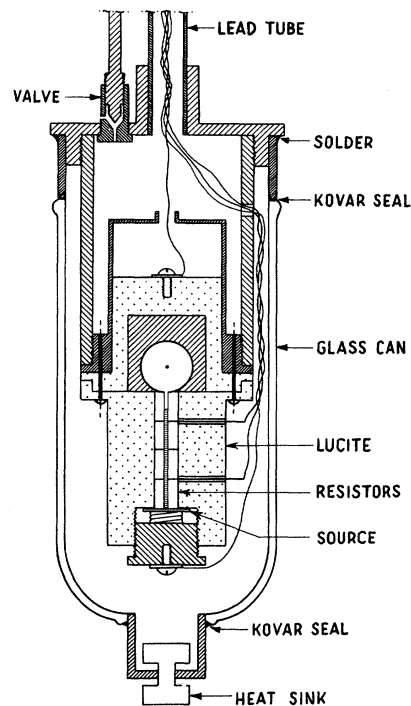

FIG. 5. Cross-section view of the assembled experimental cell.

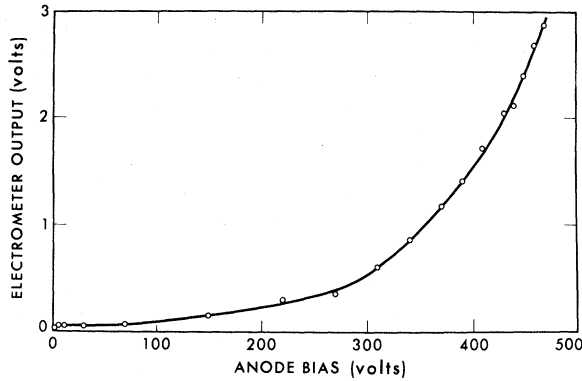

FIG. 6. Characteristic curve of a proportional counter operating in the vapor above a helium bath held at 1.2°K.

istic curve for such a device operating in the vapor above a 1.2-K bath of liquid helium. To obtain these points, we tried to inject a fixed amount of charge into the proportional counter and measure the charge reaching the anode. This was done in a helium-bucket apparatus (similar to that shown in Fig. 3) which was rotated rapidly enough so that many vortex lines would be present. We charged these lines for a fixed length of time, after which the charge was injected into the counter (which was biased at the potential V). The ordinate is the output signal from an electrometer which measured the collected anode charge. We measure gains with respect to the (presumably unity gain) plateau near 50 V.

Preliminary experiments with the proportional counter were necessary in order to learn how to use the device. It is difficult to find the optimum bias voltage between anode and cathode to give the maximum stable gain. If the bias is increased too far, a self-sustained discharge occurs and subsequently the counter breaks down at a much lower voltage. We do not know what causes this irreversible behavior. After such a discharge, the counter is disassembled, the cathode surface polished, and a new anode wire installed. Through trial and error we found that for our counter (0.003-in. anode wire, 0.25-in.-diameter cathode, 1.2-K helium vapor) 470 V was a good operating point, providing a stable gain of approximately 50, which seemed fairly reproducible from run to run.

Since it would have been desirable to have a detector which could count single electrons, we spent some time trying to operate the detector as a Geiger counter or a high-gain proportional counter. Unfortunately, no method was found for quenching the Geiger discharge which occurs for each count. We attribute this difficulty to the presence of metastable helium atoms or molecules which eject secondary electrons from the counter cathode. In fact, we found that at room temperature we could

make workable helium-filled Geiger counters (using an electronic-quenching technique),²³ if impurities were present in the gas. The impurities apparently serve to deexcite the metastable helium. Unfortunately, the vapor above liquid helium contains no such impurities.

E. Procedure

The experiment is controlled by circuits which determine the bias voltages in the cell and record the accumulated data. The cryostat starts from rest, is uniformly accelerated to speeds of a few rad/sec in several hours, and is then sometimes uniformly decelerated. Every 30 sec the "charge-clear-dump" cycle is repeated and the resulting collected charge is measured. Thus, in essence, we sample the state of the superfluid every 30 sec; the appearance of each vortex line should be heralded by a quantum jump in the collected charge.

IV. OBSERVATIONS AND INTERPRETATION

A. Detection of Single Vortex Lines

Figures 7-10 show typical data obtained using the apparatus described in Sec. III. We call attention to the following characteristic features:

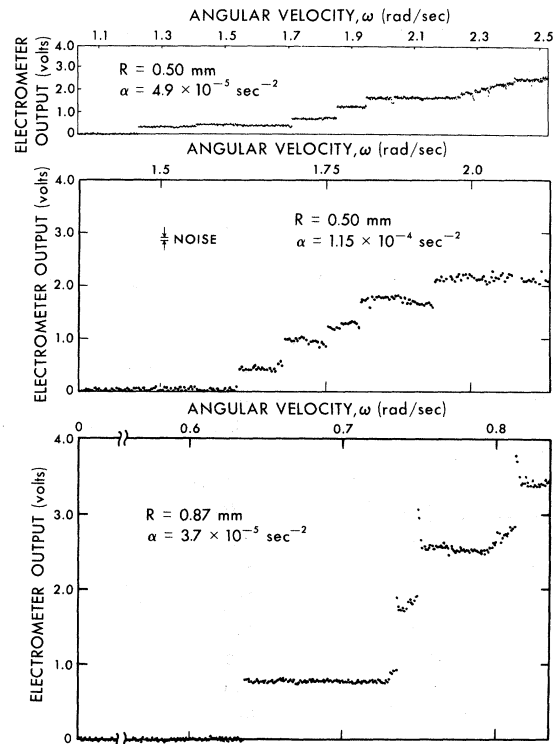

FIG. 7. Typical data obtained for different size vessels and different angular accelerations. In these data the first few steps are clearly seen. The acceleration is given by α .

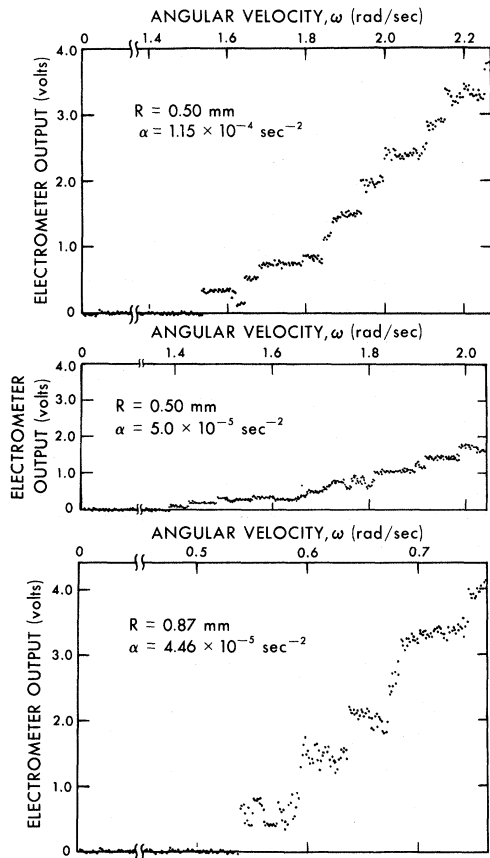

FIG. 8. Data showing structure more complicated than the simple steps shown in Fig. 7. The preparation of the liquid helium used for these data was nominally the same as used for the data shown in Fig. 7.

- (i) As the apparatus is accelerated from rest, there is no detectable signal below a characteristic angular velocity, at which it appears in a step-like manner.
- (ii) The angular velocity at which the first step appears is approximately three times larger in the bucket with 1.0-mm radius than in the one with radius 1.7 mm, agreeing with the predicted dependence of ω_{c1} on R .
- (iii) The angular velocity at which the signal appears is close (but not identical) to ω_{c1} calculated from the vortex-line theory of Sec. II.
- (iv) Increases in signal strength after the first step are generally also steplike in character, although more complicated behavior is also seen.

This is the behavior expected if each steplike increase in signal represents the contribution from a single vortexline. This observation seems to us to confirm rather directly a central prediction of the Onsager-Feynman quantized vortex model. The liquid helium is indeed found to come into rotation in a series of discrete events, not in continuous fashion. The critical angular velocities

do not agree quantitatively with those predicted by the equilibrium theory, as we will discuss further below, but this should not obscure the fact that a fundamental prediction of the Onsager-Feynman theory is strongly supported.

The value of ω_{c1} predicted by the theory of Sec. II is 1 rad/sec for $R = 0.50$ mm and 0.3 rad/sec for $R = 0.87$ mm. Inspection of the figures shows that the first step occurs at an angular velocity somewhat greater than the calculated ω_{c1} ; in deceleration a signal persists to angular velocities considerably less than ω_{c1} . We believe that the quantitative differences between observation and equilibrium theory are associated with barriers between metastable states, as discussed in Sec. II. In particular, if the first vortex is to be detected it must escape the strong attractive force which binds a "primordial" vortex to the walls. A large fluctuation is necessary to tear the line away from the wall so it may move out into the center. This idea is supported by the observation that a light tap on the cryostat, when $\omega > \omega_{c1}$, will produce a signal when none was present before. The tap presumably supplies the necessary energy to allow the system to move closer to equilibrium.²⁴

Upon deceleration (Fig. 9 is typical of all deceleration data), the signal persists to low speeds ($\omega < \omega_{c1}$). This hysteresis is probably caused by the energy barrier which tends to keep vortex lines away from the walls (which they must reach to be destroyed). A slight tap on the cryostat causes the signal to disappear if $\omega < \omega_{c1}$ or to change drastically at higher speeds. Upon deceleration, the signal decreases in a quasicontinuous fashion

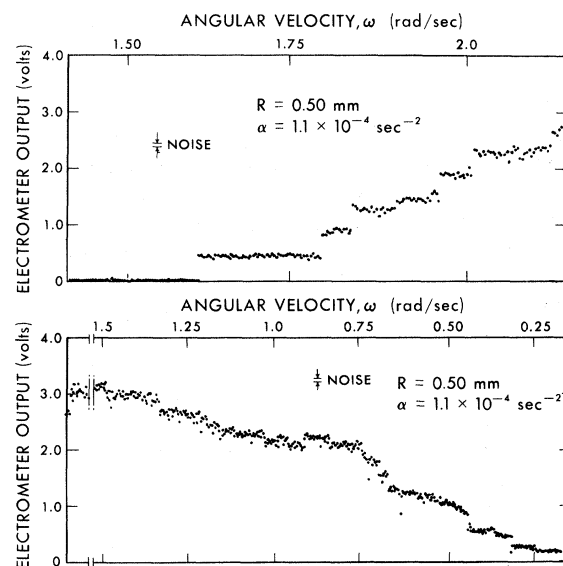

FIG. 9. Data showing the hysteresis in a complete acceleration-deceleration cycle.

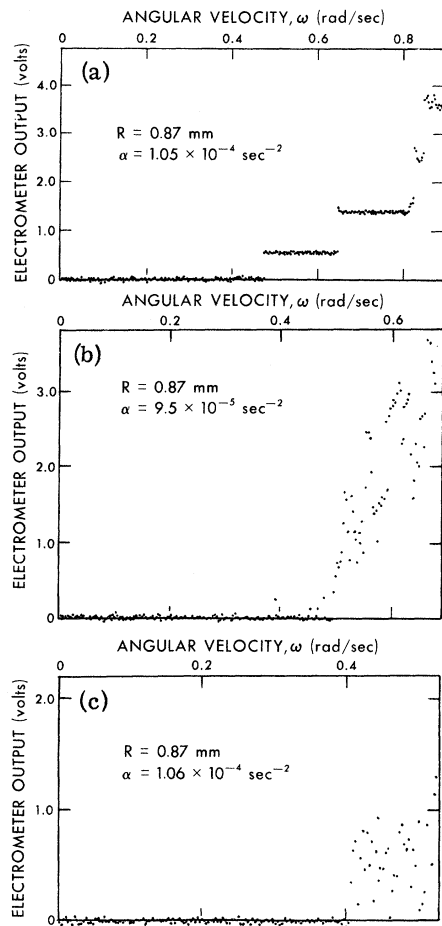

FIG. 10. Data showing history-dependent behavior of superfluid helium. The top data were obtained on the first rotation of the sample after cooling below the λ point; the lower sets were obtained on subsequent rotations below T_λ .

rather than with well-defined steps. This probably occurs because the energy barrier for a line to leave by a simple lateral displacement, is very large. Hence it is more favorable for the line to leave in a more complicated manner. From this point of view it is not clear why discrete steps occur on acceleration.

After the first few "steps" the level of fluctuations increases. This may be because the energy barriers between different metastable configurations decrease as the number of lines increases; thus the lines become more mobile. This increased freedom of the state of the system could produce the additional fluctuations. One could probably learn more about the fluctuations if it were possible to monitor the system on a short time scale rather than sample it once every 30 sec.

A striking effect which we observe is the exis-

tence of persistent vortex lines in a stationary container. This phenomenon is observed directly when a rapidly rotating container (diameter ~ 2 cm) is gently brought to rest—causing most of the signal due to the vortex lines to disappear. However, a small but easily detectable constant signal persists for as long as we had patience to wait ($\frac{1}{2}$ h). We believe this effect is caused by vortex lines pinned to high spots (bumps) on the bottom and side walls of the bucket. In order for a line to move off such a protuberance it must elongate. The energy per unit length of a vortex line is $\sim 10^9$ deg/cm; if only thermal fluctuations were available it is unlikely that a vortex line could become unpinned. This behavior is analogous to that of pinned flux lines in "dirty" superconductors,²⁵ and explains much of the history-dependence so often observed in experiments involving vortices in superfluid helium. This model of pinned vortices is supported by the observation that a gentle tap on the cryostat completely annihilates the persistent signal!

An example of history dependence which we attribute to pinned vortices is displayed in Fig. 10. The first set of data was obtained with a sample of helium in its first rotation below the λ point. The acceleration sequence shows four well-defined steps. After the first data were obtained, rotation was stopped, and the second acceleration was initiated approximately $\frac{1}{2}$ h later. Here, instead of well-defined steps, we see the signal building up in an incoherent manner with large fluctuations. Stopping the vessel again, waiting another $\frac{1}{2}$ h, and reaccelerating produces the third data set, which again shows no step structure. We interpret these data by assuming that the vortex lines, formed in the first rotation sequence, do not completely disappear when the vessel is stopped. (Since our method only detects lines which come to the free meniscus, we cannot detect a line whose upper end is pinned to a high spot on the wall.) When the vessel is accelerated the second and third time, these segments of pinned line move about in some complicated manner as the system seeks the most favorable state. If the system is warmed above the λ point and re-cooled, one generally obtains the clean steplike structure. If confusion is to be avoided in experiments dealing with vortex lines, the history of the sample must be known and controlled.

An unexpected result in these experiments is the observation that if the trapped electron bubble is forced to move faster than approximately 10 cm/sec the vortex lines seem to "shatter." Specifically we find that, if a signal due to vortex lines is present, a momentary increase in either the charging or dumping fields will cause the signal to disappear. If the speed of rotation is high enough

($\omega > \omega_{c1}$), the signal returns after several minutes and now resembles the data in Figs. 10(b) and 10(c) where there is no apparent relation between adjacent points. The field strength which causes this "shattering" is approximately 60 V/cm at 1.2 °K and increases at a higher temperature where the electron-bubble mobility is lower. Although we have not studied this phenomenon quantitatively it is appealing to think that perhaps vortex waves are created when the electron bubble surpasses a certain speed. Presumably, if the wave amplitude gets large, the line will break up. (We have not found any disturbance which propagates at the appropriate velocity.)

V. CONCLUSIONS

Although the work described in this paper is largely of an exploratory and qualitative nature, certain conclusions can be reached. First, we believe that it shows clearly that liquid helium does not come into rotation in a continuous fashion, such as would be expected for a classical fluid,

but does so in a series of quantum jumps. Thus the experiment gives clear experimental significance to the observation that in the superfluid systems one can observe quantum phenomena on the macroscopic scale. The experiment strongly supports the Onsager-Feynman picture of rotating liquid helium, in which classical rigid rotation is simulated by an array of quantized vortex lines. It is further shown that in a real macroscopic apparatus, the actual state of the rotating superfluid can be quite different from the *equilibrium* state calculated from the quantized vortex picture. Some information about the nature of the nonequilibrium states is obtained, including evidence of the importance of vortex pinning.

The experiments show the usefulness of trapped electrons as detectors of single vortex lines, and raise the possibility of other interesting experiments. It may be possible to use similar techniques to obtain information about the spatial arrangement of the vortices. We are presently pursuing this possibility.

*Research supported by the United States Atomic Energy Commission and the National Science Foundation.

†Present address: Physics Department, University of California, Berkeley, Calif. 94720.

¹L. D. Landau, *J. Phys. USSR* **5**, 71 (1941).

²E. L. Andronikashvili, *Zh. Eksperim. i Teor. Fiz.* **18**, 424 (1948).

³D. V. Osborne, *Proc. Phys. Soc. (London)* **A63**, 909 (1950); R. Meservey, *Phys. Rev.* **133**, A1472 (1964).

⁴E. L. Andronikashvili and I. P. Kaverkin, *Zh. Eksperim. i Teor. Fiz.* **28**, 126 (1955) [*Sov. Phys. JETP* **1**, 174 (1955)].

⁵L. Onsager, *Nuovo Cimento Suppl.* **6**, 249 (1949).

⁶R. P. Feynman, in *Progress in Low Temperature Physics*, edited by C. J. Gorter (North-Holland, Amsterdam, 1955), Vol. 1, Chap. 2.

⁷For a review of the rotating helium problem, see E. L. Andronikashvili and Yu G. Mamaladze, *Rev. Mod. Phys.* **38**, 572 (1966). This article is also available in *Ref. 6*, Vol. 5, Chap. 3; also see W. F. Vinin, *ibid.*, Vol. 3, Chap. 1.

⁸G. B. Hess and W. M. Fairbank, *Phys. Rev. Letters* **19**, 216 (1967).

⁹A preliminary account of this work has been given in Richard E. Packard and T. M. Sanders, Jr., *Phys. Rev. Letters* **22**, 823 (1969).

¹⁰For a review of ions and vortices see R. J. Donnelly, *Experimental Superfluidity* (University of Chicago Press, Chicago, 1967). Also see F. Reif, in *Quantum Fluids*, edited by N. Wiser and D. J. Amit (Gordon and Breach, New York, 1970), Chap. 10.

¹¹R. L. Douglass, *Phys. Rev. Letters* **13**, 791 (1964);

W. P. Pratt, Jr. and W. Zimmermann, Jr., *Phys. Rev.* **177**, 412 (1969).

¹²R. L. Douglass, *Phys. Rev.* **174**, 255 (1968); William I. Glaberson, *J. Low Temp. Phys.* **1**, 289 (1969).

¹³G. B. Hess, *Phys. Rev.*, **161**, 189 (1967).

¹⁴A. L. Fetter, *Lectures in Theoretical Physics*, edited by K. T. Mahanthappa and W. E. Brittin (Gordon and Breach, New York, 1969), Vol. XI, p. 321.

¹⁵L. D. Landau and E. M. Lifshitz, *Statistical Physics* (Addison-Wesley, Reading, Mass., 1958), Sec. 26.

¹⁶In evaluating this function, and elsewhere in this paper, we have used $a = 1.0 \text{ \AA}$ in numerical calculations.

¹⁷L. J. Campbell, in *Proceedings of the 12th International Conference on Low Temperature Physics*, edited by Eizo Kando (Academic Press of Japan, Tokyo, 1971), p. 77.

¹⁸The apparatus is described in more detail by Richard E. Packard, Ph.D. thesis (University of Michigan, 1969) (unpublished).

¹⁹Graham Transmissions, Inc., Menomonee Falls, Wisc. (model 28A).

²⁰L. Bruschi, B. Maraviglia, and F. E. Moss, *Phys. Rev. Letters* **17**, 682 (1966); G. Careri, V. Fasoli, and F. S. Gaeta, *Nuovo Cimento* **15**, 774 (1960).

²¹Similar results have been obtained by W. Schoepe and K. Dransfeld, *Phys. Letters* **29**, 165 (1969).

²²Analog Devices, Inc., Cambridge, Mass., model 301.

²³Electronic quenching is described by S. A. Korff, *Electron and Nuclear Counters* (Van Nostrand, New York, 1955), Chap. 7.

²⁴A striking example of this metastability is seen by J. D. Reppy and C. T. Lane, *Phys. Rev.* **140**, A106 (1965).

²⁵P. W. Anderson, *Phys. Rev. Letters* **9**, 309 (1962).