

Stochastic and deterministic absorption in neutron-interference experiments

J. Summhammer, H. Rauch, and D. Tuppinger

Atominstytut der Österreichischen Universitäten, Schüttelstrasse 115, A-1020 Wien, Austria

(Received 13 April 1987)

Experiments with absorbing foils, beam choppers, or an absorbing lattice in one path of a neutron interferometer to expose the difference between stochastic and deterministic absorption in quantum mechanics are reported. The different amplitudes of the interference patterns in stochastic and deterministic absorption when the absorption probability is the same were observed in agreement with prediction. Also the possibility of a gradual transition from deterministic to stochastic absorption was experimentally investigated.

I. INTRODUCTION

The neutron interferometer (IFM) is a device that allows the division of an incident beam of thermal neutrons, the separate manipulation of the two resulting beams, and their subsequent superposition. Its beam geometry is similar to that of the Mach-Zehnder arrangement known in optics. As beam splitter and as mirrors, slabs of single-crystal silicon with a common base are used, and the physical principle employed is Bragg reflection in the Laue configuration. With this IFM, in which the two beams are separated by a few centimeters, a number of investigations on the quantum-mechanical superposition principle for neutrons as well as precision measurements of neutron-nucleus scattering lengths have been performed in recent years.^{1,2}

The problem of interest here can be stated as follows: What is the quantitative effect on the interference pattern when one of the neutron beams inside the IFM is attenuated? The attenuation of the beam is achieved by absorption of some of the neutrons in one path of the IFM. Those which are absorbed cannot contribute to the interference pattern recorded behind the IFM. But is there an effect on those neutrons which went through the absorber region unabsorbed? Quantum theory predicts such an effect under certain circumstances. In particular, there is a difference between stochastic absorption—when the experimenter has no means, not even in principle, to predict whether the neutron will be absorbed or not at any given point in the absorber region at any given time—and deterministic absorption—when in principle it is known with certainty what will happen at any point in the absorber region at any time, if a neutron happens to be there. As has been pointed out,³ this difference persists even when the mean probability of a neutron to be absorbed is the same.

To clarify this question the following experiments with absorbers present in one of the paths of the IFM were performed.

Absorption by a partially absorbing foil.

Absorption by a chopper which periodically closed and opened the beam.

Absorption by a one dimensional absorbing lattice.

The first experiment intended to show the effect of stochastic absorption, the second that of deterministic absorption, and the third tried to show the possibility of gradually going from one situation to the other. A short report on the results of the first two experiments has been published earlier.⁴

II. THEORY

Each of the two beams behind the IFM can be described as a superposition of two wave functions which represent the left and the right beam paths inside the IFM, respectively. Since the probability of finding two or more neutrons inside the IFM at any given time is extremely low with all available neutron sources, one can use a single-particle wave function. Ordinarily it is sufficient to represent the two beams by plane waves whose wavelength may be taken as the average wavelength of the fairly monochromatic incident beam. Also, as the intensity changes at the *H* detector are always complementary to those at the *O* detector, a detailed calculation of the intensities at both detectors is not needed. For the sake of simplicity, only the forward beam leading to the *O* detector will be considered (Fig. 1). The wave function at the *O* detector can be written, up to a phase factor,

$$\psi_0 = \psi_{0L} + \psi_{0R} e^{i\chi}, \quad (1)$$

where ψ_{0L} , ψ_{0R} are the wave functions corresponding to the left and the right paths inside the IFM, for the empty IFM. χ is the relative phase shift caused by the usual phase plate for establishing the interference pattern. It is given by⁵

$$\chi = -\lambda N \Delta D \sqrt{b_c^2 - (\sigma_r/2\lambda)^2} + \frac{1}{2} i \sigma_r N \Delta D, \quad (2)$$

where $\lambda = 2\pi/k$ is the wavelength of the neutron, N is the density of nuclei, ΔD is the difference in thickness of the phase plate as seen along the left and the right beam paths, and σ_r is the reaction cross section including absorption and incoherent scattering processes ($\sigma_r = \sigma_a + \sigma_i$). b_c is the coherent neutron-nucleus scattering length.

The complex part of χ is seen as absorption by the IFM. In particular, scattering out of the beam direction between the first and the second crystal plate represents

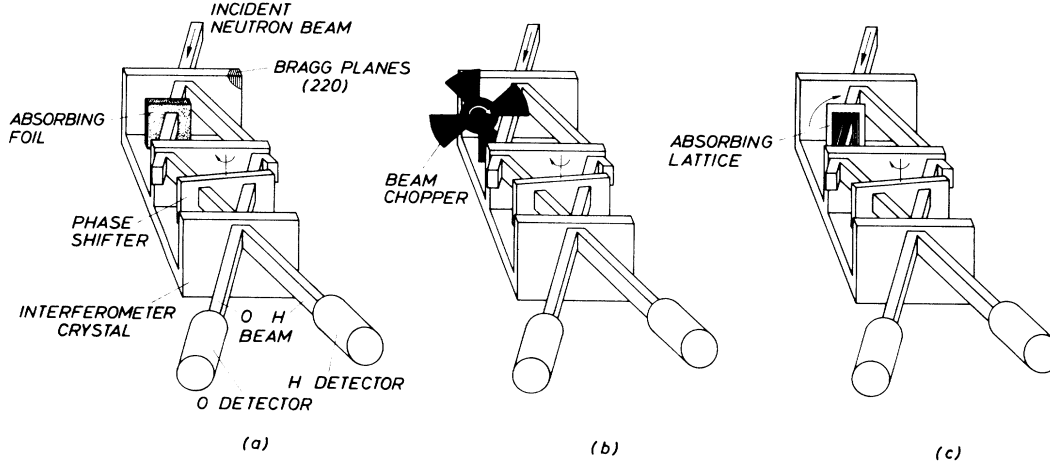

FIG. 1. Setup for the experiments with three different kinds of absorbers in the left beam path. The size of the Si single-crystal IFM is about $9\text{ cm} \times 6\text{ cm} \times 6\text{ cm}$. The cross section of the incident beam varied in between $2\text{ mm} \times 10\text{ mm}$ and $4\text{ mm} \times 5\text{ mm}$. (a) With gold or indium foils as absorbers. (b) With beam chopper. (c) With a one-dimensional cadmium lattice as absorber. The lattice could be rotated to different angles as indicated by the arrow, to give different effective lattice constants.

a loss of neutrons too, since these will not be present in either the O or the H beam due to the extremely narrow angular acceptance for reflectivity at the next crystal plate of the IFM (about six microradians for $\lambda = 2\text{ \AA}$). In the usual aluminum phase plate σ_r can be neglected, so that the phase shift is real. From now on it will be denoted by ϕ ,

$$\phi = -N\lambda b_c \Delta D. \quad (3)$$

Then, for a perfect IFM, where $\psi_{0L} = \psi_{0R}$, one obtains for the intensity at the O detector as a function of ϕ

$$I_0(\phi) = 2 |\psi_{0R}|^2 (1 + \cos\phi). \quad (4)$$

Rotation of the phase plate changes ΔD and thus ϕ and so gives the well-known intensity oscillation.

When in addition to the phase plate a partially absorbing foil of thickness L is inserted into the left beam path [Fig. 1(a)] the wave function of this beam at the O detector becomes

$$\psi'_{0L} = e^{-\sigma_r NL/2} \exp\{-i\lambda NL [b_c^2 - (\sigma_r/2\lambda)^2 \psi_{0L}]\}^{1/2}, \quad (5)$$

where σ_r , N , and b_c are the above-defined quantities but corresponding to the absorbing foil. The factor

$$a = |e^{-\sigma_r NL/2}|^2 \quad (6)$$

can be identified as the transmission probability of a neutron along the left beam to the O or the H detector, once the neutron has taken the left beam. It will be called transmission probability along the left beam, for short. A more detailed discussion of the effective attenuation factor can be found in Ref. 6. If scattering in the foil can be neglected it is equivalent to the probability of a neutron to passing the foil and not being absorbed. The real part of the phase shift in the foil is an experimental constant and will be neglected here. But as seen from Eq. (5) it depends on b_c and λ , so that a detailed study

of the nuclear-reaction mechanism is possible by measuring it in the IFM.^{7,8} For the present purpose one can write as the effect of the absorbing foil

$$\psi'_{0L} = \sqrt{a} \psi_{0L} \quad (7)$$

and for the intensity at the O detector

$$I'_0(\phi) = |\psi'_{0L} + \psi_{0R} e^{i\phi}|^2 = |\psi_{0R}|^2 (1 + a + 2\sqrt{a} \cos\phi). \quad (8)$$

On the other hand, when a slow beam chopper of transmission probability a is inserted instead of the partially absorbing foil [Fig. 1(b)], the expectation for the intensity at the O detector is

$$I''_0(\phi) = a |\psi_{0L} + \psi_{0R} e^{i\phi}|^2 + (1-a) |\psi_{0R}|^2 \\ = |\psi_{0R}|^2 (1 + a + 2a \cos\phi). \quad (9)$$

Here—under the assumption of a stationary incident beam—the intensities for the two possible chopper states have to be added; if the transmission of the chopper is a , then for a fraction a of the total measuring time the neutrons see a normal IFM with both beam paths open and for a fraction $(1-a)$ of the total measuring time only the right beam path is open, because the left beam path is completely blocked. (The assumption of an ideal beam chopper is made here; the beam is either totally undisturbed or completely absorbed.)

On comparing Eqs. (8) and (9) the different amplitudes of the interference pattern are noticed. It is either proportional to the transmission probability along the left beam, a , or to its square root, \sqrt{a} , although in both cases the same number of neutrons are absorbed and thus taken away from possible interference. This is how the difference between stochastic and deterministic absorption manifests itself. But for equal transmission probability a one finds, of course, that the mean intensity is the same for both cases. One aim of the present work is to explicitly demonstrate these effects.

As a third possibility the effect of a one-dimensional macroscopic lattice, which is fully absorbing at the lattice sites and fully transparent in between, was investigated [Fig. 1(c)]. This lattice, just as the chopper, represents a case with deterministic absorption. Actually the reason for this experiment was that such a lattice could simulate what happens in the experiment with the chopper, when the chopper becomes very fast in rotation.

As an explanation for the smaller interference pattern in the case of the chopper one will guess that it is the memory of the chopping which is imprinted on the wave function of the left beam that in principle makes it possible to tell for some of the neutrons along which path they have gone through the IFM, and that those "labeled" neutrons do not contribute to the interference pattern. But if they do not contribute to it, one expects that the interference pattern will remain unchanged, if somehow one eliminates them before they can reach the *O* or the *H* detector. On the other hand, eliminating the labeled neutrons is equivalent to reducing the transmission probability along the left beam, although the transmission through the chopper itself remains the same. Therefore the amplitude of the interference pattern as a function of the transmission probability along the left beam will increase. If all labeled neutrons were eliminated the amplitude of the interference pattern would again be proportional to the square root of the transmission probability along the left beam, just as in the case with the foil absorbers. This would reflect the fact that no information about the time structure of the chopping is contained in the beams at the *O* or the *H* detector. Of course, the amplitude of the interference pattern as compared to the empty IFM would be reduced. But from this one could only deduce that one of the beams inside the IFM is attenuated in a stochastic way.

It was the aim of the experiment sketched in Fig. 1(c) to illustrate these effects. There, instead of a fast chopper, a one-dimensional absorbing lattice with its reciprocal lattice vector parallel to the reciprocal vector of the Bragg plane chosen for the IFM is used. While a fast chopper creates out of an incident plane wave a spectrum of plane waves with different energies due to the time structure of the chopping and in practice also with different directions of momentum due to diffraction at the edges of the chopper blades, this absorbing lattice creates out of an incident plane wave a spectrum of plane waves with unchanged energy but different directions of momentum. In each case the spectrum of labeled neutrons contains the structural information, because in principle from a complete measurement of the energy and momentum spectrum the reconstruction of the time and space structure of the absorber through which the neutrons have gone is possible. At least this is possible for the periodic chopper or lattice considered here.

It will now be analyzed how labeled neutrons can be eliminated before reaching the *O* or the *H* detector. It turns out that for a sufficiently narrow absorbing lattice, or for a sufficiently fast chopper, the elimination of la-

beled neutrons may automatically be performed by the two crystal plates of the IFM which follow along the left beam. This is in fact easier than to filter out the labeled neutrons behind the IFM, because the reflection-transmission probability at the second and third crystal plates is very sensitive to changes of momentum or energy that occur after the first crystal plate. These changes can be measured practically independent of the width in energy and momentum of the incident beam.^{9,10} This was important here, where the spectral width of momenta behind the lattice resulting from an incident plane wave was orders of magnitude smaller than the width in momentum of the incident beam. The processes at the second and third crystal plate can now be understood as follows.

The absorbing lattice has a periodicity s , with completely absorbing sections of width $s-l$ and fully transparent sections of width l . The probability of a neutron to pass the lattice is thus l/s . If before the lattice the left beam is described by a plane wave, then the wave function behind the lattice is a superposition of plane waves of equal absolute values of momentum but different directions of momentum. The momentum components parallel to the reciprocal vector of the lattice, k_{\parallel} , are quantized in multiples of h/s . Neutrons which change their momentum state when passing the lattice become labeled neutrons.

Now the reflection probability for a plane wave at the subsequent crystal plate is given by

$$r(k_{\parallel}, k_{\perp}) = \sin^2 \left[\frac{G}{2k_{\perp}} \frac{D}{\Lambda} [1 + \Lambda^2(k_{\parallel} - G/2)^2]^{1/2} \right] \times [1 + \Lambda^2(k_{\parallel} - G/2)^2]^{-1} \quad (10)$$

with

$$\Lambda = \frac{\hbar^2 G}{2m |V_G|}, \quad (11)$$

where D is the thickness of the crystal plate, G is the size of the reciprocal lattice vector \mathbf{G} of the Bragg plane, k_{\parallel} is the component of the wave vector of the incident plane wave which is parallel to \mathbf{G} , and k_{\perp} the component normal to \mathbf{G} . V_G is the Fourier component of the crystal potential seen by the neutrons which is periodic along \mathbf{G} , and m is the mass of the neutron. The quantity $\Lambda(k_{\parallel} - G/2)$ is called the Selektionsfehler,¹⁰⁻¹² as it describes the deviation of the incident wave from the exact Bragg condition. Λ is a length containing only crystal parameters. Its inverse $1/\Lambda$ thus sets the physical scale of how much k_{\parallel} may deviate from $G/2$ to still have appreciable reflection probability at the crystal.¹³ For the 220 plane of a silicon crystal, $\Lambda = 12.6 \mu\text{m}$.

At the second crystal plate the following may happen: those components of the wave function with k_{\parallel} different from that of the incident plane wave do not fulfill the Bragg condition at that crystal plate and thus are not reflected. A corresponding fraction of neutrons will then not be part of the left beam behind that crystal plate and consequently also not at the *O* or the *H* detector. How-

ever, it is also possible that an incident plane wave that barely fulfilled the Bragg condition at the first crystal plate and would thus also be mainly transmitted at the second, results in a spectrum of plane waves behind the lattice which to a large degree do fulfill the Bragg condition at the second crystal plate, so that relatively more labeled neutrons will be in the left beam behind the second crystal plate than unaffected neutrons. Then there is still a chance that the third crystal plate will act as a filter. There the labeled neutrons are reflected with a probability $r(k_{\parallel}, k_{\perp})$ which oscillates strongly with varying k_{\parallel} . Thus it may happen that a larger fraction of labeled neutrons go into the O beam than go into the H beam, or vice versa, so that the transmission probability along the left beam measured at the O detector can be very different from that measured at the H detector. Wherever it is smaller, there will be fewer labeled neutrons relative to the unaffected ones, which means that some information about the structure of the absorbing lattice is lost. The amplitude of the interference pattern with respect to the transmission probability should therefore increase. Roughly this increase should be stronger if s gets smaller, as then the spectrum of k_{\parallel} behind the lattice gets wider, and the reflection probability for the labeled neutrons will on the mean be smaller than that of the original plane wave [Eq. (10)].

Formally a neutron behind the lattice in a state with a certain k_{\parallel} and k_{\perp} has a probability $r^2(k_{\parallel}, k_{\perp})$ to arrive at the O detector and a probability $r(k_{\parallel}, k_{\perp}) - r^2(k_{\parallel}, k_{\perp})$ to arrive at the H detector. A detailed calculation that takes into account the actual thicknesses of the crystal plates as well as the finite spectral width of the incident beam shows that with the arrangement as sketched in Fig. 1(c) it is only possible to eliminate labeled neutrons from the H beam at the expense of diverting them to the O beam. Thus only at the H detector could we expect to observe the increase of the amplitude of the interference pattern relative to the transmission probability along the left beam. A more detailed account of the effect of the absorbing lattice is given in the Appendix.

III. EXPERIMENTAL

The experiments were performed at the IFM facility of the Institut Laue Langevin in Grenoble. For the experiments with the foil and the chopper absorbers a symmetric triple Laue IFM as shown in Fig. 1 was used, whereas for those with the absorbing lattice a skew symmetric triple Laue IFM (Ref. 14) was used. Both interferometers use the same Bragg plane (220) and function in exactly the same manner. For the foil and the chopper experiments the incident neutron beam had an average wavelength of $\lambda = 1.974(6)$ Å with a wavelength spread of $\Delta\lambda/\lambda = 1\%$. An aluminum plate of 5 mm thickness with negligible absorption was used as a phase shifter in all experiments (Fig. 1). The absorbing foils consisted of 1-mm-thick flat slabs of gold and indium. By stacking between one and five of such slabs of either gold or indium and inserting them into the left beam such that the slabs were parallel to the crystal plates, the transmission probability along the left beam could be

varied between 0.9% and 48.0%. Figure 2(a) shows a typical data set.

For the chopper experiments three different choppers with transmission probabilities of 25%, 50%, and 75% were used along the left beam. The chopper consisted of a rotating disk of 1-mm-thick cadmium with a diameter of 70 mm, where the necessary number of octant sections were cut out. The closed position ensured an absorption probability of better than 99.99%. The open-closed frequency was either 8 or 16 Hz. The measuring time for the intensities was always an integral multiple of the chopper period. The chopper rotated inside an aluminum chamber to protect the IFM from vibrations. Figure 2(b) shows a typical data set.

In the experiments with the absorbing lattice an incident neutron beam with an average wavelength of $\lambda = 1.924(6)$ Å was used. Again one had $\Delta\lambda/\lambda = 1\%$. From Eq. (10) it can be seen that the lattice constant should be on the order of magnitude of Λ . The lattice was made of cadmium strips of 2 mm width, 30 mm length, and a thickness of 50 μm . The strips were stacked with a distance of 20 μm between them to give a lattice with s being 70 μm . The form of the lattice was thus rather like that of a slit collimator. Therefore it could only be inserted into the left beam in such a way that the beam was perpendicular to the lattice plane. This gave a reduction of the effective lattice period with respect to the reciprocal lattice vector of the Bragg plane by a factor 0.87. Furthermore, the lattice could be rotated around the direction of the left beam as indicated in Fig. 1(c). Since only the periodicity of the absorbing lattice along the direction of the reciprocal vector of the Bragg plane is important, one could thus adjust the lattice period between a minimum value and infinity (that is, wider than the beam). The effective minimum value of s was 61 μm . To achieve the same experimental

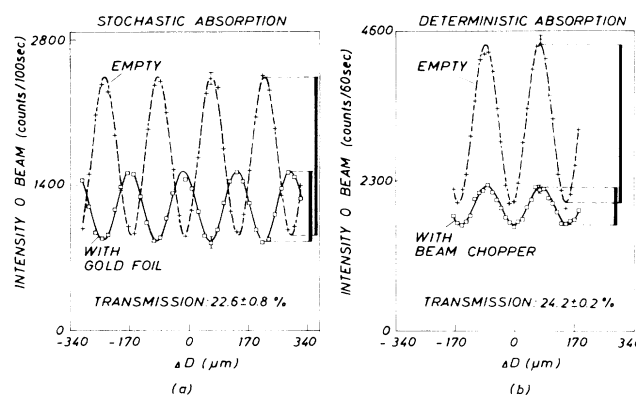

FIG. 2. (a) Data and least-squares fits of interference pattern at the O detector obtained by rotating the phase shifter, with and without a gold foil absorber in the left beam. (b) as (a), but with and without a beam chopper in the left beam. Graphs are drawn such that the interference patterns without any absorber appear with the same size in both cases. With the absorbers in the beam the mean transmission along the beam through the absorber region is about the same, but the amplitude of the interference pattern is quite different.

result as with the lattice at this minimum, the open-closed frequency of a chopper would have had to be around 26 MHz.

The transmission probability of neutrons along the left beam was measured in the same way for all three kinds of absorbers: the right beam path of the IFM was blocked and then the intensities at the O and the H detector were recorded with the absorber present in the left beam and without it. With a small correction for background the quotient of the two intensities gave the transmission probability along the left beam. For the foil and the chopper absorbers this effective transmission probability was the same at the O and at the H detector, but it was generally different for the lattice absorber, this being consistent with earlier analytic arguments. Also, as was intended, the transmission probability along the left beam measured at either the O or H detector was different for different settings of the effective lattice constant s of the Cd lattice. This was due to the different number of labeled neutrons being filtered out at the second crystal slab. The transmission of the Cd lattice itself decreased slightly with increasing s , because the vertical dispersion of the left beam was reduced.

IV. RESULTS

In the analysis of the data the amplitude of the interference pattern was obtained from least-squares fits. However, in the case of the foil absorbers an additional correction had to be applied that took into account the reduction of the interference pattern due to the wavelength-dependent real phase shift in the foils and the wavelength spread of the incident beam. Especially for the gold foils the true amplitude of the interference pattern was thus larger by a few percent than found in the least-squares fits.^{15,16} Typical data sets and the corresponding least-squares fits are seen in Figs. 2(a) and 2(b) for the foil and the chopper experiments. The graphs are drawn such that the amplitude of the interference pattern with the empty IFM appears the same in both cases. But one sees that with the gold foil absorber in the left beam the amplitude of the interference pattern is very different from that when the chopper is in the left beam, although the transmission probability along the left beam was approximately the same in both cases. In fact, the transmission was somewhat smaller for the foil absorber and yet the resultant amplitude of the interference pattern is almost twice that of the chopper absorber. One also notices that for the empty IFM the fringe contrast, that is, the amplitude of the interference pattern relative to the mean value of the intensity, is different in the two cases. The reason is that the cross section of the incident beam was wider in the chopper experiment, and the beam also hit another spot of the crystal, so that different parts of the crystal slabs were actually used in the two experiments. Since there are imperfections in the crystal this generally means different transmission-reflection properties even within parts of the area of the beam. Normally with a wider incident beam the amplitude of the interference pattern thus increases less than the mean intensity. Therefore it

was important in all experiments with absorbers to record an interference pattern with the empty IFM immediately before or after the recording with the absorber, or, as was done with the foil absorbers, by measuring intensities for each position of the phase shifter with and without the absorber. In order to compare the amplitudes of the interference patterns obtained with different absorbers one thus had to use the amplitude of the interference pattern normalized to that of the empty IFM.

In Figs. 3(a) and 3(b) these results are plotted for the different kinds of absorbers together with the theoretical expectation for the stochastic and deterministic cases, as a function of the transmission probability along the left beam. The results for the foil absorbers follow closely the square-root behavior, while those for the chopper absorbers follow the linear dependence. It should be mentioned that the surprisingly large amplitude of interference for the foil absorbers with small transmission is also evident in other neutron interferometry experiments where the scattering length of absorptive materials was studied.^{7,8} The results for the lattice absorber lie somewhere between the square-root dependence and the linear dependence, at least for the H detector, which is also in agreement with the quantum-mechanical prediction. One notes that the transmission probability along the left beam as measured at the H detector increased with increasing effective s . As mentioned above, the transmission of the lattice itself decreased with increasing effective s . The filtering out of labeled neutrons is thus nicely demonstrated. The numerical values of the results are listed in Table I.

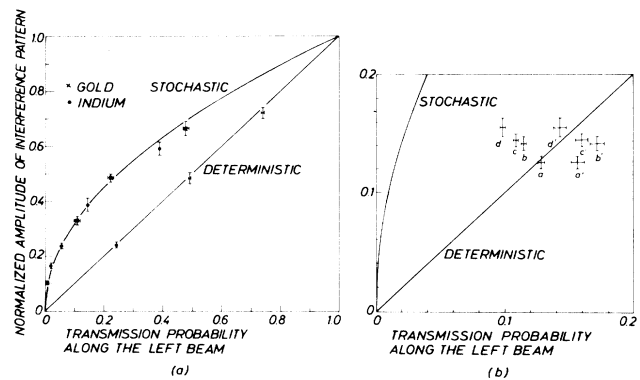

FIG. 3. Normalized amplitude of interference pattern as a function of transmission probability through the left beam. Fully drawn lines: expectation for stochastic and deterministic absorption, respectively. (a) The points for the foil absorbers in the left beam follow closely the curve for stochastic absorption, whereas those for the chopper absorber follow the straight line for deterministic absorption. (b) With the lattice absorber in the left beam. The points labeled a–d correspond to the results at the H detector with the lattice absorber rotated such that the effective lattice constant was ∞ , 244 μm , 122 μm , and 61 μm . Those labeled a'–d' correspond to the results at the O detector.

TABLE I. Results for transmission probabilities along the left beam and normalized amplitudes of interference pattern.

Absorber	Transmission probability along the left beam ^a	Normalized amplitude of interference pattern ^b
1 slab gold	0.4790(87)	0.665(27)
2 slabs gold	0.2264(82)	0.487(16)
3 slabs gold	0.1086(81)	0.328(15)
4 slabs gold	0.0547(81)	0.230(13)
5 slabs gold	0.0255(81)	0.141(10)
1 slab indium	0.3893(33)	0.592(24)
2 slabs indium	0.1470(16)	0.387(24)
3 slabs indium	0.0572(9)	0.237(9)
4 slabs indium	0.0218(4)	0.167(8)
5 slabs indium	0.0088(4)	0.102(7)
Chopper 1	0.242(10)	0.253(14)
Chopper 2	0.486(12)	0.498(17)
Chopper 3	0.685(14)	0.666(20)
Lattice $s = 61 \mu\text{m}$	0.0984(19) at H 0.1429(46) at O	0.1556(81)
Lattice $s = 122 \mu\text{m}$	0.1092(18) at H 0.1599(43) at O	0.1445(57)
Lattice $s = 244 \mu\text{m}$	0.1149(22) at H 0.1713(53) at O	0.1414(59)
Lattice $s = \infty$	0.1284(24) at H 0.1564(51) at O	0.1255(53)

^aEqual at O and H detectors for foil and chopper absorbers.

^bAlways equal at O and H detectors.

V. DISCUSSION

The different amplitudes of the interference pattern for the foil and the chopper absorber for cases where the transmission probability along the left beam is the same cannot be comprehended when one thinks of absorption as just taking some neutrons out of the beam independent of how this is achieved. It is easier to see the difference between the two experiments when one considers what one knows of a given neutron that has just been detected at the O or the H detector. Before proceeding, however, it shall be emphasized that in the following the classical language about a neutron's path inside the IFM is used only to illustrate the results. To be specific, the path of a neutron, or the beam along which a neutron has gone, will mean one of those two distinct regions inside the IFM, where, according to the knowledge of the whole experimental setup, the neutron could have been detected with a certain probability, had one cared to measure that. It is quite clear that when observing interference, knowledge of the path of a neutron inside the IFM must remain uncertain in a very rigorous sense: the concept of a neutron having gone along the one or the other path cannot be applied.

With the foil absorber in the left beam one knows that the neutron has either gone along the right beam or— with a somewhat reduced probability—along the left beam. The more certain one is about the path, that is, the stronger the absorption in the left beam, the smaller the interference pattern. This information is the same for all neutrons one detects at either the O or H detector. It is surprising that, if one knows that the neutron

has gone with, say, 99% probability along the right path, the amplitude of the interference pattern is still about 10% of the value it takes when the neutron had equal chance to have gone along either beam. In particular it is worth noting that the amplitude of the interference pattern can be bigger by an arbitrarily large factor than the intensity of neutrons having come along the left beam. (A quantitative discussion of this phenomenon, but in terms of the double-slit experiment, can be found in Ref. 17.)

With the chopper absorber in the left beam one knows that, if the chopper was open when the neutron could have passed there, then the neutron has seen an empty IFM and has thus had the same chances of having gone through the left or the right beam as in the empty IFM (which are ideally equal), or, if the chopper was closed when it could have passed there, then it can only have come along the right beam. In other words, it is not important to know when a neutron may have been in the chopper region, but that what happens when it is in the chopper region is certain. One should point out that this information stays the same when instead of a periodic chopper an intrinsically random one is used, e.g., when the open-closed mechanism is controlled by an external radioactive source. Therefore one would then expect the same linear dependence of the amplitude of the interference pattern on the transmission probability along the left beam. This follows, although it might seem that the principle unpredictability is the same, whether a nucleus in the gold foil “decides” to absorb a given neutron or some other nucleus decides to decay just then and trigger the blocking of the beam.

In the case of the chopper—a deterministic absorber—one has more detailed information about a neutron's possible path in the IFM than in the case of the foil—a stochastic absorber. This is reflected in the lower amplitude of the interference pattern. Thus "partial lack of information about each neutron's path is not equivalent with no lack of information for a fraction of the neutrons and total lack of information for the others."¹⁸ In this view the chopper experiment actually consists of two separate experiments whose results are added with the appropriate weights.

But of course the same result follows when one takes the correct time-dependent wave function which appears immediately behind the chopper as rectangular wave packets. This view was taken here and made it possible to simulate a fast chopper by an absorbing lattice. This allows one to associate the information on two separate groups of neutrons—that some neutrons are definitely absorbed while others pass definitely unaffected—with information on a single neutron, which is then the same for all neutrons. What one then knows about the individual neutron is, as expressed by the proper wavefunction, that if it passes along the left beam path, it has a certain time-independent probability of being absorbed, an equally time-independent probability of passing through the chopper region unaffected, and also a time-independent probability of going to one of the higher or lower quantized energy states with respect to its original energy state, thus becoming a labeled neutron. (Diffraction at the edges of the chopper blades is neglected here.) The probabilities are time independent, since with the stationary incident beam the probability of finding a neutron anywhere along the beam before the chopper is also time independent. The labeled neutrons carry the path information, as one knows that they can only have come along the left beam, and one could filter them out by measuring the energy behind the IFM. Therefore they do not contribute to the time-averaged interference pattern which was measured here. This shows in a formal way why the amplitude of the interference pattern is smaller in the case of deterministic absorption as implemented with the chopper. A fast chopper system has also been proposed for an experiment designed to discriminate between any ensemble interpretation and the nonergodic interpretation of quantum mechanics.¹⁹

As already mentioned in sec. II, with the absorbing lattice the labeling of the neutrons is due to the spectrum of transverse momenta created by the lattice. If some of the labeled neutrons are filtered out before reaching the O or the H detector then the relative number of neutrons unaffected by the lattice increases. One thus has less information about the path the neutron may have taken in the IFM. This is reflected by an increase of the amplitude of the interference pattern relative to the transmission probability of a neutron through the left beam. However, the absolute amplitude of the interference pattern is independent of what percentage of labeled neutrons are filtered out before reaching either the O or the H detector. It is also independent of whether the filtering is done before superposition of the

two beams or after it. It depends only on what one could call the stochastic component in deterministic absorption, which is the probability that a neutron incident on the lattice will neither be absorbed nor go to another momentum state, but remain in its original state. Interestingly the strength of this stochastic component is proportional to the square of the probability that the neutron passes the lattice (see the Appendix).

VI. CONCLUSION

In the experiments the effect of stochastic and deterministic absorption in one path of the neutron interferometer on the amplitude of the interference pattern was investigated, by means of absorbing foils for the one case and by means of beam choppers for the other. The difference predicted by quantum theory could be demonstrated and good quantitative agreement with the theory was reached. This proves wrong a picture of absorption in which a neutron is either absorbed and lost or passes through the absorber region unaffected. Furthermore, it was qualitatively shown with a one-dimensional absorbing lattice that those neutrons which carry the structural information of this deterministic absorber and thus indicate through which path they went inside the interferometer do not contribute to the interference pattern. They could be filtered out without a corresponding loss in the amplitude of the interference pattern.

ACKNOWLEDGMENTS

The authors would like to thank Professor D. M. Greenberger and Professor A. Zeilinger for useful and interesting discussions. The hospitality of the Institut Laue Langevin is gratefully acknowledged. This work was financially supported by Fonds zur Förderung der wissenschaftlichen Forschung (Project No. S4201), Wien, Austria.

APPENDIX: SUPERPOSITION OF A BEAM THROUGH AN ABSORBING LATTICE WITH AN UNDISTURBED BEAM

It will first be shown that a beam that goes through an absorbing lattice and is then superposed with an undisturbed beam gives an interference pattern whose amplitude is directly proportional to the transmission probability of a neutron through the lattice. It is sufficient to consider the problem in two dimensions. Let the lattice period be s , and the lattice be parallel to the y direction at $x = 0$. It shall have fully transparent sections of width l and completely absorbing sections of width $s - l$. The wave function $\psi_l(x, y)$ behind the lattice, which results from the incident plane wave whose wave vector \mathbf{k}_0 is parallel to the x direction can be written as

$$\psi_l(x, y) = \sum_{n=-n_{\max}}^{+n_{\max}} c_n e^{ik_x(n)x + ik_y(n)y} \quad (\text{A1})$$

with

$$k_y(n) = \frac{2\pi}{s} n \quad (\text{A2})$$

and

$$k_0 = [k_x^2(n) + k_y^2(n)]^{1/2}. \quad (\text{A3})$$

If $sk_0 \gg 2\pi$, that means the period of the lattice is much greater than the wavelength of the incident plane wave; then n_{\max} will be very large. In the experiments one had $sk_0/2\pi > 3.5 \times 10^5$. Using $n_{\max} = \infty$ the c_n can approximately be derived from the fact that directly at the lattice and along the y direction the wave function is periodic. It is either 0 or 1, if appropriately normalized. Thus with

$$\psi_l(x=0, y) \sim \sum_{n=-\infty}^{+\infty} c_n e^{i2\pi ny/s} \quad (\text{A4})$$

and with

$$a = \frac{l}{s} < 1 \quad (\text{A5})$$

one gets

$$c_n \sim \frac{\sin(n\pi a)}{n\pi}. \quad (\text{A6})$$

To see what interference one can get when one superposes $\psi_l(x, y)$ with an undisturbed plane wave $\psi_u(x) = \exp(ik_0 x)$ one has to average over one full period along the y direction. This is necessary as one assumes that the width of the detector is much larger than one period. For the intensity one then obtains

$$I(\phi) = \frac{1}{s} \int_{-s/2}^{s/2} |\psi_l(x, y) + \psi_u(x)e^{i\phi}|^2 dy. \quad (\text{A7})$$

ϕ denotes the relative phase caused by a phase shifter in between the two beams. The integration can readily be performed and one gets

$$I(\phi) = 1 + a + 2a \cos\phi. \quad (\text{A8})$$

The amplitude of the interference pattern is $2a$. Now the intensity of the neutrons through the lattice is (again averaged over one period)

$$I_l = \frac{1}{s} \int_{-s/2}^{s/2} |\psi_l(x, y)|^2 dy \approx \sum_{n=-\infty}^{+\infty} \frac{\sin^2(n\pi a)}{(n\pi)^2} = a. \quad (\text{A9})$$

Without the lattice this intensity would be equal to 1. Thus there exists a direct proportionality between the transmission probability of a neutron through the lattice and the amplitude of the interference pattern, just as in the case of deterministic absorption with the chopper [Eq. (9)]. In practice the beam incident on the IFM and then on the lattice is not a plane wave, of course. But one can perform the foregoing calculation for each plane-wave component of the beam separately. The final

result is practically the same, as long as the relative phase ϕ is the same for all components and the width of the beam is much greater than s . In the experiments the width of the beam was between $20s$ and $80s$.

Now it will be assumed that all those components of $\psi_l(x, y)$ will be filtered away whose wave vectors are different from that of the plane wave incident on the lattice. This means

$$\psi_l(x, y) \rightarrow \psi'_l(x) \quad (\text{A10})$$

and

$$\psi'_l(x) = c_0 e^{ik_0 x} = a e^{ik_0 x} \quad (\text{A11})$$

so that the intensity of neutrons that have gone along this beam is

$$I'_l = \frac{1}{s} \int_{-s/2}^{s/2} |\psi'_l(x)|^2 dy = a^2. \quad (\text{A12})$$

I'_l can be considered the stochastic component of the intensity behind the deterministic lattice absorber. It is equivalent to the square of the total intensity behind the lattice [Eq. (A9)]. The intensity due to the superposition with the undisturbed beam now becomes

$$\begin{aligned} I'(\phi) &= \frac{1}{s} \int_{-s/2}^{s/2} |\psi'_l(x) + \psi_u(x)e^{i\phi}|^2 dy \\ &= 1 + a^2 + 2a \cos\phi. \end{aligned} \quad (\text{A13})$$

The amplitude of the interference pattern is $2a$, which means that now it is proportional to the square root of the intensity along the beam through the lattice. This is the same as in the case of the stochastic foil absorbers [Eq. (8)]. From Eqs. (A8) and (A13) one notes that the amplitude of the interference pattern is the same independent of whether the neutrons with momenta different from that of the incident plane wave (labeled neutrons) are filtered out or not. But with respect to the transmission probability of a neutron along the path through the lattice it increases when the labeled neutrons are filtered out.

In the real IFM the filtering out of the neutrons is brought about by the two crystal plates following the absorbing lattice. However, since the labeled neutrons are filtered out only to a small degree, but are essentially just shifted from the H beam to the O beam, many arrive at the O detector but only few at the H detector. Still, there are some at the H detector. Therefore the amplitude of the interference pattern with respect to the transmission probability of a neutron along the path through the lattice to the H detector is greater than in the case of the chopper absorber, but smaller than in the case of the foil absorber.

¹Neutron Interferometry, edited by U. Bonse and H. Rauch (Clarendon, Oxford, 1979).

²S. A. Werner and A. G. Klein, in *Neutron Scattering*, Vol. 23A of *Methods of Experimental Physics*, edited by K. Sköld

and D. R. Price (Academic, New York, 1986), p. 259.

³D. M. Greenberger, *Rev. Mod. Phys.* **55**, 875 (1983).

⁴H. Rauch and J. Summhammer, *Phys. Lett.* **104A**, 44 (1984).

⁵M. L. Goldberger and F. Seitz, *Phys. Rev.* **71**, 294 (1947).

- ⁶H. Rauch, E. Seidl, D. Tuppinger, D. Petrascheck, and R. Scherm, *Z. Phys. B* (to be published).
- ⁷H. Kaiser, H. Rauch, G. Badurek, W. Bauspiess, and U. Bonse, *Z. Phys. A* **291**, 231 (1979).
- ⁸R. E. Word and S. A. Werner, *Phys. Rev. B* **26**, 4190 (1982).
- ⁹H. Rauch, U. Kischko, D. Petrascheck, and U. Bonse, *Z. Phys. B* **51**, 11 (1983).
- ¹⁰D. Petrascheck and H. Rauch, *Acta Cryst. A* **40**, 445 (1984).
- ¹¹H. Rauch and D. Petrascheck in *Neutron Diffraction*, Vol. 6 of *Topics in Current Physics*, edited by H. Dachs (Springer, Berlin, 1978), p. 303.
- ¹²U. Bonse, W. Graeff, *X-Ray Optics*, Vol. 22 of *Topics in Applied Physics*, edited by H.-T. Queisser (Springer, Berlin, 1977), p. 93.
- ¹³D. Petrascheck, *Phys. Rev. B* **35**, 6549 (1987).
- ¹⁴H. Rauch and D. Tuppinger, *Z. Phys. A* **322**, 427 (1985).
- ¹⁵H. Rauch, in *Neutron Interferometry*, edited by U. Bonse and H. Rauch (Clarendon, Oxford, 1979), p. 161.
- ¹⁶H. Kaiser, S. A. Werner, and E. A. George, *Phys. Rev. Lett.* **50**, 560 (1983).
- ¹⁷W. K. Wootters and W. H. Zurek, *Phys. Rev. D* **19**, 473 (1979).
- ¹⁸A. Zeilinger, *Physica* **137B**, 235 (1986).
- ¹⁹V. Buonomano, Universidade Estadual de Campinas Report, 1987 (unpublished).