





Constraints on Gaussian error channels and measurements for quantum communication

Alex Kwiatkowski ^{1,2} Ezad Shojaee,^{1,2} Sristy Agrawal,^{1,2} Akira Kyle ^{1,2} Curtis L. Rau ^{1,2}
Scott Glancy ¹ and Emanuel Knill^{1,3}

¹National Institute of Standards and Technology, Boulder, Colorado 80305, USA

²Department of Physics, University of Colorado, Boulder, Colorado 80309, USA

³Center for Theory of Quantum Matter, University of Colorado, Boulder, Colorado 80309, USA



(Received 2 October 2022; revised 13 March 2023; accepted 15 March 2023; published 10 April 2023)

Joint Gaussian measurements of two quantum systems are important for quantum communication between remote parties and are often used in continuous-variable teleportation or entanglement-swapping protocols. Many of the errors in real-world implementations can be modeled by independent Gaussian error channels acting prior to measurement. In this work we study independent single-mode Gaussian error channels on two modes **A** and **B** that take place prior to a joint Gaussian measurement. We determine the set of pairs of such channels that render all Gaussian measurements separable and therefore unsuitable for entanglement swapping or teleportation of arbitrary input states. For example, if the error channels are loss with parameters l_A and l_B followed by added noise with parameters n_A and n_B , then all Gaussian measurements are separable if and only if $l_A + l_B + n_A + n_B \geq 1$.

DOI: [10.1103/PhysRevA.107.042604](https://doi.org/10.1103/PhysRevA.107.042604)

I. INTRODUCTION

Quantum communication between remote parties is a key requirement in the establishment of a quantum network [1]. One important tool for quantum communication is a joint measurement of two parties, as in teleportation or entanglement swapping [2–5]. Photonic modes are typically the easiest quantum systems to directly transmit between remote parties, and this motivates a joint measurement of two bosonic systems [6–8] as a natural choice for quantum communication. Although both Gaussian [9–12] and non-Gaussian [13,14] joint measurements have been studied in this context and realized experimentally [15–20], high-efficiency Gaussian measurements are more readily available. Furthermore, many types of physical error sources throughout a protocol can be modeled by independent Gaussian error channels acting prior to measurement [21–24]. The combination of an ideal Gaussian measurement with Gaussian error channels results in an effective total measurement that is also Gaussian [25]. If this effective Gaussian measurement is separable, meaning that the positive-operator-valued measure (POVM) elements of the measurement are all convex combinations of positive product operators, then it is unsuitable for teleportation or entanglement swapping regardless of the input states.

In this work we investigate independent pairs of single-mode Gaussian error channels on modes **A** and **B** acting prior to a joint Gaussian measurement of **AB**. We determine the set of pairs of such channels that render all effective Gaussian measurements separable. We achieve this by first analyzing the case of amplification channels with the parameters a_A and a_B followed by loss channels with the parameters l_A and l_B . In this case we prove that all effective Gaussian measurements are separable if and only if $l_A + l_B \geq 1$, regardless of the amplification parameters. We refer to this inequality as the loss condition for separability. Although applying an

entanglement-breaking Gaussian channel [26] prior to measurement immediately implies that the effective measurement is separable, we note that the loss condition for separability does not follow from analysis of entanglement-breaking Gaussian channels. For example, loss channels with the loss parameter $0 \leq l < 1$ are not entanglement breaking. In this paper we provide a direct and self-contained proof of the loss condition for separability. We note that it can also be obtained by applying the results of Refs. [27,28] to dual Gaussian channels and we elaborate on this point in Sec. VI. For related prior work we also refer to Refs. [29,30].

We then use the classification of single-mode Gaussian channels in Ref. [21] to reduce all non-entanglement-breaking pairs of single-mode Gaussian channels to the loss condition for separability. For example, if the channels consist of losses l_A and l_B followed by added noises n_A and n_B , then all effective Gaussian measurements are separable if and only if $l_A + l_B + n_A + n_B \geq 1$. In contrast, joint photon number measurements, which are non-Gaussian, can remain inseparable when large loss channels act prior to measurement. For example, in the protocol of Duan *et al.* [31] the probability of successfully swapping entanglement with a joint photon number measurement remains nonzero even when arbitrary loss $0 \leq l < 1$ is applied to the two modes prior to measurement.

Experimentally, joint Gaussian measurements can be realized optically with high efficiency and low noise, meaning $l_A + l_B + n_A + n_B \leq 1$ when errors like detection inefficiency, electronic noise, and loss from mode matching to local oscillators are all combined and parametrized as loss followed by noise. For example, Ref. [20] reports a total loss of roughly $l = 0.1$ on the measured half of an entangled resource state in an experiment that performs hybrid teleportation with a joint Gaussian measurement. Similarly, Ref. [18] reports a loss of roughly $l = 0.1$ on each of the two measured modes in an all-Gaussian entanglement swapping experiment.

However, we emphasize that all Gaussian error sources, including, for example, noisy resource states, mode-matching loss, or transmission loss, that act prior to measurement must also be included when the inequality $l_A + l_B + n_A + n_B \leq 1$ is evaluated. As a result, there can be situations where the total combination of all Gaussian errors that act prior to measurement is sufficiently destructive to prevent even a perfect joint Gaussian measurement from being used for teleportation or entanglement swapping. As one example, consider a protocol to generate entanglement between two distant microwave modes by first creating optical-microwave entangled resource states at the distant nodes, transmitting the optical modes to a central node, and then performing entanglement swapping on the optical modes. Creation of the optical-microwave resource states requires some form of transduction or related processes, such as those discussed in Ref. [32]. Some transduction processes considered in Ref. [32] can be modeled, for realistic device parameters, as creating a pure state followed by loss of $l = 0.5$ or more on the optical side. In this case, a perfect joint optical Gaussian measurement cannot be used for entanglement swapping, even when all transmission losses are neglected.

In the microwave domain, single-mode quadrature measurements with effective losses of roughly $l = 0.38$ and 0.31 have been reported in Refs. [33,34], respectively. These effective loss parameters are obtained by modeling the imperfect measurement as a loss channel followed by a perfect quadrature measurement. An equivalent model is a noise channel followed by a perfect quadrature measurement, in which case the noise parameters are $n = 1/(2 - 2l) - \frac{1}{2} = 0.31$ and $n = 0.22$, respectively [33,34]. This indicates that the requirement $l_A + l_B + n_A + n_B \leq 1$ may be especially relevant to joint microwave Gaussian measurements when all additional sources of loss and noise are considered.

Our results also provide a more general context for some of the results of Refs. [9,11,16,35–43], which study teleportation or entanglement swapping with specific Gaussian measurements on specific input states in the presence of Gaussian error channels.

This paper is organized as follows. In Sec. II we provide preliminaries about Gaussian states, measurements, and channels. In Sec. III we prove Proposition 2, which directly establishes the loss condition for separability in the special case that the amplification parameters are zero. In Sec. IV we establish the loss condition for separability for arbitrary amplification parameters in Proposition 3 and obtain the corresponding condition when the channels are loss followed by noise in Proposition 5. In Sec. V we provide a method of determining, for any pair of single-mode Gaussian error channels that act prior to measurement, whether or not all effective Gaussian measurements are separable. In Sec. VI we show how the loss condition for separability can be obtained by applying the dual error channels to the POVM elements of a Gaussian measurement.

II. PRELIMINARIES

In this paper we assume familiarity with continuous-variable quantum mechanics and Gaussian quantum information as described, for example, in the review article in Ref. [6].

We also assume a basic understanding of Gaussian channels as described in Ref. [21].

A bosonic system of m modes is characterized by m creation and annihilation operators $\{\hat{a}_i, \hat{a}_i^\dagger\}_{i=1}^m$ with commutation relations $[\hat{a}_i, \hat{a}_j] = 0$ and $[\hat{a}_i, \hat{a}_j^\dagger] = \delta_{ij}$. We work with quadrature operators $\hat{x}_i = (\hat{a}_i + \hat{a}_i^\dagger)/\sqrt{2}$ and $\hat{p}_i = i(\hat{a}_i^\dagger - \hat{a}_i)/\sqrt{2}$ with commutation relations $[\hat{x}_i, \hat{p}_j] = i\delta_{ij}$. We label individual modes as A, B, C, D, E, and F and the annihilation operators corresponding to those modes are denoted by $\hat{a}, \hat{b}, \hat{c}, \hat{d}, \hat{e},$ and \hat{f} , respectively. We also occasionally use A and B to refer to multimode systems, in which case the annihilation operators are denoted by \hat{a}_i or \hat{b}_i , where i is the mode index.

The single-mode Gaussian channels that are especially relevant are loss, amplification, and added noise, which are referred to in Ref. [28] as types \mathcal{C}_1 , \mathcal{C}_2 , and \mathcal{B}_2 , respectively, and are phase insensitive. We choose the conventions that the covariance matrix of vacuum is $\mathbb{1}/2$, a loss channel with the parameter $0 \leq l \leq 1$ transforms covariance matrices V according to $V \mapsto (1 - l)V + l \cdot \mathbb{1}/2$, an amplification channel with the parameter $a > 1$ acts according to $V \mapsto aV + (a - 1) \cdot \mathbb{1}/2$, and a noise channel with the parameter n acts according to $V \mapsto V + n \cdot \mathbb{1}$. A particular family of single-mode channels that we study in this paper is realized by amplification with the parameter a followed by loss with the parameter l , which transforms covariance matrices V according to

$$V \mapsto a(1 - l)V + [a(1 - l) + 2l - 1] \frac{\mathbb{1}}{2}. \quad (2.1)$$

We emphasize that a Gaussian channel is uniquely defined, up to displacement, by its action on covariance matrices. Some Gaussian channels are entanglement breaking, meaning that for any input state the output system is unentangled from every other system. We refer to Ref. [26] for further information about entanglement-breaking Gaussian channels.

Following Refs. [25,44], we adopt the definition of a noiseless Gaussian measurement on a system A of m modes to be any measurement consisting of an arbitrary Gaussian unitary followed by homodyne measurements on k modes and heterodyne measurements on the remaining $m - k$ modes. We use the definitions of homodyne and heterodyne measurement in Ref. [25] and we summarize them here. A homodyne measurement is a von Neumann measurement of a quadrature \hat{x} with a POVM that is the spectral measure of the operator \hat{x} and has the associated resolution of the identity conventionally written as $\text{id} = \int dx |x\rangle\langle x|$. A heterodyne measurement is defined by the POVM given by the resolution of the identity $\text{id} = \frac{1}{\pi} \int_{\mathbb{C}} d\alpha |\alpha\rangle\langle\alpha|$, where $|\alpha\rangle\langle\alpha|$ is the projector onto the coherent state labeled by α [7]. We refer to the improper projectors $|x\rangle\langle x|$ and the projectors $|\alpha\rangle\langle\alpha|$ as the POVM elements of the homodyne and the heterodyne measurements, respectively. We use the notation $|x = 0\rangle$ to denote the improper 0 eigenstate of the operator \hat{x} and $|0\rangle$ to denote vacuum, which is the 0 eigenstate of the operator \hat{a} . The results of Ref. [25] imply that a noiseless Gaussian measurement of a joint system AB where system B is initialized in a pure Gaussian state is equivalent to a noiseless Gaussian measurement of system A alone. It follows that our results for arbitrary Gaussian measurements hold even when Gaussian ancillas are permitted. Furthermore, Ref. [25] implies that a noiseless Gaussian measurement of a

system of m modes can be characterized by a family $\{M_i\}_{i=1}^m$ of linear combinations of creation and annihilation operators with the properties in the following list:

- (i) $\{M_i\}_{i=1}^m$ are mutually commuting,
- (ii) $\{M_i\}_{i=1}^m$ are linearly independent,
- (iii) $M_i = M_i^\dagger$ for $i = 1, \dots, k$, for some integer k ,
- (iv) $[M_j, M_{j'}^\dagger] = \delta_{jj'}$ for $k+1 \leq j, j' \leq m$. (2.2)

Thus, the first k operators behave like quadrature operators and the last $m-k$ behave like annihilation operators. We note that k can be 0, in which case all of the operators $\{M_i\}_{i=1}^m$ satisfy property (iv) and none of them satisfy property (iii). If the operators $\{M_i\}_{i=1}^m$ satisfy the properties in the list (2.2), then they can be mapped to the operators $\hat{x}_1, \dots, \hat{x}_k, \hat{a}_{k+1}, \dots, \hat{a}_m$ by a Gaussian unitary U . This follows from the fact that the m operators $\{M_1, \dots, M_k, (M_{k+1} + M_{k+1}^\dagger)/\sqrt{2}, \dots, (M_m + M_m^\dagger)/\sqrt{2}\}$ and the $m-k$ operators $\{i(M_{k+1}^\dagger - M_{k+1})/\sqrt{2}, \dots, i(M_m^\dagger - M_m)/\sqrt{2}\}$ satisfy the same commutation relations as the quadrature operators $\{\hat{x}_1, \dots, \hat{x}_m\}$ and $\{\hat{p}_{k+1}, \dots, \hat{p}_m\}$, respectively, and by Ref. [45] they can be extended to a symplectic basis, which is defined as a basis that is related to the original quadrature operators by a symplectic transform that corresponds to a Gaussian unitary U . As a result, the state $|\psi\rangle := U(|\hat{x} = 0\rangle_1 \otimes \dots \otimes |\hat{x} = 0\rangle_k \otimes |0\rangle_{k+1} \otimes \dots \otimes |0\rangle_m)$ is annihilated by all the $\{M_i\}_{i=1}^m$, meaning $M_i |\psi\rangle = 0$ for all i . If an arbitrary multimode displacement α is applied, the state $\mathcal{D}(\alpha)|\psi\rangle$ is also a simultaneous eigenstate of the $\{M_i\}_{i=1}^m$ with eigenvalues determined by the displacement. In this paper, when we say that a Gaussian measurement is characterized by $\{M_i\}_{i=1}^m$, we mean that the M_i satisfy the properties in the list (2.2) and that the POVM elements of the measurement consist of the joint eigenstates of $\{M_i\}_{i=1}^m$, which are of the form $\mathcal{D}(\alpha)|\psi\rangle\langle\psi|\mathcal{D}^\dagger(\alpha)$ for all possible displacements α . An important property of operators M in the span of $\{M_i\}$ is that they have non-negative commutators with their adjoints, that is, $[M, M^\dagger] \geq 0$. Furthermore, any operator M satisfying $[M, M^\dagger] \geq 0$ can be extended to a list of operators $\{M_i\}_{i=1}^m$ that characterize a Gaussian measurement such that M is in the span of the $\{M_i\}_{i=1}^m$. This can be verified in the case that $[M, M^\dagger] = 0$ by first observing that $M + M^\dagger$ and $iM^\dagger - iM$ are commuting self-adjoint operators so their span, which contains M , admits a basis of commuting self-adjoint operators. This basis can be extended to a symplectic basis and in particular can be extended to a list of m linearly independent mutually commuting self-adjoint operators [45]. Similarly, if $[M, M^\dagger] > 0$ then it can be rescaled so that $[M, M^\dagger] = 1$ and the operators $\{(M + M^\dagger)/\sqrt{2}, i(M^\dagger - M)/\sqrt{2}\}$ then satisfy the commutation relations of \hat{x}_m and \hat{p}_m . These can be extended to a symplectic basis $\{\hat{x}_1, \dots, \hat{x}_m, \hat{p}_1, \dots, \hat{p}_m\}$, and the list of operators $\{\hat{x}_1, \dots, \hat{x}_{m-1}, M\}$ then satisfies the properties in the list (2.2) for $k = m - 1$.

As part of our methods of proof we analyze Gaussian measurements on a system AC when the subsystem C is initialized in vacuum. If $|\psi\rangle\langle\psi|_{AC}$ is a POVM element of the full AC measurement, then the effective POVM element on

system A is

$$\Pi_A = \text{tr}_C[\text{id}_A \otimes |0\rangle\langle 0|_C |\psi\rangle\langle\psi|_{AC}]. \quad (2.3)$$

The right-hand side is mathematically equivalent to the calculation of the state on A after the system AC is initialized in the Gaussian state $|\psi\rangle\langle\psi|_{AC}$ and then system C is projected into vacuum $|0\rangle\langle 0|_C$. In such a situation, the resulting state on system A is a Gaussian pure state, which implies that the effective POVM element Π_A is a projector (possibly improper) onto a pure Gaussian state on system A.

When error channels are applied before a joint measurement the effective measurement may be separable. We use the definition that a Gaussian measurement is separable if it has POVM elements that are all convex combinations of positive product operators. If a measurement is separable according to this definition then it cannot be used to generate entanglement during entanglement swapping or to teleport a state such that entanglement with another system is preserved. For completeness we elaborate on this point in Appendix B.

In this paper the Gaussian measurements that we directly prove are separable can be expressed by circuits of the form shown on the left-hand side of the diagram (2.4), which shows a Gaussian unitary U_G acting on two modes A and B and two vacuum ancilla modes E and F, followed by a noiseless Gaussian measurement G of A and B and loss of the modes E and F that is mathematically represented by a partial trace:

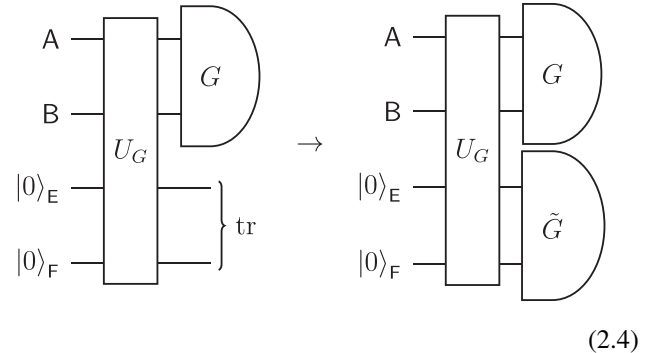

To obtain a sufficient condition for the separability of certain Gaussian measurements of this form, we introduce a hypothetical Gaussian measurement \tilde{G} on modes E and F, as shown on the right-hand side of the diagram (2.4). The original measurement on the left-hand side is equivalent to the measurement shown on the right side followed by loss of the outcome of the measurement \tilde{G} . The measurement on the right-hand side can be interpreted as a noiseless Gaussian measurement of the full system of A, B, E, and F where the modes E and F are initialized in vacuum. This measurement is equivalent to some Gaussian measurement of just the modes A and B and we refer to its POVM elements as the effective system AB POVM elements. If the effective system AB POVM elements are all product operators then the original measurement on the left-hand side of the diagram (2.4) must have POVM elements that are all separable. This follows because the effective system AB POVM elements of the measurement on the left-hand side must be convex combinations of the system AB POVM elements of the measurement on the right, where the convex combinations result from the loss of the outcome of the measurement \tilde{G} .

III. LOSS CONDITION FOR SEPARABILITY

In this section we establish that the effective measurement shown in the circuit

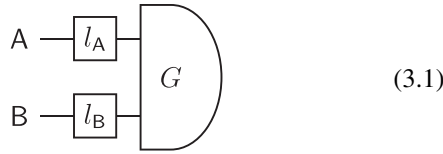

is separable for all Gaussian measurements G when the loss-channel parameters l_A and l_B satisfy

$$l_A + l_B \geq 1. \quad (3.2)$$

The separability condition (3.2) is proven in Proposition 2. The overall strategy is to first dilate the loss channels by applying beam splitters with two vacuum ancilla modes E and F [21,28], as on the left-hand side of the diagram

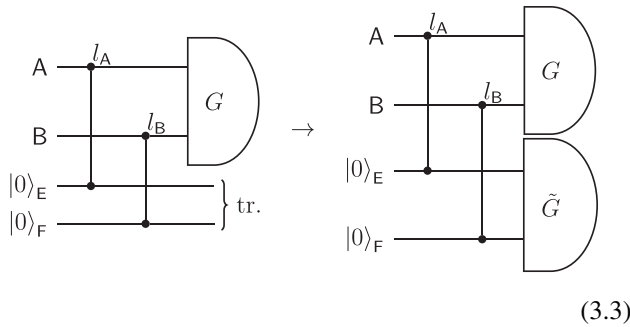

Here vertical lines connecting two horizontal mode lines indicate beam splitters. The beam-splitter labels indicate the beam-splitter reflectivity for the labeled mode, which is equal to the loss parameter. Then consider replacing the trace on the two ancilla modes E and F by a Gaussian measurement \tilde{G} to be determined, as on the right-hand side of the diagram (3.3). We show that whenever $l_A + l_B \geq 1$, for all Gaussian measurements G there exists a corresponding Gaussian measurement \tilde{G} for which the effective system AB POVM elements of the combined G and \tilde{G} measurement are all product operators. As discussed after the diagram (2.4), it follows in this case that the effective measurement on the left-hand side of the diagram (3.3) is separable. To this end, we first give an algebraic sufficient condition for noiseless Gaussian measurements with vacuum ancillas to have POVM elements that are all product operators.

Proposition 1. Let A, B, E, and F be one-mode bosonic systems where modes E and F are prepared in vacuum. Consider a noiseless Gaussian measurement G of ABEF characterized by four operators $\{M_1, M_2, M_3, M_4\}$ as described after the list (2.2). If there exists a complex linear combination of the $\{M_i\}$ of the form

$$\hat{M} = \hat{A} + \xi \hat{e}^\dagger + \zeta \hat{f}^\dagger, \quad (3.4)$$

with \hat{A} a nonzero linear combination of $\{\hat{a}, \hat{a}^\dagger\}$ on system A and ξ and ζ arbitrary complex coefficients, then the effective measurement on system AB has POVM elements that are all projectors onto pure product Gaussian states.

Proof. Let $|\phi\rangle_{ABEF}$ be a simultaneous eigenstate of the M_i . The displacements of $|\phi\rangle_{ABEF}$ are also simultaneous eigenstates and there is a displacement for which the eigenvalue

of \hat{M} is not zero. Without loss of generality, assume that $\hat{M}|\phi\rangle = \lambda|\phi\rangle$ with $\lambda \neq 0$. By rescaling \hat{M} we can assume that $\lambda = 1$. According to Eq. (2.3), the effective system AB POVM elements of the measurement G can be expressed as

$$\Pi_{AB} = \text{tr}_{EF}(\text{id}_{AB} \otimes |0\rangle\langle 0|_{EF} |\phi\rangle\langle \phi|_{ABEF}) \quad (3.5)$$

or are related to Π_{AB} by displacements. Insert \hat{M} in the partial trace to obtain

$$\Pi_{AB} = \text{tr}_{EF}(\text{id}_{AB} \otimes |0\rangle\langle 0|_{EF} \hat{M} |\phi\rangle\langle \phi|_{ABEF}). \quad (3.6)$$

The creation operators \hat{e}^\dagger and \hat{f}^\dagger annihilate vacuum from the right, so this simplifies to

$$\Pi_{AB} = \text{tr}_{EF}(\text{id}_{AB} \otimes |0\rangle\langle 0|_{EF} \hat{A} |\phi\rangle\langle \phi|_{ABEF}) = \hat{A} \Pi_{AB}. \quad (3.7)$$

By taking adjoints on both sides, we also have $\Pi_{AB} = \Pi_{AB} \hat{A}^\dagger$. By construction there is a one-mode Gaussian measurement that is characterized by \hat{A} and the 1 eigenstate $|\varphi\rangle_A$ of \hat{A} is unique. Intuitively, because $\hat{A} - \text{id}_A$ annihilates Π_{AB} on the left and $\hat{A}^\dagger - \text{id}_A$ annihilates it on the right, Π_{AB} must be of the form $\Pi_B \otimes |\varphi\rangle\langle \varphi|_A$. To verify this statement, let $\{|k\rangle_B\}_{k=0}^\infty$ be an orthonormal basis of B, for example, the number state basis. Then $\text{id}_B = \sum_k |k\rangle\langle k|_B$ and we can express

$$\begin{aligned} \Pi_{AB} &= \sum_k |k\rangle\langle k|_B \Pi_{AB} \sum_{k'} |k'\rangle\langle k'|_B \\ &= \sum_{k,k'} |k\rangle\langle k|_B \langle k'|_B \Pi_{AB} |k'\rangle_B. \end{aligned} \quad (3.8)$$

The operators $\Pi_{k,k'} := \langle k|_B \Pi_{AB} |k'\rangle_B$ on A are annihilated on the left by $\hat{A} - 1$ and on the right by $\hat{A}^\dagger - 1$. They are therefore proportional to $|\varphi\rangle\langle \varphi|_A$. Substituting accordingly on the right-hand side of Eq. (3.8) expresses Π_{AB} as a tensor product of a projector acting on B with a projector onto a pure Gaussian state acting on A. Since Π_{AB} is a pure Gaussian state, the projector acting on B is also pure Gaussian. Because all POVM elements of a Gaussian measurement are related by displacements, it follows that all effective system AB POVM elements of the measurement G are product operators. ■

Proposition 2. Let G be a Gaussian measurement of modes AB. Consider the effective Gaussian measurement described in the circuit

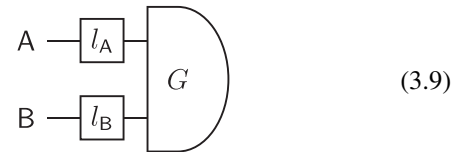

If the loss channel parameters l_A and l_B satisfy $l_A + l_B \geq 1$, then this effective Gaussian measurement is separable.

Proof. If the proposition holds for all noiseless Gaussian measurements, then it holds for all, potentially noisy, Gaussian measurements. We therefore restrict G to be a noiseless Gaussian measurement for the remainder of the proof.

We first dilate the loss in the circuit of the proposition to obtain the circuit shown on the left-hand side of the diagram (3.3) and then determine a measurement \tilde{G} as on the right-hand side of the diagram to prove separability. We write $\tilde{a}, \tilde{b}, \tilde{e}$, and \tilde{f} for the Heisenberg-evolved mode operators after the unitary implementing the dilated loss. In terms of the original

mode operators, we have

$$\begin{aligned}\tilde{a} &= \sqrt{1-l_A}\hat{a} + \sqrt{l_A}\hat{e}, \\ \tilde{e} &= \sqrt{1-l_A}\hat{e} - \sqrt{l_A}\hat{a}, \\ \tilde{b} &= \sqrt{1-l_B}\hat{b} + \sqrt{l_B}\hat{f}, \\ \tilde{f} &= \sqrt{1-l_B}\hat{f} - \sqrt{l_B}\hat{b}.\end{aligned}\quad (3.10)$$

If either $l_A = 1$ or $l_B = 1$, then one of the modes is replaced by vacuum before the measurement, which implies separability of the effective measurement. For the remainder of the proof, we assume that neither equality holds.

Choose M_1 and M_2 acting on modes **AB** so that they characterize G , as described after the list (2.2). The operators M_i are independent commuting linear combinations of the four operators \tilde{a} , \tilde{b} , \tilde{a}^\dagger , and \tilde{b}^\dagger . By independence, there is a nonzero linear combination M of the M_i that is in the three-dimensional span of \tilde{a} , \tilde{a}^\dagger , and \tilde{b}^\dagger . Write $M = \alpha\tilde{a} + \alpha'\tilde{a}^\dagger + \beta'\tilde{b}^\dagger$ for complex coefficients α , α' , and β' . In terms of the incoming mode operators,

$$\begin{aligned}M &= \alpha(\sqrt{1-l_A}\hat{a} + \sqrt{l_A}\hat{e}) + \alpha'(\sqrt{1-l_A}\hat{a}^\dagger + \sqrt{l_A}\hat{e}^\dagger) \\ &\quad + \beta'(\sqrt{1-l_B}\hat{b}^\dagger + \sqrt{l_B}\hat{f}^\dagger).\end{aligned}\quad (3.11)$$

We wish to apply Proposition 1, which requires eliminating the terms of M involving \hat{e} and \hat{b}^\dagger without introducing terms involving \hat{b} or \hat{f} . Suppose the Gaussian measurement \tilde{G} is applied to modes **EF** and suppose \tilde{M} is one of a pair of operators that characterize \tilde{G} . Then $M + \tilde{M}$ is a linear combination of the operators that characterize the full measurement on **ABEF** and it can be used with Proposition 1. With foresight, let $\tilde{M} := \gamma\tilde{e} + \delta\tilde{f}^\dagger$ with $\gamma = -\alpha\sqrt{l_A}/\sqrt{1-l_A}$ and $\delta = \beta'\sqrt{1-l_B}/\sqrt{l_B}$. The coefficient γ of \tilde{e} is chosen to cancel the term involving \hat{e} in M and the coefficient δ of \tilde{f}^\dagger is chosen to cancel the term involving \hat{b}^\dagger . By design, no unwanted terms are introduced. If this assignment of \tilde{M} is possible then $M + \tilde{M}$ can be expressed as $M + \tilde{M} = A + \xi\hat{e}^\dagger + \zeta\hat{f}^\dagger$ for some complex ξ and ζ with A acting on mode **A**, in which case Proposition 1 implies that the full measurement is separable across **A** and **B**. We next show that if $l_A + l_B \geq 1$, then there exists a Gaussian measurement \tilde{G} such that $\tilde{M} := \gamma\tilde{e} + \delta\tilde{f}^\dagger$ is one of a pair that characterize \tilde{G} . In fact, as discussed after the list (2.2), it suffices for \tilde{M} to satisfy $[\tilde{M}, \tilde{M}^\dagger] = |\gamma|^2 - |\delta|^2 \geq 0$. In terms of the loss parameters, this condition is expressed as

$$|\alpha|^2 \left(\frac{l_A}{1-l_A} \right) - |\beta'|^2 \left(\frac{1-l_B}{l_B} \right) \geq 0. \quad (3.12)$$

As noted in Sec. II, because M is an operator in the span of a family characterizing a Gaussian measurement, we have $[M, M^\dagger] \geq 0$. In terms of the coefficients in the expression for M , this becomes $|\alpha|^2 - |\alpha'|^2 - |\beta'|^2 \geq 0$. In particular, the inequality $|\alpha|^2 \geq |\beta'|^2$ is satisfied. Thus Eq. (3.12) is satisfied if $l_A/(1-l_A) \geq (1-l_B)/l_B$. Multiplying out the non-negative denominators gives the inequality $l_A l_B \geq (1-l_A)(1-l_B)$, which can be rewritten as $l_A + l_B \geq 1$. ■

IV. PAIRS OF PHASE-INSENSITIVE SINGLE-MODE CHANNELS

We now use Proposition 2 to determine conditions for separability of all Gaussian measurements when other phase-insensitive single-mode Gaussian error channels are applied prior to measurement. We find it convenient to begin with channels that take the form of amplification followed by loss.

Proposition 3. Let G be a Gaussian measurement of modes **AB**, let a_A and a_B be parameters of amplification channels, and let l_A and l_B be parameters of loss channels. The effective measurement shown in the diagram

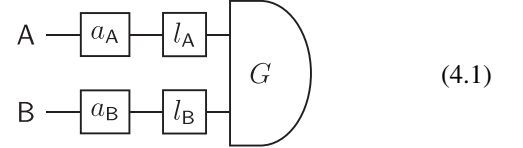

is separable for all G if and only if $l_A + l_B \geq 1$.

Proof. If $l_A + l_B \geq 1$, then Proposition 2 applies and the effective measurement is separable regardless of the amplification parameters a_A and a_B . If $l_A + l_B < 1$, then simulating an all-Gaussian entanglement swapping scenario with a continuous-variable (CV) Bell measurement, similar to the one in Ref. [35], and checking for entanglement [46,47] of the two output modes demonstrates that entanglement swapping is possible regardless of the values of a_A and a_B . This calculation is described in further detail in Proposition 9. As a result, the CV Bell measurement cannot be separable if $l_A + l_B < 1$, so the inequality in Proposition 2 is tight even when arbitrary amplification channels act prior to loss. ■

We next address the problem of establishing a condition for separability when the error channels take the form of losses l_A and l_B followed by added noise with the parameters n_A and n_B . We obtain this condition, given in Proposition 5, by reparametrizing the channels as amplification followed by loss and applying Proposition 3. The relationship between the two parametrizations is given by Proposition 4.

Proposition 4. A non-entanglement-breaking Gaussian error channel that consists of loss l followed by added noise n is equivalent to a channel that consists of amplification with the parameter $a' = \frac{1-l}{1-l-n}$ followed by a loss channel with the parameter $l' = l + n$ as shown in the diagram

$$\rho \text{ --- } [l] \text{ --- } [n] \text{ --- } = \rho \text{ --- } [a'] \text{ --- } [l'] \text{ --- } \quad (4.2)$$

Proof. By applying the definitions in Sec. II, loss with the parameter l followed by noise with the parameter n acts on covariance matrices V according to

$$V \mapsto (1-l)V + \left(\frac{l}{2} + n \right) \mathbb{1}. \quad (4.3)$$

This can be matched to Eq. (2.1) to recover the effective amplification and loss parameters a' and l' . Matching terms proportional to V requires $(1-l')a' = (1-l)$ and then matching the constant terms and solving for l' gives $l' = l + n$. The denominator of a' is positive as long as $l + n < 1$, which is equivalent to requiring that the channel is not entanglement breaking [26]. ■

Proposition 5. Let G be a Gaussian measurement of modes AB , let l_A and l_B be parameters of loss channels, and let n_A and n_B be parameters of noise channels. The effective measurement shown in the diagram

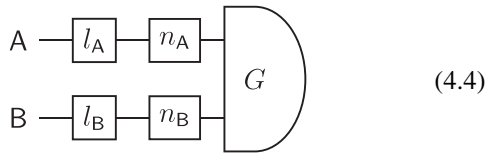

is separable for all G if and only if $l_A + l_B + n_A + n_B \geq 1$.

Proof. By Proposition 4, this is equivalent to the circuit

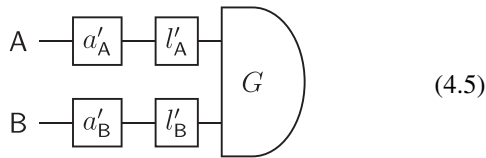

for loss parameters $l'_A = l_A + n_A$ and $l'_B = l_B + n_B$ and amplification parameters a'_A and a'_B . Applying Proposition 3 immediately gives the condition for separability $l_A + l_B + n_A + n_B \geq 1$. ■

V. ALL PAIRS OF SINGLE-MODE GAUSSIAN CHANNELS

We now show that Proposition 3, which covers error channels that are amplification followed by loss, can be extended to cover all pairs of single-mode Gaussian error channels. To summarize the result, for any pair of single-mode Gaussian channels, the following procedure can be used to determine whether all effective Gaussian measurements are separable. First, check if either channel in the pair is entanglement breaking, which would immediately imply that the effective measurement is separable. Then, if any channel is unitarily equivalent to a channel that adds noise to a single quadrature, treat it as the identity channel in what follows. Finally, reparametrize the remaining channel(s), up to unitary equivalence, as amplification followed by loss and apply Proposition 3. Unitary equivalence of two channels means that one can be transformed into the other by applying single-mode Gaussian unitaries before and after. We emphasize that reparametrization up to unitary equivalence is suitable for our purpose because any single-mode unitaries after the channels can be absorbed into a general Gaussian measurement and any single-mode unitaries before the channels can be absorbed into state preparation. In either case this will not affect the determination of whether or not all effective Gaussian measurements are separable.

We now prove that this procedure works for all pairs of single-mode Gaussian channels. In particular, we prove in Proposition 6 that a non-entanglement-breaking single-mode Gaussian channel can be reparametrized as amplification followed by loss, unless it is unitarily equivalent to a channel that adds noise to a single quadrature. We then show that a channel that adds noise to a single quadrature can be treated as an identity, meaning $l = a = 0$, when the inequality in Proposition 3 is evaluated. Intuitively, this follows because a squeezing unitary can be applied before and after the channel in order

to make the amount of noise added to a single quadrature arbitrarily small.

Proposition 6. All non-entanglement-breaking single-mode Gaussian channels are unitarily equivalent to amplification followed by loss or unitarily equivalent to a channel that adds noise to only one quadrature.

Proof. Single-mode Gaussian channels have been classified up to unitary equivalence in Ref. [21]. We use the notation from Refs. [21,26,28], which define four families of single-mode Gaussian channels denoted by A , B , C , and D and prove that any single-mode Gaussian channel is a member of one of these families. Channels of type A represent complete loss of one or both quadratures and are entanglement breaking [6,26]. Channels of type D are the complements of amplification channels and are also entanglement breaking [26]. Types B and C are further subdivided into B_1 , B_2 , C_1 , and C_2 in Refs. [26,28]. The channel B_1 adds a constant amount of noise to a single quadrature. Matching the definitions in Ref. [28] to the definitions in Sec. II shows that channels of type B_2 are noise channels with the parameter n , channels of type C_1 can be parametrized as loss l followed by added noise n_l , and channels of type C_2 can be parametrized as amplification a followed by added noise n_a . These channels may or may not be entanglement breaking depending on the specific values of the parameters. We showed that non-entanglement-breaking channels of type C_1 can be reparametrized as amplification followed by loss in Proposition 4 and we show it for channels of type B_2 in Lemma 1 and for channels of type C_2 in Lemma 2.

Lemma 1. A non-entanglement-breaking noise channel with the parameter n can be parametrized as amplification with the parameter $a' = \frac{1}{1-n}$ followed by loss with the parameter $l' = n$.

Proof. A noise channel with the parameter n has the action on a covariance matrix V of $V \mapsto V + n \cdot \mathbb{1}$ and is entanglement breaking if and only if $n \geq 1$ [26]. If $n < 1$, then matching to the action of amplification a' followed by loss l' in Eq. (2.1) shows that $a' = \frac{1}{1-n}$ and $l' = n$. ■

Lemma 2. A non-entanglement-breaking Gaussian error channel that consists of amplification a followed by added noise n is equivalent to an amplification channel followed by a loss channel with parameters $a' = \frac{a}{1-n}$ and $l' = n$, respectively. This equivalence is shown in the diagram

$$\rho \text{ --- } \boxed{a} \text{ --- } \boxed{n} \text{ --- } = \rho \text{ --- } \boxed{a'} \text{ --- } \boxed{l'} \text{ --- } \tag{5.1}$$

Proof. A channel that consists of amplification with the parameter a followed by noise with the parameter n is entanglement breaking if and only if $n \geq 1$ [26]. If $n < 1$, then applying the definitions in Sec. II shows that the channel acts on covariance matrices V as

$$V \mapsto aV + (a - 1)/2\mathbb{1} + n\mathbb{1}. \tag{5.2}$$

Matching this to the action of amplification a' followed by loss l' in Eq. (2.1) shows that $a' = a/(1 - n)$ and $l' = n$. ■

As a result, all pairs of non-entanglement-breaking single-mode channels of types B_2 , C_1 , and C_2 can be reparametrized as amplification followed by loss and are covered by Proposition 3. The only remaining non-entanglement-breaking

channels are of type B_1 and add noise to a single quadrature. This completes the proof of Proposition 6. ■

To address channels of type B_1 , which add noise to a single quadrature, we first observe that the amount of added noise can be made arbitrarily small by antisqueezing that quadrature before the channel and squeezing it afterward. As a result, these channels are arbitrarily close to the identity channel by unitary equivalence and can be treated as such when combined with another channel on the second system for the purpose of checking whether a pair of error channels makes all effective Gaussian measurements separable. To make this claim precise, consider a channel \mathcal{B} that adds noise ε to one quadrature. We can compose it with a channel \mathcal{B}' that adds ε of noise to the orthogonal quadrature to get the added noise channel $\mathcal{N} = \mathcal{B}' \circ \mathcal{B}$ with noise parameter ε . Following a pair of channels with another channel on one of the two systems cannot result in an inseparable effective measurement if the original pair makes all effective measurements separable. Since we can make ε arbitrarily small by the squeezing procedure mentioned above, for the purpose of checking whether a pair of channels including a channel of type B_1 allows for inseparable effective measurement, we can treat the type B_1 channel as equivalent to the identity channel. On the other hand, if the other channel together with the identity channel makes all effective measurements separable, then replacing the identity channel with \mathcal{B} cannot change this fact. In conclusion, when combining a channel of type B_1 with another channel, separability of all effective measurements is equivalent to that when the channel of type B_1 is replaced by the identity.

This completes the proof that the procedure stated at the beginning of Sec. V is sufficient to determine, for any pair of single-mode Gaussian channels, whether all effective Gaussian measurements are separable.

VI. PROOF OF PROPOSITION 3 USING DUAL CHANNELS

An alternative method to obtain the inequality in Proposition 3 is to consider dual channels and apply the characterization found in Ref. [27] of pairs of channels that annihilate entanglement of Gaussian states, meaning that the output of every Gaussian input state is separable. If Φ is a channel expressed as a completely positive map from an input state ρ to an output state $\Phi(\rho)$, then the dual channel is the completely positive map Φ^* from input bounded operators Π to output bounded operators $\Phi^*(\Pi)$ such that the following equation holds for all states ρ and all bounded operators Π :

$$\text{tr}[\Phi(\rho)\Pi] = \text{tr}[\rho\Phi^*(\Pi)]. \tag{6.1}$$

For further information about dual Gaussian channels, we refer to Ref. [28]. In particular, we use the fact from Ref. [28] that the dual of a loss channel, when restricted to density operators, is proportional to an amplification channel and vice versa. The proportionality constants do not affect our analyses of separability.

To determine whether a joint Gaussian measurement on modes **A** and **B** after error channels Φ_A and Φ_B results in a separable effective measurement, we can apply the dual channels Φ_A^* and Φ_B^* to the POVM elements of the joint measurement. These POVM elements are proportional to the density operators of Gaussian states, so if $\Phi_A^* \otimes \Phi_B^*$

annihilates entanglement of Gaussian states then the effective measurement is separable. It suffices to check POVM elements that are pure Gaussian states, which can be prepared by applying a Gaussian unitary to vacuum states. Therefore, it suffices to consider circuits of the form

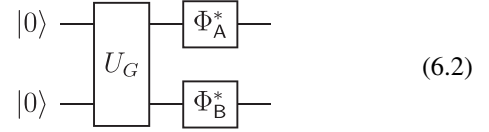

where U_G is an arbitrary Gaussian unitary. The dual of an amplification channel with parameter a is a loss channel with parameter $l^* = 1 - \frac{1}{a}$ and the dual of a loss channel with parameter l is an amplification channel with parameter $a^* = \frac{1}{1-l}$, as stated in Theorem 9 of Ref. [28]. As a result, to obtain the inequality in Proposition 3 it suffices to analyze the circuit in the diagram

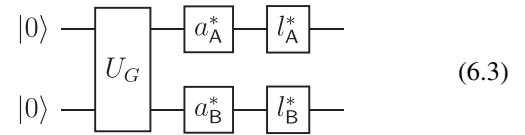

for $a^* = \frac{1}{1-l}$ and $l^* = 1 - \frac{1}{a}$ and determine the parameters at which an arbitrary Gaussian input state becomes separable. Analysis of this scenario appears in Ref. [27]. The single-mode Gaussian channels considered in Ref. [27] are parametrized as $\Phi(\kappa, \mu)$, where the action of $\Phi(\kappa, \mu)$ on covariance matrices is given by

$$V \mapsto \kappa V + \mu \mathbb{1}, \tag{6.4}$$

where κ and μ are non-negative real parameters. This parametrization is general enough to cover any combination of loss, amplification, and added noise as defined in Sec. II. In terms of these parameters, Ref. [27] proves the following condition for entanglement annihilation.

Proposition 7 (from [27]). The channel $\Phi(\kappa_A, \mu_A) \otimes \Phi(\kappa_B, \mu_B)$ annihilates entanglement of all two-mode Gaussian states if and only if $\kappa_A \mu_B + \kappa_B \mu_A \geq \frac{1}{2}(\kappa_A + \kappa_B)$.

If the channels take the form of amplification followed by loss, then this result can be conveniently written according to the following proposition.

Proposition 8. Consider amplification channels with parameters a_A^* and a_B^* followed by loss channels with parameters l_A^* and l_B^* that act independently on an arbitrary two-mode Gaussian pure state on **AB**, as shown in the diagram

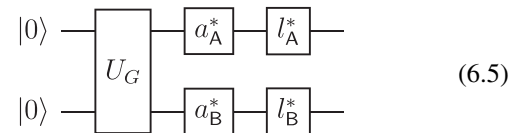

These channels annihilate entanglement of all two-mode Gaussian states if and only if

$$\frac{1}{a_A^*} + \frac{1}{a_B^*} \leq 1. \tag{6.6}$$

Proof. In the notation of Proposition 7, amplification a^* followed by loss l^* is equivalent to $\Phi(\kappa, \mu)$ with

$\kappa = a^*(1 - l^*)$ and $\mu = \kappa/2 + l^* - 1/2$. Substituting κ_i and μ_i for $i \in \{A, B\}$ into the inequality in Proposition 7 leads to

$$\kappa_A \kappa_B \geq \kappa_A(1 - l_B^*) + \kappa_B(1 - l_A^*) \quad (6.7)$$

and further substitution for κ_A and κ_B and cancellation of $(1 - l_A^*)(1 - l_B^*)$ from both sides leads to

$$a_A^* a_B^* \geq a_A^* + a_B^* \quad (6.8)$$

and the result follows. \blacksquare

Now substitution of the dual channel parameters $a^* = \frac{1}{1-l}$ and $l^* = 1 - \frac{1}{a}$ into Eq. (6.6) gives the inequality

$$(1 - l_A) + (1 - l_B) \leq 1, \quad (6.9)$$

which leads directly to the inequality $l_A + l_B \geq 1$, which is independent of amplification parameters as asserted by Proposition 3.

VII. CONCLUSION

We have studied two-mode Gaussian measurements that are made after independent single-mode Gaussian error channels and showed that, if the error channels are amplification with parameters a_A and a_B followed by loss with parameters l_A and l_B , then all effective Gaussian measurements are separable if and only if $l_A + l_B \geq 1$. If the error channels are instead parametrized as loss l_A and l_B followed by noise n_A and n_B , then this condition becomes $l_A + l_B + n_A + n_B \geq 1$. The standard CV Bell measurement is a joint Gaussian measurement that remains inseparable for all error channels whose parameters do not satisfy this inequality. Up to unitary equivalence, all pairs of nontrivial and non-entanglement-breaking single-mode Gaussian channels that act before the Gaussian measurement can be reduced to these cases. In particular, for a given pair of independent single-mode Gaussian error channels this analysis is sufficient to determine whether or not entanglement swapping is possible with a joint Gaussian measurement, even when arbitrary input states are allowed.

Future work can extend this analysis to joint Gaussian measurements on $n > 1$ modes of party A and $m > 1$ modes of party B, to correlated Gaussian error channels, or to non-Gaussian bosonic error channels that are experimentally relevant.

ACKNOWLEDGMENTS

The authors thank A. Avagyan, A. Seshadri, and V. Albert for helpful comments. A. Kwiatkowski, E.S., S.A., A. Kyle, and C.R. acknowledge support from the Professional Research Experience Program (PREP) operated jointly by NIST and the University of Colorado Boulder under Award No. 70NANB18H006 from the U.S. Department of Commerce. This work includes contributions of the National Institute of Standards and Technology, which are not subject to U.S. copyright.

APPENDIX A: THE INEQUALITY IN PROPOSITION 3 IS TIGHT

Proposition 9. For error channels consisting of amplification with parameters a_A and a_B followed by loss with

parameters l_A and l_B , all-Gaussian entanglement swapping is possible if $l_A + l_B < 1$ regardless of the amplification parameters.

Proof. This follows by combining the arguments in Sec. VI with the fact that entanglement swapping using two copies of the infinitely squeezed resource state, given by $\sum_i^\infty |i\rangle \otimes |i\rangle$ in the Fock basis, and conditioning on an outcome of the swapping measurement associated with an inseparable POVM element will necessarily result in an inseparable output state. However, we also provide in this appendix a direct covariance matrix calculation for all-Gaussian entanglement swapping with finitely squeezed resource states and a CV Bell measurement that takes place after amplification and loss channels are applied. We first compute the full four-mode covariance matrix for a pair of two-mode-squeezed states subjected to loss channels with parameters l_A and l_B and amplification channels with parameters a_A and a_B . Then we compute the resulting two-mode covariance matrix after a CV Bell measurement is applied to the modes that experience the amplification and loss. We use the formula from Ref. [6] to compute the post-measurement covariance matrix, which has the form

$$\begin{pmatrix} n_A & 0 & c & 0 \\ 0 & n_A & 0 & -c \\ c & 0 & n_B & 0 \\ 0 & -c & 0 & n_B \end{pmatrix} \quad (A1)$$

for non-negative real parameters n_A , n_B , and c . In terms of a_A , a_B , l_A , and l_B and the two-mode-squeezing parameter r we define for convenience $\kappa_A := a_A(1 - l_A)$, $\kappa_B := a_B(1 - l_B)$, and $\eta := 1 - l_A - l_B$ and find that

$$\begin{aligned} n_A &= \frac{2\kappa_A + \kappa_B + 2(\kappa_A + \kappa_B - 2\eta) \cosh 2r + \kappa_B \cosh 4r}{4[\kappa_A + \kappa_B - 2\eta + (\kappa_A + \kappa_B) \cosh 2r]}, \\ n_B &= \frac{2\kappa_B + \kappa_A + 2(\kappa_A + \kappa_B - 2\eta) \cosh 2r + \kappa_A \cosh 4r}{4[\kappa_A + \kappa_B - 2\eta + (\kappa_A + \kappa_B) \cosh 2r]}, \\ c &= \frac{2\sqrt{\kappa_A \kappa_B} (\cosh r \sinh r)^2}{\kappa_A + \kappa_B - 2\eta + (\kappa_A + \kappa_B) \cosh 2r}. \end{aligned} \quad (A2)$$

According to Theorem 2 from Ref. [46], the state is entangled if and only if the inequality

$$2a^2 n_A + 2\frac{n_B}{a^2} - 4c - a^2 - \frac{1}{a^2} < 0 \quad (A3)$$

is satisfied, where $a^2 := \sqrt{\frac{2n_B - 1}{2n_A - 1}}$. We note that the entries of the covariance matrix in Eq. (A1) are (co)variances of quadratures, while Ref. [46] uses the convention that the analogous covariance matrix's entries are twice the (co)variances of quadratures.

Substituting Eqs. (A2) into Eq. (A3) leads to

$$-2\frac{1 - l_A - l_B}{\sqrt{\kappa_A \kappa_B}} < 0 \quad (A4)$$

in the limit that r goes to infinity. The parameters κ_A and κ_B are non-negative, so this inequality is satisfied when $l_A + l_B < 1$ regardless of a_A and a_B . \blacksquare

APPENDIX B: SEPARABLE MEASUREMENTS CANNOT SWAP OR TELEPORT ENTANGLEMENT

Proposition 10. Consider a joint system of A' , A , B , and B' in an initial state $\rho_{A'ABB'}$ that is separable across the $A'A - B'B$ partition and consider a measurement of the AB subsystem with an outcome associated with some POVM element Π_{AB} that is a convex combination of positive product operators across the $A - B$ partition. Assume for simplicity that the measured system AB is lost after the measurement. The state of the system $A'B'$ after the measurement is separable.

Proof. The unnormalized state after the measurement, denoted by $\sigma_{A'B'}$, is

$$\sigma_{A'B'} = \text{tr}_{AB}(\rho_{A'ABB'} \text{id}_{A'B'} \otimes \Pi_{AB}). \quad (\text{B1})$$

By assumption, the POVM element Π_{AB} can be decomposed as $\sum_i \lambda_i A_i \otimes B_i$ for positive coefficients λ_i and positive

operators A_i and B_i . Furthermore, the initial state $\rho_{A'ABB'}$ is assumed separable and can be decomposed according to $\rho_{A'ABB'} = \sum_j \gamma_j \rho_{A'A} \otimes \rho_{BB'}$ for states $\rho_{A'A}$ and $\rho_{BB'}$ and positive coefficients γ_j . Substituting into Eq. (B1) leads to

$$\sigma_{A'B'} = \sum_{i,j} \lambda_i \gamma_j [\text{tr}_A(\rho_{A'A} \text{id}_{A'} \otimes A_i)] \otimes [\text{tr}_B(\rho_{BB'} B_i \otimes \text{id}_{B'})], \quad (\text{B2})$$

which is separable across the $A' - B'$ partition. ■

Proposition 10 immediately implies that entanglement swapping with a separable measurement on AB cannot generate entanglement across the $A' - B'$ partition. Similarly, if the state of $A'A$ is initially entangled and a separable measurement of AB is used to attempt to teleport the state of system A to the system B' , then Proposition 10 implies that the output state of $A'B'$ is unentangled and therefore entanglement with A' has not been preserved during teleportation.

-
- [1] S. Wehner, D. Elkouss, and R. Hanson, Quantum internet: A vision for the road ahead, *Science* **362**, eaam9288 (2018).
- [2] C. H. Bennett, G. Brassard, C. Crépeau, R. Jozsa, A. Peres, and W. K. Wootters, Teleporting an Unknown Quantum State via Dual Classical and Einstein-Podolsky-Rosen Channels, *Phys. Rev. Lett.* **70**, 1895 (1993).
- [3] S. L. Braunstein and H. J. Kimble, Teleportation of Continuous Quantum Variables, *Phys. Rev. Lett.* **80**, 869 (1998).
- [4] S. L. Braunstein and P. van Loock, Quantum information with continuous variables, *Rev. Mod. Phys.* **77**, 513 (2005).
- [5] P. van Loock and S. L. Braunstein, Unconditional teleportation of continuous-variable entanglement, *Phys. Rev. A* **61**, 010302(R) (1999).
- [6] C. Weedbrook, S. Pirandola, R. García-Patrón, N. J. Cerf, T. C. Ralph, J. H. Shapiro, and S. Lloyd, Gaussian quantum information, *Rev. Mod. Phys.* **84**, 621 (2012).
- [7] G. Adesso, S. Ragy, and A. R. Lee, Continuous variable quantum information: Gaussian states and beyond, *Open Syst. Inf. Dyn.* **21**, 1440001 (2014).
- [8] X. Wang, T. Hiroshima, A. Tomita, and M. Hayashi, Quantum information with Gaussian states, *Phys. Rep.* **448**, 1 (2007).
- [9] M. Abdi, S. Pirandola, P. Tombesi, and D. Vitali, Continuous-variable-entanglement swapping and its local certification: Entangling distant mechanical modes, *Phys. Rev. A* **89**, 022331 (2014).
- [10] S. M. Tan, Confirming entanglement in continuous variable quantum teleportation, *Phys. Rev. A* **60**, 2752 (1999).
- [11] F. Dell'Anno, D. Buono, G. Nocerino, S. D. Siena, and F. Illuminati, Non-Gaussian swapping of entangled resources, *Quantum Inf. Process.* **18**, 20 (2019).
- [12] C. Tian, D. Han, Y. Wang, and X. Su, Connecting two Gaussian cluster states by quantum entanglement swapping, *Opt. Express* **26**, 29159 (2018).
- [13] Y. Lim, J. Joo, T. P. Spiller, and H. Jeong, Loss-resilient photonic entanglement swapping using optical hybrid states, *Phys. Rev. A* **94**, 062337 (2016).
- [14] A. Roy, A. D. Stone, and L. Jiang, Concurrent remote entanglement with quantum error correction against photon losses, *Phys. Rev. A* **94**, 032333 (2016).
- [15] A. Furusawa, J. L. Sørensen, S. L. Braunstein, C. A. Fuchs, H. J. Kimble, and E. S. Polzik, Unconditional quantum teleportation, *Science* **282**, 706 (1998).
- [16] X. Su, C. Tian, X. Deng, Q. Li, C. Xie, and K. Peng, Quantum Entanglement Swapping between Two Multipartite Entangled States, *Phys. Rev. Lett.* **117**, 240503 (2016).
- [17] N. Takei, H. Yonezawa, T. Aoki, and A. Furusawa, High-Fidelity Teleportation beyond the No-Cloning Limit and Entanglement Swapping for Continuous Variables, *Phys. Rev. Lett.* **94**, 220502 (2005).
- [18] X. Jia, X. Su, Q. Pan, J. Gao, C. Xie, and K. Peng, Experimental Demonstration of Unconditional Entanglement Swapping for Continuous Variables, *Phys. Rev. Lett.* **93**, 250503 (2004).
- [19] S. Takeda, M. Fuwa, P. van Loock, and A. Furusawa, Entanglement Swapping between Discrete and Continuous Variables, *Phys. Rev. Lett.* **114**, 100501 (2015).
- [20] S. Takeda, T. Mizuta, M. Fuwa, P. van Loock, and A. Furusawa, Deterministic quantum teleportation of photonic quantum bits by a hybrid technique, *Nature (London)* **500**, 315 (2013).
- [21] A. S. Holevo, One-mode quantum Gaussian channels: Structure and quantum capacity, *Probl. Inf. Transm.* **43**, 1 (2007).
- [22] N. Cerf, G. Leuchs, and E. Polzik, in *Quantum Information with Continuous Variables of Atoms and Light*, edited by N. J. Cerf, G. Leuchs, and E. S. Polzik (World Scientific, Singapore, 2007).
- [23] M. J. W. Hall, Gaussian noise and quantum-optical communication, *Phys. Rev. A* **50**, 3295 (1994).
- [24] K. Noh, S. Pirandola, and L. Jiang, Enhanced energy-constrained quantum communication over bosonic Gaussian channels, *Nat. Commun.* **11**, 457 (2020).
- [25] A. S. Holevo, Structure of a general quantum Gaussian observable, *Proc. Steklov Inst. Math.* **313**, 70 (2021).
- [26] A. S. Holevo, Entanglement-breaking channels in infinite dimensions, *Prob. Inf. Transm.* **44**, 171 (2008).
- [27] S. N. Filippov and M. Ziman, Entanglement sensitivity to signal attenuation and amplification, *Phys. Rev. A* **90**, 010301(R) (2014).
- [28] J. S. Ivan, K. K. Sabapathy, and R. Simon, Operator-sum representation for bosonic Gaussian channels, *Phys. Rev. A* **84**, 042311 (2011).

- [29] M. Allegra, P. Giorda, and M. G. A. Paris, Role of Initial Entanglement and Non-Gaussianity in the Decoherence of Photon-Number Entangled States Evolving in a Noisy Channel, *Phys. Rev. Lett.* **105**, 100503 (2010).
- [30] G. Adesso, Simple proof of the robustness of Gaussian entanglement in bosonic noisy channels, *Phys. Rev. A* **83**, 024301 (2011).
- [31] L.-M. Duan, M. D. Lukin, J. I. Cirac, and P. Zoller, Long-distance quantum communication with atomic ensembles and linear optics, *Nature (London)* **414**, 413 (2001).
- [32] C. L. Rau, A. Kyle, A. Kwiatkowski, E. Shojaei, J. D. Teufel, K. W. Lehnert, and T. Dennis, Entanglement Thresholds of Doubly Parametric Quantum Transducers, *Phys. Rev. Appl.* **17**, 044057 (2022).
- [33] F. Lecocq, L. Ranzani, G. A. Peterson, K. Cicak, A. Metelmann, S. Kotler, R. W. Simmonds, J. D. Teufel, and J. Aumentado, Microwave Measurement beyond the Quantum Limit with a Nonreciprocal Amplifier, *Phys. Rev. Appl.* **13**, 044005 (2020).
- [34] M. Renger, S. Pogorzalek, Q. Chen, Y. Nojiri, K. Inomata, Y. Nakamura, M. Partanen, A. Marx, R. Gross, F. Deppe, and K. G. Fedorov, Beyond the standard quantum limit for parametric amplification of broadband signals, *npj Quantum Inf.* **7**, 160 (2021).
- [35] J. Hoelscher-Obermaier and P. van Loock, Optimal Gaussian entanglement swapping, *Phys. Rev. A* **83**, 012319 (2011).
- [36] S. Pirandola, C. Ottaviani, C. S. Jacobsen, G. Spedalieri, S. L. Braunstein, T. Gehring, and U. L. Andersen, Environment-assisted bosonic quantum communications, *npj Quantum Inf.* **7**, 77 (2021).
- [37] S. Pirandola, D. Vitali, P. Tombesi, and S. Lloyd, Macroscopic Entanglement by Entanglement Swapping, *Phys. Rev. Lett.* **97**, 150403 (2006).
- [38] R. C. Parker, J. Joo, M. Razavi, and T. P. Spiller, Hybrid photonic loss resilient entanglement swapping, *J. Opt.* **19**, 104004 (2017).
- [39] R. C. Parker, J. Joo, and T. P. Spiller, Photonic hybrid state entanglement swapping using cat state superpositions, *Proc. R. Soc. A* **476**, 20200237 (2020).
- [40] M. Silveri, E. Zaly-Geller, M. Hatridge, Z. Leghtas, M. H. Devoret, and S. M. Girvin, Theory of remote entanglement via quantum-limited phase-preserving amplification, *Phys. Rev. A* **93**, 062310 (2016).
- [41] T. Gonzalez-Raya, M. Casariego, F. Fesquet, M. Renger, V. Salari, M. Möttönen, Y. Omar, F. Deppe, K. G. Fedorov, and M. Sanz, Open-Air Microwave Entanglement Distribution for Quantum Teleportation, *Phys. Rev. Appl.* **18**, 044002 (2022).
- [42] B. Zhang, J. Wu, L. Fan, and Q. Zhuang, Entangling Remote Microwave Quantum Computers with Hybrid Entanglement Swap and Variational Distillation, *Phys. Rev. Appl.* **18**, 064016 (2022).
- [43] S. Takeda, T. Mizuta, M. Fuwa, H. Yonezawa, P. van Loock, and A. Furusawa, Gain tuning for continuous-variable quantum teleportation of discrete-variable states, *Phys. Rev. A* **88**, 042327 (2013).
- [44] G. Giedke and J. I. Cirac, Characterization of Gaussian operations and distillation of Gaussian states, *Phys. Rev. A* **66**, 032316 (2002).
- [45] M. A. De Gosson, *Symplectic Geometry and Quantum Mechanics* (Springer Science + Business Media, New York, 2006), Vol. 166.
- [46] L.-M. Duan, G. Giedke, J. I. Cirac, and P. Zoller, Inseparability Criterion for Continuous Variable Systems, *Phys. Rev. Lett.* **84**, 2722 (2000).
- [47] R. Simon, Peres-Horodecki Separability Criterion for Continuous Variable Systems, *Phys. Rev. Lett.* **84**, 2726 (2000).