

Quantum state rotation: Circularly transferring quantum states of multiple usersYonghae Lee^{1,*}, Hayata Yamasaki^{2,3,†} and Soojoon Lee^{1,‡}¹*Department of Mathematics and Research Institute for Basic Sciences, Kyung Hee University, Seoul 02447, Korea*²*Photon Science Center, Graduate School of Engineering, The University of Tokyo, 7-3-1 Hongo, Bunkyo-ku, Tokyo 113-8656, Japan*³*Institute for Quantum Optics and Quantum Information (IQOQI) Vienna, Austrian Academy of Sciences, Boltzmanngasse 3, 1090 Vienna, Austria*

(Received 24 September 2020; accepted 7 June 2021; published 22 June 2021)

Quantum state exchange is a quantum communication task for two users in which the users faithfully exchange their respective parts of an initial state under the asymptotic scenario. In this work, we generalize the quantum state exchange task to a quantum communication task for M users in which the users circularly transfer their respective parts of an initial state. We assume that every pair of users may share entanglement resources, and they use local operations and classical communication in order to perform the task. We call this generalized task the (asymptotic) quantum state rotation. First of all, we formally define the quantum state rotation task and its optimal entanglement cost, which means the least amount of total entanglement required to carry out the task. We then present lower and upper bounds on the optimal entanglement cost, and provide conditions for zero optimal entanglement cost. Based on these results, we find out a difference between the quantum state rotation task for three or more users and the quantum state exchange task.

DOI: [10.1103/PhysRevA.103.062613](https://doi.org/10.1103/PhysRevA.103.062613)**I. INTRODUCTION**

In quantum information theory, some quantum communication tasks [1–8], such as quantum teleportation [1] and quantum state merging [2,3], commonly deal with a two-user setting in which a quantum state is transmitted from one user to the other. In these quantum communication tasks, the users are determined as either a sender or a receiver, as depicted in Fig. 1(a), and it is assumed that the users are in each other's laboratories far apart. So, in order to successfully perform the tasks, it is required to consume nonlocal resources, such as ebits and bit channels.

One of the research topics related to quantum communication tasks is to find out the minimal amounts of the nonlocal resources consumed during the tasks. Such research is considered to be important in quantum information theory, since the minimal amounts can often be represented as entropic quantities, such as the von Neumann entropy and the quantum conditional entropy [9], and hence provides a way to interpret these quantities from an operational viewpoint. For example, the quantum conditional entropy $H(A|B)$ of a quantum state ρ_{AB} can be operationally interpreted as the minimal amount of entanglement needed in the quantum state merging [2,3] in which Alice and Bob share parts A and B of the quantum state ρ_{AB} , respectively, and Alice's part A is merged to Bob via entanglement-assisted local operations and classical communication (LOCC). Note that, in the quantum state merging

task, Bob does not transmit his part B to Alice, but he can use it as quantum side information.

Quantum state exchange (QSE) [10–12], on the other hand, is a more complex quantum communication task in which two users share parts A and B of a quantum state ρ_{AB} , and they exchange their respective parts with each other by means of entanglement-assisted LOCC. Thus, the users of the QSE task do not take one of the roles of a sender and a receiver, but both, as depicted in Fig. 1(b). The main concern of the QSE is to figure out the minimal amount of entanglement between the users under the assumption that classical communication is free. The authors of the original QSE task [10] named the minimal amount of entanglement “uncommon information.” Unlike other quantum communication tasks [1–8], an exact value of the uncommon information is unknown to date.

In this work, we introduce a quantum communication task involving three or more users, which is similar to the rotation in volleyball. In a volleyball game, players rotate on the court when their team makes a serve. Similarly to this rotation, one may think of users of the task and their quantum states as locations of the court and the players, respectively. More specifically, M users of the task transmit their respective quantum states from the i th user to the $(i + 1)$ th user via entanglement-assisted LOCC, while keeping entanglement with an environment system. We call this task quantum state rotation (QSR). We provide a simple illustration of the QSR task for three users in Fig. 2(a). Note that the QSR task for two users, i.e., $M = 2$, is nothing but the QSE task described in Fig. 1(b), since the first user transmits his/her quantum state to the 2nd user, and the first user also receives the second user's quantum state. So the QSR task can be regarded as one possible generalization of the QSE task.

*yonghaelee@khu.ac.kr

†hayata.yamasaki@gmail.com

‡level@khu.ac.kr

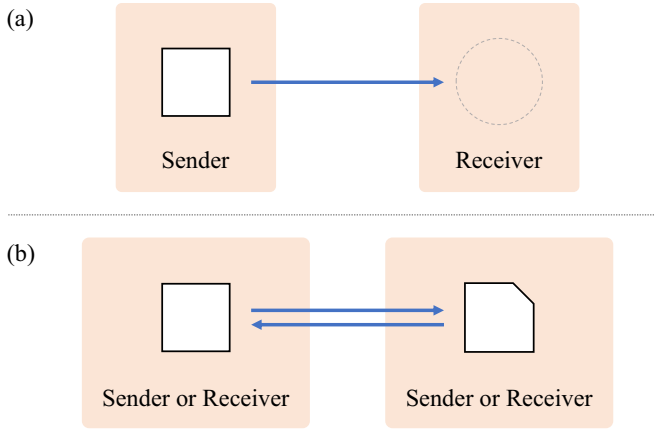

FIG. 1. In these illustrations, quantum states are represented as polygons, and the users transmit their quantum states in the directions of arrows. (a) Illustration of transmitting a quantum state from a sender to a receiver. (b) Illustration of exchanging two quantum states of two users: In this case, each user is not only a sender but also a receiver.

Intuitively, the QSR task for three or more users may be achievable by sequentially performing the QSE tasks for several pairs of the users. For example, as depicted in Fig. 2(b), two QSE tasks among three users can carry out the QSR task for three users. So one may think it is not necessary to conduct a study on the QSR task. However, from the perspective of entanglement resources, it is unclear whether the combination of QSE tasks gives the minimal amount of total entanglement needed in the QSR task, since the uncommon information of the QSE task is unknown. Moreover, the QSR for three or more users might exhibit intrinsic properties of multipartite entanglement, which cannot be understood only by a straightforward generalization of the analysis of the QSE for two users. On this account, the main parts of our work focus on analyzing the minimal amount of total entanglement consumed among the M users for achieving the QSR task.

This paper is organized as follows. In Sec. II, we provide formal descriptions of the QSR task, the achievable total entanglement rate, and the optimal entanglement cost. In Secs. III and IV, we present lower and upper bounds, respectively, on the optimal entanglement cost of the QSR task. In Sec. V, we present conditions obtained by zero optimal entanglement costs and zero achievable total entanglement rates. Based on these results, in Sec. VI, we show that a property of the QSE task does not hold in the QSR task for three or more users. In Sec. VII, we consider two settings of the QSR tasks and investigate what the users should do to reduce the optimal entanglement cost in each setting. In the first setting, some users do not have to participate in the QSR task. In the second, some users can cooperate to achieve the task by performing global operations over the users. In Sec. VIII, we summarize and discuss our results.

II. DEFINITIONS

In this section, we explain notations used throughout this paper, and we describe formal definitions of the QSR task and its optimal entanglement cost.

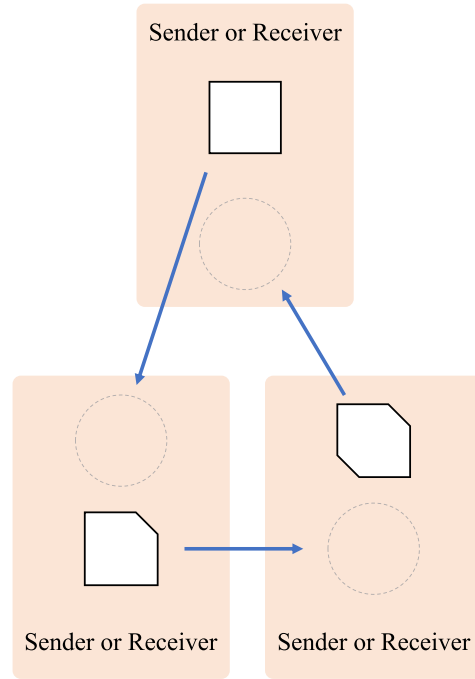

(a)

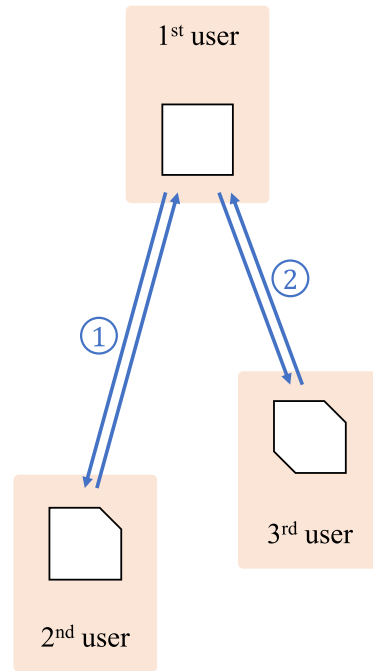

(b)

FIG. 2. In each illustration, quantum states are represented as polygons; users transmit their quantum states in the directions of arrows. (a) Concept of the quantum state rotation task for three users: The users are not only a sender but also a receiver. (b) Performing the quantum state rotation task for three users with a combination of the quantum state exchange tasks: The first user and the second user first exchange their quantum states, and then the first user and the third user perform the quantum state exchange task again. Consequently, these two quantum state exchange tasks carry out the quantum state rotation task for three users.

A. Notations: Systems, states, channels, and entropies

We assume that all Hilbert spaces \mathcal{H} in this paper are finite dimensional, and let d_X denote the dimension of the Hilbert space \mathcal{H}_X representing a quantum system X . A composite quantum system of two quantum systems X and Y is described by the tensor product $\mathcal{H}_X \otimes \mathcal{H}_Y$ of the Hilbert spaces \mathcal{H}_X and \mathcal{H}_Y . For the sake of convenience, the composite quantum system is denoted by $X \otimes Y$ or XY , and d_X is called the dimension of the quantum system X .

Let $\mathcal{D}(\mathcal{H})$ be the set of density operators on a Hilbert space \mathcal{H} , i.e., $\mathcal{D}(\mathcal{H}) = \{\rho \in \mathcal{L}(\mathcal{H}) : \rho \geq 0, \text{Tr } \rho = 1\}$, where $\mathcal{L}(\mathcal{H})$ is the set of linear operators on \mathcal{H} . For a Hilbert space \mathcal{H}_X representing a quantum system X , we use notations $\mathcal{D}(X)$ and $\mathcal{L}(X)$ instead of $\mathcal{D}(\mathcal{H}_X)$ and $\mathcal{L}(\mathcal{H}_X)$, respectively, in order to emphasize the quantum system X . The elements of the set $\mathcal{D}(\mathcal{H})$ are called quantum states. If a quantum state ρ is a rank-1 projector, i.e., it is represented as

$$\psi := |\psi\rangle\langle\psi|, \tag{1}$$

where $|\psi\rangle$ is a normalized vector on the Hilbert space \mathcal{H} , the quantum state is said to be pure. For pure quantum states $|\phi\rangle\langle\phi|$, we also call the unit vector $|\phi\rangle$ a pure quantum state.

For quantum systems X and Y , a map $\mathcal{N} : \mathcal{L}(X) \rightarrow \mathcal{L}(Y)$ is called a quantum channel if it is linear, completely positive, and trace preserving [9]. As a special case of quantum channels, $\text{id}_{\mathcal{L}(X)}$ is the identity map on $\mathcal{L}(X)$. When $\mathcal{L}(X) = \mathcal{L}(Y)$, $\text{id}_{\mathcal{L}(X) \rightarrow \mathcal{L}(Y)}$ means the identity map from $\mathcal{L}(X)$ to $\mathcal{L}(Y)$. For reference, $\mathbb{1}_X$ is the identity matrix on the quantum system X .

The von Neumann entropy $H(\rho)$ of a (pure) quantum state ρ on a quantum system X is defined as $H(\rho) = H(X)_\rho = -\text{Tr } \rho \log \rho$. For a (pure) quantum state σ on a bipartite quantum system XY , the von Neumann entropy $H(X)_\sigma$ of σ on the subsystem X is calculated as $H(X)_\sigma = H(\text{Tr}_Y \sigma)$. Then the quantum conditional entropy $H(X|Y)_\sigma$ and the quantum mutual information $I(X;Y)_\sigma$ of the bipartite quantum state σ are given by

$$H(X|Y)_\sigma = H(XY)_\sigma - H(Y)_\sigma, \tag{2}$$

$$I(X;Y)_\sigma = H(X)_\sigma + H(Y)_\sigma - H(XY)_\sigma. \tag{3}$$

Finally, the number of users of the QSR task is denoted by a natural number $M \geq 2$. If the i th user has a quantum system X_i for each i in the set $[M] = \{1, 2, \dots, M\}$, then the addition of two indices is defined modulo M , with offset 1.

B. Formal description of quantum state rotation

Before describing definitions of the QSR task, we briefly explain a conception of the QSR task. The QSR is a quantum communication task for M users. The users initially share an M -partite quantum state, and circularly transfer their respective quantum states from the i th user to the $(i + 1)$ th user via entanglement-assisted LOCC.

To be specific, let $|\psi\rangle_{AE}$ be the *initial state* of the QSR task, where A is an M -partite quantum system with $A = A_1 A_2 \dots A_M$, and E is the environment system. Assume that the i th user holds a quantum subsystem A_i of A , so that the i th user has the i th part of the initial state $|\psi\rangle_{AE}$. Let us now consider an M -partite quantum system A' with $A' = A'_1 A'_2 \dots A'_M$ and $\mathcal{H}_{A'_i} = \mathcal{H}_{A_i}$, and assume that the i th user holds a quantum

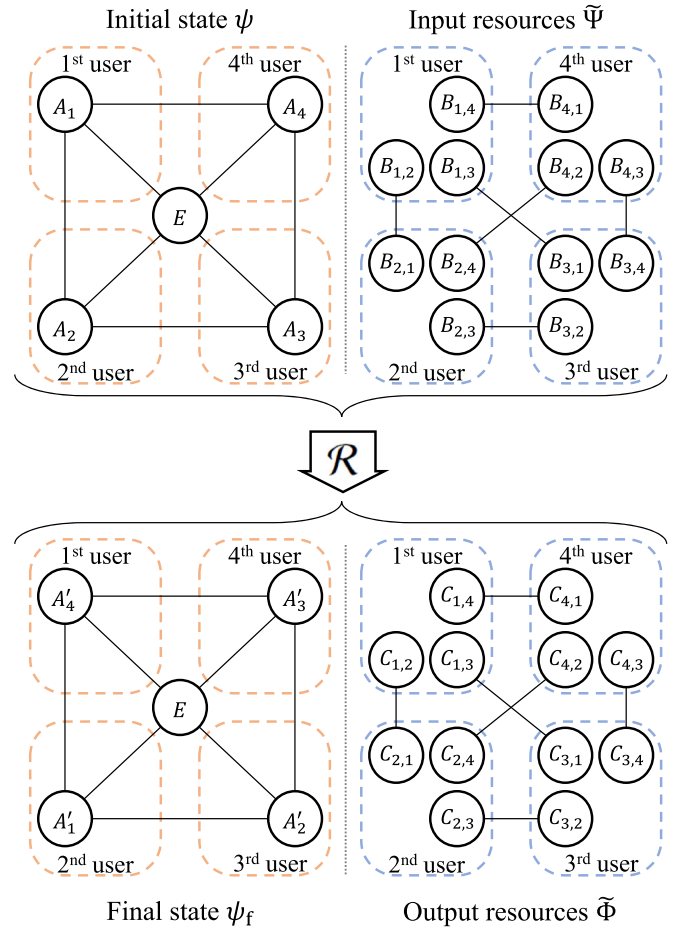

FIG. 3. Illustration of the quantum state rotation task for four users: Circles indicate quantum systems for the task, and correlations among the quantum systems are represented by lines connecting them. In this task, four users want to transform an initial state $|\psi\rangle_{A_1 A_2 A_3 A_4 E}$ into a final state $|\psi_f\rangle_{A'_1 A'_2 A'_3 A'_4 E}$. To carry out this task, they apply LOCC \mathcal{R} to the initial state ψ and input entanglement resources $\tilde{\Psi}$, while they cannot apply any operations on the environment system E . After the task, the i th user's quantum state is transmitted to the $(i + 1)$ th user's quantum system A'_i , and they can gain output entanglement resources $\tilde{\Phi}$ from the task. The allocation of entanglement resources, such as $\tilde{\Psi}$ and $\tilde{\Phi}$, is called the complete entanglement allocation.

subsystem A'_{i-1} of A' . Then the *final state* $|\psi_f\rangle_{A'E}$ of the QSR task is defined by using $|\psi\rangle_{AE}$ as follows:

$$\psi_f = \left(\bigotimes_{i=1}^M \text{id}_{\mathcal{L}(A_i) \rightarrow \mathcal{L}(A'_i)} \otimes \text{id}_{\mathcal{L}(E)} \right) (\psi), \tag{4}$$

which means that the i th user's quantum state on the quantum system A_i is transferred to the $(i + 1)$ th user's quantum system A'_i . The initial state and the final state for four users, i.e., $M = 4$, are presented in Fig. 3.

In the QSR task, the users make use of LOCC assisted by shared entanglement, in order to transform the initial state $|\psi\rangle_{AE}$ into the final state $|\psi_f\rangle_{A'E}$. In this work, we assume that every two of the M users of the QSR task may share an entanglement resource of varying dimensions. More specifically, for each $i \neq j$, the i th user and the j th user have

additional quantum systems $B_{i,j}$ and $B_{j,i}$, respectively, whose dimensions are the same, and the two users share a bipartite maximally entangled state $|\Psi_{i,j}\rangle$ on the quantum systems $B_{i,j}B_{j,i}$ given by

$$|\Psi_{i,j}\rangle = \frac{1}{\sqrt{d_{B_{i,j}}}} \sum_{k=0}^{d_{B_{i,j}}-1} |k\rangle_{B_{i,j}} \otimes |k\rangle_{B_{j,i}}. \quad (5)$$

As in other quantum communication tasks [2–8,10–12], the users of the QSR task may gain extra entanglement resources from the QSR task. To describe these entanglement resources, we also assume that, for each $i \neq j$, the i th user and the j th user have quantum systems $C_{i,j}$ and $C_{j,i}$, respectively, with $d_{C_{i,j}} = d_{C_{j,i}}$, and they share a bipartite maximally entangled state $|\Phi_{i,j}\rangle$ on the quantum systems $C_{i,j}C_{j,i}$ as an entanglement resource after the QSR task, i.e.,

$$|\Phi_{i,j}\rangle = \frac{1}{\sqrt{d_{C_{i,j}}}} \sum_{k=0}^{d_{C_{i,j}}-1} |k\rangle_{C_{i,j}} \otimes |k\rangle_{C_{j,i}}. \quad (6)$$

Let $\tilde{\Psi}$ and $\tilde{\Phi}$ be global quantum states representing all entanglement resources shared among the M users before and after the QSR task, respectively, which are defined as

$$\tilde{\Psi} = \bigotimes_{\substack{i,j \in [M] \\ i < j}} \Psi_{i,j} \quad \text{and} \quad \tilde{\Phi} = \bigotimes_{\substack{i,j \in [M] \\ i < j}} \Phi_{i,j}. \quad (7)$$

The shapes of entanglement resources $\tilde{\Psi}$ and $\tilde{\Phi}$ correspond to a complete graph, if we regard the M users and their entanglement resources as vertices and edges of a graph, respectively. In this work, we call such a resource allocation of entangled states the *complete entanglement allocation*, and the complete entanglement allocation for four users is described in Fig. 3.

In the QSR task, a quantum channel

$$\mathcal{R} : \mathcal{L}\left(\bigotimes_{i=1}^M A_i B_i\right) \longrightarrow \mathcal{L}\left(\bigotimes_{i=1}^M A'_i C_i\right) \quad (8)$$

is called the *QSR protocol* of the initial state $|\psi\rangle_{AE}$ with error ε , if it is performed by LOCC among the M users and satisfies

$$\|(\mathcal{R} \otimes \text{id}_{\mathcal{L}(E)})(\psi \otimes \tilde{\Psi}) - \psi_f \otimes \tilde{\Phi}\|_1 \leq \varepsilon, \quad (9)$$

where quantum systems B_i and C_i are defined by

$$B_i = \bigotimes_{j \in [M] \setminus \{i\}} B_{i,j} \quad \text{and} \quad C_i = \bigotimes_{j \in [M] \setminus \{i\}} C_{i,j}, \quad (10)$$

and $\|\cdot\|_1$ is the trace norm [9].

C. Optimal entanglement cost of quantum state rotation

To investigate asymptotic limits for the total amount of entanglement, we consider a sequence $\{\mathcal{R}_n\}_{n \in \mathbb{N}}$ of QSR protocols \mathcal{R}_n of $\psi^{\otimes n}$ with error ε_n , where $\psi^{\otimes n}$ indicates the n copies of the initial state ψ . We call the case dealing with sequences of QSR protocols an *asymptotic scenario*.

According to the number of the initial state and the users' strategies in the asymptotic scenario, the total amount of entanglement consumed or gained among the users can differ. To reflect this, it is assumed that, for each n , the i th user and the j th user have additional quantum systems $B_{i,j}^{(n)}C_{i,j}^{(n)}$ and $B_{j,i}^{(n)}C_{j,i}^{(n)}$, respectively, where $d_{B_{i,j}^{(n)}} = d_{B_{j,i}^{(n)}}$ and $d_{C_{i,j}^{(n)}} = d_{C_{j,i}^{(n)}}$, and

the two users share bipartite maximally entangled states $|\Psi_{i,j}^{(n)}\rangle$ and $|\Phi_{i,j}^{(n)}\rangle$ on the quantum systems $B_{i,j}^{(n)}B_{j,i}^{(n)}$ and $C_{i,j}^{(n)}C_{j,i}^{(n)}$, respectively. In this case, for each n , the complete entanglement allocations before and after the QSR protocol \mathcal{R}_n of $\psi^{\otimes n}$ with error ε_n are represented as $\tilde{\Psi}_n$ and $\tilde{\Phi}_n$, respectively.

For the initial state ψ and the sequence $\{\mathcal{R}_n\}$, we define the *segment entanglement rate* $e_{i,j}(\psi, \{\mathcal{R}_n\})$ between the i th user and the j th user as

$$e_{i,j}(\psi, \{\mathcal{R}_n\}) = \lim_{n \rightarrow \infty} \frac{1}{n} (\log d_{B_{i,j}^{(n)}} - \log d_{C_{i,j}^{(n)}}), \quad (11)$$

where $i \neq j$, and logarithms are taken to base 2 throughout this paper. For convenience, we define $e_{i,i}(\psi, \{\mathcal{R}_n\})$ as zero for each i . Note that $e_{j,i}(\psi, \{\mathcal{R}_n\}) = e_{i,j}(\psi, \{\mathcal{R}_n\})$ holds for each i, j . If the segment entanglement rate $e_{i,j}(\psi, \{\mathcal{R}_n\})$ converges for each $i \neq j$, then we can define the *total entanglement rate* $e_{\text{tot}}(\psi, \{\mathcal{R}_n\})$ as

$$e_{\text{tot}}(\psi, \{\mathcal{R}_n\}) = \sum_{\substack{i,j \in [M] \\ i < j}} e_{i,j}(\psi, \{\mathcal{R}_n\}). \quad (12)$$

A real number r is said to be an (asymptotically) *achievable* total entanglement rate, if there is a sequence $\{\mathcal{R}_n\}_{n \in \mathbb{N}}$ of QSR protocols \mathcal{R}_n of $\psi^{\otimes n}$ with error ε_n such that (i) for any i, j , $e_{i,j}(\psi, \{\mathcal{R}_n\})$ converges; (ii) $e_{\text{tot}}(\psi, \{\mathcal{R}_n\}) = r$; and (iii) $\lim_{n \rightarrow \infty} \varepsilon_n = 0$. The *optimal entanglement cost* (OEC) $e_{\text{opt}}(\psi)$ of the QSR task for ψ is defined as the infimum of the achievable total entanglement rates.

Remark 1. In the QSR task, the users obtain the final state ψ_f and the output entanglement resources $\tilde{\Phi}$ by applying the QSR protocol to the initial state ψ and the input entanglement resources $\tilde{\Psi}$. Note that the QSR protocol is LOCC, and the initial state ψ and the final state ψ_f have the same amount of entanglement, since ψ_f is defined by using ψ and identity maps. So, it is obvious that the total amount of entanglement among the users does not increase on average via the QSR protocol. As a measure that fulfills this condition, we use the total entanglement rate e_{tot} in this work. The total entanglement rate e_{tot} measures the total amount of entanglement between pairs of the users. In addition, we will see the non-negativity of the total entanglement rate in Remark 4. On this account, the total entanglement rate is a valid measure for analyzing the total amount of entanglement required for the QSR task.

For example, let us consider a simple initial state

$$|\phi_1\rangle_A = |\varphi_1\rangle_{A_1 A_2} \otimes |\varphi_2\rangle_{A_3}, \quad (13)$$

where E is regarded as a one-dimensional system, $|\varphi_1\rangle$ is any two-qubit entangled state, and $|\varphi_2\rangle$ is any quantum state. We provide illustrations of the initial state ϕ_1 and its final state in Fig. 4. For the initial state ϕ_1 , we can calculate the segment entanglement rates $e_{i,j}$ and the total entanglement rate e_{tot} through the following strategy.

(i) In order to rotate ϕ_1 , the second user locally prepares a two-qubit state $|\varphi_1\rangle$, which is not the original state $|\varphi_1\rangle$ on the quantum systems $A_1 A_2$, and asymptotically transfers one qubit of the new state to the third user by using Schumacher compression [9,16] and the quantum teleportation [1]. From this, the second user and the third user can share the state

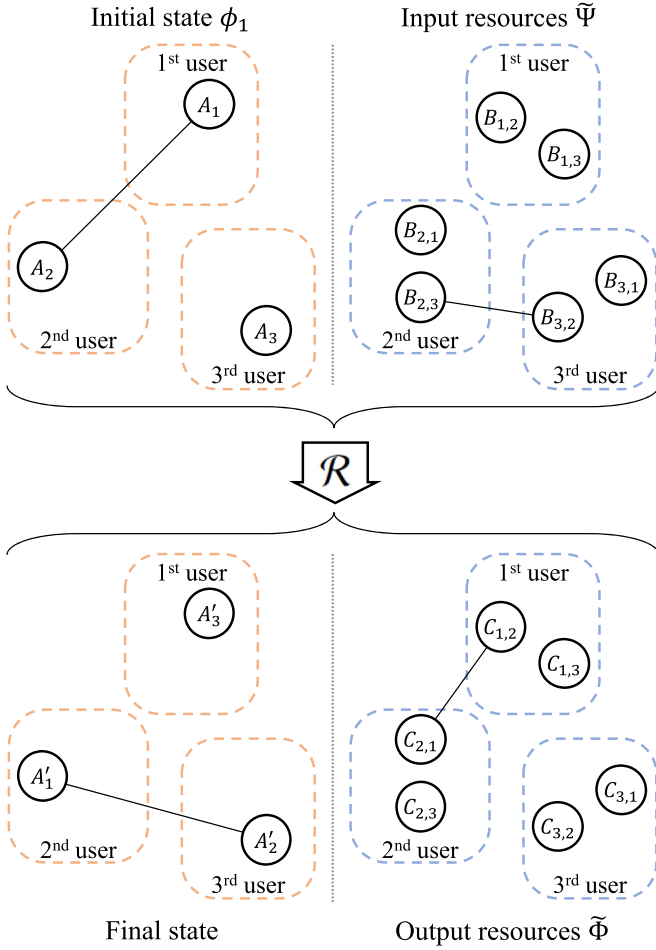

FIG. 4. Initial state ϕ_1 in Eq. (13), its final state, and input and output entanglement resources: Circles indicate quantum systems, and correlations among the quantum systems are represented by lines connecting them. In order to rotate ϕ_1 , the second user locally prepares the two-qubit entangled state ϕ_1 , and transfers one qubit of ϕ_1 to the third user, so they can share ϕ_1 on quantum systems $A'_1 A'_2$. For this, the amount of entanglement consumed by them is $H(A_1)_{\phi_1}$. Then the first user and the second user asymptotically generate the same amount of entanglement by applying entanglement distillation [13–15] to ϕ_1 on quantum systems $A_1 A_2$. Finally, the first user locally prepares the pure quantum state ϕ_2 on the system A'_3 . In an illustration for input (output) entanglement resources, two circles connected by a line indicate consumed (gained) entanglement whose amount is $H(A_1)_{\phi_1}$.

$|\phi_1\rangle$ on the systems $A'_1 A'_2$, and the amount of entanglement consumed by them is $H(A_1)_{\phi_1}$.

(ii) Since the quantum state $|\phi_1\rangle$ is already distributed to the second user and the third user, the original state $|\phi_1\rangle$ of the first user and the second user is now superfluous, but it can be transformed into an output entanglement resource of the QSR task. In other words, the first user and the second user asymptotically generate $H(A_1)_{\phi_1}$ amount of entanglement by applying entanglement distillation [13–15] to their state $|\phi_1\rangle_{A_1 A_2}$.

(iii) Finally, the first user locally prepares the pure quantum state $|\phi_2\rangle$. This preparation neither requires nor generates any entanglement resources. To be specific, this strategy can

be represented as a sequence $\{\mathcal{R}_n\}$ of QSR protocols of ϕ_1 whose segment entanglement rates are

$$e_{1,2}(\phi_1, \{\mathcal{R}_n\}) = -H(A_1)_{\phi_1}, \quad (14)$$

$$e_{2,3}(\phi_1, \{\mathcal{R}_n\}) = H(A_1)_{\phi_1}, \quad (15)$$

$$e_{3,1}(\phi_1, \{\mathcal{R}_n\}) = 0, \quad (16)$$

and so the total entanglement rate is zero, i.e., $e_{\text{tot}}(\phi_1, \{\mathcal{R}_n\}) = 0$. The positive (negative) segment entanglement rate is described in Fig. 4.

III. LOWER BOUND

In this section, we present a lower bound on the OEC of the QSR task. For a nonempty proper subset P of the set $[M]$ and the initial state $|\psi\rangle_{AE}$ with $A = A_1 A_2 \cdots A_M$, we consider a quantity $l_P(\psi)$ defined as

$$l_P(\psi) = \max_U \left\{ H \left(\bigotimes_{i \in P} A_{i-1} V \right)_{U|\psi} - H \left(\bigotimes_{i \in P} A_i V \right)_{U|\psi} \right\}, \quad (17)$$

where the maximum is taken over all isometries U from E to $V \otimes W$ [9], V and W are any quantum systems, and $U|\psi\rangle$ is an abbreviation for $\mathbb{1}_A \otimes U|\psi\rangle$. Note that, for any partition $\{P, P^c\}$ of the set $[M]$, $l_P(\psi) = l_{P^c}(\psi)$ holds. The quantity $l_P(\psi)$ is a lower bound on the sum of the segment entanglement rate as follows:

Lemma 2. For the initial state $|\psi\rangle_{AE}$ and the partition $\{P, P^c\}$ of the set $[M]$, the following inequality holds:

$$\sum_{i \in P} \sum_{j \in P^c} e_{i,j}(\psi, \{\mathcal{R}_n\}) \geq l_P(\psi), \quad (18)$$

where the segment entanglement rate $e_{i,j}$ is defined in Eq. (11), and $\{\mathcal{R}_n\}_{n \in \mathbb{N}}$ is a sequence of QSR protocols \mathcal{R}_n of $\psi^{\otimes n}$ with error ϵ_n whose total entanglement rate is achievable.

A detailed description of the quantity $l_P(\psi)$ and the proof of Lemma 2 are presented in Appendix A. By using Lemma 2, we obtain the following theorem providing a lower bound on any achievable total entanglement rate of the QSR task.

Theorem 3. Let $|\psi\rangle_{AE}$ be the initial state of the QSR task with $A = A_1 A_2 \cdots A_M$. Any achievable total entanglement rate r of the QSR task is lower bounded by

$$r \geq l_k(\psi) := \frac{1}{2^{\binom{M-2}{k-1}}} \sum_{P \in S_k} l_P(\psi), \quad (19)$$

where $1 \leq k < M$, S_k is the set of subsets P of $[M]$ whose sizes are k , i.e., $|P| = k$, and $l_P(\psi)$ is given in Eq. (17).

We refer the reader to Appendix B for the proof of Theorem 3. Theorem 3 implies that the OEC $e_{\text{opt}}(\psi)$ of the initial state ψ is lower bounded by

$$e_{\text{opt}}(\psi) \geq l(\psi) := \max_{1 \leq k \leq \lfloor \frac{M}{2} \rfloor} l_k(\psi), \quad (20)$$

where $\lfloor x \rfloor$ denotes the floor function defined as $\max\{m \in \mathbb{Z} : m \leq x\}$.

Remark 4. The lower bounds $l_i(\psi)$ are non-negative, since, for each i ,

$$\begin{aligned} \sum_{P \in \mathcal{S}_i} l_P(\psi) &\geq \sum_{P \in \mathcal{S}_i} \left[H\left(\bigotimes_{j \in P} A_{j-1}\right)_\psi - H\left(\bigotimes_{j \in P} A_j\right)_\psi \right] \quad (21) \\ &= \sum_{P \in \mathcal{S}_i} H\left(\bigotimes_{j \in P} A_j\right)_\psi - \sum_{P \in \mathcal{S}_i} H\left(\bigotimes_{j \in P} A_j\right)_\psi = 0. \quad (22) \end{aligned}$$

Thus, the OEC cannot be negative, i.e., $e_{\text{opt}}(\psi) \geq 0$. This means that the total amount of entanglement gained from the QSR task cannot exceed that of entanglement resources consumed in the task.

In this work, while we analyze the OEC as a figure of merit, the case of zero OECs, $e_{\text{opt}} = 0$, does not necessarily mean that the related segment entanglement rates are zero, i.e., $e_{i,j} = 0$ for each $i \neq j$, as shown in Eqs. (14) and (15). In general, entanglement resources for the QSR task may be consumed by some pair of users while distilled by another pair, as in the example of Remark 1.

Remark 5. One of our contributions is to generalize results of the QSE task [10] to the general cases including more than two users. To be specific, Remark 4 implies the non-negativity of the OEC for the QSE task. For $M = 2$, the lower bound $l(\psi)$ in Eq. (20) becomes

$$l(\psi) = \max_U \{H(A_1V)_{U|\psi} - H(A_2V)_{U|\psi}\} \quad (23)$$

$$= \max_{\mathcal{N}} \{H(A_1V)_{\mathcal{N}(\psi)} - H(A_2V)_{\mathcal{N}(\psi)}\}, \quad (24)$$

where V is any quantum system, \mathcal{N} is any quantum channel from $\mathcal{L}(E)$ to $\mathcal{L}(V)$, and $\mathcal{N}(\psi)$ is an abbreviation for $(\mathbb{1}_{\mathcal{L}(A)} \otimes \mathcal{N})(\psi)$. The first equality comes from $l_{\{1\}}(\psi) = l_{\{2\}}(\psi)$. The second equality holds, since there is a one-to-one correspondence between isometries U and quantum channels \mathcal{N} . That is, any isometry $U : E \rightarrow V \otimes W$ combined with the partial trace over the quantum system W becomes a quantum channel $\mathcal{N} : E \rightarrow V$, and for any quantum channel \mathcal{N} , we can find its isometric extension U [9]. The above quantity is the lower bound on the OEC for the QSE task presented in Ref. [10].

IV. ACHIEVABLE UPPER BOUND

In this section, we present an achievable upper bound on the OEC of the QSR task by considering a specific strategy.

The QSR task can be carried out by using an M -partite merge-and-send strategy. We can obtain this strategy by generalizing the merge-and-send strategy presented in Ref. [10]. The idea of the M -partite merge-and-send strategy is as follows:

(i) The first user and the second user of the QSR task merge the part A_1 to the second user by using quantum state merging [2,3]. In this case, the part A_2 of the second user acts as the quantum side information. After finishing merging A_1 , the second user considers his or her part A_1 as a part of the environment system. Then the second user and the third user can make use of the quantum state merging protocol again, in order to merge A_2 . In this way, the part A_i is sequentially merged from the i th user to the $(i + 1)$ th user except for the last part A_M .

(ii) Finally, the last user and the first user perform Schumacher compression [9,16] together with quantum teleportation [1] in order to transfer the part A_M to the first user. Through this strategy, the M users can rotate any initial state of the QSR task. Note that instead of using quantum state merging [2,3], the M users can apply quantum state redistribution [6,7] with quantum teleportation [1] in order to perform the QSR task. In this case, the total amount of entanglement is identical to that of the M -partite merge-and-send strategy, while the amounts of classical communication can be different.

When the users adopt the above M -partite merge-and-send strategy, for each $i \in [M - 1]$, the entanglement cost of merging A_i is represented as $H(A_i|A_{i+1})_\psi$, and the entanglement cost for transferring A_M is $H(A_M)_\psi$. In other words, these entanglement costs can be represented in terms of the segment entanglement rates as follows.

Lemma 6. For any initial state $|\psi\rangle_{AE}$ of the QSR task with $A = A_1A_2 \cdots A_M$, there is a sequence $\{\mathcal{R}_n\}_{n \in \mathbb{N}}$ of QSR protocols \mathcal{R}_n of $\psi^{\otimes n}$ with error ε_n such that $\lim_{n \rightarrow \infty} \varepsilon_n = 0$,

$$e_{i,j}(\psi, \{\mathcal{R}_n\}) = \begin{cases} H(A_i|A_{i+1})_\psi & \text{if } i \in [M - 1] \text{ and } j = i + 1 \\ H(A_M)_\psi & \text{if } i = M \text{ and } j = 1 \\ 0 & \text{otherwise,} \end{cases} \quad (25)$$

$$e_{\text{tot}}(\psi, \{\mathcal{R}_n\}) = H(A_M)_\psi + \sum_{i=1}^{M-1} H(A_i|A_{i+1})_\psi. \quad (26)$$

In order to prove Lemma 6, we apply a technique presented in Ref. [11], which is used to show the existence of the merge-and-merge protocol therein, and we refer the reader to Appendix C for the proof of Lemma 6.

By using Lemma 6, we obtain the following theorem, which provides an achievable upper bound on the OEC of the QSR task.

Theorem 7. Let $|\psi\rangle_{AE}$ be the initial state for the QSR task with $A = A_1A_2 \cdots A_M$. The OEC $e_{\text{opt}}(\psi)$ is upper bounded by

$$u(\psi) := \sum_{i=1}^M H(A_i|A_{i+1})_\psi + \min_{1 \leq i \leq M} I(A_i; A_{i+1})_\psi. \quad (27)$$

Proof. For each $i \in [M]$, we consider an M -partite merge-and-send strategy in which the part A_i is first merged from the i th user to the $(i + 1)$ th user and the part A_{i-1} is last sent from the $(i - 1)$ th user to the i th user. From Lemma 6, the achievable total entanglement rate $u_i(\psi)$ for this strategy is given by

$$u_i(\psi) = H(A_{i-1})_\psi + \sum_{j \in [M] \setminus \{i-1\}} H(A_j|A_{j+1})_\psi \quad (28)$$

$$= I(A_i; A_{i-1})_\psi + \sum_{j \in [M]} H(A_j|A_{j+1})_\psi. \quad (29)$$

It follows that $e_{\text{opt}}(\psi) \leq \min_{1 \leq i \leq M} u_i(\psi)$, from optimizing the choice of the first user starting the merge-and-send strategy. ■

Remark 8. By using the lower bound in Eq. (20) and Theorem 7, we can exactly evaluate the OECs for some initial

states. For example, let us consider an initial state

$$|\phi_2\rangle_{AE} = \bigotimes_{i=1}^M |\varphi_i\rangle_{A_i E_i}, \quad (30)$$

where $E = E_1 E_2 \cdots E_M$, and $|\varphi_i\rangle$ is any pure bipartite entangled state on the quantum systems $A_i E_i$. Then, from the lower bound in Eq. (20), the OEC $e_{\text{opt}}(\phi_2)$ is lower bounded by

$$l_1(\phi_2) = \frac{1}{2} \sum_{i=1}^M \max_U \{H(A_{i-1}V)_{U|\phi_2} - H(A_i V)_{U|\phi_2}\}, \quad (31)$$

where l_1 is defined in Theorem 3, and $U|\phi_2$ is an abbreviation for $\mathbb{1}_A \otimes U|\phi_2$. So, $e_{\text{opt}}(\phi_2)$ is lower bounded by

$$e_{\text{opt}}(\phi_2) \geq \frac{1}{2} \sum_{i=1}^M [H(A_{i-1}E_i)_{\phi_2} - H(A_i E_i)_{\phi_2}] = \sum_{i=1}^M H(A_i)_{\varphi_i}, \quad (32)$$

if we consider isometries $U_i : E \rightarrow E_i \otimes (E \setminus E_i)$ with $i \in [M]$ such that $\text{Tr}_{E \setminus E_i} U_i \phi_2 U_i^\dagger = \text{Tr}_{E \setminus E_i} \phi_2$, where $E \setminus E_i = E_1 \cdots E_{i-1} E_{i+1} \cdots E_M$. Moreover, from Theorem 7, we have

$$e_{\text{opt}}(\phi_2) \leq u(\phi_2) = \sum_{i=1}^M H(A_i)_{\varphi_i}. \quad (33)$$

Hence, $e_{\text{opt}}(\phi_2) = \sum_{i=1}^M H(A_i)_{\varphi_i}$.

Remark 9. In general, the M -partite merge-and-send strategy is not necessarily the optimal strategy, although we have used it in order to find the OEC for the specific initial state in Remark 8. As a counterexample of the optimality, let us consider an initial state

$$|\phi_3\rangle_A = |\varphi_1\rangle_{A_1 A_3} \otimes |\varphi_2\rangle_{A_2} \otimes |\varphi_3\rangle_{A_4}, \quad (34)$$

where $|\varphi_1\rangle$ is any pure two-qubit entangled state, and $|\varphi_2\rangle$ and $|\varphi_3\rangle$ are any pure quantum states. Here, E is regarded as a one-dimensional system. If we apply the M -partite merge-and-send strategy to the initial state $|\phi_3\rangle_A$, then we obtain $u(\phi_3) = 2H(A_1)_{\varphi_1}$ from Theorem 7.

However, using the strategy presented in Remark 1, we obtain an achievable upper bound smaller than $u(\phi_3)$. To be specific, the second user locally prepares the two-qubit entangled state φ_1 , and transfers one qubit of the state to the fourth user by consuming as much entanglement as $H(A_1)_{\varphi_1}$. The first user and the third user then generate the same amount of entanglement by distilling their state φ_1 on the quantum systems $A_1 A_3$. Finally, the first user and the third user locally prepare pure states φ_3 and φ_2 , respectively, without consuming and gaining any entanglement resource. This strategy can be represented as a sequence $\{\mathcal{R}_n\}$ of QSR protocols of ϕ_3 whose segment entanglement rates are zero except for $e_{1,3}(\phi_3, \{\mathcal{R}_n\}) = -H(A_1)_{\varphi_1}$ and $e_{2,4}(\phi_3, \{\mathcal{R}_n\}) = H(A_1)_{\varphi_1}$, and $e_{\text{tot}}(\phi_3, \{\mathcal{R}_n\}) = 0$. It follows that $e_{\text{tot}}(\phi_3, \{\mathcal{R}_n\}) < u(\phi_3)$, since φ_1 is entangled. This shows that the M -partite merge-and-send strategy is not optimal in general. In addition, the non-negativity of the OEC implies $e_{\text{opt}}(\phi_3) = 0$ in this case.

Remark 10. Throughout this paper, we have been assuming that the users of the QSR task make use of the complete entanglement allocation. However, one may think that it suffices to consider bipartite entanglement resources between the

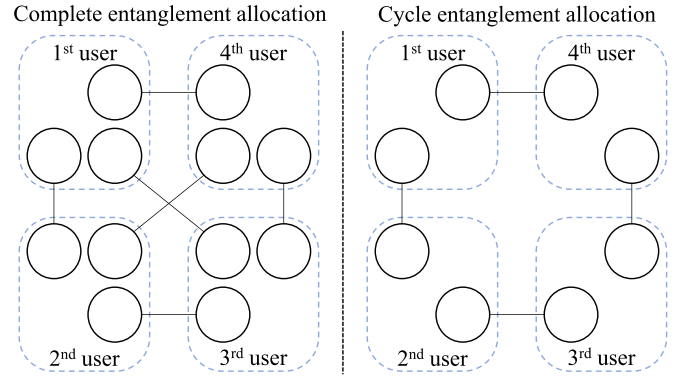

FIG. 5. Illustrations of the complete entanglement allocation and the cycle entanglement allocation for four users: An entanglement resource between two users is represented as two circles connected by a line. Under the complete entanglement allocation, every pair of four users can freely consume and generate entanglement resource. However, under the cycle entanglement allocation, only the i th user and the $(i+1)$ th user can manipulate entanglement resources, and the i th user and the $(i+2)$ th user are not allowed to deal with any entanglement resources.

i th user and the $(i+1)$ th user for each i , since the i th user transfers his or her quantum state to the $(i+1)$ th user in the M -partite merge-and-send strategy. Here, we call such an allocation of entanglement resources the *cycle entanglement allocation*, and we provide illustrations explaining how four users share entanglement resources according to the complete entanglement allocation and the cycle entanglement allocation in Fig. 5.

The initial state ϕ_3 in Eq. (34) shows that, under the complete entanglement allocation setting, the users can reduce the total amount of entanglement for the QSR task compared to the case that the users use the cycle entanglement allocation for rotating the same initial state.

To see this reduction, we evaluate a lower bound on the OEC for rotating ϕ_3 , when the users use the cycle entanglement allocation. This means that the first (second) user and the third (fourth) user cannot employ any entanglement resource between them, as depicted in Fig. 5. Let $\{\mathcal{C}_n\}_{n \in \mathbb{N}}$ be a sequence of such protocols \mathcal{C}_n rotating $\phi_3^{\otimes n}$ with error ε_n , where the users of each protocol use the cycle entanglement allocation. While there is no need to consider the segment entanglement rates $e_{1,3}(\phi_3, \{\mathcal{C}_n\})$ and $e_{2,4}(\phi_3, \{\mathcal{C}_n\})$ in this case, we assume that $e_{1,3}(\phi_3, \{\mathcal{C}_n\}) = e_{2,4}(\phi_3, \{\mathcal{C}_n\}) = 0$, in order to regard the protocol \mathcal{C}_n as the special case of the QSR protocol. Recall that the state ϕ_3 has no further environment system E , as shown in Eq. (34). Then, from Lemma 2, we obtain that the inequality

$$e_{i,i-1}(\phi_3, \{\mathcal{C}_n\}) + e_{i,i+1}(\phi_3, \{\mathcal{C}_n\}) \geq l_{[i]}(\phi_3) \quad (35)$$

holds for each $1 \leq i \leq 4$. By using this inequality and the definition of e_{tot} in Eq. (12), we obtain

$$e_{\text{tot}}(\phi_3, \{\mathcal{C}_n\}) \geq l_{\{1\}}(\phi_3) + l_{\{3\}}(\phi_3), \quad (36)$$

$$e_{\text{tot}}(\phi_3, \{\mathcal{C}_n\}) \geq l_{\{2\}}(\phi_3) + l_{\{4\}}(\phi_3) = -(l_{\{1\}}(\phi_3) + l_{\{3\}}(\phi_3)). \quad (37)$$

It follows that

$$|l_{\{1\}}(\phi_3) + l_{\{3\}}(\phi_3)| \tag{38}$$

$$= |H(A_1)_{\phi_3} - H(A_2)_{\phi_3} + H(A_3)_{\phi_3} - H(A_4)_{\phi_3}| \tag{39}$$

$$= 2H(A_1)_{\phi_1} \tag{40}$$

is a nonzero lower bound on the OEC of rotating ϕ_3 under the cycle entanglement allocation. However, in the case of the complete entanglement allocation, we obtain $e_{\text{opt}}(\phi_3) = 0$, as explained in Remark 9.

On this account, the case of the initial state ϕ_3 tells us that the use of the complete entanglement allocation can give a smaller total entanglement rate than that of the cycle entanglement allocation. This justifies that we consider the complete entanglement allocation rather than cyclic entanglement allocation in the definition of the QSR task.

V. CONDITIONS

In this section, we present a sufficient condition on positive OECs and a necessary condition on zero achievable total entanglement rates.

A. Condition on positive optimal entanglement cost

We provide a sufficient condition on positive OECs of the QSR task. When $M = 2$, the QSR task is nothing but the QSE task, and we can find out a condition by using results on the QSE task presented in Refs. [10,12]. That is, if $H(A_1)_{\psi} \neq H(A_2)_{\psi}$ for the initial state $|\psi\rangle_{A_1A_2E}$, then the OEC of the QSE task is positive, i.e., $e_{\text{opt}}(\psi) > 0$. So, one may naturally guess a generalized sufficient condition with respect to the initial state $|\psi\rangle_{AE}$ on $A = A_1A_2 \cdots A_M$ as follows: If there exist some $i, j \in [M]$ such that

$$H(A_i)_{\psi} \neq H(A_j)_{\psi}, \tag{41}$$

then $e_{\text{opt}}(\psi) > 0$.

However, this guess is not the case. Let us consider the initial state ϕ_3 in Eq. (34). Then, it is satisfied that $H(A_1)_{\phi_3} >$

$$\frac{1}{\alpha_M} \left(\beta_M l_{\{i,j\}}(\psi) + \gamma_M \sum_{\substack{s \in \{i,j\} \\ t \in [M] \setminus \{i,j\}}} l_{\{s,t\}}(\psi) - 2 \sum_{\substack{s,t \in [M] \setminus \{i,j\} \\ s < t}} l_{\{s,t\}}(\psi) \right), \tag{45}$$

where $l_{\{i\}}$ and $l_{\{i,j\}}$ are defined in Eq. (17), $\alpha_M = 2(M - 2)(M - 4)$, $\beta_M = 2 - (M - 4)^2$, and $\gamma_M = M - 4$.

The main idea of the proof for Theorem 13 is to construct a system of linear equations obtained by regarding segment entanglement rates as its unknowns and to solve it. We refer the reader to Appendix E for the proof of Theorem 13.

Remark 14. The meaning of Theorem 13 is that if there exist two sequences $\{\mathcal{R}_n\}_{n \in \mathbb{N}}$ and $\{\mathcal{R}'_n\}_{n \in \mathbb{N}}$ of QSR protocols for the same initial state $|\psi\rangle_{AE}$ whose achievable total entanglement rates are zero, then their segment entanglement rates are the same, i.e.,

$$e_{i,j}(\psi, \{\mathcal{R}_n\}) = e_{i,j}(\psi, \{\mathcal{R}'_n\}) \tag{46}$$

$0 = H(A_2)_{\phi_3}$, but $e_{\text{opt}}(\phi_3) = 0$ as explained in Remark 9. Interestingly, the above condition can be corrected in terms of quantum conditional entropies.

Theorem 11. Let $|\psi\rangle_{AE}$ be the initial state for the QSR task with $A = A_1A_2 \cdots A_M$. If there exist some $i, j \in [M]$ such that

$$H(E|A_i)_{\psi} \neq H(E|A_j)_{\psi}, \tag{42}$$

then $e_{\text{opt}}(\psi) > 0$.

The proof of Theorem 11 can be found in Appendix D.

Remark 12. The converse of Theorem 11 does not necessarily hold. Consider the initial state

$$|\phi_4\rangle_{AE} = \bigotimes_{i=1}^M |\varphi\rangle_{A_iE_i}, \tag{43}$$

where $E = E_1E_2 \cdots E_M$ and $|\varphi\rangle$ is any pure bipartite entangled state. Then we know that the OEC for rotating ϕ_4 is positive from the lower bound in Eq. (20), but the condition in Theorem 11 does not hold.

B. Condition on zero achievable total entanglement rate

We now present the following theorem providing a necessary condition on zero achievable total entanglement rates for the QSR task.

Theorem 13. Let $|\psi\rangle_{AE}$ be the initial state of the QSR task with $A = A_1A_2 \cdots A_M$, and let $\{\mathcal{R}_n\}_{n \in \mathbb{N}}$ be a sequence of QSR protocols \mathcal{R}_n of $\psi^{\otimes n}$ with error ε_n whose total entanglement rate r is achievable. If $r = 0$, then the segment entanglement rates $e_{i,j}(\psi, \{\mathcal{R}_n\})$ for $i \neq j$ are determined as follows:

(i) If $M = 3$, $e_{i,j}(\psi, \{\mathcal{R}_n\}) = -l_{\{i,j\}}(\psi)$.

(ii) If $M = 4$,

$$e_{i,j}(\psi, \{\mathcal{R}_n\}) = \frac{1}{2}(l_{\{i\}}(\psi) + l_{\{j\}}(\psi) - l_{\{i,j\}}(\psi)). \tag{44}$$

(iii) If $M > 4$, $e_{i,j}(\psi, \{\mathcal{R}_n\})$ is represented as

for each $i \neq j$. This implies that, when an achievable total entanglement rate of the QSR task is zero, for each $i \neq j$, all possible segment entanglement rates $e_{i,j}$ between the i th user and the j th user are uniquely determined as the same value, even though there may not be a unique optimal strategy for the QSR task.

Remark 15. To evaluate the segment entanglement rates presented in Theorem 13, we need to evaluate two quantities $l_{\{i\}}(\psi)$ and $l_{\{i,j\}}(\psi)$. In general, it is difficult to calculate these quantities with respect to the initial state $|\psi\rangle_{AE}$, since they are optimized over all isometries U from E to $V \otimes W$, where V and W are any quantum systems. However, for initial states

$|\psi\rangle_A$ without the environment system E , it is possible to compute them as follows:

$$l_{(i)}(\psi_A) = H(A_{i-1})_{\psi_A} - H(A_i)_{\psi_A}, \quad (47)$$

$$l_{(i,j)}(\psi_A) = H(A_{i-1}A_{j-1})_{\psi_A} - H(A_iA_j)_{\psi_A}. \quad (48)$$

We will see that these computable quantities play a crucial role in proving Proposition 16 in the next section.

VI. DIFFERENCE BETWEEN QUANTUM STATE ROTATION AND QUANTUM STATE EXCHANGE

In this section, we show that a property of the QSE task [10] does not hold in the QSR task. This shows the difference between the QSE task and the QSR task.

In the QSE task, the initial state $|\psi\rangle_{A_1A_2}$ without the environment system E can be exactly exchanged without consuming any entanglement resources via local unitary operations. So, for any initial state $|\psi\rangle_{A_1A_2}$, there exists a sequence of QSE protocols for $|\psi\rangle_{A_1A_2}$ whose achievable (total) entanglement rate is zero. Thus, the OEC for the QSE task of $|\psi\rangle_{A_1A_2}$ is always zero.

How about the QSR task of M users ($M \geq 3$)? That is, for any initial state $|\psi\rangle_A$ with $A = A_1A_2 \cdots A_M$, is there a sequence of QSR protocols whose achievable total entanglement rate is zero? In the cases of $M = 3, 4, 5$, we have not found answers to the above question. However, if $M \geq 6$, we can find some initial states that cannot be rotated at zero achievable total entanglement rate.

Proposition 16. For each $M \geq 6$, there exists an initial state $|\psi\rangle_A$ of the QSR task whose achievable total entanglement rates r cannot be zero, i.e., $r > 0$, where $A = A_1A_2 \cdots A_M$.

Before proving Proposition 16, let us consider a three-user (TU) task different from the QSR task. In the TU task, three users, Alice, Bob, and Charlie, share two Greenberger-Horne-Zeilinger (GHZ) states [17], and they transform the GHZ states into three ebits symmetrically shared among the three users, where the states are defined as

$$|\text{GHZ}\rangle = \frac{1}{\sqrt{2}}(|000\rangle + |111\rangle), \quad (49)$$

$$|\text{ebit}\rangle = \frac{1}{\sqrt{2}}(|00\rangle + |11\rangle). \quad (50)$$

It turns out that, by using LOCC, it is impossible to perform the TU task under the exact and asymptotic scenarios [18,19].

To prove Proposition 16, we further show that, even considering the catalytic use of entanglement resources among them, it is impossible to carry out the TU task under the asymptotic scenario. To be specific, assume that Alice, Bob, and Charlie of the TU task have quantum systems $A_iA'_i$, $B_iB'_i$, and $C_iC'_i$ with $i = 1, 2$, respectively. Let $|\phi\rangle$ and $|\phi_f\rangle$ be the initial and final states of the TU task given by

$$|\phi\rangle = |\text{GHZ}\rangle_{A_1B_1C_1} \otimes |\text{GHZ}\rangle_{A_2B_2C_2}, \quad (51)$$

$$|\phi_f\rangle = |\text{ebit}\rangle_{A'_1B'_2} \otimes |\text{ebit}\rangle_{B'_1C'_2} \otimes |\text{ebit}\rangle_{C'_1A'_2}. \quad (52)$$

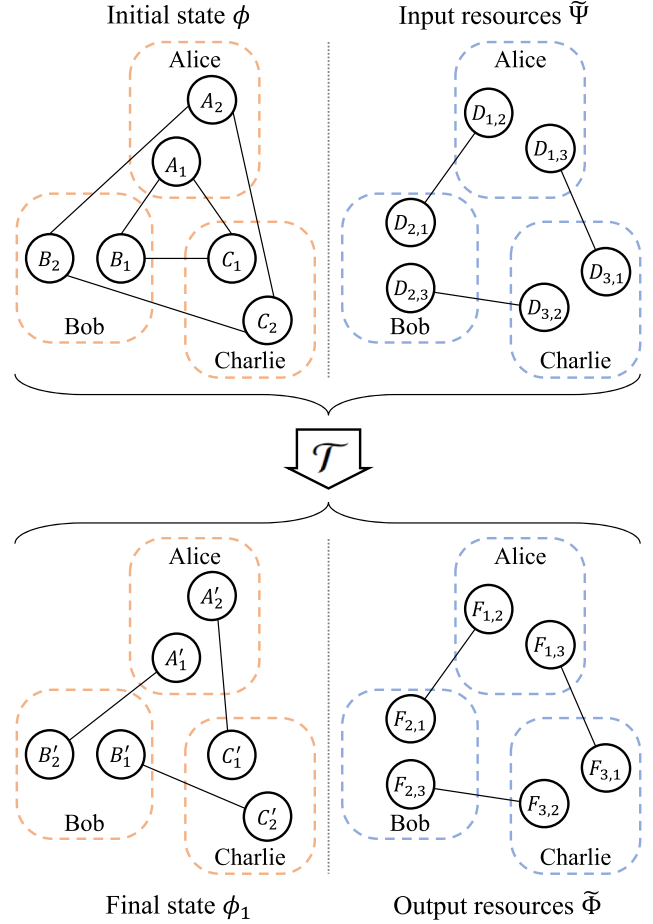

FIG. 6. Illustration for the three-user task of Alice, Bob, and Charlie: Circles indicate quantum systems for the task, and correlations among the quantum systems are represented by lines connecting them. In this task, the initial state ϕ and the final state ϕ_f consist of two GHZ states and three ebits, respectively. On the left side of the illustration, a GHZ state (an ebit) is represented as three (two) circles connected by lines. The aim of this task is to transform ϕ into ϕ_f . To perform the task, they apply LOCC \mathcal{T} to the initial state ϕ and input entanglement resources $\tilde{\Psi}$. After the task, they can gain output entanglement resources $\tilde{\Phi}$ from the task.

Then a quantum channel

$$\mathcal{T} : \mathcal{L}\left(\bigotimes_{i=1}^2 A_i B_i C_i \otimes D\right) \longrightarrow \mathcal{L}\left(\bigotimes_{i=1}^2 A'_i B'_i C'_i \otimes F\right) \quad (53)$$

is called the TU protocol of the initial state ϕ with error ε , if it is performed by LOCC among the three users and satisfies $\|\mathcal{T}(\phi \otimes \tilde{\Psi}) - \phi_f \otimes \tilde{\Phi}\|_1 \leq \varepsilon$, where D and F are multipartite quantum systems with $D = D_{1,2}D_{1,3}D_{2,1}D_{2,3}D_{3,1}D_{3,2}$ and $F = F_{1,2}F_{1,3}F_{2,1}F_{2,3}F_{3,1}F_{3,2}$, and $\tilde{\Psi}$ and $\tilde{\Phi}$ are entanglement resources on D and F for the complete entanglement allocation. We present an illustration for the TU task in Fig. 6.

We provide the following lemma whose proof is presented in Appendix F.

Lemma 17. Let $|\phi\rangle$ be the initial state of the TU task. Then there is no sequence $\{\mathcal{T}_n\}_{n \in \mathbb{N}}$ of LOCC \mathcal{T}_n of $\phi^{\otimes n}$ with error ε_n such that $e_{i,j}(\phi, \{\mathcal{T}_n\}) = 0$ for each $i \neq j$ and $\lim_{n \rightarrow \infty} \varepsilon_n = 0$.

In Lemma 17, the catalytic use of entanglement resources is described in the following sense: While three users are free to consume and gain the entanglement resources in each protocol \mathcal{T}_n , the amount of entanglement consumed by every pair of the users is asymptotically equal to that of entanglement gained between them; i.e., the segment entanglement rate $e_{i,j}(\phi, \{\mathcal{T}_n\})$ is zero, for each $i \neq j$.

Proof of Proposition 16. As described in Fig. 7(a), we construct an initial state $|\phi_5\rangle_A$ of the QSR task on the system $A = A_1 A_2 \cdots A_M$ with $M \geq 6$ as follows:

$$|\phi_5\rangle_A = |\text{GHZ}\rangle_{A_{1,1}A_{3,1}A_{5,1}} \otimes |\text{GHZ}\rangle_{A_{1,2}A_{3,2}A_{5,2}} \otimes \bigotimes_{i \in [M] \setminus \{1,3,5\}} |\varphi_i\rangle_{A_i}, \quad (54)$$

where $A_i = A_{i,1}A_{i,2}$ for $i = 1, 3, 5$, and $|\varphi_i\rangle$ is any pure quantum state. The final state corresponding to ϕ_5 is also presented in Fig. 7(b).

Suppose that there is a sequence $\{\mathcal{R}_n\}_{n \in \mathbb{N}}$ of QSR protocols \mathcal{R}_n of $\phi_5^{\otimes n}$ whose achievable total entanglement rate is zero. From Theorem 13, we obtain exact values of the segment entanglement rates $e_{i,j}(\phi_5, \{\mathcal{R}_n\})$ for $i \neq j$ as follows:

$$e_{i,j}(\phi_5, \{\mathcal{R}_n\}) = \begin{cases} 1 & \text{if } i, j \in \{2, 4, 6\} \\ -1 & \text{if } i, j \in \{1, 3, 5\} \\ 0 & \text{otherwise.} \end{cases} \quad (55)$$

Illustrations for quantum systems of entanglement resources giving nonzero segment entanglement rates are provided in Fig. 8.

The sequence $\{\mathcal{R}_n\}_{n \in \mathbb{N}}$ and its segment entanglement rates $e_{i,j}$ in Eq. (55) imply that it is possible to carry out the TU task by means of LOCC assisted by the catalytic use of entanglement under the asymptotic scenario. To be specific, recall that each \mathcal{R}_n is LOCC protocol transforming the initial state $\phi_5^{\otimes n}$ and the input entanglement resources Ψ_n into the final state $\phi_f^{\otimes n}$ and the output entanglement resources Φ_n with error ε_n , where ϕ_f is the final state of the QSR task corresponding to the initial state ϕ_5 . Note that, in Eq. (55), the zero segment entanglement rate $e_{i,j}$ means that the i th user and the j th user catalytically use entanglement resources in the asymptotic scenario. Thus, the sequence $\{\mathcal{R}_n\}_{n \in \mathbb{N}}$ of the QSR protocols can be considered as a sequence of LOCC protocols assisted by the catalytic use of entanglement, which asymptotically transforms an initial state

$$|\eta\rangle = |\text{GHZ}\rangle_{A_{1,1}A_{3,1}A_{5,1}} \otimes |\text{GHZ}\rangle_{A_{1,2}A_{3,2}A_{5,2}} \otimes \bigotimes_{i \in [M] \setminus \{1,3,5\}} |\varphi_i\rangle_{A_i} \otimes |\text{ebit}\rangle_{B_{2,4}B_{4,2}} \otimes |\text{ebit}\rangle_{B_{4,6}B_{6,4}} \otimes |\text{ebit}\rangle_{B_{6,2}B_{2,6}} \quad (56)$$

into a final state

$$|\eta_f\rangle = |\text{GHZ}\rangle_{A'_{1,1}A'_{3,1}A'_{5,1}} \otimes |\text{GHZ}\rangle_{A'_{1,2}A'_{3,2}A'_{5,2}} \otimes \bigotimes_{i \in [M] \setminus \{1,3,5\}} |\varphi_i\rangle_{A'_i} \otimes |\text{ebit}\rangle_{C_{1,3}C_{3,1}} \otimes |\text{ebit}\rangle_{C_{3,5}C_{5,3}} \otimes |\text{ebit}\rangle_{C_{5,1}C_{1,5}}. \quad (57)$$

In this case, if the first user has all systems of the others except for the third user and the fifth user, and the first user play the roles of the rest except for the third user and the fifth user, then the first user can locally prepare the three ebits and the pure quantum states φ_i with $i \in [M] \setminus \{1, 3, 5\}$ of the initial state η and the two GHZ states of the final state η_f , and the third user and the fifth user can locally prepare the pure quantum

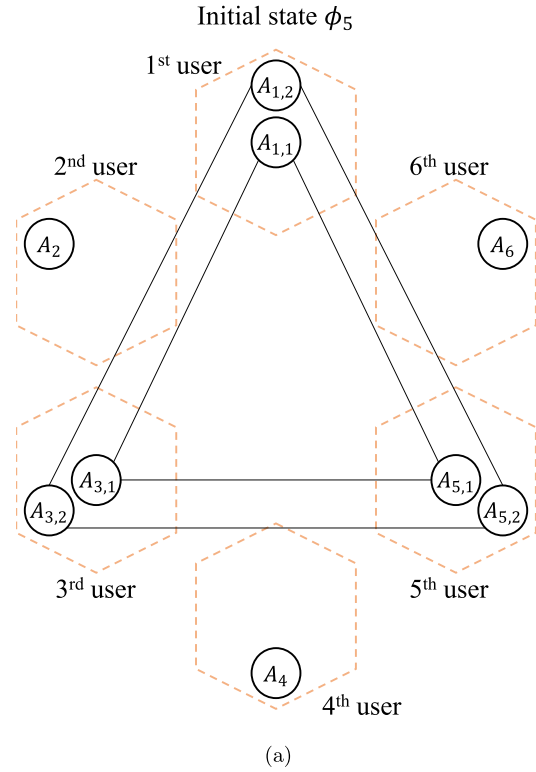

(a)

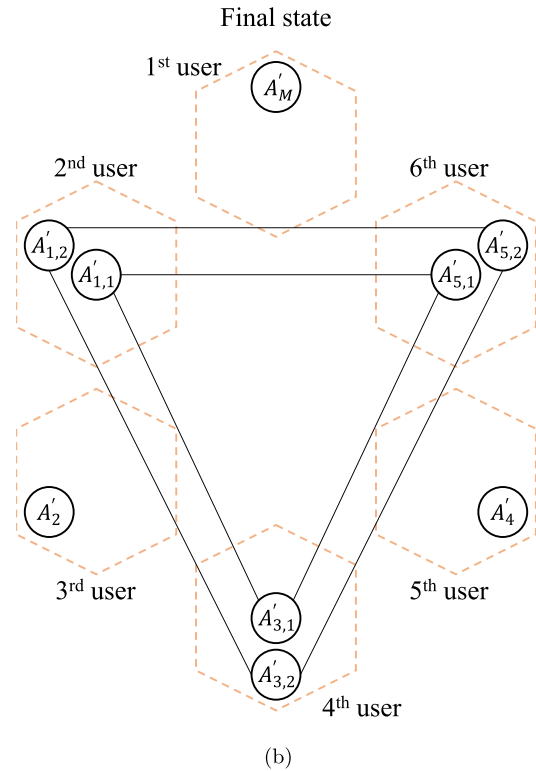

(b)

FIG. 7. (a) Initial state ϕ_5 in Eq. (54) shared over M users for $M \geq 6$. (b) Final state obtained by rotating the initial state. In each illustration, circles indicate quantum systems for the quantum state rotation task, and, for each $i \geq 7$, the i th user and his or her quantum systems are not explicitly illustrated. A GHZ state is represented as three circles connected by lines.

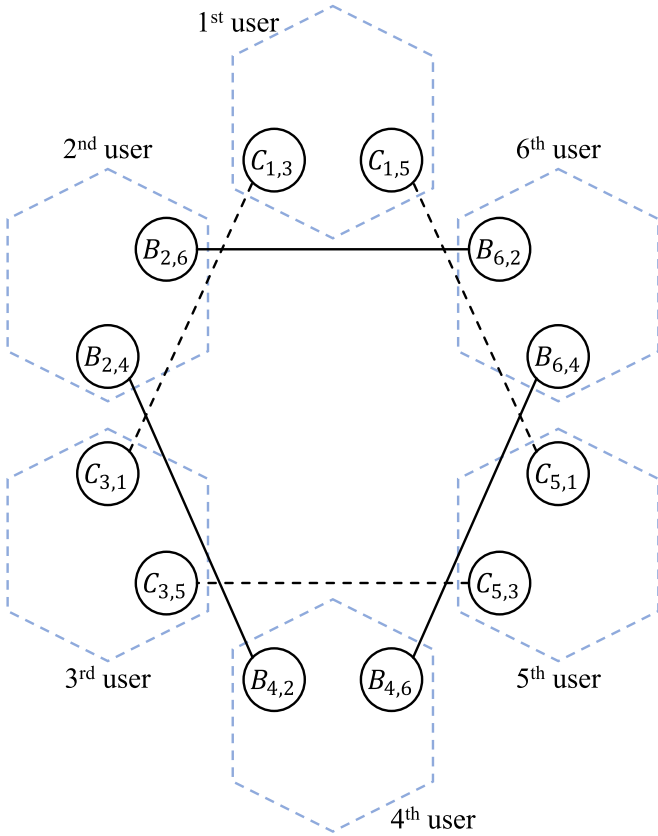

FIG. 8. Systems of entanglement resources giving positive or negative segment entanglement rates: Circles indicate quantum systems for entanglement resources, and, for each $i \geq 7$, the i th user and his or her quantum systems are not explicitly illustrated. If we assume that the initial state ϕ_5 in Eq. (54) can be rotated by a sequence $\{\mathcal{R}_n\}_{n \in \mathbb{N}}$ of QSR protocols whose achievable total entanglement rate is zero, then Theorem 13 implies that all segment entanglement rates have one of three values 1, 0, and -1 , as shown in Eq. (55). In this illustration, consumed (generated) entanglement resources corresponding to positive (negative) segment entanglement rates are described as circles connected by straight (dashed) lines. Entanglement resources for zero segment entanglement rates are not explicitly illustrated.

states ϕ_2 and ϕ_4 , respectively. It follows that there exists a sequence of LOCC protocols assisted by the catalytic use of entanglement, which asymptotically transforms a quantum state

$$|\text{GHZ}\rangle_{A_{1,1}A_{3,1}A_{5,1}} \otimes |\text{GHZ}\rangle_{A_{1,2}A_{3,2}A_{5,2}} \quad (58)$$

into a quantum state

$$|\text{ebit}\rangle_{C_{1,3}C_{3,1}} \otimes |\text{ebit}\rangle_{C_{3,5}C_{5,3}} \otimes |\text{ebit}\rangle_{C_{5,1}C_{1,5}}. \quad (59)$$

This means that two GHZ states shared by the first user, the third user, and the fifth user are transformed into the three ebits symmetrically shared among the three users by means of LOCC and the catalytic use of entanglement resources under the asymptotic scenario. However, this contradicts Lemma 17. Hence, the achievable total entanglement rate r is positive. ■

We remark that it is not sufficient to consider initial states similar to the state ϕ_5 in Eq. (54) in order to prove Proposition 16 with respect to $M = 3, 4, 5$. For example, consider the

initial state

$$|\phi_6\rangle_A = |\text{GHZ}\rangle_{A_{1,1}A_{2,1}A_{3,1}} \otimes |\text{GHZ}\rangle_{A_{1,2}A_{2,2}A_{3,2}} \otimes |\varphi\rangle_{A_4}, \quad (60)$$

where $A_i = A_{i,1}A_{i,2}$ for $i = 1, 2, 3$, and $|\varphi\rangle$ is any pure quantum state. If there exists a sequence $\{\mathcal{R}_n\}$ of QSR protocols for ϕ_6 whose achievable total entanglement rate is zero, then Theorem 13 tells us that its segment entanglement rates are determined as

$$e_{1,2}(\phi_6, \{\mathcal{R}_n\}) = e_{1,3}(\phi_6, \{\mathcal{R}_n\}) = -1, \quad (61)$$

$$e_{1,4}(\phi_6, \{\mathcal{R}_n\}) = e_{2,3}(\phi_6, \{\mathcal{R}_n\}) = 0, \quad (62)$$

$$e_{2,4}(\phi_6, \{\mathcal{R}_n\}) = e_{3,4}(\phi_6, \{\mathcal{R}_n\}) = 1. \quad (63)$$

To the best of our knowledge, whether such a sequence exists or not is unknown. On this account, it is hard to prove Proposition 16 for $M = 3, 4, 5$, as long as we stick to initial states consisting of the two GHZ states.

VII. EXAMPLES

A. SWAP-invariant initial states

In this section, we see that reduction of the number of users in the QSR task does not necessarily reduce the OEC of the task.

The initial state $|\psi\rangle_{A_1A_2A_3A_4E}$ of the QSR task is said to be SWAP invariant on systems A_2 and A_3 , if it satisfies

$$(\text{SWAP}_{A_2 \leftrightarrow A_3})(\psi) = \psi, \quad (64)$$

where $\text{SWAP}_{X \leftrightarrow Y}$ is a quantum channel swapping quantum states in quantum systems X and Y . Let us consider the QSR task of the SWAP-invariant initial state $|\psi\rangle_{A_1A_2A_3A_4E}$. We provide illustrations of the SWAP-invariant initial state and its final state in Figs. 9(a) and 9(b), respectively. From the viewpoint of the third user, the part A'_2 of the final state ψ_f is identical to the part A_3 of the initial state ψ . So, it is possible to exclude the third user to carry out the QSR task of the four users, and so the third user does nothing, since this task can be done by the second user directly transmitting his or her quantum state to the fourth user, as described in Fig. 9(c). In other words, the original QSR task of the four users can be replaced by the QSR task of the first user, the second user, and the fourth user for the same initial state.

Let $e_{\text{opt}}^{(3)}(\psi)$ and $e_{\text{opt}}^{(4)}(\psi)$ be the OECs for the QSR tasks of the initial state $|\psi\rangle_{A_1A_2A_3A_4E}$ performed by the three users and the four users, respectively. In this case, are two OECs $e_{\text{opt}}^{(3)}(\psi)$ and $e_{\text{opt}}^{(4)}(\psi)$ equal? One may guess that $e_{\text{opt}}^{(3)}(\psi) \leq e_{\text{opt}}^{(4)}(\psi)$ holds in general, since the part A_3 does not need to be transmitted during the second.

However, this is not the case. Consider the SWAP-invariant initial state

$$|\phi_7\rangle_{A_1A_2A_3A_4} = |\varphi_1\rangle_{A_1} \otimes |\text{ebit}\rangle_{A_2A_3} \otimes |\varphi_2\rangle_{A_4}, \quad (65)$$

where E is regarded as a one-dimensional system, $|\varphi_1\rangle$ and $|\varphi_2\rangle$ are any pure quantum states, and $|\text{ebit}\rangle$ is presented in Eq. (50).

If the first user, the second user, and the fourth user rotate the initial state ϕ_7 without the third user, then this QSR task is nothing but Schumacher compression [9,16] in which the

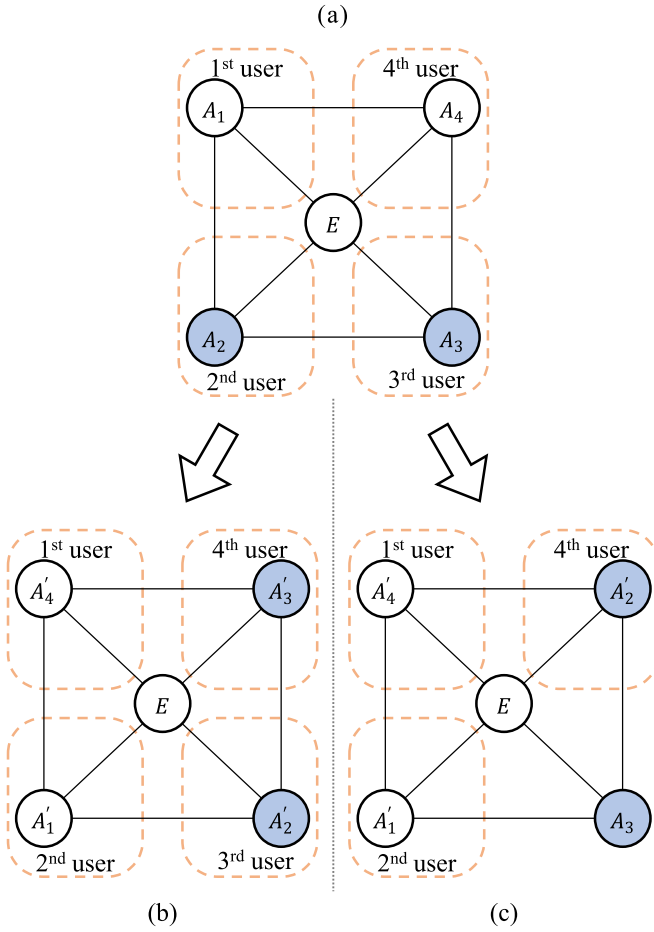

FIG. 9. In each illustration, circles indicate quantum systems for the initial and final states, and two blue circles represent symmetric parts. (a) Initial state $|\psi\rangle_{A_1 A_2 A_3 A_4 E}$ of the quantum state rotation task for four users: The initial state is SWAP invariant on systems A_2 and A_3 . (b) Final state rotated by all users. (c) Final state rotated by the first user, the second user, and the fourth user: Here, the quantum system A_3 is considered as a part of the environment.

part A_2 is transmitted to the fourth user by consuming ebits instead of qubit channels. This is because the quantum states φ_1 and φ_2 can be locally prepared by the second user and the first user, respectively, without consuming and gaining any entanglement resource. It turns out that the minimal amount of entanglement required for this Schumacher compression is $H(A_2)_{\phi_7}$, and Theorem 3 implies that $H(A_2)_{\phi_7}$ is a lower bound on the OEC of this QSR task of three users. Thus, we have $e_{\text{opt}}^{(3)}(\phi_7) = H(A_2)_{\phi_7}$.

On the other hand, in the QSR task of four users, the third user can locally prepare an ebit, and then the third user can share the ebit with the fourth user by using the Schumacher compression [9,16] and the quantum teleportation [1]. The amount of entanglement consumed in this transmission is $H(A_2)_{\phi_7}$. The second user and the third user can gain the same amount of entanglement by distilling the ebit on the systems A_2 and A_3 . Lastly, without any entanglement resource, the first user and the second user locally prepare φ_2 and φ_1 , respectively. In this way, the initial state ϕ_7 is rotated, and the

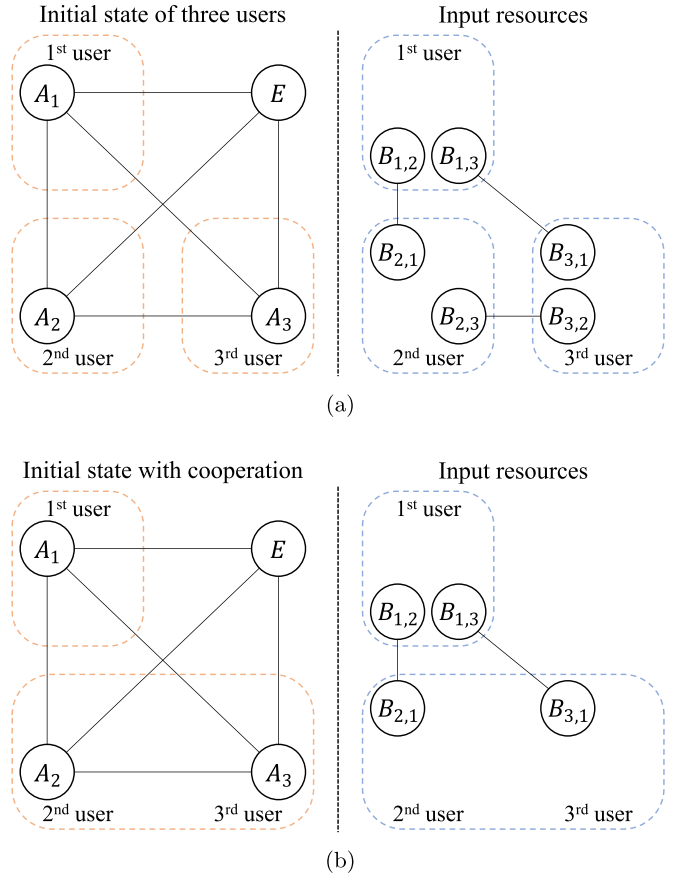

FIG. 10. (a) Initial state and input entanglement resources for the quantum state rotation task of three users. (b) Initial state and input entanglement resources when the second user and the third user cooperate: To cooperate, they gathered in the same laboratory, and so an entangled state in the systems $B_{2,3}$ and $B_{3,2}$ is not considered a nonlocal resource. In the second illustration, these systems are not described.

achievable total entanglement rate becomes zero in this case. The non-negativity of the OEC implies $e_{\text{opt}}^{(4)}(\phi_7) = 0$.

Therefore, we obtain that $e_{\text{opt}}^{(3)}(\phi_7) > e_{\text{opt}}^{(4)}(\phi_7)$ holds for the SWAP-invariant initial state ϕ_7 . This means that even though the third user does not have to participate in the QSR task, helping the remaining users to achieve the task can reduce the OEC.

B. Quantum state rotation with cooperation

In this section, we answer the following question: If some of the users are allowed not only LOCC but nonlocal (global) operations on their shared quantum systems, can they perform the QSR task at a smaller OEC?

We consider the QSR task of $|\psi\rangle_{A_1 A_2 A_3 E}$ performed by three users, as shown in Fig. 10(a), and we modify this QSR task by assuming that the second user and the third user are in the same laboratory in order to cooperate, as depicted in Fig. 10(b). In this case, the second user and the third user can apply any quantum operations to their quantum states in the laboratory, but pure maximally entangled states shared by the second user and the third user are not considered nonlocal

resources in this modified task, since the entangled states can be locally prepared in their laboratory. On this account, while the three users in Fig. 10(b) can make use of any QSR protocol of $|\psi\rangle_{A_1A_2A_3E}$ in Fig. 10(a), it is hard to guess the minimal amount of entanglement consumed by two laboratories in the modified task.

Under this setting, one may guess that the OEC of the modified task is less than or equal to that of the original one. However, the initial state

$$|\phi_8\rangle_{A_1A_2A_3} = |\varphi_1\rangle_{A_1} \otimes |\varphi_2\rangle_{A_2A_3} \quad (66)$$

shows that such a guess is wrong, where E is regarded as a one-dimensional system, $|\varphi_1\rangle$ is any pure quantum state, and $|\varphi_2\rangle$ is any pure entangled state. In this case, the initial state ϕ_8 can be rotated by three users with a zero achievable total entanglement rate as follows: The pure quantum state $|\varphi_1\rangle$ is prepared by the second user, and the first user and the third user can share the pure quantum state $|\varphi_2\rangle$ by using Schumacher compression [9,16] together with the quantum teleportation [1]. The amount of entanglement consumed in this transmission is $H(A_2)_{\phi_8}$. The second user and the third user can gain the same amount of entanglement by applying entanglement distillation [13–15] to φ_2 on the systems A_2A_3 . Thus, the OEC is zero when the QSR task is performed without any cooperation.

On the other hand, in the modified task, the first user and the second (third) user cannot share the quantum state φ_2 without consuming any entanglement resources between two laboratories, since φ_2 is entangled. This means that the OEC of the modified task is positive. Therefore, from the initial state ϕ_8 , we know that the OEC for the original task without any cooperation can be less than that of the modified task in which some of the users cooperate. This is because one does not take into account gain as well as consumption of entanglement resources between them when computing the OEC of the modified task with the cooperation of the second user and the third user.

VIII. CONCLUSION

In this work, we have introduced the QSR task in which the M users circularly transfer their respective quantum states via entanglement-assisted LOCC. We have considered the QSR as a fundamental quantum communication task for M users and have investigated the minimal amount of entanglement consumed among the users under the asymptotic scenario. For this investigation, we have formally formulated the QSR protocol, the achievable total entanglement rate, and the OEC. We have derived lower and upper bounds on the OEC, and have presented conditions on zero OECs and zero achievable total entanglement rates.

The QSR task includes the QSE task [10–12] as a special case, in which two users, Alice and Bob, exchange their respective quantum states via entanglement-assisted LOCC. However, the QSR task is not a direct generalization of the QSE task. That is, we have shown that there is a unique property of the QSR task not appearing in QSE tasks for two users: Not all initial states without the environment system

can be rotated without consuming any entanglement, while such states can be exchanged at zero entanglement cost via local unitary operations. We have also considered two specific settings of QSR tasks. In the first setting, some users do not have to participate in the task. In the second, some of the users can cooperate by using nonlocal operations. For some initial states, we have shown that the OEC for the original QSR task can be smaller than those for each setting.

While the lower bound l presented in Eq. (20) is helpful to evaluate the OEC, it becomes zero for initial states without the environment system E . This means that it is not straightforward to determine whether the OECs for such initial states are zero or not, unless we can explicitly construct an optimal QSR protocol. This is the main reason why we used the result of Theorem 13 that the segment entanglement rates are determined in terms of the von Neumann entropies of the initial state, in order to prove Proposition 16 instead of the lower bound l . On this account, finding tighter lower bounds can be a meaningful future work.

As potential applications of our work, the QSR task can serve as one of the fundamental subroutines in distributed quantum computing [20,21] and quantum networks [22,23], since they usually involve more than two users. In addition, the QSR task can be used as a subtask of more general quantum communication tasks. For example, let σ be a permutation on $[M]$; then we can devise a new quantum communication task for M users in which the i th user transmits his or her quantum state to the $\sigma(i)$ th user by means of entanglement-assisted LOCC. We call this task *quantum state permutation*. It is a well-known fact that any permutation on a finite set has a unique cycle decomposition; i.e., the permutation is expressed as a product of disjoint cycles. So, the quantum state permutation task with respect to σ can be decomposed as QSR subtasks, since the QSR tasks intuitively correspond to disjoint cycles. In this situation, our results for the QSR task can be useful tools to investigate the OEC for the quantum state permutation task.

ACKNOWLEDGMENTS

This research was supported by the Basic Science Research Program through the National Research Foundation of Korea (NRF) funded by the Ministry of Education (Grants No. NRF-2019R1A6A3A01092426 and No. NRF-2020R1I1A1A01058364). H.Y. acknowledges CREST (Japan Science and Technology Agency) JPMJCR1671, Cross-ministerial Strategic Innovation Promotion Program (SIP) [Council for Science, Technology and Innovation (CSTI)], and JSPS Overseas Research Fellowships. S.L. acknowledges support from the Basic Science Research Program through the National Research Foundation of Korea funded by the Ministry of Science and ICT (Grant No. NRF-2019R1A2C1006337) and the Ministry of Science and ICT, Korea, under the Information Technology Research Center support program (Grant No. IITP-2021-2018-0-01402) supervised by the Institute for Information and Communications Technology Promotion.

APPENDIX A: PROOF OF LEMMA 2

In this Appendix, we prove Lemma 2 in the main text. If a protocol \mathcal{R} in Eq. (8) satisfies $(\mathcal{R} \otimes \text{id}_{\mathcal{L}(E)})(\psi \otimes \tilde{\Psi}) = \psi_f \otimes \tilde{\Phi}$, then \mathcal{R} is said to be *exact*. The case regarding only exact QSR protocols is called an *exact scenario*.

To express two sets of the M users, we make use of a partition of the set $[M]$. Let $\{P, P^c\}$ be a partition of the set $[M]$, where P is any nonempty proper subset of $[M]$, and P^c is the complement of P , i.e., $P^c = [M] \setminus P$. If we interpret an element i of the set $[M]$ as the i th user of the QSR task, then we can divide the M users into two disjoint subsets P and P^c via the partition $\{P, P^c\}$.

For an exact QSR protocol \mathcal{R} of ψ , we define the *bipartite entanglement difference* $d_P(\psi, \mathcal{R})$ for a partition $\{P, P^c\}$ as

$$d_P(\psi, \mathcal{R}) = \sum_{i \in P} \sum_{j \in P^c} [\log d_{B_{i,j}} - \log d_{C_{i,j}}], \quad (\text{A1})$$

where $d_{B_{i,j}}$ ($d_{C_{i,j}}$) indicates the Schmidt rank of the entanglement resource $\Psi_{i,j}$ ($\Phi_{i,j}$) shared by the i th user and the j th user before (after) performing the QSR protocol \mathcal{R} . The following proposition provides a lower bound on the bipartite entanglement difference for the QSR task of the initial state ψ .

Proposition 18. Let $|\psi\rangle_{AE}$ be the initial state of the QSR task. The bipartite entanglement difference $d_P(\psi, \mathcal{R})$ for a partition $\{P, P^c\}$ is lower bounded by

$$d_P(\psi, \mathcal{R}) \geq l_P(\psi) = \max_U \left\{ H \left(\bigotimes_{i \in P} A_{i-1} V \right)_{U|\psi} - H \left(\bigotimes_{i \in P} A_i V \right)_{U|\psi} \right\}, \quad (\text{A2})$$

where the maximum is taken over all isometries U from E to $V \otimes W$, V and W are any quantum systems, and $U|\psi\rangle$ is an abbreviation for $\mathbb{1}_A \otimes U|\psi\rangle$.

Proof. Let us consider an *R-assisted QSR* task whose idea comes from Refs. [10–12]. While the environment system E of the initial state $|\psi\rangle_{AE}$ is not owned by any users of the original QSR task, in the *R-assisted QSR* task, we additionally consider a referee who has the environment system E . In this task, the referee can assist M users as follows: The referee divides his part E of the initial state $|\psi\rangle_{AE}$ into two parts V and W . To be specific, the referee locally applies an isometry $U : E \rightarrow V \otimes W$ [9] to his quantum state on the quantum system E , and so the initial state $|\psi\rangle_{AE}$ becomes a quantum state $|\xi\rangle_{AVW}$ satisfying $\text{Tr}_E \psi = \text{Tr}_{VW} \xi$. The referee now transfers his quantum state on the system V (W) to one of the users belonging to the set P (P^c), so that the M users can share the quantum state $|\xi\rangle_{AVW}$.

After finishing the referee's assistance, M users rotate the quantum state $|\xi\rangle_{AVW}$ via entanglement-assisted LOCC, as in the original QSR. To be specific, the quantum systems V and W of the users are not rotated during the QSR task, while the user can use them as quantum side information, as in other quantum communication tasks [2,3,6–8,11,12]. In the following, we call such a protocol an *exact R-assisted QSR* protocol of the state $|\xi\rangle_{AVW}$, and it is denoted by \mathcal{A} . Since \mathcal{A} is LOCC among the M users, it is also LOCC between two disjoint subsets P and P^c of the users. By using the fact that the amount of entanglement between two sets P and P^c of the users cannot increase on average via LOCC [14], we obtain the inequality

$$H \left(\bigotimes_{i \in P} A_i V B_i \right)_{\xi \otimes \tilde{\Psi}} \geq H \left(\bigotimes_{i \in P} A'_{i-1} V C_i \right)_{\xi_f \otimes \tilde{\Phi}}. \quad (\text{A3})$$

By using the additivity of the von Neumann entropy [9], we obtain

$$H \left(\bigotimes_{i \in P} A_i V B_i \right)_{\xi \otimes \tilde{\Psi}} = H \left(\bigotimes_{i \in P} A_i V \right)_{\xi} + H \left(\bigotimes_{i \in P} B_i \right)_{\tilde{\Psi}}. \quad (\text{A4})$$

Recall that the quantum state $\tilde{\Psi}$ is defined as the tensor product of bipartite maximally entangled states as in Eq. (7), and the systems B_i are defined as in Eq. (10). The additivity of the von Neumann entropy [9] implies

$$H \left(\bigotimes_{i \in P} B_i \right)_{\tilde{\Psi}} = \sum_{\substack{i, j \in P \\ i < j}} H(B_{i,j} B_{j,i})_{\Psi_{i,j}} + \sum_{i \in P} \sum_{j \in P^c} H(B_{i,j})_{\Psi_{i,j}} = \sum_{i \in P} \sum_{j \in P^c} \log d_{B_{i,j}}. \quad (\text{A5})$$

Since $\Psi_{i,j}$ is a pure bipartite maximally entangled state on quantum systems $B_{i,j} B_{j,i}$ whose Schmidt rank is $d_{B_{i,j}}$, $H(B_{i,j} B_{j,i})_{\Psi_{i,j}} = 0$ and $H(B_{i,j})_{\Psi_{i,j}} = \log d_{B_{i,j}}$ hold for each $i \neq j$. The second equality in Eq. (A5) comes from this fact. So we obtain

$$H \left(\bigotimes_{i \in P} A_i B_i V \right)_{\xi \otimes \tilde{\Psi}} = H \left(\bigotimes_{i \in P} A_i V \right)_{\xi} + \sum_{i \in P} \sum_{j \in P^c} \log d_{B_{i,j}}. \quad (\text{A6})$$

By using the same method, we obtain

$$H \left(\bigotimes_{i \in P} A'_{i-1} C_i V \right)_{\xi_f \otimes \tilde{\Phi}} = H \left(\bigotimes_{i \in P} A'_{i-1} V \right)_{\xi_f} + \sum_{i \in P} \sum_{j \in P^c} \log d_{C_{i,j}}, \quad (\text{A7})$$

where $d_{C_{i,j}}$ is the Schmidt rank of the entanglement resource $\Phi_{i,j}$ on quantum systems $C_{i,j}C_{j,i}$. Consequently, the inequality in Eq. (A3) is rewritten as

$$\sum_{i \in P} \sum_{j \in P^c} [\log d_{B_{i,j}} - \log d_{C_{i,j}}] \geq H\left(\bigotimes_{i \in P} A'_{i-1} V\right)_{\xi_f} - H\left(\bigotimes_{i \in P} A_i V\right)_{\xi} = H\left(\bigotimes_{i \in P} A'_{i-1} V\right)_{U|\psi_f} - H\left(\bigotimes_{i \in P} A_i V\right)_{U|\psi}, \quad (\text{A8})$$

where $U|\psi_f\rangle$ and $U|\psi\rangle$ are abbreviations for $\mathbb{1}_A \otimes U|\psi_f\rangle$ and $\mathbb{1}_A \otimes U|\psi\rangle$, respectively. By the definition of the final state ψ_f , we obtain that

$$H\left(\bigotimes_{i \in P} A'_{i-1} V\right)_{U|\psi_f} = H\left(\bigotimes_{i \in P} A_{i-1} V\right)_{U|\psi} \quad (\text{A9})$$

holds. It follows that

$$d_P(\psi, \mathcal{A}) \geq H\left(\bigotimes_{i \in P} A_{i-1} V\right)_{U|\psi} - H\left(\bigotimes_{i \in P} A_i V\right)_{U|\psi}. \quad (\text{A10})$$

Note that the above inequality holds for any quantum systems V and W and any isometry $U : E \rightarrow V \otimes W$. We further note that any exact QSR protocol of $|\psi\rangle_{AE}$ is the special case of the exact R -assisted QSR protocol in which the referee does not assist the users. It follows that $d_P(\psi, \mathcal{R}) \geq l_P(\psi)$ holds. ■

Similarly to the bipartite entanglement difference, we define the *bipartite entanglement rate* $e_P(\psi, \{\mathcal{R}_n\})$ with respect to the partition $\{P, P^c\}$ of the set $[M]$ and the sequence $\{\mathcal{R}_n\}_{n \in \mathbb{N}}$ whose total entanglement rate is achievable as follows:

$$e_P(\psi, \{\mathcal{R}_n\}) = \sum_{i \in P} \sum_{j \in P^c} e_{i,j}(\psi, \{\mathcal{R}_n\}), \quad (\text{A11})$$

where the segment entanglement rate $e_{i,j}$ is defined in Eq. (11). To prove Lemma 2, we use the following lemma telling the continuity of the von Neumann entropy [9,24,25].

Lemma 19 (Fannes-Audenaert inequality [9]). Let ρ and σ be density operators in $\mathcal{D}(X)$, where X is a quantum system, and suppose that $\varepsilon := \frac{1}{2} \|\rho - \sigma\|_1$. Then the inequality $|H(\rho) - H(\sigma)| \leq \varepsilon \log[d_X - 1] + h(\varepsilon)$ holds, where $h(\cdot)$ is the binary entropy.

Proof of Lemma 2. We consider the R -assisted QSR task explained in the proof of Proposition 18. To be specific, for each n , we consider an R -assisted QSR protocol

$$\mathcal{A}_n : \mathcal{L}\left(\bigotimes_{i=1}^M A_i^{\otimes n} V^{\otimes n} W^{\otimes n} B_i^{(n)}\right) \longrightarrow \mathcal{L}\left(\bigotimes_{i=1}^M (A'_i)^{\otimes n} V^{\otimes n} W^{\otimes n} C_i^{(n)}\right) \quad (\text{A12})$$

of the quantum state $|\xi\rangle_{AVW}^{\otimes n}$ with error ε_n satisfying

$$\|\mathcal{A}_n(\xi^{\otimes n} \otimes \tilde{\Psi}_n) - \xi_f^{\otimes n} \otimes \tilde{\Phi}_n\|_1 \leq \varepsilon_n, \quad (\text{A13})$$

where quantum systems $B_i^{(n)}$ and $C_i^{(n)}$ are defined by

$$B_i^{(n)} = \bigotimes_{j \in [M] \setminus \{i\}} B_{i,j}^{(n)} \quad \text{and} \quad C_i^{(n)} = \bigotimes_{j \in [M] \setminus \{i\}} C_{i,j}^{(n)}, \quad (\text{A14})$$

and $\tilde{\Psi}_n$ and $\tilde{\Phi}_n$ are explained in Sec. II C. For each n , let T_n^{bef} and T_n^{aft} be total amounts of entanglement between two sets P and P^c of the users before and after performing the protocol \mathcal{A}_n , respectively. Since the amount of entanglement between the two sets of the users cannot increase on average via LOCC [14], we obtain that $T_n^{\text{bef}} \geq T_n^{\text{aft}}$ holds for each n . Note that the amounts of entanglement are represented as

$$T_n^{\text{bef}} = H\left(\bigotimes_{i \in P} A_i^{\otimes n} V^{\otimes n} B_i^{(n)}\right)_{\xi^{\otimes n} \otimes \tilde{\Psi}_n} = nH\left(\bigotimes_{i \in P} A_i V\right)_{\xi} + \sum_{i \in P} \sum_{j \in P^c} \log d_{B_{i,j}^{(n)}} \quad \text{and} \quad T_n^{\text{aft}} = H\left(\bigotimes_{i \in P} (A'_{i-1})^{\otimes n} V^{\otimes n} C_i^{(n)}\right)_{\mathcal{A}_n(\xi^{\otimes n} \otimes \tilde{\Psi}_n)}, \quad (\text{A15})$$

where T_n^{bef} is obtained by using the additivity of the von Neumann entropy [9]. By applying the monotonicity of the trace distance [9] to the inequality in Eq. (A13), we have

$$\varepsilon'_n := \frac{1}{2} \left\| \text{Tr}_{\bigotimes_{i \in P^c} (A'_{i-1})^{\otimes n} C_i^{(n)} W^{\otimes n}} \left[\mathcal{A}_n(\xi^{\otimes n} \otimes \tilde{\Psi}_n) \right] - \text{Tr}_{\bigotimes_{i \in P^c} (A'_{i-1})^{\otimes n} C_i^{(n)} W^{\otimes n}} \left[\xi_f^{\otimes n} \otimes \tilde{\Phi}_n \right] \right\|_1 \leq \varepsilon_n. \quad (\text{A16})$$

By applying Lemma 19 to the above inequality, we obtain the following inequalities:

$$\left| T_n^{\text{aft}} - H\left(\bigotimes_{i \in P} (A'_{i-1})^{\otimes n} V^{\otimes n} C_i^{(n)}\right)_{\xi_f^{\otimes n} \otimes \Phi_n} \right| \leq \varepsilon'_n \log(d_{\bigotimes_{i \in P} (A'_{i-1})^{\otimes n} C_i^{(n)} V^{\otimes n}} - 1) + h(\varepsilon'_n) \leq \varepsilon'_n \log(d_{\bigotimes_{i \in P} (A'_{i-1})^{\otimes n} C_i^{(n)} V^{\otimes n}}) + h(\varepsilon'_n) \quad (\text{A17})$$

$$\leq \varepsilon'_n \left(n \sum_{i \in P} \log d_{A'_{i-1}} + \sum_{i \in P} \log d_{C_i^{(n)}} + n \log d_V \right) + h(\varepsilon'_n). \quad (\text{A18})$$

The additivity of the von Neumann entropy [9] implies

$$H\left(\bigotimes_{i \in P} (A'_{i-1})^{\otimes n} V^{\otimes n} C_i^{(n)}\right)_{\xi_f^{\otimes n} \otimes \Phi} = nH\left(\bigotimes_{i \in P} A'_{i-1} V\right)_{\xi_f} + \sum_{i \in P} \sum_{j \in P^c} \log d_{C_{i,j}^{(n)}}. \quad (\text{A19})$$

Consequently, $T_n^{\text{bef}} \geq T_n^{\text{aft}}$ becomes

$$nH\left(\bigotimes_{i \in P} A_i V\right)_{\xi} + \sum_{i \in P} \sum_{j \in P^c} \log d_{B_{i,j}^{(n)}} \geq nH\left(\bigotimes_{i \in P} A'_{i-1} V\right)_{\xi_f} + \sum_{i \in P} \sum_{j \in P^c} \log d_{C_{i,j}^{(n)}} - \varepsilon'_n \left(n \sum_{i \in P} \log d_{A'_{i-1}} + \sum_{i \in P} \log d_{C_i^{(n)}} + n \log d_V \right) - h(\varepsilon'_n). \quad (\text{A20})$$

This implies that

$$\sum_{i \in P} \sum_{j \in P^c} \frac{1}{n} (\log d_{B_{i,j}^{(n)}} - \log d_{C_{i,j}^{(n)}}) \geq H\left(\bigotimes_{i \in P} A'_{i-1} V\right)_{\xi_f} - H\left(\bigotimes_{i \in P} A_i V\right)_{\xi} - \varepsilon'_n \left(\sum_{i \in P} \log d_{A'_{i-1}} + \frac{1}{n} \sum_{i \in P} \log d_{C_i^{(n)}} + \log d_V \right) - \frac{h(\varepsilon'_n)}{n}, \quad (\text{A21})$$

which holds for each n , and so we obtain that

$$\begin{aligned} e_P(\psi, \{\mathcal{A}_n\}) &\geq H\left(\bigotimes_{i \in P} A'_{i-1} V\right)_{\xi_f} - H\left(\bigotimes_{i \in P} A_i V\right)_{\xi} = H\left(\bigotimes_{i \in P} A'_{i-1} V\right)_{U|\psi_f} - H\left(\bigotimes_{i \in P} A_i V\right)_{U|\psi} \\ &= H\left(\bigotimes_{i \in P} A_{i-1} V\right)_{U|\psi} - H\left(\bigotimes_{i \in P} A_i V\right)_{U|\psi}. \end{aligned} \quad (\text{A22})$$

Here, $U|\psi_f$ and $U|\psi$ are abbreviations for $\mathbb{1}_A \otimes U|\psi_f$ and $\mathbb{1}_A \otimes U|\psi$, respectively, and the last equality comes from Eq. (A9). Thus, we have $e_P(\psi, \{\mathcal{R}_n\}) \geq l_P(\psi)$, since the quantum system V, W and the isometry U are arbitrary, and any sequence of QSR protocols is also a sequence of R -assisted QSR protocols. ■

From Proposition 18 and Lemma 2, we know that the lower bound l_P of the exact scenario is also a lower bound of the asymptotic scenario. In other words, we can easily obtain a lower bound of the bipartite entanglement rate by merely finding that of the bipartite entanglement difference in the exact scenario. Note that it is possible to apply this technique to other quantum communication tasks, such as the generalized quantum Slepian-Wolf [26] and the multipartite state merging [27], in which users perform the tasks via entanglement-assisted LOCC in the asymptotic scenario.

We remark that while the lower bound in Proposition 18 is presented in terms of the von Neumann entropy, this lower bound can be generalized by replacing the von Neumann entropy with the Rényi entropies [28] under the exact scenario, as in the one-shot quantum state exchange [12].

APPENDIX B: PROOF OF THEOREM 3

Let r be any achievable total entanglement rate for the initial state ψ . Then there is a sequence $\{\mathcal{R}_n\}_{n \in \mathbb{N}}$ of QSR protocols \mathcal{R}_n of $\psi^{\otimes n}$ with error ε_n such that $e_{i,j}(\psi, \{\mathcal{R}_n\})$ converges for any i, j , $e_{\text{tot}}(\psi, \{\mathcal{R}_n\}) = r$, and $\lim_{n \rightarrow \infty} \varepsilon_n = 0$. Since $l_{P_k} = l_{P_{M-k}}$ holds for any $k \in [M-1]$, we have $l_k(\psi) = l_{M-k}(\psi)$. So we will prove in the following that $l_k(\psi)$ is a lower bound on the OEC for $1 \leq k \leq \lfloor M/2 \rfloor$.

For a nonempty proper subset P of the set $[M]$, we defined a function $f_P : [M] \times [M] \rightarrow \{0, 1\}$ as follows:

$$f_P(i, j) = \begin{cases} 1 & \text{if } (i \in P, j \in P^c) \text{ or } (j \in P, i \in P^c) \\ 0 & \text{otherwise.} \end{cases} \quad (\text{B1})$$

Note that $f_P(j, i) = f_P(i, j)$ holds for each i, j , and the bipartite entanglement rate $e_P(\psi, \{\mathcal{R}_n\})$ is represented as

$$e_P(\psi, \{\mathcal{R}_n\}) = \sum_{\substack{i, j \in [M] \\ i < j}} f_P(i, j) e_{i,j}(\psi, \{\mathcal{R}_n\}). \tag{B2}$$

For given elements i, j , let S_k^{ij} be the subset of the set S_k whose elements P_k satisfy $f_{P_k}(i, j) = 1$. Then the size of the set S_k^{ij} is $n_k := 2^{\binom{M-2}{k-1}}$. Observe that $|S_k^{ij}| = |S_k^{i'j'}|$ holds for any elements $i, j, i',$ and j' . This means that for a given segment entanglement rate $e_{i,j}$ there exist n_k subsets P_k of the set $[M]$ such that $f_{P_k}(i, j) = 1$, i.e.,

$$\sum_{P_k \in S_k} f_{P_k}(i, j) e_{i,j}(\psi, \{\mathcal{R}_n\}) = n_k e_{i,j}(\psi, \{\mathcal{R}_n\}). \tag{B3}$$

From Eqs. (B2) and (B3), it follows that

$$e_{\text{tot}}(\psi, \{\mathcal{R}_n\}) = \sum_{\substack{i, j \in [M] \\ i < j}} e_{i,j}(\psi, \{\mathcal{R}_n\}) = \frac{1}{n_k} \sum_{\substack{i, j \in [M] \\ i < j}} \sum_{P_k \in S_k} f_{P_k}(i, j) e_{i,j}(\psi, \{\mathcal{R}_n\}) \tag{B4}$$

$$= \frac{1}{n_k} \sum_{P_k \in S_k} \sum_{\substack{i, j \in [M] \\ i < j}} f_{P_k}(i, j) e_{i,j}(\psi, \{\mathcal{R}_n\}) = \frac{1}{n_k} \sum_{P_k \in S_k} e_{P_k}(\psi, \{\mathcal{R}_n\}) \geq l_k(\psi). \tag{B5}$$

Here, the last inequality comes from Eq. (A11) and Lemma 2. This shows that $r \geq l_k(\psi)$ holds for any achievable total entanglement rate r and any k .

APPENDIX C: PROOF OF LEMMA 6

Let $\psi_0 = \psi$, and for each $i \in [M - 1]$, we define quantum states ψ_i for the quantum state merging tasks as

$$\psi_i = \left(\bigotimes_{j=1}^i \text{id}_{\mathcal{L}(A_j) \rightarrow \mathcal{L}(A'_j)} \otimes \bigotimes_{j=i+1}^M \text{id}_{\mathcal{L}(A_j)} \otimes \text{id}_{\mathcal{L}(E)} \right) (\psi). \tag{C1}$$

Note that, for each $i \in [M - 1]$, ψ_i is a pure quantum state on the quantum systems

$$\bigotimes_{j=1}^i A'_j \otimes \bigotimes_{j=i+1}^M A_j \otimes E. \tag{C2}$$

For each $i \in [M - 1]$, the i th user and the $(i + 1)$ th user transform the quantum state ψ_{i-1} into the quantum state ψ_i , by means of LOCC and shared entanglement. To be specific, the quantum state on the quantum system A_i of the i th user is asymptotically merged to the $(i + 1)$ th user's quantum system A'_i by using the $(i + 1)$ th user's quantum system A_{i+1} as quantum side information. So, in this case, the remaining quantum systems of the quantum state ψ_{i-1} ,

$$E_i := \bigotimes_{j \in [M] \setminus \{i+1\}} A_j \otimes \bigotimes_{j \in [i-1]} A'_j \otimes E, \tag{C3}$$

are considered as the parts of the environment system. From the definition of the OEC of the quantum state merging [2,3], for each $i \in [M - 1]$, there is a sequence $\{\mathcal{M}_n^{(i)}\}_{n \in \mathbb{N}}$ of LOCC,

$$\mathcal{M}_n^{(i)} : \mathcal{L}(A_i^{\otimes n} \otimes B_{i,i+1}^{(n)} \otimes A_{i+1}^{\otimes n} \otimes B_{i+1,i}^{(n)}) \longrightarrow \mathcal{L}(A_i'^{\otimes n} \otimes C_{i,i+1}^{(n)} \otimes A_{i+1}^{\otimes n} \otimes C_{i+1,i}^{(n)}), \tag{C4}$$

of $\psi_{i-1}^{\otimes n}$ with error $\varepsilon_n^{(i)}$ which merges the part A_i from the i th user to the $(i + 1)$ th user and satisfies $\lim_{n \rightarrow \infty} \varepsilon_n^{(i)} = 0$,

$$\|(\mathcal{M}_n^{(i)} \otimes \text{id}_{\mathcal{L}(E_i^{\otimes n})})(\psi_{i-1}^{\otimes n} \otimes \Psi_n^{(i)}) - \psi_i^{\otimes n} \otimes \Phi_n^{(i)}\|_1 \leq \varepsilon_n^{(i)}, \tag{C5}$$

$$\lim_{n \rightarrow \infty} \frac{1}{n} (\log d_{B_{i,i+1}^{(n)}} - \log d_{C_{i,i+1}^{(n)}}) = H(A_i|A_{i+1}), \tag{C6}$$

where $\Psi_n^{(i)}$ and $\Phi_n^{(i)}$ are pure maximally entangled states on quantum systems $B_{i,i+1}^{(n)}, B_{i+1,i}^{(n)}$ and $C_{i,i+1}^{(n)}, C_{i+1,i}^{(n)}$ shared by the i th user and the $(i + 1)$ th user with Schmidt rank $d_{B_{i,i+1}^{(n)}}$ and $d_{C_{i,i+1}^{(n)}}$, respectively. In addition, from the Schumacher compression [9,16] together with the quantum teleportation [1], there exists a sequence $\{\mathcal{S}_n\}_{n \in \mathbb{N}}$ of LOCC

$$\mathcal{S}_n : \mathcal{L}(A_M^{\otimes n} \otimes B_{M,1}^{(n)} \otimes B_{1,M}^{(n)}) \longrightarrow \mathcal{L}(A_M'^{\otimes n} \otimes C_{M,1}^{(n)} \otimes C_{1,M}^{(n)}) \tag{C7}$$

of $\psi_{M-1}^{\otimes n}$ with error $\varepsilon_n^{(M)}$, which transfers the part A_M from the M th user to the first user and satisfies $\lim_{n \rightarrow \infty} \varepsilon_n^{(M)} = 0$,

$$\|(\mathcal{S}_n \otimes \text{id}_{\mathcal{L}(E_M^{\otimes n})})(\psi_{M-1}^{\otimes n} \otimes \Psi_n^{(M)}) - \psi_f^{\otimes n} \otimes \Phi_n^{(M)}\|_1 \leq \varepsilon_n^{(M)}, \quad (\text{C8})$$

$$\lim_{n \rightarrow \infty} \frac{1}{n} (\log d_{B_{M,1}^{(n)}} - \log d_{C_{M,1}^{(n)}}) = H(A_M), \quad (\text{C9})$$

where $E_M = \bigotimes_{j=1}^{M-1} A_j \otimes E$, and $\Psi_n^{(M)}$ and $\Phi_n^{(M)}$ are pure maximally entangled states on quantum systems $B_{M,1}^{(n)} B_{1,M}^{(n)}$ and $C_{M,1}^{(n)} C_{1,M}^{(n)}$ shared by the first user and the M th user with Schmidt rank $d_{B_{M,1}^{(n)}}$ and $d_{C_{M,1}^{(n)}}$, respectively. For each $n \in \mathbb{N}$, we define LOCC \mathcal{R}_n as

$$\mathcal{R}_n = \mathcal{S}_n \circ \mathcal{M}_n^{(M-1)} \circ \mathcal{M}_n^{(M-2)} \circ \dots \circ \mathcal{M}_n^{(1)}. \quad (\text{C10})$$

We also define quantum states $\tilde{\Psi}_n$, $\tilde{\Phi}_n$, and $\tilde{\Omega}_n^{(i)}$ for each $i \in [M]$ as

$$\tilde{\Psi}_n = \bigotimes_{i \in [M]} \Psi_n^{(i)}, \quad \tilde{\Phi}_n = \bigotimes_{i \in [M]} \Phi_n^{(i)}, \quad \text{and} \quad \tilde{\Omega}_n^{(i)} = \bigotimes_{j=i+1}^M \Psi_n^{(j)} \otimes \bigotimes_{j=1}^{i-1} \Phi_n^{(j)}. \quad (\text{C11})$$

Observe that, for $i = 2, \dots, M-1$, the inequalities

$$\begin{aligned} & \|(\mathcal{M}_n^{(i)} \circ \dots \circ \mathcal{M}_n^{(1)})(\psi^{\otimes n} \otimes \tilde{\Psi}_n) - \psi_i^{\otimes n} \otimes \Psi_n^{(i+1)} \otimes \tilde{\Omega}_n^{(i+1)}\|_1 \\ & \leq \|(\mathcal{M}_n^{(i)} \circ \dots \circ \mathcal{M}_n^{(1)})(\psi^{\otimes n} \otimes \tilde{\Psi}_n) - (\mathcal{M}_n^{(i)} \otimes \text{id}_{\mathcal{L}(E_i^{\otimes n})})(\psi_{i-1}^{\otimes n} \otimes \Psi_n^{(i)}) \otimes \tilde{\Omega}_n^{(i)}\|_1 \\ & \quad + \|(\mathcal{M}_n^{(i)} \otimes \text{id}_{\mathcal{L}(E_i^{\otimes n})})(\psi_{i-1}^{\otimes n} \otimes \Psi_n^{(i)}) \otimes \tilde{\Omega}_n^{(i)} - \psi_i^{\otimes n} \otimes \Psi_n^{(i+1)} \otimes \tilde{\Omega}_n^{(i+1)}\|_1 \\ & \leq \|(\mathcal{M}_n^{(i-1)} \circ \dots \circ \mathcal{M}_n^{(1)})(\psi^{\otimes n} \otimes \tilde{\Psi}_n) - \psi_{i-1}^{\otimes n} \otimes \Psi_n^{(i)} \otimes \tilde{\Omega}_n^{(i)}\|_1 + \|(\mathcal{M}_n^{(i)} \otimes \text{id}_{\mathcal{L}(E_i^{\otimes n})})(\psi_{i-1}^{\otimes n} \otimes \Psi_n^{(i)}) - \psi_i^{\otimes n} \otimes \Phi_n^{(i)}\|_1 \end{aligned} \quad (\text{C12})$$

$$\leq \|(\mathcal{M}_n^{(i-1)} \circ \dots \circ \mathcal{M}_n^{(1)})(\psi^{\otimes n} \otimes \tilde{\Psi}_n) - \psi_{i-1}^{\otimes n} \otimes \Psi_n^{(i)} \otimes \tilde{\Omega}_n^{(i)}\|_1 + \|(\mathcal{M}_n^{(i)} \otimes \text{id}_{\mathcal{L}(E_i^{\otimes n})})(\psi_{i-1}^{\otimes n} \otimes \Psi_n^{(i)}) - \psi_i^{\otimes n} \otimes \Phi_n^{(i)}\|_1 \quad (\text{C13})$$

hold, where the first inequality and the second inequality come from the triangle property and the monotonicity of the trace distance [9], and other identity maps $\text{id}_{E^{\otimes n}}$, and $\text{id}_{E_i^{\otimes n}}$ are omitted for convenience. Then we have

$$\begin{aligned} & \|(\mathcal{R}_n \otimes \text{id}_{E^{\otimes n}})(\psi^{\otimes n} \otimes \tilde{\Psi}_n) - \psi_f^{\otimes n} \otimes \tilde{\Phi}_n\|_1 \\ & \leq \|(\mathcal{R}_n \otimes \text{id}_{E^{\otimes n}})(\psi^{\otimes n} \otimes \tilde{\Psi}_n) - (\mathcal{S}_n \otimes \text{id}_{\mathcal{L}(E_M^{\otimes n})})(\psi_{M-1}^{\otimes n} \otimes \Psi_n^{(M)}) \otimes \tilde{\Omega}_n^{(M)}\|_1 \\ & \quad + \|(\mathcal{S}_n \otimes \text{id}_{\mathcal{L}(E_M^{\otimes n})})(\psi_{M-1}^{\otimes n} \otimes \Psi_n^{(M)}) \otimes \tilde{\Omega}_n^{(M)} - \psi_f^{\otimes n} \otimes \tilde{\Phi}_n\|_1 \end{aligned} \quad (\text{C14})$$

$$\leq \|(\mathcal{M}_n^{(M-1)} \circ \dots \circ \mathcal{M}_n^{(1)})(\psi^{\otimes n} \otimes \tilde{\Psi}_n) - \psi_{M-1}^{\otimes n} \otimes \Psi_n^{(M)} \otimes \tilde{\Omega}_n^{(M)}\|_1 + \|(\mathcal{S}_n \otimes \text{id}_{\mathcal{L}(E_M^{\otimes n})})(\psi_{M-1}^{\otimes n} \otimes \Psi_n^{(M)}) - \psi_f^{\otimes n} \otimes \Phi_n^{(M)}\|_1 \quad (\text{C15})$$

$$\leq \|(\mathcal{M}_n^{(1)})(\psi^{\otimes n} \otimes \tilde{\Psi}_n) - \psi_1^{\otimes n} \otimes \Psi_n^{(2)} \otimes \tilde{\Omega}_n^{(2)}\|_1 + \sum_{i=2}^{M-1} \|(\mathcal{M}_n^{(i)} \otimes \text{id}_{\mathcal{L}(E_i^{\otimes n})})(\psi_{i-1}^{\otimes n} \otimes \Psi_n^{(i)}) - \psi_i^{\otimes n} \otimes \Phi_n^{(i)}\|_1 \quad (\text{C16})$$

$$\begin{aligned} & + \|(\mathcal{S}_n \otimes \text{id}_{\mathcal{L}(E_M^{\otimes n})})(\psi_{M-1}^{\otimes n} \otimes \Psi_n^{(M)}) - \psi_f^{\otimes n} \otimes \Phi_n^{(M)}\|_1 \\ & = \sum_{i=1}^{M-1} \|(\mathcal{M}_n^{(i)} \otimes \text{id}_{\mathcal{L}(E_i^{\otimes n})})(\psi_{i-1}^{\otimes n} \otimes \Psi_n^{(i)}) - \psi_i^{\otimes n} \otimes \Phi_n^{(i)}\|_1 + \|(\mathcal{S}_n \otimes \text{id}_{\mathcal{L}(E_M^{\otimes n})})(\psi_{M-1}^{\otimes n} \otimes \Psi_n^{(M)}) - \psi_f^{\otimes n} \otimes \Phi_n^{(M)}\|_1 \leq \sum_{i=1}^M \varepsilon_n^{(i)}. \end{aligned} \quad (\text{C17})$$

Here, the first inequality and the second inequality hold from the triangle property and the monotonicity of the trace distance again. The third inequality is obtained by repeatedly applying the inequality in Eq. (C12). Since $\psi = \psi_0$, the last equality holds. The last inequality comes from Eqs. (C5) and (C8). Set $\varepsilon_n = \sum_{i=1}^M \varepsilon_n^{(i)}$. Then $\lim_{n \rightarrow \infty} \varepsilon_n = 0$, since $\lim_{n \rightarrow \infty} \varepsilon_n^{(i)} = 0$ holds for each $i \in [M]$. It follows that there is a sequence $\{\mathcal{R}_n\}_{n \in \mathbb{N}}$ of QSR protocols \mathcal{R}_n of $|\psi\rangle^{\otimes n}$ with error ε_n such that $\lim_{n \rightarrow \infty} \varepsilon_n = 0$,

$$e_{i,j}(\psi, \{\mathcal{R}_n\}) = \begin{cases} H(A_i|A_{i+1}) & \text{if } i \in [M-1] \text{ and } j = i+1 \\ H(A_M) & \text{if } i = M \text{ and } j = 1 \\ 0 & \text{otherwise,} \end{cases} \quad (\text{C18})$$

$$e_{\text{tot}}(\psi, \{\mathcal{R}_n\}) = H(A_M) + \sum_{i=1}^{M-1} H(A_i|A_{i+1}). \quad (\text{C19})$$

APPENDIX D: PROOF OF THEOREM 11

To prove Theorem 11, we use the following lemma.

Lemma 20. The lower bound $l_1(\psi)$ shown in Theorem 3 is lower bounded by

$$l_1(\psi) \geq \frac{1}{2} \max_{D \subseteq [M]} \left| \sum_{i_j \in D} (-1)^j H(E|A_{i_j})_\psi \right|, \tag{D1}$$

where D denotes a subset $\{i_1, i_2, \dots, i_{2k}\}$ of the set $[M]$ with $k = 1, \dots, \lfloor M/2 \rfloor$ and $i_1 < i_2 < \dots < i_{2k}$, and the maximum is taken over all possible subsets D whose sizes are even.

Proof. It is easy to check that $l_1(\psi)$ is lower bounded by

$$\frac{1}{2} \sum_{i=1}^M \max \{H(A_{i-1})_\psi - H(A_i)_\psi, H(A_{i-1}E)_\psi - H(A_iE)_\psi\}, \tag{D2}$$

by using the definition of the lower bound $l_i(\psi)$ in Eq. (19). So it suffices to show the equality LHS = RHS, where LHS and RHS are defined as

$$\text{LHS} = \sum_{i=1}^M \max \{\alpha_i, \beta_i\} \quad \text{and} \quad \text{RHS} = \max_{D \subseteq [M]} \left| \sum_{i_j \in D} (-1)^j H(E|A_{i_j})_\psi \right|, \tag{D3}$$

with $\alpha_i = H(A_{i-1})_\psi - H(A_i)_\psi$ and $\beta_i = H(A_{i-1}E)_\psi - H(A_iE)_\psi$.

(i) To show LHS \leq RHS, we use functions $f_i : \{0, 1\} \rightarrow \mathbb{R}$ defined as $f_i(x) = (1-x)\alpha_i + x\beta_i$. Let b be an M -bit string $b = b_1b_2 \dots b_M$ such that $b_i \in \{0, 1\}$ for each i . Then LHS is represented as

$$\text{LHS} = \max_b \sum_{i=1}^M f_i(b_i), \tag{D4}$$

where the maximum is taken over all M -bit strings. In addition, we observe that the equalities

$$\sum_{i=1}^M f_i(b_i) = \sum_{i=1}^M [(1-b_i)\alpha_i + b_i\beta_i] = \sum_{i=1}^M b_i(\beta_i - \alpha_i) = \sum_{i=1}^M (b_i - 1)\beta_i - \sum_{i=1}^M b_i\alpha_i = - \sum_{i=1}^M [(1 - (1 - b_i))\alpha_i + (1 - b_i)\beta_i] \tag{D5}$$

$$= - \sum_{i=1}^M f_i(1 - b_i) \tag{D6}$$

hold for any M -bit string b , where the second equality and the third equality come from equalities $\sum_{i=1}^M \alpha_i = \sum_{i=1}^M \beta_i = 0$. This implies

$$\text{LHS} = \max_b \left| \sum_{i=1}^M f_i(b_i) \right|, \tag{D7}$$

where the maximum is taken over all M -bit strings having k zero bits with $1 \leq k \leq \lfloor M/2 \rfloor$. For any M -bit string $b = b_1b_2 \dots b_M$ with k bits in state zero, we can express k zero bits and the other bits in state one using two functions $g_b : [k] \rightarrow [M]$ and $h_b : [M - k] \rightarrow [M]$ satisfying $b_{g_b(i)} = 0$ and $b_{h_b(i)} = 1$, respectively. Observe that

$$\sum_{i=1}^M f_i(b_i) = \sum_{i=1}^k f_{g_b(i)}(0) + \sum_{i=1}^{M-k} f_{h_b(i)}(1) = \sum_{i=1}^k f_{g_b(i)}(0) - \sum_{i=1}^k f_{g_b(i)}(1) = \sum_{i=1}^k [H(E|A_{g_b(i)})_\psi - H(E|A_{g_b(i)-1})_\psi] \tag{D8}$$

$$= \sum_{i \in X} H(E|A_i)_\psi - \sum_{i \in Y} H(E|A_i)_\psi, \tag{D9}$$

where $X = \{g_b(i) : i \in [k]\}$ and $Y = \{g_b(i) - 1 : i \in [k]\}$. The second equality comes from the simple fact

$$\sum_{i=1}^k f_{g_b(i)}(1) + \sum_{i=1}^{M-k} f_{h_b(i)}(1) = \sum_{i=1}^M f_i(1) = 0. \tag{D10}$$

Since $1 \leq k \leq \lfloor M/2 \rfloor$, the set X is nonempty. Let l_X be the largest element of the set X . Then $l_X \notin Y$, by the definition of the set Y , and so $X \setminus Y$ is nonempty. Assume that $|X| = |Y| = s > 0$ and $|X \setminus Y| = |X \setminus Y| = t > 0$ for some natural numbers s and t with $t \leq s$. Then we can represent the sets $X, Y, X \setminus Y$, and $X \setminus Y$ as

$$X = \{x_1, x_2, \dots, x_s\}, \quad Y = \{y_1, y_2, \dots, y_s\}, \quad X \setminus Y = \{a_1, a_2, \dots, a_t\}, \quad Y \setminus X = \{b_1, b_2, \dots, b_t\}, \tag{D11}$$

where $x_i < x_j$ and $y_i < y_j$ for each $i, j \in [s]$ with $i < j$, and $a_k < a_l$ and $b_k < b_l$ for each $k, l \in [t]$ with $k < l$.

For each $i \in [s - 1]$, we consider two consecutive elements x_i and x_{i+1} of the set X . By the definition of the set Y , $x_i - 1 \in Y$ and $x_{i+1} - 1 \in Y$. If $x_i + 1 = x_{i+1}$, then $x_i = x_{i+1} - 1 \in Y$, and so $x_i \notin X \setminus Y$. Conversely, if $x_i \notin X \setminus Y$, then $x_i \in Y$. By the definition of the set Y , $x_i + 1 \in X$. Since $x_i < x_{i+1}$, we have $x_{i+1} = x_i + 1$. Thus, we obtain that, for each $i \in [s - 1]$,

$$x_i + 1 = x_{i+1} \quad \text{if and only if} \quad x_i \notin X \setminus Y. \tag{D12}$$

Similarly to the above equivalence, we also obtain that, for each $i \in [s - 1]$,

$$y_i + 1 = y_{i+1} \quad \text{if and only if} \quad y_{i+1} \notin Y \setminus X. \tag{D13}$$

Note that $x_1 \leq a_1$ holds in general, and equalities $x_1 - 1 = y_1 = b_1$ also hold, by the definition of the set Y . Thus, $b_1 < a_1$.

For the case that $x_1 = a_1$, we have $a_1 = b_1 + 1$. If $b_2 = b_1 + 1$, then $a_1 + 1 = b_2 + 1 \in X$, by the definition of the set Y . From Eq. (D12), $a_1 \in X$ and $a_1 + 1 \in X$ means $a_1 \notin X \setminus Y$, which contradicts $a_1 \in X \setminus Y$. Thus, $a_1 = b_1 + 1 < b_2$. For the case that $x_1 < a_1$, we have $x_1 \notin X \setminus Y$, since a_1 is the smallest element of $X \setminus Y$. From Eq. (D12), this means that $x_1 + 1$ is an element of the set X . If $x_1 + 1 < a_1$, then $x_1 \notin X \setminus Y$, since a_1 is the smallest element of $X \setminus Y$, and Eq. (D12) implies that $x_1 + 2$ is an element of the set X . In this way, we find a subset $\{x_1, x_1 + 1, \dots, a_1\}$ of the set X , and so a set $\{x_1 - 1, x_1, \dots, a_1 - 1\}$ is a subset of the set Y , by the definition of the set Y . From Eq. (D13), we obtain $a_1 \leq b_2$. In addition, since a_1 is the element of the set $X \setminus Y$, b_2 cannot be equal to a_1 . Thus, $a_1 < b_2$.

If $a_2 \leq b_2$, then $a_2 - 1 \in Y$, by the definition of the set Y . Since b_2 is the second smallest element of the set $Y \setminus X$, $a_2 - 1 \notin Y \setminus X$. From Eq. (D13), $a_2 - 1 \notin Y \setminus X$ implies $a_2 - 2 \in Y$. If $b_1 < a_2 - 2$, then $a_2 - 2 \notin Y \setminus X$, since b_2 is the second smallest element of the set $Y \setminus X$, and so $a_2 - 3 \in Y$ from Eq. (D13). In this way, we find a subset $\{b_1, b_1 + 1, \dots, a_2 - 1\}$ of the set Y , and so we obtain that $a_1 \in \{b_1 + 1, b_1 + 2, \dots, a_2\} \subset X$, by the definition of the set Y . From Eq. (D12), $a_1 \notin X \setminus Y$. In addition, since a_1 is the element of the set $X \setminus Y$, b_2 cannot be equal to a_1 . Thus, $a_1 < b_2$, which is a contradiction. Thus, $b_2 < a_2$.

Consequently, we have shown that $b_1 < a_1 < b_2 < a_2$. By repeatedly applying the above process, we obtain that $b_i < a_i < b_{i+1} < a_{i+1}$ for each $i \in [t - 1]$. This shows that there is a subset $D = \{i_1, i_2, \dots, i_{2k}\}$ of $[M]$ with $k \in \{1, \dots, \lfloor M/2 \rfloor\}$ such that $i_1 < i_2 < \dots < i_{2k}$, for each $j \in [k]$, $i_{2j-1} \in Y \setminus X$ and $i_{2j} \in X \setminus Y$,

$$\sum_{i=1}^M f_i(b_i) = \sum_{i_j \in D} (-1)^j H(E|A_{i_j})_\psi. \tag{D14}$$

Thus, LHS \leq RHS holds, since the M -bit string b with k zero bits is arbitrary.

(ii) We show LHS \geq RHS. Let $D = \{i_1, i_2, \dots, i_{2k}\}$ be a subset of $[M]$ with $k \in \{1, \dots, \lfloor M/2 \rfloor\}$ and $i_1 < i_2 < \dots < i_{2k}$ satisfying RHS = $|\sum_{i_j \in D} (-1)^j H(E|A_{i_j})_\psi|$. Set an M -bit string b as follows:

$$b_j = \begin{cases} 1 & \text{if } j \in \{i_1, i_3, \dots, i_{2k-1}\} \\ 0 & \text{if } j \in \{i_2, i_4, \dots, i_{2k}\} \\ b_{j+1} & \text{otherwise,} \end{cases} \tag{D15}$$

where b_M is defined as b_1 when $M \notin D$. We obtain the following equalities:

$$\sum_{j=1}^M f_j(b_j) = \sum_{j=1}^{i_1} f_j(1) + \sum_{j=1}^k \sum_{l=i_{2j-1}+1}^{i_{2j}} f_l(0) + \sum_{j=1}^{k-1} \sum_{l=i_{2j}+1}^{i_{2j+1}} f_l(1) + \sum_{j=i_{2k}+1}^M f_j(1) \tag{D16}$$

$$= \sum_{j=1}^{i_1} \beta_j + \sum_{j=1}^k \sum_{l=i_{2j-1}+1}^{i_{2j}} \alpha_l + \sum_{j=1}^{k-1} \sum_{l=i_{2j}+1}^{i_{2j+1}} \beta_l + \sum_{j=i_{2k}+1}^M \beta_j \tag{D17}$$

$$= \left(\sum_{j=i_{2k}+1}^M \beta_j + \sum_{j=1}^{i_1} \beta_j \right) + \sum_{j=1}^k \sum_{l=i_{2j-1}+1}^{i_{2j}} \alpha_l + \sum_{j=1}^{k-1} \sum_{l=i_{2j}+1}^{i_{2j+1}} \beta_l \tag{D18}$$

$$= (H(A_{i_{2k}}E)_\psi - H(A_{i_1}E)_\psi) + \sum_{j=1}^k [H(A_{i_{2j-1}})_\psi - H(A_{i_{2j}})_\psi] + \sum_{j=1}^{k-1} [H(A_{i_{2j}}E)_\psi - H(A_{i_{2j+1}}E)_\psi] \tag{D19}$$

$$= H(A_{i_{2k}}E)_\psi - H(A_{i_1}E)_\psi + H(A_{i_{2k-1}})_\psi - H(A_{i_{2k}})_\psi + \sum_{j=1}^{k-1} [H(A_{i_{2j-1}})_\psi - H(A_{i_{2j}})_\psi] + \sum_{j=1}^{k-1} [H(A_{i_{2j}}E)_\psi - H(A_{i_{2j+1}}E)_\psi] \tag{D20}$$

$$= H(E|A_{i_{2k}})_\psi - H(A_{i_1}E)_\psi + H(A_{i_{2k-1}})_\psi + \sum_{j=1}^{k-1} H(A_{i_{2j-1}})_\psi + \sum_{j=1}^{k-1} H(E|A_{i_{2j}})_\psi - \sum_{j=1}^{k-1} H(A_{i_{2j+1}}E)_\psi \tag{D21}$$

$$= \left(H(E|A_{i_{2k}})_\psi + \sum_{j=1}^{k-1} H(E|A_{i_{2j}})_\psi \right) + \left(H(A_{i_{(2k-1)}})_\psi + \sum_{j=1}^{k-1} H(A_{i_{(2j-1)}})_\psi - H(A_{i_1}E)_\psi - \sum_{j=2}^k H(A_{i_{(2j-1)}}E)_\psi \right) \tag{D22}$$

$$= \sum_{j=1}^k H(E|A_{i_{2j}})_\psi - \sum_{j=1}^k H(E|A_{i_{(2j-1)}})_\psi \tag{D23}$$

$$= \sum_{j=1}^{2k} (-1)^j H(E|A_{i_j})_\psi, \tag{D24}$$

where the fourth equality comes from the fact that

$$\sum_{i=n}^m \beta_i = H(A_{n-1}E)_\psi - H(A_mE)_\psi, \quad \sum_{i=n}^m \alpha_i = H(A_{n-1})_\psi - H(A_m)_\psi. \tag{D25}$$

In the case that the sum $\sum_{i_j \in D} (-1)^j H(E|A_{i_j})_\psi$ is negative, we can find another M -bit string b' satisfying $b'_i = 1 - b_i$, where b_i is the i th bit of the M -bit string b defined in Eq. (D15). By using the relation in Eq. (D5), we obtain

$$\sum_{j=1}^M f_j(b'_j) = - \sum_{i_j \in D} (-1)^j H(E|A_{i_j})_\psi. \tag{D26}$$

It follows that LHS \geq RHS. ■

Proof of Theorem 11. We prove the contrapositive of Theorem 11. Suppose that $e_{\text{opt}}(\psi) = 0$. Then $l_1(\psi) = 0$, since the lower bound l_i on the OEC is non-negative. So Lemma 20 implies

$$\max_{D \subseteq [M]} \left| \sum_{i_j \in D} (-1)^j H(E|A_{i_j})_\psi \right| = 0, \tag{D27}$$

where D is a subset $\{i_1, i_2, \dots, i_{2k}\}$ of the set $[M]$ with $k = 1, \dots, \lfloor M/2 \rfloor$ and $i_1 < i_2 < \dots < i_{2k}$. By choosing D as a set $\{i, j\}$ with $i \neq j$, we obtain $H(E|A_i)_\psi = H(E|A_j)_\psi$ for any i, j . ■

APPENDIX E: PROOF OF THEOREM 13

To prove Theorem 13, we use the following lemma.

Lemma 21. Let $|\psi\rangle_{AE}$ be the initial state of the QSR task, and let $\{\mathcal{R}_n\}_{n \in \mathbb{N}}$ be a sequence of QSR protocols \mathcal{R}_n of $|\psi\rangle^{\otimes n}$ with error ε_n whose total entanglement rate r is achievable. If $r = 0$, then

$$e_P(\psi, \{\mathcal{R}_n\}) = l_P(\psi) \tag{E1}$$

holds for any nonempty proper subset P of $[M]$, where e_P and l_P are defined in Eq. (A11) and Eq. (17), respectively.

Proof. Since $r = 0$, Theorem 3 and Remark 4 imply that the lower bound $l_i(\psi)$ in Eq. (19) is zero for each $i \in [M]$.

Suppose that there exists a nonempty proper subset Q of $[M]$ such that $e_Q(\psi, \{\mathcal{R}_n\}) \neq l_Q(\psi)$. Then Lemma 2 implies

$$e_Q(\psi, \{\mathcal{R}_n\}) > l_Q(\psi). \tag{E2}$$

If the size of the set Q is k , then we consider the set S_k of subsets P_k of $[M]$ whose size is k , so that $Q \in S_k$. Then we can obtain

$$0 = e_{\text{tot}}(\psi, \{\mathcal{R}_n\}) = \frac{1}{n_k} \sum_{P_k \in S_k} e_{P_k}(\psi, \{\mathcal{R}_n\}) > \frac{1}{n_k} \sum_{P_k \in S_k} l_{P_k}(\psi) = l_k(\psi) = 0, \tag{E3}$$

where $n_k = 2^{\binom{M-2}{k-1}}$, which is a contradiction. Here, the second equality and the inequality come from Eqs. (B5) and (E2), respectively. Consequently, $e_P(\psi, \{\mathcal{R}_n\}) = l_P(\psi)$ holds for any nonempty proper subset P of $[M]$. ■

Proof of Theorem 13. Since $r = 0$, Lemma 21 implies that

$$\sum_{i \in P} \sum_{j \in P^c} e_{i,j}(\psi, \{\mathcal{R}_n\}) = l_P(\psi) \tag{E4}$$

holds for any nonempty proper subset P of $[M]$. This can be interpreted as the following linear equation, if we consider the segment entanglement rates $e_{i,j}(\psi, \{\mathcal{R}_n\})$ and the lower bounds $l_P(\psi)$ as unknowns and coefficients:

$$\sum_{i=1}^M \sum_{j=1}^M c_{i,j}(P) e_{i,j}(\psi, \{\mathcal{R}_n\}) = l_P(\psi), \tag{E5}$$

where the coefficient $c_{i,j}(P)$ is defined as

$$c_{i,j}(P) = \begin{cases} \frac{1}{2} & \text{if } (i \in P, j \in P^c) \text{ or } (j \in P, i \in P^c) \\ 0 & \text{otherwise.} \end{cases} \tag{E6}$$

Note that $e_{i,i}(\psi, \{\mathcal{R}_n\}) = 0$ and $e_{j,i}(\psi, \{\mathcal{R}_n\}) = e_{i,j}(\psi, \{\mathcal{R}_n\})$ for each $i, j \in [M]$. In this way, we construct a system of linear equations for each case as follows.

(i) For $M = 3$, there exist three unknowns of $e_{i,j}(\psi, \{\mathcal{R}_n\})$. Consider the sets $P \subseteq [3]$ whose sizes are one. Then, from Eq. (E4), we obtain that

$$e_{i,i+1}(\psi, \{\mathcal{R}_n\}) + e_{i,i+2}(\psi, \{\mathcal{R}_n\}) = l_{\{i\}}(\psi) \tag{E7}$$

for each i . This can be expressed as a system of linear equations as follows:

$$\begin{pmatrix} 1 & 0 & 1 \\ 1 & 1 & 0 \\ 0 & 1 & 1 \end{pmatrix} \begin{pmatrix} e_{1,2}(\psi, \{\mathcal{R}_n\}) \\ e_{2,3}(\psi, \{\mathcal{R}_n\}) \\ e_{1,3}(\psi, \{\mathcal{R}_n\}) \end{pmatrix} = \begin{pmatrix} l_{\{1\}}(\psi) \\ l_{\{2\}}(\psi) \\ l_{\{3\}}(\psi) \end{pmatrix}. \tag{E8}$$

Note that if we consider other sets P whose sizes are $k > 1$, then we can have a different representation of the linear equations in Eq. (E8). By simply solving this system, we obtain

$$e_{i,j}(\psi, \{\mathcal{R}_n\}) = \frac{1}{2}(l_{\{i\}}(\psi) + l_{\{j\}}(\psi) - l_{\{k\}}(\psi)), \tag{E9}$$

where $\{i, j, k\} = [3]$, which becomes $e_{i,j}(\psi, \{\mathcal{R}_n\}) = -l_{\{k\}}(\psi) = -l_{\{i,j\}}(\psi)$, since $l_1(\psi) = 0$.

(ii) Similarly, the system of linear equations corresponding to the case of $M = 4$ can be represented as

$$\begin{pmatrix} 1 & 0 & 0 & 1 & 1 & 0 \\ 1 & 1 & 0 & 0 & 0 & 1 \\ 0 & 1 & 1 & 0 & 1 & 0 \\ 0 & 0 & 1 & 1 & 0 & 1 \\ 0 & 1 & 0 & 1 & 1 & 1 \\ 1 & 0 & 1 & 0 & 1 & 1 \end{pmatrix} \begin{pmatrix} e_{1,2}(\psi, \{\mathcal{R}_n\}) \\ e_{2,3}(\psi, \{\mathcal{R}_n\}) \\ e_{3,4}(\psi, \{\mathcal{R}_n\}) \\ e_{1,4}(\psi, \{\mathcal{R}_n\}) \\ e_{1,3}(\psi, \{\mathcal{R}_n\}) \\ e_{2,4}(\psi, \{\mathcal{R}_n\}) \end{pmatrix} = \begin{pmatrix} l_{\{1\}}(\psi) \\ l_{\{2\}}(\psi) \\ l_{\{3\}}(\psi) \\ l_{\{4\}}(\psi) \\ l_{\{1,2\}}(\psi) \\ l_{\{2,3\}}(\psi) \end{pmatrix}, \tag{E10}$$

and its solution is given by

$$e_{i,j}(\psi, \{\mathcal{R}_n\}) = \frac{1}{2}(l_{\{i\}}(\psi) + l_{\{j\}}(\psi) - l_{\{i,j\}}(\psi)). \tag{E11}$$

Recall that, for any partition $\{P, P^c\}$ of the set $[M]$, $l_P(\psi) = l_{P^c}(\psi)$ holds. For example, $l_{\{1,2\}}(\psi) = l_{\{3,4\}}(\psi)$ when $M = 4$.

(iii) Set $N = M(M - 1)/2$. If $M > 4$, the number of unknowns of $e_{i,j}(\psi, \{\mathcal{R}_n\})$ is N . In this case, it suffices to consider subsets P_2 of $[M]$ whose size is two in order to construct a system of linear equations. To be specific, there exist N different linear equations

$$\sum_{i=1}^M \sum_{j=1}^M c_{i,j}(P_2) e_{i,j}(\psi, \{\mathcal{R}_n\}) = l_{P_2}(\psi), \tag{E12}$$

so we have a system of N linear equations with N unknowns. This system of linear equations can be represented as a matrix equation of the form

$$D_M x_M = b_M, \tag{E13}$$

where the matrix D_M is $N \times N$, and the matrices x_M and b_M are $N \times 1$. To describe entries of these matrices, we use a bijective function $f_M : [N] \rightarrow T_M$, where T_M is the set of all two-element subsets P_2 of $[M]$. Then the entries of the matrices D_M , x_M , and b_M are given by

$$[D_M]_{s,t} = \begin{cases} 0 & \text{if } s = t \\ 1 & \text{if } s \neq t \text{ and } f_M(s) \cap f_M(t) \neq \emptyset \\ 0 & \text{if } s \neq t \text{ and } f_M(s) \cap f_M(t) = \emptyset, \end{cases} \tag{E14}$$

$$[x_M]_{s,1} = e_{f_M(s)}(\psi, \{\mathcal{R}_n\}), \tag{E15}$$

$$[b_M]_{s,1} = l_{f_M(s)}(\psi), \tag{E16}$$

where $[D_M]_{s,t}$ is derived from the coefficients $c_{i,j}(P_2)$ in Eq. (E12), and $e_{f_M(s)}(\psi, \{\mathcal{R}_n\})$ indicates the segment entanglement rate $e_{i_s j_s}(\psi, \{\mathcal{R}_n\})$ if $f_M(s) = \{i_s, j_s\} \subset [M]$.

Now, we show that the matrix D_M is invertible. Consider an $N \times N$ matrix D_M^{-1} defined as

$$[D_M^{-1}]_{s,t} = \begin{cases} \beta_M/\alpha_M & \text{if } s = t \\ \gamma_M/\alpha_M & \text{if } s \neq t \text{ and } f_M(s) \cap f_M(t) \neq \emptyset \\ -2/\alpha_M & \text{if } s \neq t \text{ and } f_M(s) \cap f_M(t) = \emptyset, \end{cases} \quad (\text{E17})$$

where $\alpha_M = 2(M - 2)(M - 4)$, $\beta_M = 2 - (M - 4)^2$, and $\gamma_M = M - 4$. For each $s \neq t$, define subsets $T_{s,s}^{(1)}$ and $T_{s,t}^{(i)}$ of $[N]$ as follows:

$$T_{s,s}^{(1)} = \{k \in [N] : k \neq s, |f_M(k) \cap f_M(s)| = 1\}, \quad (\text{E18})$$

$$T_{s,t}^{(2)} = \{k \in [N] : s = k, t \neq k, f_M(t) \cap f_M(k) \neq \emptyset\}, \quad (\text{E19})$$

$$T_{s,t}^{(3)} = \{k \in [N] : s \neq k, f_M(s) \cap f_M(k) \neq \emptyset, t \neq k, f_M(t) \cap f_M(k) \neq \emptyset\}, \quad (\text{E20})$$

$$T_{s,t}^{(4)} = \{k \in [N] : s \neq k, f_M(s) \cap f_M(k) = \emptyset, t \neq k, f_M(t) \cap f_M(k) \neq \emptyset\}. \quad (\text{E21})$$

The sizes of these sets are given by

$$|T_{s,s}^{(1)}| = 2(M - 2), \quad (\text{E22})$$

$$|T_{s,t}^{(2)}| = \begin{cases} 1 & \text{if } f_M(s) \cap f_M(t) \neq \emptyset \\ 0 & \text{otherwise,} \end{cases} \quad (\text{E23})$$

$$|T_{s,t}^{(3)}| = \begin{cases} M - 2 & \text{if } f_M(s) \cap f_M(t) \neq \emptyset \\ 4 & \text{otherwise,} \end{cases} \quad (\text{E24})$$

$$|T_{s,t}^{(4)}| = \begin{cases} M - 3 & \text{if } f_M(s) \cap f_M(t) \neq \emptyset \\ 2(M - 4) & \text{otherwise.} \end{cases} \quad (\text{E25})$$

We obtain that the diagonal entries of the matrix $D_M^{-1}D_M$ are

$$[D_M^{-1}D_M]_{s,s} = \sum_{k=1}^N [D_M^{-1}]_{s,k} [D_M]_{s,k} = \frac{\gamma_M}{\alpha_M} |T_{s,s}^{(1)}| = \frac{\gamma_M}{\alpha_M} 2(M - 2) = 1. \quad (\text{E26})$$

Since the matrix D_M is symmetric, the first equality holds, and by directly comparing Eqs. (E14) and (E17) we obtain the second equality. On the other hand, observe that the equality

$$[D_M^{-1}]_{s,k} [D_M]_{k,t} = \begin{cases} \beta_M/\alpha_M & \text{if } k \in T_{s,t}^{(2)} \\ \gamma_M/\alpha_M & \text{if } k \in T_{s,t}^{(3)} \\ -2/\alpha_M & \text{if } k \in T_{s,t}^{(4)} \\ 0 & \text{otherwise} \end{cases} \quad (\text{E27})$$

holds for any $s, t, k \in [N]$ with $s \neq t$. From the above equation, the off-diagonal entries of the matrix $D_M^{-1}D_M$ are calculated as

$$[D_M^{-1}D_M]_{s,t} = \sum_{k=1}^N [D_M^{-1}]_{s,k} [D_M]_{k,t} = \frac{1}{\alpha_M} (\beta_M |T_{s,t}^{(2)}| + \gamma_M |T_{s,t}^{(3)}| - 2|T_{s,t}^{(4)}|) = 0. \quad (\text{E28})$$

This shows that the matrix D_M^{-1} is the inverse of the matrix D_M , and so $x_M = D_M^{-1}b_M$. ■

APPENDIX F: PROOF OF LEMMA 17

To prove Lemma 17, we use the relative entropy of entanglement [29] between the second user and the third user instead of the entanglement entropy between each user and the other two users, since the entanglement entropies for the initial and final states are the same.

Suppose that there exists a sequence $\{\mathcal{T}_n\}_{n \in \mathbb{N}}$ of LOCC \mathcal{T}_n of $\phi^{\otimes n}$ with error ε_n such that $e_{i,j}(\phi, \{\mathcal{T}_n\}) = 0$ for each i, j and $\lim_{n \rightarrow \infty} \varepsilon_n = 0$, where the segment entanglement rate $e_{i,j}$ is defined in Eq. (11). From the monotonicity of the trace distance [9], we obtain that

$$\delta_n = \left\| \text{Tr}_{A_1^{\otimes n} A_2^{\otimes n} F_{1,2}^{(n)} F_{1,3}^{(n)}} [\phi_i^{\otimes n} \otimes \tilde{\Phi}_n] - \text{Tr}_{A_1^{\otimes n} A_2^{\otimes n} F_{1,2}^{(n)} F_{1,3}^{(n)}} [\mathcal{T}_n(\phi^{\otimes n} \otimes \tilde{\Psi}_n)] \right\|_1 \leq \varepsilon_n. \quad (\text{F1})$$

Let $D(\varrho \parallel \tau)$ be the quantum relative entropy between two mixed states ϱ and τ , i.e., $D(\varrho \parallel \tau) = \text{Tr}[\varrho(\log \varrho - \log \tau)]$. Then the relative entropy of entanglement of ϱ_{XY} is defined by

$$E_R(X; Y)_\varrho = \min_{\tau_{XY} \in \text{SEP}(X; Y)} D(\varrho_{XY} \parallel \tau_{XY}), \quad (\text{F2})$$

where $\text{SEP}(X; Y)$ is the set of all separable states on the system XY . From the continuity of the relative entropy of entanglement [29], if $\delta_n \leq 1/3$, then we have

$$2(\delta_n(n \log d_{B'_1 B'_2 C'_1 C'_2} + \log d_{F_{2,1}^{(n)} F_{2,3}^{(n)} F_{3,1}^{(n)} F_{3,2}^{(n)}}) - \delta_n \log \delta_n) + 4\delta_n \quad (\text{F3})$$

$$\geq |E_R(B'_1{}^{\otimes n} B'_2{}^{\otimes n} F_{2,1}^{(n)} F_{2,3}^{(n)}; C'_1{}^{\otimes n} C'_2{}^{\otimes n} F_{3,1}^{(n)} F_{3,2}^{(n)})_{\text{Tr}_{A'_1{}^{\otimes n} A'_2{}^{\otimes n} F_{1,2}^{(n)} F_{1,3}^{(n)}}[\phi_f^{\otimes n} \otimes \tilde{\Phi}_n]} \quad (\text{F4})$$

$$\begin{aligned} & - E_R(B'_1{}^{\otimes n} B'_2{}^{\otimes n} F_{2,1}^{(n)} F_{2,3}^{(n)}; C'_1{}^{\otimes n} C'_2{}^{\otimes n} F_{3,1}^{(n)} F_{3,2}^{(n)})_{\text{Tr}_{A'_1{}^{\otimes n} A'_2{}^{\otimes n} F_{1,2}^{(n)} F_{1,3}^{(n)}}[\mathcal{T}_n(\phi^{\otimes n} \otimes \tilde{\Psi}_n)]} \\ & \geq E_R(B'_1{}^{\otimes n} B'_2{}^{\otimes n} F_{2,1}^{(n)} F_{2,3}^{(n)}; C'_1{}^{\otimes n} C'_2{}^{\otimes n} F_{3,1}^{(n)} F_{3,2}^{(n)})_{\text{Tr}_{A'_1{}^{\otimes n} A'_2{}^{\otimes n} F_{1,2}^{(n)} F_{1,3}^{(n)}}[\phi_f^{\otimes n} \otimes \tilde{\Phi}_n]} \\ & - E_R(B_1{}^{\otimes n} B_2{}^{\otimes n} D_{2,1}^{(n)} D_{2,3}^{(n)}; C_1{}^{\otimes n} C_2{}^{\otimes n} D_{3,1}^{(n)} D_{3,2}^{(n)})_{\text{Tr}_{A_1{}^{\otimes n} A_2{}^{\otimes n} D_{1,2}^{(n)} D_{1,3}^{(n)}}[\phi^{\otimes n} \otimes \tilde{\Psi}_n]}, \end{aligned} \quad (\text{F5})$$

where the second inequality comes from the fact that the relative entropy of entanglement cannot increase under LOCC [9]. It is easy to check that two equalities

$$\text{Tr}_{A_1{}^{\otimes n} A_2{}^{\otimes n} D_{1,2}^{(n)} D_{1,3}^{(n)}}[\phi^{\otimes n} \otimes \tilde{\Psi}_n] = J_{B_1 C_1}^{\otimes n} \otimes J_{B_2 C_2}^{\otimes n} \otimes I_n(2, 1)_{D_{2,1}^{(n)}} \otimes \Psi_{2,3}^{(n)} \otimes I_n(3, 1)_{D_{3,1}^{(n)}}, \quad (\text{F6})$$

$$\text{Tr}_{A_1{}^{\otimes n} A_2{}^{\otimes n} F_{1,2}^{(n)} F_{1,3}^{(n)}}[\phi_f^{\otimes n} \otimes \tilde{\Phi}_n] = I_{B'_2}^{\otimes n} \otimes (|\text{ebit}\rangle\langle\text{ebit}|)_{B'_1 C'_2}^{\otimes n} \otimes I_{C'_1}^{\otimes n} \otimes I'_n(2, 1)_{F_{2,1}^{(n)}} \otimes \Phi_{2,3}^{(n)} \otimes I'_n(3, 1)_{F_{3,1}^{(n)}} \quad (\text{F7})$$

hold. Here, the mixed states J , $I_n(i, j)$, $I'_n(i, j)$, and I are

$$J = \frac{1}{2}(|00\rangle\langle 00| + |11\rangle\langle 11|), \quad I_n(i, j) = \frac{1}{d_{D_{i,j}}^{(n)}} \sum_{j=0}^{d_{D_{i,j}}^{(n)}-1} |j\rangle\langle j|, \quad I'_n(i, j) = \frac{1}{d_{F_{i,j}}^{(n)}} \sum_{j=0}^{d_{F_{i,j}}^{(n)}-1} |j\rangle\langle j|, \quad I = \frac{1}{2}(|0\rangle\langle 0| + |1\rangle\langle 1|), \quad (\text{F8})$$

where $d_{D_{i,j}}^{(n)}$ ($d_{F_{i,j}}^{(n)}$) is the Schmidt rank of the entanglement resource $\Psi_{i,j}^{(n)}$ ($\Phi_{i,j}^{(n)}$) on the quantum systems $D_{i,j}^{(n)}$ ($F_{j,i}^{(n)}$) shared by the i th user and the j th user before (after) performing the QSR protocol \mathcal{T}_n . So we obtain

$$E_R(B_1{}^{\otimes n} B_2{}^{\otimes n} D_{2,1}^{(n)} D_{2,3}^{(n)}; C_1{}^{\otimes n} C_2{}^{\otimes n} D_{3,1}^{(n)} D_{3,2}^{(n)})_{\text{Tr}_{A_1{}^{\otimes n} A_2{}^{\otimes n} D_{1,2}^{(n)} D_{1,3}^{(n)}}[\phi^{\otimes n} \otimes \tilde{\Psi}_n]} \quad (\text{F9})$$

$$\leq nE_R(B_1 B_2; C_1 C_2)_{\text{Tr}_{A_1 A_2}[\phi]} + E_R(D_{2,1}^{(n)} D_{2,3}^{(n)}; D_{3,1}^{(n)} D_{3,2}^{(n)})_{\text{Tr}_{D_{1,2}^{(n)} D_{1,3}^{(n)}}[\tilde{\Psi}_n]} \quad (\text{F10})$$

$$= E_R(D_{2,1}^{(n)} D_{2,3}^{(n)}; D_{3,1}^{(n)} D_{3,2}^{(n)})_{\text{Tr}_{D_{1,2}^{(n)} D_{1,3}^{(n)}}[\tilde{\Psi}_n]}. \quad (\text{F11})$$

In the above, the first inequality comes from the subadditivity [30] of the relative entropy of entanglement. The last equality holds, since $\text{Tr}_{A_1 A_2}[\phi]$ is separable.

By discarding systems $B'_2{}^{\otimes n} F_{2,1}^{(n)}$ and $C'_1{}^{\otimes n} F_{3,1}^{(n)}$, we have

$$E_R(B'_1{}^{\otimes n} B'_2{}^{\otimes n} F_{2,1}^{(n)} F_{2,3}^{(n)}; C'_1{}^{\otimes n} C'_2{}^{\otimes n} F_{3,1}^{(n)} F_{3,2}^{(n)})_{\text{Tr}_{A'_1{}^{\otimes n} A'_2{}^{\otimes n} F_{1,2}^{(n)} F_{1,3}^{(n)}}[\phi_f^{\otimes n} \otimes \tilde{\Phi}_n]} \geq E_R(B'_1{}^{\otimes n} F_{2,3}^{(n)}; C'_2{}^{\otimes n} F_{3,2}^{(n)})_{|\text{ebit}\rangle_{B'_1 C'_2}^{\otimes n} \otimes \Phi_{2,3}^{(n)}}. \quad (\text{F12})$$

In addition, Bob and Charlie can locally prepare the quantum states $I_{B'_2}^{\otimes n} \otimes I'_n(2, 1)_{F_{2,1}^{(n)}}$ and $I_{C'_1}^{\otimes n} \otimes I'_n(3, 1)_{F_{3,1}^{(n)}}$, respectively. It follows that

$$E_R(B'_1{}^{\otimes n} F_{2,3}^{(n)}; C'_2{}^{\otimes n} F_{3,2}^{(n)})_{|\text{ebit}\rangle_{B'_1 C'_2}^{\otimes n} \otimes \Phi_{2,3}^{(n)}} \geq E_R(B'_1{}^{\otimes n} B'_2{}^{\otimes n} F_{2,1}^{(n)} F_{2,3}^{(n)}; C'_1{}^{\otimes n} C'_2{}^{\otimes n} F_{3,1}^{(n)} F_{3,2}^{(n)})_{\text{Tr}_{A'_1{}^{\otimes n} A'_2{}^{\otimes n} F_{1,2}^{(n)} F_{1,3}^{(n)}}[\phi_f^{\otimes n} \otimes \tilde{\Phi}_n]}. \quad (\text{F13})$$

From the fact that $E_R(X; Y)_\rho = H(X)_\rho$ holds for any pure state ρ_{XY} , we have

$$E_R(B'_1{}^{\otimes n} F_{2,3}^{(n)}; C'_2{}^{\otimes n} F_{3,2}^{(n)})_{|\text{ebit}\rangle_{B'_1 C'_2}^{\otimes n} \otimes \Phi_{2,3}^{(n)}} = H(B'_1{}^{\otimes n} F_{2,3}^{(n)})_{I_{B'_2}^{\otimes n} \otimes I'_n(2,3)_{F_{2,3}^{(n)}}} = n + \log d_{F_{2,3}^{(n)}}. \quad (\text{F14})$$

Similarly, we have

$$E_R(D_{2,1}^{(n)} D_{2,3}^{(n)}; D_{3,1}^{(n)} D_{3,2}^{(n)})_{\text{Tr}_{D_{1,2}^{(n)} D_{1,3}^{(n)}}[\tilde{\Psi}_n]} = \log d_{D_{2,3}^{(n)}}. \quad (\text{F15})$$

By using Eqs. (F9), (F14), and (F15), Eq. (F5) becomes

$$2\delta_n \log d_{B'_1 B'_2 C'_1 C'_2} + \frac{\delta_n}{n} (2 \log d_{F_{2,1}^{(n)} F_{2,3}^{(n)} F_{3,1}^{(n)} F_{3,2}^{(n)}} - 2 \log \delta_n + 4) + \frac{1}{n} (\log d_{D_{2,3}^{(n)}} - \log d_{F_{2,3}^{(n)}}) \geq 1. \quad (\text{F16})$$

As $n \rightarrow \infty$, this inequality becomes $0 = e_{2,3}(\phi, \{\mathcal{T}_n\}) \geq 1$, which is a contradiction. Therefore, it is impossible to transform two GHZ states shared by Alice, Bob, and Charlie into three ebits symmetrically shared among them via LOCC, even under the catalytic use of entanglement resource.

If we consider a nonasymptotic scenario in which users begin this transformation with finite copies of the initial states, whether the transformation is possible or not under the nonasymptotic scenario with the catalytic use of entanglement is unknown, to the best of our knowledge.

-
- [1] C. H. Bennett, G. Brassard, C. Crépeau, R. Jozsa, A. Peres, and W. K. Wootters, *Phys. Rev. Lett.* **70**, 1895 (1993).
- [2] M. Horodecki, J. Oppenheim, and A. Winter, *Nature (London)* **436**, 673 (2005).
- [3] M. Horodecki, J. Oppenheim, and A. Winter, *Commun. Math. Phys.* **269**, 107 (2006).
- [4] I. Devetak, *Phys. Rev. Lett.* **97**, 140503 (2006).
- [5] J. Oppenheim, [arXiv:0805.1065](https://arxiv.org/abs/0805.1065).
- [6] I. Devetak and J. Yard, *Phys. Rev. Lett.* **100**, 230501 (2008).
- [7] J. T. Yard and I. Devetak, *IEEE Trans. Inf. Theory* **55**, 5339 (2009).
- [8] A. Abeyesinghe, I. Devetak, P. Hayden, and A. Winter, *Proc. R. Soc. A* **465**, 2537 (2009).
- [9] M. M. Wilde, *Quantum Information Theory* (Cambridge University Press, Cambridge, U.K., 2013).
- [10] J. Oppenheim and A. Winter, [arXiv:quant-ph/0511082](https://arxiv.org/abs/quant-ph/0511082).
- [11] Y. Lee, R. Takagi, H. Yamasaki, G. Adesso, and S. Lee, *Phys. Rev. Lett.* **122**, 010502 (2019).
- [12] Y. Lee, H. Yamasaki, G. Adesso, and S. Lee, *Phys. Rev. A* **100**, 042306 (2019).
- [13] C. H. Bennett, H. J. Bernstein, S. Popescu, and B. Schumacher, *Phys. Rev. A* **53**, 2046 (1996).
- [14] C. H. Bennett, D. P. DiVincenzo, J. A. Smolin, and W. K. Wootters, *Phys. Rev. A* **54**, 3824 (1996).
- [15] C. H. Bennett, G. Brassard, S. Popescu, B. Schumacher, J. A. Smolin, and W. K. Wootters, *Phys. Rev. Lett.* **78**, 2031(E) (1997).
- [16] B. Schumacher, *Phys. Rev. A* **51**, 2738 (1995).
- [17] D. M. Greenberger, M. A. Horne, and A. Zeilinger, *Bell's Theorem, Quantum Theory, and Conceptions of the Universe* (Kluwer Academic, Dordrecht, Netherlands, 1989).
- [18] C. H. Bennett, S. Popescu, D. Rohrlich, J. A. Smolin, and A. V. Thapliyal, *Phys. Rev. A* **63**, 012307 (2000).
- [19] N. Linden, S. Popescu, B. Schumacher, and M. Westmoreland, *Quantum Inf. Process.* **4**, 241 (2005).
- [20] J. I. Cirac, A. K. Ekert, S. F. Huelga, and C. Macchiavello, *Phys. Rev. A* **59**, 4249 (1999).
- [21] D. Bruß, G. M. D'Ariano, M. Lewenstein, C. Macchiavello, A. Sen(De), and U. Sen, *Phys. Rev. Lett.* **93**, 210501 (2004).
- [22] J. I. Cirac, P. Zoller, H. J. Kimble, and H. Mabuchi, *Phys. Rev. Lett.* **78**, 3221 (1997).
- [23] K. Azuma, A. Mizutani, and H.-K. Lo, *Nat. Commun.* **7**, 13523 (2016).
- [24] M. Fannes, *Commun. Math. Phys.* **31**, 291 (1973).
- [25] K. M. R. Audenaert, *J. Phys. A* **40**, 8127 (2007).
- [26] A. Anshu, R. Jain, and N. A. Warsi, *IEEE Trans. Inf. Theory* **64**, 1436 (2018).
- [27] N. Dutil and P. Hayden, [arXiv:1011.1974](https://arxiv.org/abs/1011.1974).
- [28] W. van Dam and P. Hayden, [arXiv:quant-ph/0204093](https://arxiv.org/abs/quant-ph/0204093).
- [29] M. J. Donald and M. Horodecki, *Phys. Lett. A* **264**, 257 (1999).
- [30] K. G. H. Vollbrecht and R. F. Werner, *Phys. Rev. A* **64**, 062307 (2001).