

TABLE II. Relative probability of emission of n pions in a collision of two nucleons for $\xi=2$.

n	0	1	2	3	4	\bar{n}
3	1	11	88	9	63	1.87
5			9	63	28	3.2

The angular distribution as modified by the null-point energy will be taken up in a subsequent paper, but it is interesting to observe that the existence of null-point energy puts an upper limit on the number of particles produced during a high energy nucleon collision.

¹ E. Fermi, *Progr. Theoret. Phys.* **5**, 570 (1950).

² The effect of the zero-point energy of the nucleons is ignored here.

Pion Production Ratios by Proton Bombardment

RYOKICHI SAGANE

Radiation Laboratory, Department of Physics, University of California, Berkeley, California

(Received April 16, 1953)

RATIOS of π^+ - to π^- -production at 90° , preliminarily reported earlier,¹ for six elements at 13 Mev, 18 Mev, and 42 Mev are listed in Table I.

TABLE I. π^+/π^- ratios at 90° .^a

	Number		Number		Number				
	13 Mev ± 3		18 Mev ± 3		42 Mev ± 2				
	π^-	π^+	π^-	π^+	π^-	π^+			
Pb	0.47 ± 0.1	84	134	1.2 ± 0.6	28	17	4.8 ± 2.5	88	13
Ag	0.70 ± 0.15	75	81	1.25 $\pm 0.5^b$	26	15	4.8 ± 1.5	(Sn)169	25
Cu	2.0 ± 0.4	197	72	1.95 ± 0.5	96	37	8.3 ± 2.5	254	22
Al	2.5 $\pm 0.8^b$	217	61	4.3 ± 0.8	656	110	10.5 $\pm 2.0^b$	463	31
C	1.95 ± 0.4	217	86	5.3 $\pm 0.8^b$	556	76	11.0 ± 1.5	1091	72
Be	1.45 $\pm 0.3^b$	141	77	5.1 $\pm 0.9^b$	496	69	6.4 ± 1.0	815	92

^a Detection efficiencies for π^+ - and π^- -stars (one or more prongs) were assumed as 90 percent and 97 percent, respectively. Probability for stars with one or more prongs (neglecting clubs) was measured to be 69 percent.

^b Single run measurements.

The spiral orbit spectrometer² (2π -angular focusing of charged particles originating on the axis with the use of an axially symmetric heterogeneous magnetic field) was used to focus mesons of a given energy close to the so-called "stable orbit." The 340-Mev proton beam deflected out from the cyclotron was passed through a $1\frac{1}{2}$ -in. i.d. hole on the axis of the 20-in. o.d. pole pieces of a large electromagnet. Focusing of 8-Mev pions was obtained with $2\frac{3}{8}$ -in. gap and 13-Mev pions with a $1\frac{1}{8}$ -in. gap. Energy loss through the target material was more significant for the energy spread than the resolution of the spectrometer. As a result, these settings corresponded to average energies of 13 Mev and 18 Mev, respectively. Use of a tubular absorber (10-mm wall, Cu) at the 8-Mev setting made possible the detection of 42-Mev mesons.

C2, 200 μ Ilford plates were used as detectors. A pair of 3-in. \times 1-in. plates were put together with emulsion side face to face. Copper foils of proper thicknesses were added in the back of each plate. The plates were mounted behind the radiation shield with surfaces perpendicular to the incoming mesons, as shown in Fig. 1.

Since the focusing conditions were quite symmetric for mesons of both signs, positive and negative mesons coming from opposite directions were stopped in the same portion of the emulsion after passing through the glass plates.

As predicted from the theory of the spiral orbit spectrometer, the effect of vertical focusing for the case of the 8-Mev setting worked very favorably. Although the resolving power of the spectrometer itself ($\pm 3 - \pm 5$ percent in $H\rho$) was too good and caused a loss by a factor 2-5, the angular focusing of about 300° (corrected for lifetime) and the gain by the vertical focusing resulted

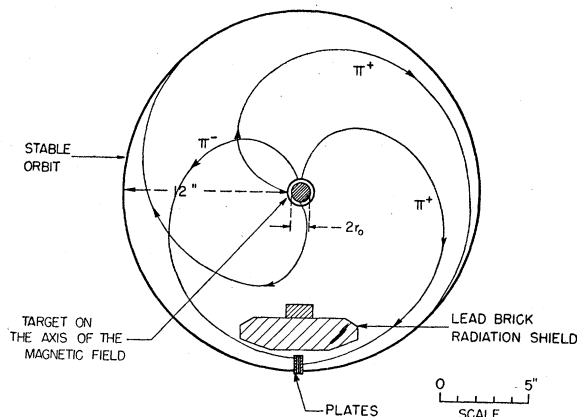

FIG. 1. Experimental arrangement (spiral orbit spectrometer).

in a gain of a factor 20-600, compared with the usual deflection method.

A rough computation of relative cross sections for 42-Mev π^+ -mesons was also made. This preliminary result showed a curve proportional to Z^3 . A more accurate experiment on Z dependence is now going on. Experimental details will be reported in University of California Research Laboratory Report UCRL-2161.

The author is grateful to Dr. W. Powell for the use of the magnet and to Dr. W. Barkas for his continuous interest and help throughout the work.

¹ R. Sagane and P. C. Giles, *Phys. Rev.* **81**, 653 (1951); R. Sagane, *Bull. Am. Phys. Soc.* **27**, No. 6, 17 (1952).

² G. Miyamoto, *Proc. Phys.-Math. Soc. Japan* **24**, 676 (1942); *Proc. Phys.-Math. Soc. Japan* **17**, 587 (1943); M. Sakai, *J. Phys. Soc. Japan* **5**, 178 (1950); R. Sagane and W. Gardner, University of California Radiation Laboratory, Trans. 111 (1951), (unpublished).

Calculation of Nuclear Binding Energies with Single-Particle Oscillator Wave Functions

ERWIN H. KRONHEIMER

Department of Mathematics, University of Southampton, Southampton, England

(Received April 6, 1953)

PEASE and Feshbach^{1,2} recently proposed a neutral phenomenological interaction,

$$-V_0\left\{\left[1-\frac{1}{2}g+\frac{1}{2}g\sigma_1\cdot\sigma_2\right]f(r_{12}/r_c)+\gamma S_{12}f(r_{12}/r_i)\right\}; \quad (1)$$

where

$$S_{12} = r_{12}^{-2} [3(\sigma_1 \cdot r_{12})(\sigma_2 \cdot r_{12}) - \sigma_1 \cdot \sigma_2],$$

$$f(x) = e^{-x}/x, \quad r_{12} = r_2 - r_1,$$

which was fitted to the singlet potential, the deuteron quadrupole moment and binding energy, and the binding energy of H^3 , and was found to predict the triplet effective range satisfactorily. Irving³ showed that it also gives the correct binding energy of He^4 .

Although it is well known that a neutral interaction cannot give saturation of binding energy for heavy nuclei, a calculation by the methods of Jahn⁴ and Elliott⁵ with single-particle oscillator-well wave functions, using this interaction, has shown that it predicts a large excess of binding already for Be^9 . In this calculation only the lowest (2P) state of highest orbital symmetry of the $(1s)^4(2p)^5$ configuration, with a single oscillator-parameter ν [so that $\psi_i(1s) \sim \exp(-\frac{1}{2}\nu r_i^2)$, $\psi_j(2p) \sim r_j \exp(-\frac{1}{2}\nu r_j^2)$], was needed to yield 109-Mev binding (after allowing for Coulomb repulsion), compared with the actual figure of 58 Mev. (The constants used were $V_0 = 46.1$ Mev, $g = -0.004$, $r_c = 1.184 \times 10^{-13}$ cm;¹ the tensor force does not couple a doublet state to itself and is not involved.)

If the interaction (1) is changed to the corresponding charge-