

tion. The evaluation of the efficiency of the chamber for these groups was calculated by means of the formula of Bethe and Peierls.

We must also keep in mind the possibility of an emission of D+D neutrons due to a deuterium contamination of the target surface. This objection seems to be ruled out by our conditions being similar to those of Bonner and Brubaker, who observed only a negligible number of neutrons corresponding to the D+D reaction. It appears moreover, unlikely that a red hot graphite target, under a pressure of 7×10^{-5} mm, as in the tube during our experiments, could adsorb an amount of deuterium (of the order of one-tenth of one percent within the effective thickness of the target) sufficient to give an average cross section of the order of the one observed by us.

Finally, the possible explanation that our small value of the cross section is due to an admixture of neutrons of higher energies does not appear to be consistent with the exponential form of the scattering curve.

A similar result was found by Goldhaber² using photoneutrons. The value (from 3.7 to 4.7×10^{24}) found by Tuve and Hafstad⁴ for the neutrons from the C+D reaction appears to be also somewhat lower than theoretically expected. Instead, Leipunski, Rosenkewitsch and Timoshuk,³ using photoelectric neutrons of 0.15 Mev energy, found the theoretically expected value.

We intend to investigate further this point in order to understand why the scattering cross section in hydrogen in our experiments was much smaller than we expected.

NOVEMBER 1, 1939

PHYSICAL REVIEW

VOLUME 56

Effects of Shape of Potential Energy Wells Detectable by Experiments on Proton-Proton Scattering

L. E. HOISINGTON, S. S. SHARE AND G. BREIT
University of Wisconsin, Madison, Wisconsin

(Received September 5, 1939)

The shapes of several types of potential wells giving approximate agreement with proton-proton scattering experiments are discussed. The somewhat poor agreement of the K_0 , E curve for the exponential well with experimental data is shown to be due to the "tail" of the well at large radii. In the case of the meson potential well the effect of very large values of the potential at small distances counteracts the effect of the tail. The experimental dependence of phase shift on energy is not reproduced by the inverse square potential well. The maximum theoretically admissible depth of this potential fits experiment at about 1 Mev. A series expansion is developed which gives the change of the phase shift caused by a given change in the potential well, and an example of the use of the formula is given. The approximate equality of the proton-proton and proton-neutron interactions is discussed, and the close agreement in the case of the meson potential is shown to be due to the large attraction at small distances.

THE first experiments¹ on the scattering of protons by protons determined the s -wave anomaly in the energy range 600–900 kev and have indicated the rather close equality of the proton-proton and proton-neutron interactions on the assumption of the same shape of potential

well.² The energy range covered was insufficient, however, to determine the range of force except very qualitatively and the shape of the nuclear potential curve was also left quite undetermined. The newer experiments³ have increased the energy region in which the s anomaly is known

¹ W. H. Wells, Phys. Rev. **47**, 591 (1935); M. G. White, Phys. Rev. **47**, 573 (1935); M. A. Tuve, N. P. Heydenburg and L. R. Hafstad, Phys. Rev. **49**, 402 (1936); **50**, 806 (1936); L. R. Hafstad, N. P. Heydenburg and M. A. Tuve, Phys. Rev. **51**, 1023 (1937); **53**, 239 (1938).

² G. Breit, E. U. Condon and R. D. Present, Phys. Rev. **50**, 842 (1936).

³ R. G. Herb, D. W. Kerst, D. B. Parkinson and G. J. Plain, Phys. Rev. **55**, 998 (1939); N. P. Heydenburg, L. R. Hafstad and M. A. Tuve, Phys. Rev. **55**, 603(A) (1939). For analysis of data see BTE, pp. 1035–36.

and have also increased the precision. For some assumed potential energy curves of fixed shape but adjustable width and depth, one finds now disagreement between theoretical and experimental values even though width and depth are adjusted to represent experiment at two energies. It is possible to distinguish between different shapes of potential energy curves, and the present note is intended to show some examples illustrative of the features in the shape which may cause experimentally observable effects. For relativistic reasons it is impossible to believe in a potential energy well as an ultimate description of the interaction and the wells which agree with experiment are not necessarily advocated as having a fundamental significance. It will be seen, however, that the meson potential agrees satisfactorily with experiment, and among the potentials tried is the only one giving agreement of proton-proton and proton-neutron interactions

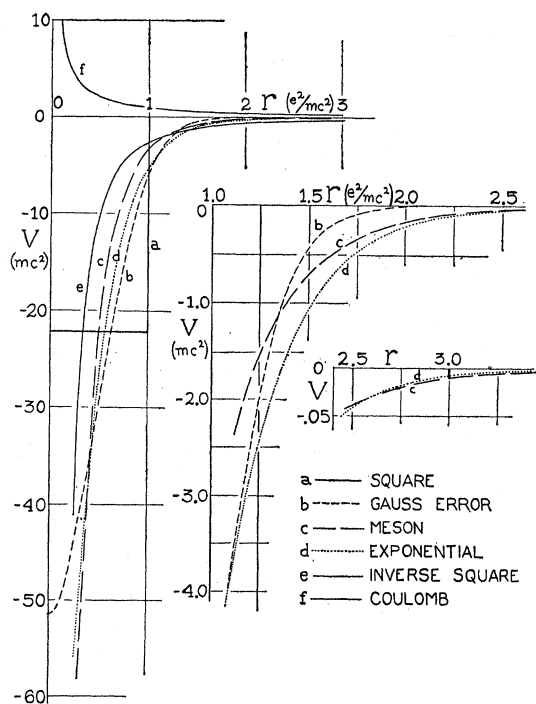

FIG. 1. Potential energy in mc^2 plotted against the radius in e^2/mc^2 for the following: (a) square well of depth $22.15 mc^2$ and width e^2/mc^2 , (b) Gauss error well $Ae^{-\alpha r^2}$ where $A = 51.44 mc^2$ and $\alpha = 21.59 Mmc^2/\hbar^2$, (c) meson well $Ce^{-r/a}/(r/a)$ where $C = 89.65 mc^2$ and $a = 0.42 e^2/mc^2$, (d) exponential well $Be^{-2r/b}$ where $B = 137.6 mc^2$ and $b = 0.193 \hbar(Mmc^2)^{-1/2}$, (e) inverse square well B/r^2 where $B = \frac{1}{4}$ and (f) the Coulomb potential. The "tails" are shown in the two smaller insets.

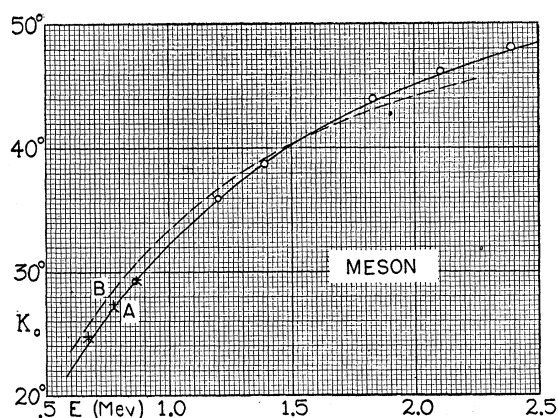

FIG. 2. Phase shift K_0 plotted against the energy of the incident protons, for the meson potential well, $Ce^{-r/a}/(r/a)$. A , $C = 89.65 mc^2$, $a = 0.42 e^2/mc^2$ (this corresponds to a meson mass of $326 m$). B , $C = 34.15 mc^2$, $a = \frac{2}{3} e^2/mc^2$ (corresponding to a meson mass of $206 m$). The potential $-Ce^{-r/a}/(r/a)$ is superposed on the Coulomb potential. Points \odot correspond to the data of Herb, Kerst, Parkinson and Plain, points $+$ to the data of Heydenburg, Hafstad and Tuve (see BTE⁶, pp. 1035-6), and points \triangle to the data of HHT as analyzed by Mr. E. C. Creutz using least squares in work to be published shortly.

to within the accuracy of scattering experiments.

In Fig. 1 are shown potential energy curves for (a) square well of depth $22.15 mc^2$ and range e^2/mc^2 , (b) Gauss error potential well $Ae^{-\alpha r^2}$ where $A = 51.44 mc^2$ and $\alpha = 21.59 Mmc^2/\hbar^2$, (c) meson,⁴ $Ce^{-r/a}/(r/a)$ where $C = 89.65 mc^2$, $a = 0.42 e^2/mc^2$, (d) exponential⁵ potential well $Be^{-2r/b}$ where $B = 137.6 mc^2$, $b = 0.193 \hbar(Mmc^2)^{-1/2}$, and (e) inverse square B/r^2 with $B = \hbar^2/4M$. All potential wells except (a) are cut off at $r = 3e^2/mc^2$ and in all cases the potentials are supposed to be superposed on the Coulombian potential (f). The potentials in this figure are chosen so as to represent the data approximately. It is seen from the figure that the potentials (b), (c), (d) are not very different from $r = 0.5$ to $r = 1.25 e^2/mc^2$. The square well intersects each of the other three curves twice also in the same region. The values of the depth at $r = 0$ are quite different in the four cases, covering a range from $22.15 mc^2$ to ∞ . These values of depth have no direct simple significance since ξ (r times the radial wave function) is too small close to $r = 0$.

In Figs. 2 and 3 the phase shift (K_0) is plotted against energy for the potentials (c) and (d).

⁴ S. S. Share, L. E. Hoisington and G. Breit, Phys. Rev. **55**, 1130(A) (1939).

⁵ W. Rarita and R. D. Present, Phys. Rev. **51**, 793 (1937).

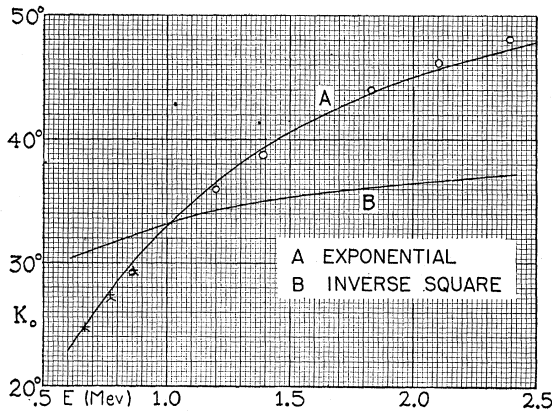

FIG. 3. Phase shift K_0 plotted against the energy of the incident protons. *A*, for the exponential well $Be^{-2r/b}$, where $B=137.6 mc^2$ and $b=0.193 \hbar(Mmc^2)^{-1/2}$. *B*, for the inverse square well, B/r^2 , where $B=\frac{1}{2}$. Each well is superposed on the Coulomb potential. Points \circ , $+$ and Δ are as in Fig. 2.

(For (a) and (b) see Fig. 10 of BTE.)⁶ It is seen in Fig. 3 that the exponential potential gives relatively too high values of K_0 at 1200 kev and too low values at 2400 kev even though it is fitted to experiment at 670 kev. At 1200 kev K_0 is too high by $\sim 0.7^\circ$, which amounts to ~ 5 percent of the measured scattering at a scattering angle of 45° . At 2400 kev the deviation of -0.7° in K_0 corresponds to ~ -3 percent of the scattering at 45° . The consistency with which the experimental curve deviates from that calculated for the exponential potential is striking. To explain it one would need to assume a systematic error varying suitably with energy. The disagreement could be decreased by fitting the potential to intersect the experimental curve at a higher energy than 670 kev. The fit of the square and the Gauss error potentials (a) and (b) (Fig. 10 of BTE⁶) is seen, however, to be practically as good as that of the exponential well at 700 kev and much better at higher energies. The deviation from experiment for the exponential potential is due to a too high curvature of the theoretical K_0, E curve, and a change in range affects primarily the slope rather than the curvature.

The depth and width of the exponential well used here are those obtained by Rarita and Present.⁵ It is remarkable that this potential agrees approximately with proton-proton scattering up to 2400 kev as well as with the binding

energies of H^3 and H^2 . Yet it does not agree⁵ with the energy of He^4 . The comparison of curve *A* of Fig. 3 with curve *A* of Fig. 2 is not quite fair to the exponential potential because in Fig. 2 the experimental point at 670 kev lies above the theoretical curve.

The qualitative explanation of the difference in shape of the K_0, E curve for the exponential potential as compared with the Gauss error or square well potentials lies in the fact that the exponential potential has a "tail." As can be seen in Fig. 1, this potential well (d) is deeper than the Gauss error well (b) for $r > 1.1 e^2/mc^2$ and is appreciable even out to $r = 3 e^2/mc^2$. But the function \mathfrak{F} differs little for the three wells (a) (b) and (d), and the first-order effect due to a small change of potential at a given distance is proportional to $\mathfrak{F}^2 E^{-1/2}$ (see Eq. (3)). Curves of $\mathfrak{F}^2 E^{-1/2}$ plotted against E are shown in Fig. 4(a). Up to 1 Mev \mathfrak{F} increases so rapidly with energy that $\mathfrak{F}^2 E^{-1/2}$ also does the same, but above 1 Mev the slope is seen to be negative for the larger radii. Thus the effect of increasing the proton-proton attraction at a distance of about $2 e^2/mc^2$ is to increase K_0 by a larger amount at lower energies than at 2.6 Mev. Therefore when a potential well is fitted to data at approximately 1 Mev, the tail makes it unnecessary to use as large a depth as one would if it were not present. There is, therefore, less dependence of K_0 on energy of the type shown by the curve labeled $r=0.5$ and more of the type shown in the curve labeled $r=3$ in Fig. 4(a). The negative slope of the $r=3$ curve gives a smaller slope of the K_0, E curve above 1 Mev as the result of the tail.

The increase in slope at low energies can also be seen from the sensitivity curves as well as from the fact that the tail when extending to the outskirts of the Coulomb barrier should give a rapid increase of K_0 with E somewhat below that energy at which barrier penetration becomes unimportant. The result of the increase in slope below 1 Mev and decrease above 1 Mev is the bulge in the phase shift curve around 1.4 Mev which is apparent in Fig. 3 for the potential (d) and which is responsible for the disagreement with experiment.

The meson potential (c) has a tail which is similar to that of the exponential potential (d), as is seen in Fig. 1. The bulge at intermediate

⁶ G. Breit, H. M. Thaxton and L. Eisenbud, Phys. Rev. 55, 1057 (1939).

energies is absent, however. This is due to the rather large values of the potential energy for (c) at radii smaller than $e^2/2mc^2$. For these small distances the slope of $\mathfrak{F}^2 E^{-\frac{1}{2}}$ against E remains nearly constant from 1 Mev to higher energies, while for $r > e^2/mc^2$ the slope in this energy region becomes negative. Increasing the attraction at small distances decreases the bulge of the K_0, E curve which is present for the exponential well. These considerations are only approximate, since they neglect the distortion of the wave function due to large interactions at small r for well (c). The main effect of this distortion is to change the relative scale of curves for different r in Fig. 4(a) which does not affect the above qualitative argument.

For the well (e) of type B/r^2 (potential energy $= -B/r^2$) there are again compensating effects of tail and large values at small distances. In this case there is no exponential decrease of depth with distance. The phase shift can be computed⁷ analytically as the argument of a gamma-function. For $B < +\hbar^2/4M$ there is no regular solution of the equation for \mathfrak{F} so that \mathfrak{F} is undefined. The singularity is then too strong. For $B = +\frac{1}{4}$ nuclear units (i.e., $+\hbar^2/4M$ in c.g.s. units) the solution \mathfrak{F} and K_0 can be defined. The K_0, E graph corresponding to this is shown in Fig. 3. The order of magnitude is correct through most of the experimental region. The slope of the K_0, E curve is too small, however. The effect of the tail is seen to be predominant. In the absence of a Coulomb potential the phase shift is independent of energy, the asymptotic form of the regular solution of $\{d^2/d\rho^2 + [1 - L(L+1)/\rho^2]\}\mathfrak{F} = 0$ being $\sin(\rho - L\pi/2)$. The value $B = +\frac{1}{4}$ nuclear units corresponds to $L = -\frac{1}{2}$ and in this case would give $K_0 = \pi/4$ at all energies. In the absence of Coulomb field the solution for \mathfrak{F} becomes const. $\rho^{\frac{1}{2}}J_0(\rho)$ and an irregular solution is const. $\rho^{\frac{1}{2}}Y_0(\rho)$. The irregular solution has only a logarithmic singularity at $\rho = 0$ and the distinction between regular and irregular solutions appears to be only artificial in this case.⁸ One should require, however, that $\mathfrak{F}^2 \rho^{-2}$ be integrable at $\rho = 0$. Since for small ρ one has $\mathfrak{F} \sim \text{const. } \rho^{L+1}$

⁷ We understand that unpublished calculations with this potential have been made in a thesis with Professor Hoyt at the University of Chicago.

⁸ N. F. Mott and H. S. W. Massey, *The Theory of Atomic Collisions* (Oxford, 1933), p. 30.

it is necessary for ρ^{2L+1} to be finite at $\rho = 0$, so that $L > -\frac{1}{2}$.

EXPANSION SHOWING EFFECTS OF LOCAL CHANGES IN POTENTIAL

The explanation of the effect of the tail has been tested by using an expansion for K_0 in terms of a small change in potential which will be called δV . The differential equation is

$$(d^2/d\rho^2 + 1 - V/E' - \lambda\delta V/E')\mathfrak{F} = 0.$$

The quantities $V, \delta V$ are functions of ρ and the phase shift is expanded in powers of λ . The solution \mathfrak{F} is supposed to be known for $\lambda = 0$, and the value of the phase shift K_0 for $\lambda = 0$ is also supposed to be known. For the higher order corrections one needs also the irregular solution \mathfrak{G} of the above differential equation. \mathfrak{F} and \mathfrak{G} are supposed to be normalized to unit amplitude at

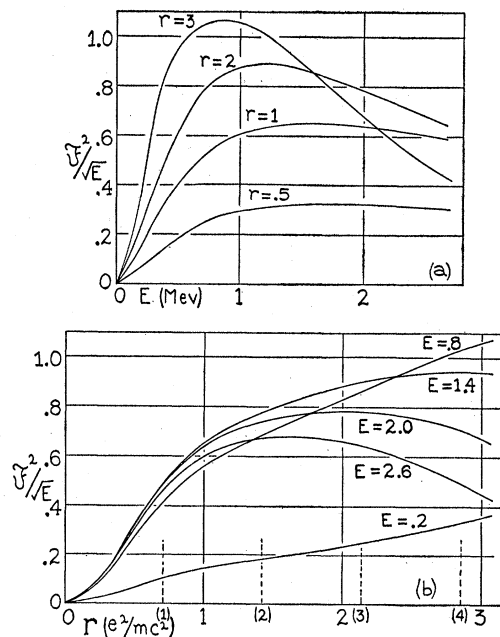

FIG. 4. (a) $\mathfrak{F}^2 E^{-\frac{1}{2}}$ plotted for different radii as a function of energy of the incident protons. (b) $\mathfrak{F}^2 E^{-\frac{1}{2}}$ plotted for different energies as a function of the radius. The small numbers in parentheses along the r axis in (b) give the values of $x = (20 Mmc^2/\hbar^2)^{\frac{1}{2}} r$. E is in Mev and r is in e^2/mc^2 . \mathfrak{F} is for the Gauss error potential $Ae^{-\alpha r^2}$ where $A = 47.17 mc^2$ and $\alpha = 20 Mmc^2/\hbar^2$. $\mathfrak{F}^2 E^{-\frac{1}{2}}$ at any radius measures the sensitivity of the phase shift K_0 to a change in potential at that radius. These sensitivity curves are not changed much if other potentials, fitting experiment approximately, are used for calculating \mathfrak{F} because \mathfrak{F} is approximately determined by K_0 .

$\rho = \infty$ and the phase of \mathcal{G} is $\pi/2$ plus the phase of \mathcal{F} . Because of λ there is an addition to the phase shift which will be called δK . It is found that

$$\tan(\delta K) = -\mathcal{F}^2[\lambda y_\lambda + \lambda^2(y_{\lambda\lambda}/2 - \mathcal{F}\mathcal{G}y_\lambda^2) + \lambda^3(y_{\lambda\lambda\lambda}/6 - \mathcal{F}\mathcal{G}y_\lambda y_{\lambda\lambda} + \mathcal{F}^2\mathcal{G}^2y_\lambda^3) + \dots], \quad (1)$$

where

$$y = d\mathcal{F}/d\rho$$

and successive differentiation of y with respect to λ is denoted by suffixes. In the differentiation \mathcal{F} is supposed to be varied with λ . Considering \mathcal{F} and \mathcal{G} as $\mathcal{F}(\lambda, \rho)$, $\mathcal{G}(\lambda, \rho)$ the values in Eq. (1) are $\mathcal{F}(0, \rho)$, $\mathcal{G}(0, \rho)$, and similarly y_λ , $y_{\lambda\lambda}$, \dots are evaluated for $\lambda=0$. To derive the formula it is sufficient to remember that the phase shift δK can be computed with reference to K by exactly the same procedure as K can be computed with reference to the phase existing in the absence of the nuclear potential (the latter is part of V); only \mathcal{F} , \mathcal{G} should be used instead of the Coulomb functions F , G and the quantity $dF/Fd\rho - d\mathcal{F}/\mathcal{F}d\rho$ should be replaced by $d\mathcal{F}/\mathcal{F}d\rho - d\mathcal{F}_m/\mathcal{F}_m d\rho$, where \mathcal{F}_m is \mathcal{F} modified by using $V + \lambda\delta V$ instead of V . This difference in logarithmic derivatives when expanded into Taylor's series in λ gives Eq. (1). The quantities y_λ , $y_{\lambda\lambda}$, \dots can be evaluated by means of Eqs. (9.1) of BTE⁶ by substituting ρ for x , $-\delta V/E'$ for φ and \mathcal{F} for F . With the abbreviation

$$-\mathcal{F}^2 y_\lambda = I(\rho) = -\int_0^\rho (\delta V \mathcal{F}^2 E'^{-1}) d\rho,$$

the expansion (1) becomes

$$\begin{aligned} \tan \delta K = & \lambda I + \lambda^2 \left(\int_0^\rho \mathcal{F}^{-2} I^2 d\rho + \mathcal{G} I^2 / \mathcal{F} \right) \\ & + \lambda^3 \left(2 \int_0^\rho \mathcal{F}^{-2} I \left[\int_0^\rho \mathcal{F}^{-2} I^2 d\rho \right] d\rho \right. \\ & \left. + 2 \mathcal{G} \mathcal{F}^{-1} I \left[\int_0^\rho \mathcal{F}^{-2} I^2 d\rho \right] + \mathcal{G}^2 I^3 / \mathcal{F}^2 \right) + \dots \quad (2) \end{aligned}$$

The first term is essentially Taylor's approximation. The second represents the effect of the distortion of the wave function on the first-order effect. The expansion converges rapidly if the distortion of the wave function is not too large. It applies for all L and can be used for other

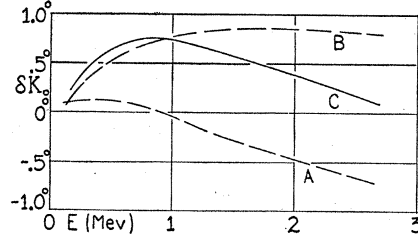

FIG. 5. The changes in phase shift K_0 caused by changing from the Gauss error potential $Ae^{-\alpha r^2}$ where $A=47.17 mc^2$ and $\alpha=20 Mmc^2/\hbar^2$ to the exponential potential $Be^{-2r/b}$ where $B=137.6 mc^2$ and $b=0.193 \hbar(Mmc^2)^{-1/2}$ as calculated by Eq. (2). *A*, first-order effect; *B*, second-order effect; *C*, the sum of first- and second-order effects.

phase shifts than those in proton-proton scattering.

For proton-proton scattering the first-order effect becomes, for $\lambda=1$,

$$\delta K = -0.618 \int_0^r \delta V \mathcal{F}^2 E^{-1/2} d(rmc^2/e^2), \quad (3)$$

where δV and E are in Mev.

The above expansion was used to compute K_0 for the exponential potential (d) using numerical integrations for the Gauss error potential $Ae^{-\alpha r^2}$ with $A=47.17 mc^2$, $\alpha=20 Mmc^2/\hbar^2$. The results were compared with direct calculations for the exponential potential. The latter were made by numerical integration of the differential equation at 600, 1400 kev and expansion of y by Eqs. (9.1) of BTE as a function of E , the results inter-checking in the overlapping region. These calculations for the exponential potential differ from those obtained by the expansion (1) by 0.01° at 800 kev, 0.02° at 1400 kev, -0.01° at 2000 kev, and 0.01° at 2600 kev. At 200 kev the difference is larger and is 0.07° . In Fig. 5 the first- and second-order effects are represented graphically. The second-order effect is practically constant from 800-2600 kev and the first-order effect gives a fair idea of the change in shape of the K_0, E , curve in this region.

COMPARISON OF THE PROTON-PROTON AND PROTON-NEUTRON INTERACTIONS

The experiments on proton-proton scattering and the older experiments on proton-neutron scattering⁹ indicated that the proton-neutron

⁹ V. W. Cohen, H. H. Goldsmith and J. Schwinger, Phys. Rev. 55, 106(L) (1939).

interaction was a little stronger than that between two protons; that is, if the two interactions were considered as due to the same shape and range of potential well, the proton-neutron interaction required a slightly greater depth. Although this difference was small, it was definitely outside the apparent limits of experimental error. The newer experiments,¹⁰ however, have given a lower proton-neutron cross section. The required difference in depth changed¹¹ to about 1.5 percent for the square and Gauss error wells and corresponds to a difference of $\sim 4 \times 10^{-24}$ cm² in a total slow neutron-proton scattering cross section of $\sim 15 \times 10^{-24}$ cm².

In the case of the meson well, however, the difference is within experimental error. Simons' value for the proton-neutron scattering cross section $\sigma_{\pi n}$ is 14.8×10^{-24} cm² so that $\sigma_{\text{th}} = 59.2 \times 10^{-24}$ cm², and assuming $12 \pi a_3^2 = 12.9 \times 10^{-24}$, this gives 46.3×10^{-24} cm² = $4 \pi a_1^2$. (For notation see BTE.)* The best fit to proton-proton data was obtained for the meson well $Ce^{-r/a}/(r/a)$ where $C = 89.65 mc^2$ and $a = 0.42 e^2/mc^2$. By numerical integration it was found that for these values of C and a $4\pi a_1^2 = 43.85 \times 10^{-24}$ cm². The value of $12\pi a_3^2$ was not calculated for the meson well, but this quantity does not change much with change of type of potential, so the value 12.9×10^{-24} cm² found for the square well (BTE p. 1057) was used. This gives $\sigma_{\text{th}} = 56.7 \times 10^{-24}$ cm², which agrees with the experimental value 59.2×10^{-24} cm² to within the experimental error.

Numerical integrations to find \mathfrak{F} were made for the meson wells with $a = 0.42 e^2/mc^2$ and $C = 89.648, 91.020, \text{ and } 92.696 mc^2$. These integrations gave values of $4\pi a_1^2$ equal to 43.85, 65.38, and 122.87×10^{-24} cm², respectively. If C is plotted against $(4\pi a_1^2)^{-1/2}$, the resulting curve is almost a straight line, and it is easy to see what value of C is required to give $4\pi a_1^2 = 46.3 \times 10^{-24}$ cm², which is expected from Simons' experiments. The required value of C is only 0.2 percent greater than $89.65 mc^2$, the value which fits proton-proton scattering data.

The reason that the agreement between the proton-proton and proton-neutron interactions

is better for the meson well than for the Gauss error or square potentials is the very large depth of the meson well at small radii, as will now be discussed. Since the calculations show that the proton-neutron experimental data are fitted by a meson well which is the same to within experimental error as the meson well fitting the proton-proton data, it will be assumed that the two wells are identical. It will follow from this assumption that for a square well the proton-neutron attraction is greater than that between protons. By means of Eq. (3) one can obtain the depth of a square well of radius e^2/mc^2 from the depth of the meson potential. To the first order one has to adjust the square well depth so that

$$\int \mathfrak{F}_{\pi n}^2 E^{-1/2} \delta V_{\pi n} dr = 0,$$

where $\delta V_{\pi n}$ = (square well potential) - (meson potential) and $\mathfrak{F}_{\pi n}$ is the function for the meson well for the proton-neutron singlet state scattering problem. In the same way, starting from the same meson well, one can find a square well of the same width and of such a depth that it fits the proton-proton scattering data and there is no change of phase shift K_0 ; i.e., such values of $\delta V_{\pi \pi}$ are found that

$$\int \mathfrak{F}_{\pi \pi}^2 E^{-1/2} \delta V_{\pi \pi} dr = 0,$$

where $\mathfrak{F}_{\pi \pi}$ is the function for the meson well for the proton-proton scattering problem. Since

$$\delta K = \text{const.} \int \mathfrak{F}_{\pi n}^2 \delta V_{\pi n} dr = 0$$

and only $\mathfrak{F}_{\pi n}$ inside the well is important for the integral, one can make $\mathfrak{F}_{\pi n}$ equal to $\mathfrak{F}_{\pi \pi}$ at some radius by multiplying $\mathfrak{F}_{\pi n}$ by a constant and, to the first-order approximation,

$$\int \mathfrak{F}_{\pi n}^2 \delta V_{\pi n} dr = 0$$

will remain unchanged. Suppose that $\mathfrak{F}_{\pi n}$ is made equal to $\mathfrak{F}_{\pi \pi}$ at some very small radius; then at small radii they will be almost equal, but since $\mathfrak{F}_{\pi \pi}$ is less bent, because of the presence of the Coulomb potential, it will become increasingly

¹⁰ L. Simons, Phys. Rev. **55**, 792(L) (1939).

¹¹ G. Breit, L. E. Hoisington, S. S. Share and H. M. Thaxton, Phys. Rev. **55**, 1103(L) (1939).

* Reference 6, pp. 1043, 1057.

larger than $\mathfrak{F}_{\pi\nu}$ as the radius increases. Because of the small difference between $\mathfrak{F}_{\pi\pi}$ and $\mathfrak{F}_{\pi\nu}$ from $r=0$ to $r=0.5 e^2/mc^2$, and because of the small value of δV from $r=1$ to $r=3 e^2/mc^2$, the most important region for the comparison of the two integrals is from $r=0.5$ to $r=1 e^2/mc^2$. Since $\mathfrak{F}_{\pi\pi}$ is larger than $\mathfrak{F}_{\pi\nu}$, $|\delta V_{\pi\pi}|$ must be smaller than $|\delta V_{\pi\nu}|$ in this region in order that the integral be zero. To compensate for the very large depth from $r=0$ to $r=0.5 e^2/mv^2$, the meson well is comparatively shallow from $r=0.5$ to $r=1 e^2/mc^2$, so that in this interval δV is negative, and a smaller $|\delta V_{\pi\pi}|$ means a raising of the bottom of the square well, so that the square well fitting proton-proton scattering is not as deep as that fitting proton-neutron scattering. The argument would be the same in comparing the meson and Gauss error wells.

As a test, the required difference of square well depth was calculated very roughly in the above manner, and was found to be 0.3 (5) Mev, which was considered to be good agreement with the difference 0.1 (7) Mev found by direct fitting to the experimental data.

That locating the main part of the attractive potential at shorter radii should give better agreement between the proton-proton and proton-neutron interactions can also be seen from the equation

$$\frac{\rho \mathfrak{F}'}{\mathfrak{F}} = y \frac{X + (2 \ln 2y + f) \Phi_0^*}{\Psi_0 + y(2 \ln 2y + f) \Phi_0} \quad (4)$$

(Eq. (7.5) of BCP².) This formula gives the value of the logarithmic derivative of \mathfrak{F} at the edge of a well of width ay for a given phase shift K_0 . Here $a = 2\hbar^2/Me^2$. As the well becomes narrower, i.e., as y becomes smaller, X approaches 2; Φ_0^* , Φ_0 and Ψ_0 approach unity, and f remains unchanged, so that because of the $2 \ln 2y$ term in the numerator the logarithmic derivative becomes smaller and can be made equal to zero. This corresponds to an increase of the theoretically expected proton-neutron scattering cross section from 0 to ∞ . One would expect, therefore, that a suitably narrow range could be found that would make the well depth required for proton-proton

scattering at a fixed energy just equal to that required for proton-neutron scattering.

It may be significant that the meson potential well fits the proton-proton experiments and that for it the proton-proton and proton-neutron interactions are equal within the experimental error of scattering experiments. The value $a = 0.42 e^2/mc^2$, however, corresponds to a meson mass of $326 m$, and it is apparent from Fig. 2 that a lighter meson of mass $\sim 180 m$ will not give results fitting proton-proton scattering data. It may be that calculations using higher orders of the meson field theory will result in a smaller calculated mass, or perhaps the interaction is caused by a particle actually having the heavier mass. If the interaction is due to neutral mesons as is apparently indicated by Bethe's¹² calculations of the deuteron quadrupole moment, no direct information about the mass would be obtained from cosmic rays. It would nevertheless be strange if the mass of the neutral meson were almost twice as large as that of the charged meson.

The partial success of the meson potential in the above attempts to fit experiment is far from being a definite encouragement for the meson theory of nuclear forces. The promising features are the rather good fit to the experimental K_0 , E curve and the internal consistency of the "symmetric Hamiltonian" point of view indicated by the agreement of the proton-proton and proton-neutron interactions. The discouraging feature is the very poor agreement of the mass of the meson as obtained from proton-proton scattering and from cosmic-ray evidence. It is conceivable that improvements in the meson theory will affect the slope of the theoretical K_0 , E curve more than the order of magnitude of the expected quadrupole moment of the deuteron and it is also imaginable that the mass of the particle responsible for nuclear forces is greater than that of the particle seen in cosmic rays. More fundamental work on these questions is obviously needed and it is clear that quantitative applications of the meson theory to problems of nuclear structure are still very questionable.

¹² H. A. Bethe, Phys. Rev. **55**, 1261 (1939).