

in some cases at least the line width contribution due to linkage with neighboring atoms is very small.⁴⁰

The narrow $K\alpha_{1,2}$ lines for calcium oxide as compared with the widths for metallic calcium

⁴⁰ An analysis of the widths of the $K\alpha_{1,2}$ lines for Kr(36) measured by Wilhelmy is instructive. The observed widths are 0.37 and 0.33 X.U. for α_1 and α_2 , respectively. Corrected for the crystals by Eq. (1) these widths become 0.31 and 0.27 X.U. Less the radiation damping width, 0.13 X.U. from Table I of Prins, reference 31, the respective widths are 0.18 and 0.14 X.U. Wentzel, *Zeits. f. Physik* **43**, 524 (1927), finds that the Auger width is about equal to the radiative width for Kr(36) so that there are left the small residual widths of 0.05 and 0.01 X.U. (about equal to the observational errors as estimated by Wilhelmy) to be accounted for by the width factors four and five as listed above. This is evidence that factors four and five (and also factor three in the cases of adjacent solid elements when the Kr $K\alpha_{1,2}$ widths are compared with the line widths for these adjacent elements) are of small importance in these lines for $Z=36$. The Kr $K\alpha_{1,2}$ lines are symmetrical and agree with the classical dispersion shape within the errors of observation.

leads one to question the significance of the smoothness of the curves drawn in Fig. 6. The widths for scandium oxide may also be low compared with the widths one might measure for free scandium, but, on the other hand, the oxide of manganese gives wider lines than does pure manganese.⁴¹

VI. ACKNOWLEDGMENTS

The author is pleased to express his indebtedness to Professor F. K. Richtmyer, Drs. E. G. Ramberg and C. H. Shaw for stimulating discussions, and especially to the University of Chicago for the loan of the double spectrometer with which the data were recorded.

⁴¹ L. G. Parratt, *Phys. Rev.* **45**, 364 (1934); J. A. Bearden and C. H. Shaw, reference 29, footnote 16; and H. H. Roseberry and J. A. Bearden, *Phys. Rev.* **49**, 884A (1936).

JULY 1, 1936

PHYSICAL REVIEW

VOLUME 50

A Precision World Survey of Sea-Level Cosmic-Ray Intensities¹

ROBERT A. MILLIKAN AND H. VICTOR NEHER, *Norman Bridge Laboratory of Physics, California Institute of Technology*
(Received April 23, 1936)

With sensitive, vibration-free, self-recording electroscopes sent to many parts of the globe on twelve different voyages a precision survey has now been completed of the variation of cosmic-ray intensities both with latitude and longitude, so that the earth as a whole can now be covered with sea-level, equal intensity, cosmic-ray lines. In going along the longitude line 75° W., which runs from the far north through Washington, D. C., and along the west coast of South America, there is no appreciable change until the magnetic latitude of about 41° is reached. The equatorial dip then begins to set in and shows a maximum decline of 8 percent off Peru and returns again to its normal value off Cape Horn. In going along longitude line 80° E. through southern India the maximum dip is 12 percent. In going south from Alaska in longitude 165° W. to New Zealand the maximum dip is 10 percent. In going south from Liverpool through the Atlantic Ocean—longitude 30° W.—and around Cape Horn the maximum dip

is 8.5 percent. In the region most accurately studied—the west coast of the United States—the intensity remains exceedingly constant until the latitude of Pasadena—41° magnetic—is reached, and then drops remarkably suddenly. In the Atlantic Ocean the drop sets in at about the same magnetic latitude with equal suddenness. It appears also to take place quite suddenly at about magnetic latitude 41° in the southern hemisphere. Nevertheless, the existence of a longitude effect shows that in strictness there is no such thing as magnetic latitude. In other words, the earth's magnetic field, even at the remote distances of thousands of miles at which these deflections occur, is strikingly dissymmetrical with respect to any line passing through the earth's center. This method of study opens up the possibility of determining these dissymmetries at large distances from the earth. The observed magnetic effects are to be expected quite independently of whether cosmic rays are in their origin photonic or corpuscular.

THE first element in the high altitude survey of cosmic-ray intensities as a function of latitude organized in the fall of 1931² was the development of what the first of the authors has

designated as “the Neher vibration free, cosmic-ray electrocope.” It has been with its aid that this sea-level survey has been made.

§1. THE ELECTROSCOPE

This instrument was a modification of the cosmic-ray electrocope which Millikan and Cameron had developed in 1927 and had used in

¹ A condensed report of this work was published in *Science* **82**, 574 (1935).

² I. S. Bowen, R. A. Millikan and H. V. Neher, *Phys. Rev.* **44**, 246 (1933). See also International Conference on Nuclear Physics (Cambridge Univ. Press, 1934), p. 210.

all their cosmic-ray measurements made from 1927 to 1930. Like its predecessor it consisted of a spherical steel bulb of 3 mm wall thickness and 15 cm diameter filled with gas at pressures up to 30 atmospheres and holding at its center a gilded quartz fiber electroscop system, readable, by means of a short focus telescope, through a window in the wall. Such an electroscop with no outside connections of any kind, if properly dried with phosphorus pentoxide, eliminates the serious uncertainties and difficulties inherent in electroscopes having outside connections, especially when these are used in moist surroundings.

In the earlier years air was used as the filling gas but argon was also used beginning in the summer of 1931 and since 1932 it has been exclusively used. We have, however, one air electroscop that was filled at 30 atmospheres in September, 1928, the reading of which, within its 10 cm lead shield in the basement of one of our homes, now used as a standardizing laboratory, has not varied appreciably during these eight years. In a given cosmic radiation field its current is 13.8 times that found when its pressure is reduced to one atmosphere. Through comparison

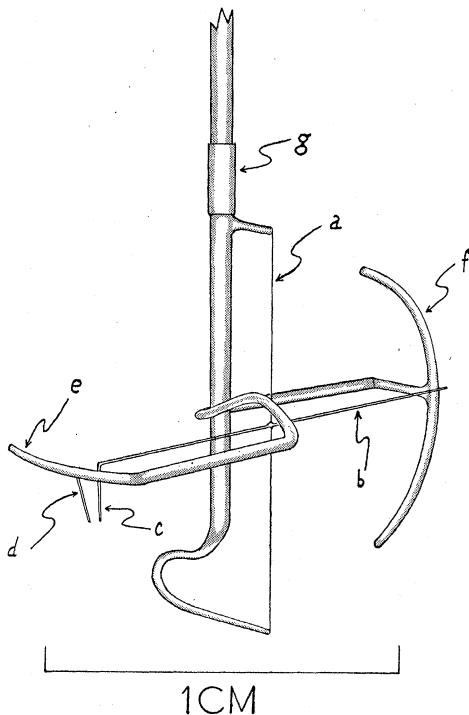

FIG. 1. The quartz electroscop system used in our tilt and vibration-free cosmic-ray instrument.

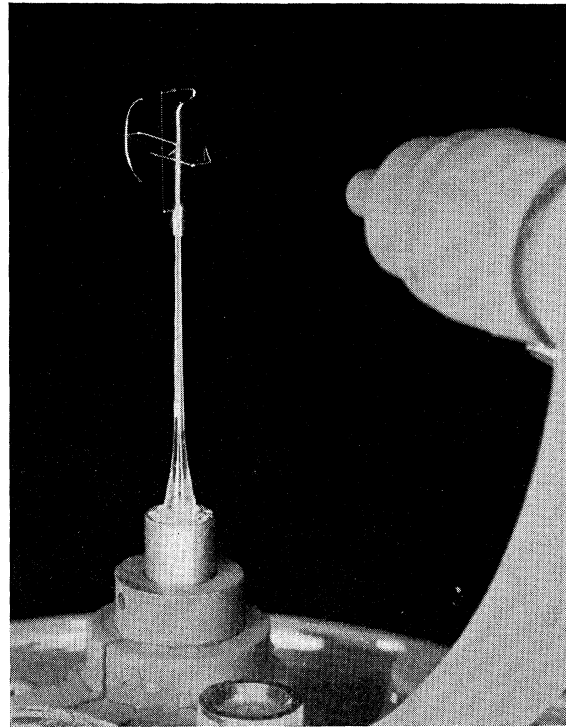

FIG. 2. Illustrating the quartz system when ready for installing into the ionization chamber. The lens mounting is supported by a rigid arm which is securely fastened to the same piece that holds the electroscop system.

with it and with the aid of this multiplication factor, all our argon-electroscop readings are reduced to ionization in air at one atmosphere. Such reduction is made in most of the accompanying charts. The exactness of this reduction is not, however, important for the purposes of this paper, since the essential comparison is here merely between the reading of the given electroscop at Los Angeles, from which port it always starts out and to which it always returns, and its reading in the other localities to which it is taken.

The design of the suspension of this electroscop is shown in Fig. 1. The system is of the torsion type and is made entirely of fused quartz. The 5μ fiber *a* is stretched until its length is increased about one percent. The 30μ movable cross arm *b* is bent at right angles at one end where it is drawn down to a thickness of about 10μ . The image of *c* cast on the recording film by a lens giving a magnification of 10 has then a convenient width on the film. The short bit of fiber *d* serves as a fiducial mark and it, together

with the part *e* (which is bent into the arc of a circle with the torsion fiber as a center) and the stop *f*, combines to give a linear scale over practically the whole range of discharge. *g* is a piece of platinum cemented to the quartz and is the point at which a new charge is automatically placed on the system at regular time intervals. With a very small oxygen flame all joints are fused together so that the whole system becomes essentially one piece of quartz. A twist of about 30° is placed permanently in the torsion fiber so that no motion of the movable arm takes place until about 250 volts are reached and then the full deflection of 2 mm results for the next 75 volts. The whole system from *g* down is covered with a conducting layer of gold by evaporation. The movable part *b* is balanced by cutting off one end until a tilt of 90° causes less than 0.005 mm actual motion of *c*. Besides being free from tilt the system because of the large ratio of strength to weight is quite insensitive to vibration.

The electrostatic capacity is approximately 0.43 cm. In a 100 div. scale placed in the eyepiece the voltage sensitivity is about 0.7 volt/div. This results in a charge sensitivity of approximately 10^6 ions/div.

Fig. 2 is a photograph of the suspension and its supports. The complete instrument is shown in Fig. 3 while Fig. 4 illustrates the recording mechanism as well as that available for visual observation. The film runs just behind a narrow horizontal slit in a disk at the right end of the brass tube connecting the electroscop chamber on the left with the recording chamber on the

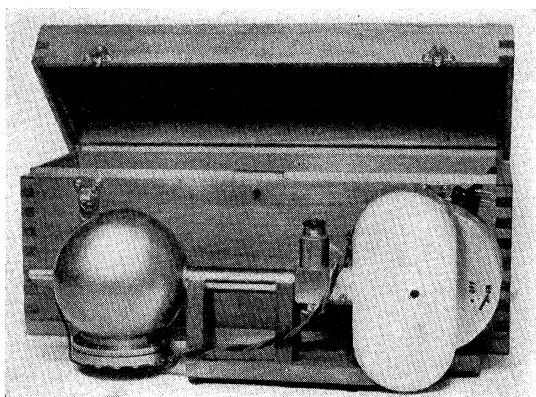

FIG. 3. The instrument used in this survey is usually shielded with lead and is placed in the box when used in most airplane flights.

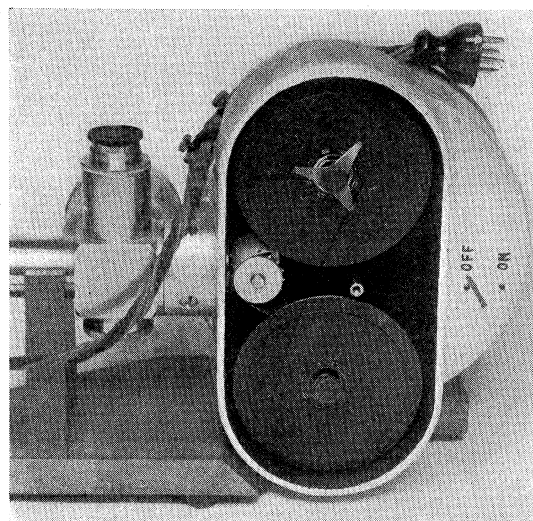

FIG. 4. The camera will take a one hundred foot reel of 35-mm motion picture film which is driven at a constant rate past the slit by a power clock. Changeable gears allow various rates of film speeds to be used, depending on the expected ionization.

right. The image of *c* (Fig. 1) travels across this slit as the electroscop discharges so that where this image intersects the slit there is produced an unexposed point on the film which travels diagonally across the film as the electroscop discharges. In this survey the electroscop was automatically charged up once every hour. Fig. 5 shows a sample strip of the developed film. The rate of discharge during an hour's run is given by the slope of each diagonal line of this film. The mean of 24 of these slopes gives the mean intensity for the day in question. Fig. 6 shows the electroscop both completely and partly housed in its lead shield 11 cm thick,³ the

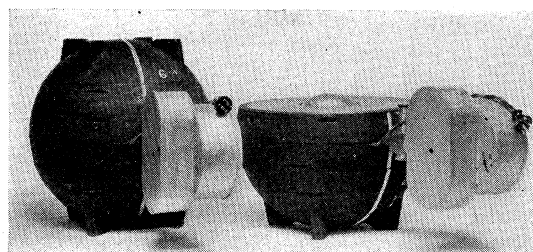

FIG. 6. An 11 cm lead shield protected by a one-half inch shell of cast iron has been used for most of the survey to insure freedom from local variations in radiation.

³ The lead is actually 10 cm thick and we have often called it a 10-cm shield. Counting the iron rim, which prevents the distortion of the lead, it is the equivalent of a 11-cm Pb shield and is herein so designated.

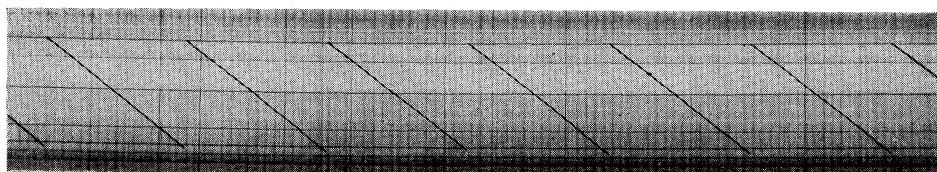

FIG. 5. Showing the type of record obtained at sea level in this world survey. Two of the horizontal lines give barometric and temperature records.

left hand assembly showing how it looks when placed aboard a ship. The accuracy and stability of this instrument as revealed by the high altitude airplane flights (up to 29,000 ft.) which we made with it in the summer of 1932 and the spring of 1933 in northern Canada, northern and southern United States, Panama and Peru, was such that in the winter of 1933 we introduced slow motion gears suitable to the slow rate of discharge found at the earth's surface and began the precision sea-level survey. This was completed in the fall of 1935 and is reported in full herewith.⁴ The total weight is 625 lbs.

§2. THE EQUATORIAL DIP IN THE LONGITUDE OF THE WEST COAST OF SOUTH AMERICA

The aim of the survey was to attain as high an order of accuracy in comparing sea-level ionizations all over the world as had been attained in 1930 in comparing the mean cosmic-ray intensity at Pasadena with that at Churchill, Manitoba. In establishing the equality of the cosmic radiation existing between these two localities, the mean of not less than a week of continuous readings day and night with the same electroscope in each locality was taken and at the same temperature. Such precautions made it possible to assert with great certainty that the mean cosmic-ray intensity at Pasadena and at Churchill did not differ by as much as one percent.

Our first concern was to fix accurately the amount of the equatorial dip, or reduction of cosmic-ray intensity shown in the readings of an electroscope sent from Los Angeles to the western coast of South America. To get this with high precision it was necessary, as in 1930, to let the electroscope remain in the same place for a week

⁴ A brief report has already appeared in the publications of the Carnegie Institution of Washington, No. 34, pp. 343-345. It was read in the Proceedings of the National Academy of Sciences for November, 1935.

or so at a time so as to render the mean as independent as possible of the erratic daily fluctuations which because of "Hoffmann bursts" rise sometimes to a two-percent value though ordinarily they are much less than this. The instrument was placed on board Capt. Allan Hancock's yacht, the *Valero III*, and in a voyage of three months' duration the results shown in Fig. 7 were obtained. The numbers attached to the most significant points give the number of days during which the ship remained stationary at these points. These fix with much precision the equatorial reduction in cosmic-ray intensity measured by an electroscope inside 11 cm of lead between the latitude of Los Angeles harbor at San Pedro (Geographical 33.7° N., magnetic 41° N.) and Mollendo (Geographical 17° S., magnetic 6° S.) as 7.1 percent. The crosses represent daily readings obtained on another voyage with the same electroscope from Panama to Mollendo (Peru) and return to Panama. These results have been checked by two other voyages with a shielded electroscope, one between Los Angeles and New York, via the Panama Canal, and one between Mollendo and New York, via the Panama Canal, with mean results which are in agreement with the findings of the *Valero III* to within about three-tenths of a percent.⁵ These four separate voyages seem to us to fix the mean equatorial dip in this longitude with much certainty.

We then sent an unshielded electroscope between Mollendo and Los Angeles and found here too a seven percent lower reading at Mollendo than at San Pedro,⁵ thus establishing the fact that *the equatorial dip is essentially the same as measured in percentages whether the readings are taken inside a 11 cm lead screen or outside.*

⁵ These curves have already been published, Phys. Rev. 47, 207 (1935).

§3. THE SUDDENNESS WITH WHICH THE EQUATORIAL DIP SETS IN

The next point of much importance was to determine very accurately the change in sea-level intensity between, say, Los Angeles and Victoria, B.C. (Geological latitude 48.3°, magnetic 54.3° N). For this purpose we took two different electroscopes on a voyage from Seattle, via Victoria, to Los Angeles. In this case both of us accompanied the electroscopes, one of which was placed outside its lead shield and read visually every four hours, while the other was inside its shield and adjusted to move across the field once every hour. The instruments were in a state room next the bridge, the temperature of which was kept constant so that only barometric changes had to be allowed for and these were small. These

results reveal so well the kind of consistency obtained in the readings as well as the extraordinary uniformity of the sea-level ionization over this range of latitudes that the summarized readings, taken continuously four hours apart by electroscope No. 1 over a period of five days, are given in Table I, as well as the corresponding readings of electroscope No. 2.

Both of these instruments had zero readings of the order of 1 ion per cc/sec., as determined by observation in a tunnel 250 ft. beneath the earth's surface, so that the ionization is practically all due to cosmic rays. It will be seen that the fluctuation from the 12 hour means never in these five days exceeds one percent. These readings show, then, with great conclusiveness that *within the limits of accuracy attained with these sensitive instruments there is no change in*

TABLE I. Five-day study of sea-level variations of cosmic-ray intensities between Victoria, B. C. and Los Angeles.

ELECTROSCOPE NO. 1—UNSHIELDED (ions cc/sec.)				ELECTROSCOPE NO. 2—SHIELDED (11 cm Pb)			
	Lat.	4-hour Means	12-hour Means	Lat.	Long.	Mag. Lat.	12-hour Means
In Seattle Harbor	47.5	39.91 39.25	39.58*	47.5	122 W.	53.5 N.	24.60 Seattle
				48.3	123 W.	54.3 N.	24.71
In and near Victoria	48.4	39.41 39.64 39.29	39.45	46.5	124 W.	52.5 N.	24.65
				44.0	124 W.	50.0 N.	24.78
At Sea	48.2	39.25	39.53	41.0	124 W.	47.0 N.	24.49
" "	47.2	39.52		37.5	122 W.	43.5 N.	24.79 San Francisco
" "	46.25	39.83		36.0	122 W.	42.0 N.	24.57
" "	45.3	39.31	39.67	34.0	119 W.	40.6 N.	24.45†
" "	44.3	40.12		Mean 24.63			
" "	43.5	39.58					
" "	42.5	39.44	39.69				
" "	41.6	39.94					
" "	40.8	39.69					
" "	40.0	39.28	39.33				
" "	39.0	39.12					
" "	38.0	39.62					
In San Francisco Harbor		39.72	39.82				
" " " "		40.38					
" " " "		39.36					
" " " "		40.04	39.61				
" " " "		39.54					
" " " "		39.25					
" " " "		39.65	39.65				
At Sea	37.3	39.55					
" "	36.4	39.76					
" "	35.5	39.71	39.65				
" "	34.7	39.76					
" "	34.2	39.43					
		Mean 39.60					

* 8-hour average.

† 9-hour average.

intensity whatever between Victoria, mag. Lat. 53, and Los Angeles, mag. Lat. 41. Taken in connection with Fig. 6 these figures show however that the equatorial dip sets in with quite surprising sharpness very close to Los Angeles.⁶ Indeed, from the 10-day means taken in Los Angeles harbor at San Pedro and the means of more extended readings in Pasadena, which agree accurately with the mean readings both at Churchill, Manitoba, and at sea just north of Los Angeles, there seems to be a measurable fraction of a percent (about 0.7 percent) of drop in sea-level intensity between these two points Pasadena and San Pedro only 33 miles apart in a north-south line. Also, the suddenness of the change just south of Los Angeles harbor shows strikingly in Fig. 7. Further, the readings in this

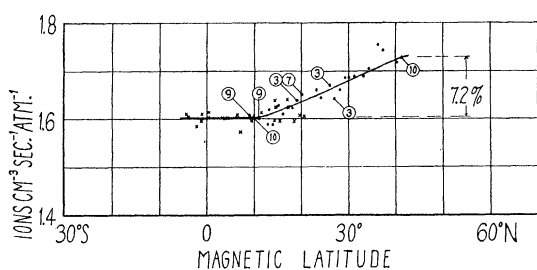

FIG. 7. Measurements taken aboard Captain Hancock's yacht, *Valero III*, have established accurately the amount of drop in ionization between Los Angeles harbor and the west coast of South America.

harbor are about this amount lower than the mean of the readings taken above magnetic latitude 41° in the neighborhood of New York in the two trips between Panama and New York. In consequence we are taking the equatorial dip in going from the polar and temperate latitude south through the equatorial belt along the longitude of the western coast of South America as eight percent and we feel confident that this cannot be as much as a percent in error.⁷

⁶ It was because of the suddenness and the extent of the drop in the immediate neighborhood of Los Angeles harbor that Millikan and Cameron failed to notice the equatorial sea-level dip at all in the first voyage made in 1926 to check their theory that it ought to exist. They were unable to get their instruments installed and working on deck until they had been out about a day and a half. The constancy observed south of this point was quite consistent with the sensitivity of the electroscopes then in use.

⁷ These curves have already been published, *Phys. Rev.* **47**, 207 (1935).

§4. THE EQUATORIAL DIP IN THE LONGITUDE OF SINGAPORE

Our next objective was to determine the variations in sea-level intensity shown on the Dollar Line "round the world cruises," the route of which is Los Angeles, San Francisco, Honolulu, Kobe, Shanghai, Singapore, Red Sea, Genoa, Gibraltar, New York. The results of two such cruises on the *President Garfield*, *Captain Cullen*, and the *President Hayes*, *Captain Pierson*, are shown in graph form in Fig. 8. The *President*

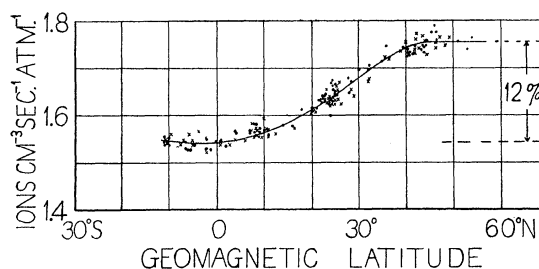

FIG. 8. These two trips around the world were taken by the same instrument and agree in showing the same relative as well as the same absolute values at times separated by one year.

Garfield cruise was made from August 1 to November 19, 1933. The *President Hayes* cruise was made from August 26 to December 16, 1934. Both the consistency of the readings on each cruise and the agreement between the observations in different years are noteworthy. It was the cruise of the *President Garfield* compared with the cruises from Los Angeles to the west coast of South America that brought to us our knowledge in January, 1934, of the longitude effect which was reported by us to the National Academy of Sciences and the Physical Society in April, 1934. This longitude effect was discovered independently and simultaneously by Clay and briefly mentioned in *Physica* in March, 1934. In our case the evidence inhered in the unambiguous finding that the equatorial dip in going across the magnetic equator in the longitude of Singapore was 12 percent instead of the eight percent value found on the South American side of the globe.

§5. EQUATORIAL DIP IN THE LONGITUDE OF SAMOA

In none of these voyages had we explored the rise in sea-level ionization in going from the

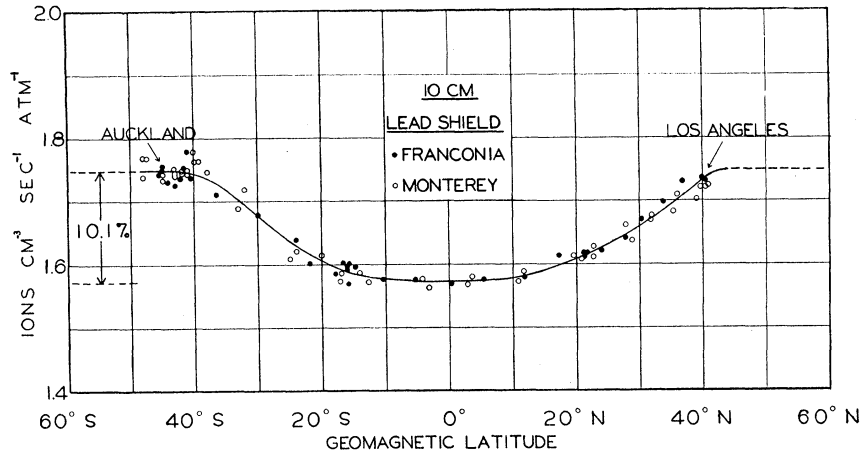

FIG. 9. The two trips here, made nine months apart, taken together with Fig. 8, show the consistency to be expected on going over the same route at different times.

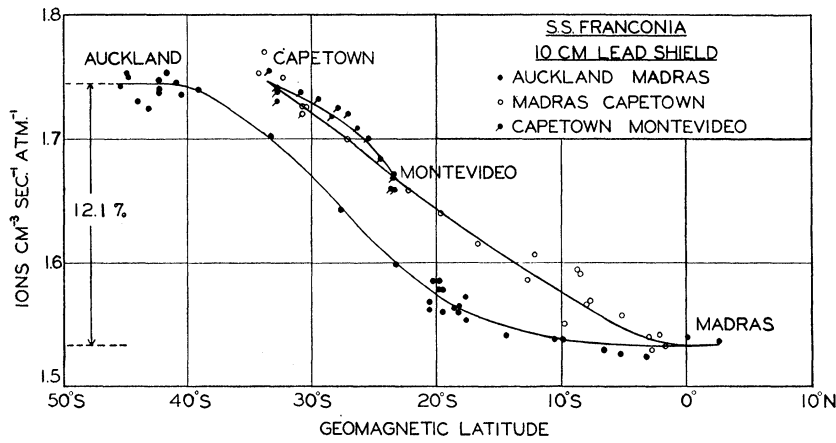

FIG. 10. On this section of the world cruise of the *S.S. Franconia* the longitude effect is very strikingly brought out.

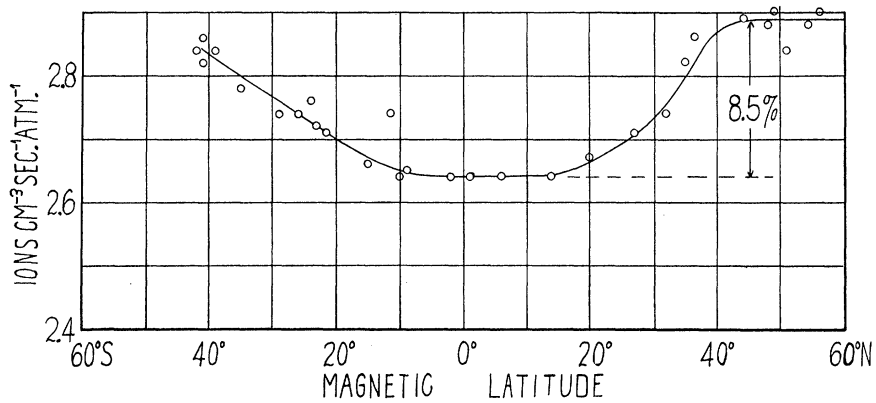

FIG. 11. The above data were obtained with an unshielded instrument from the trip of the *S.S. Reina del Pacifico* from Liverpool through the Straits of Magellan and up the west coast of South America. Both the shielded and unshielded instruments agree in showing that the drop at sea level sets in at about 41° geomagnetic latitude north.

equatorial zone to the southern temperate zone. Accordingly we sent two voyages across the equator and far into the southern hemisphere as follows: In June, 1934, we placed one shielded and one unshielded Neher electroscopes in the room of First Officer Graham of the *S.S. Monterey* of the Matson Line and got an excellent record both going and coming between Los Angeles and Melbourne, Lat. 38 S., Mag. Lat. 48 S., in the case of the shielded electroscopes, and a good record in the unshielded one on the way down. The percentage of dip was again quite the same with the shielded and with the unshielded electroscopes and the dip itself, in crossing the equatorial belt in the longitude of the Samoan Islands, was ten percent, that is, a value intermediate between its values in South America and Asia.⁸ To check these values and also get a more complete covering of the southern hemisphere, in January, 1935, we placed a shielded electroscopes in a state room close to the bridge, in charge of Officer N. Kingscote of the Cunard liner *Franconia* bound for Honolulu, Samoa, Auckland, Sydney, Singapore, Madras, Colombo, Zanzibar, Capetown, Montevideo, New York. The notable consistency of the results obtained both in different years and different seasons between Los Angeles and Auckland is shown in Fig. 9, scarcely any day's run being off the line more than one percent.

⁸ These results are shown in the graphs found in Phys. Rev. 47, 207 (1935).

Fig. 10 shows the results obtained in going from Auckland to Madras, then to Capetown and from there to Montevideo.

It is quite clear that in going from Madras to Capetown the region of the earth which can produce a large equatorial dip is rapidly being left behind and the much smaller dip, like that first found on the west coast of South America, is being rapidly approached.

§6. EQUATORIAL DIP IN THE MID-ATLANTIC

This value of the equatorial dip, in going across the equatorial belt in the mid-Atlantic, was obtained by sending another Neher electroscopes on the *S.S. Reina del Pacifico*, sailing from Mollendo up through the Panama Canal to Liverpool, then after a stay of a few weeks in that port south through the mid-Atlantic and around the end of South America. The results, without shield, from Liverpool to "Magallanes" are shown in Fig. 11 and from Magallanes to Valparaiso and then from Lima to Los Angeles, on another boat, in Fig. 12. The results obtained with this unshielded electroscopes are much more erratic than any of the others which we have taken, presumably because the usual precautions were not taken to keep passengers away from an *unshielded* electroscopes. The single point that is badly off the line in Fig. 11 is presumably due to this same cause or else to a large burst occurring on that day.

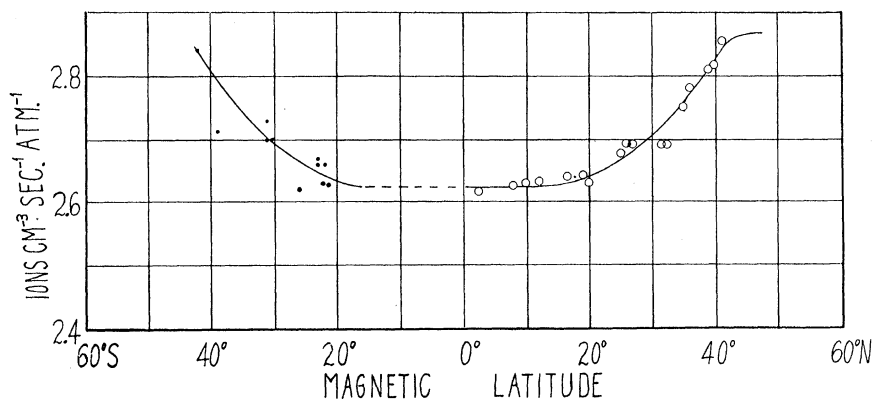

FIG. 12. The portion of the trip of the *Reina del Pacifico* up the west coast of South America to Valparaiso is compared with an unshielded instrument from Lima to Los Angeles harbor. Taken with Fig. 11 a longitude effect appears to be evident between the east and west sides of lower South America.

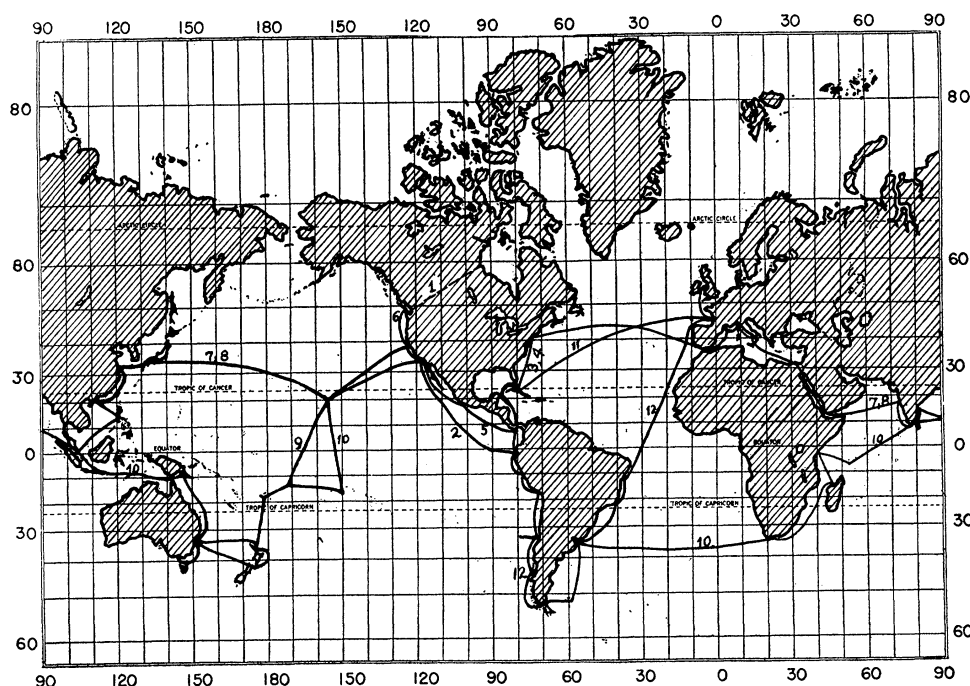

FIG. 13. This survey is the result of twelve different trips which have included most of the chief commercial routes on the oceans. No. 1 represents the Churchill trip in 1930.

§7. GENERAL SIGNIFICANCE OF THE SUDDENNESS OF THE SET-IN OF THE EQUATORIAL DIP

It is the extreme constancy of the sea-level readings down to the latitude of Pasadena, as shown in Table I, and the notable suddenness with which the equatorial drop in intensity begins to set in just south of Pasadena, as shown in Figs. 7, 8, and 9, that enables the resistance of the atmosphere to incoming electrons to be fixed, through the Epstein-Lemaitre-Vallarta analysis, at 6 billion electron-volts with an uncertainty of perhaps 20 percent.

This single sudden break in sea-level intensity also constitutes evidence against the existence of two kinds of incoming charged particles, such as protons and electrons, of notably different absorbabilities; since this would require two such breaks, one considerably farther north than magnetic latitude 41° , while no such second break actually appears.

Further, the constancy of the sea-level ionization down to magnetic latitude 41° shows that incoming particles of 6 billion electron-volts of energy have a sharply limited range. This constancy means that

the effects of practically all incoming particles of higher energy than 6 billion electron-volts reach down to sea level. On the other hand, while incoming particles of lower energy definitely produce ionization effects in the *upper* atmosphere, as shown clearly by the difference between our altitude-ionization curve* taken at Pasadena (March Field), magnetic latitude 41° , and at Spokane, magnetic latitude 54° , yet they have no influence on sea-level ionization. Again, the identity of these altitude-ionization curves up to 22,000 feet between Spokane and The Pas (magnetic latitude 63°N), shows that the effects of 2.4 billion electron-volts (the energy required here to get through the blocking effect of the earth's magnetic field) cannot reach down to 22,000 feet, though they are abundantly found above this altitude.** *These definite indications of range phenomena in the incoming electrons are of much significance for the general understanding of the nature of the particle component of the incoming cosmic rays.*

* Bowen, Millikan and Neher, *International Conference on Physics*, Vol. I, "Nuclear Physics" (London, 1934), p. 210. Also *Phys. Rev.* **46**, 642 (1934).

** See Figs. 4 and 6 of above references.

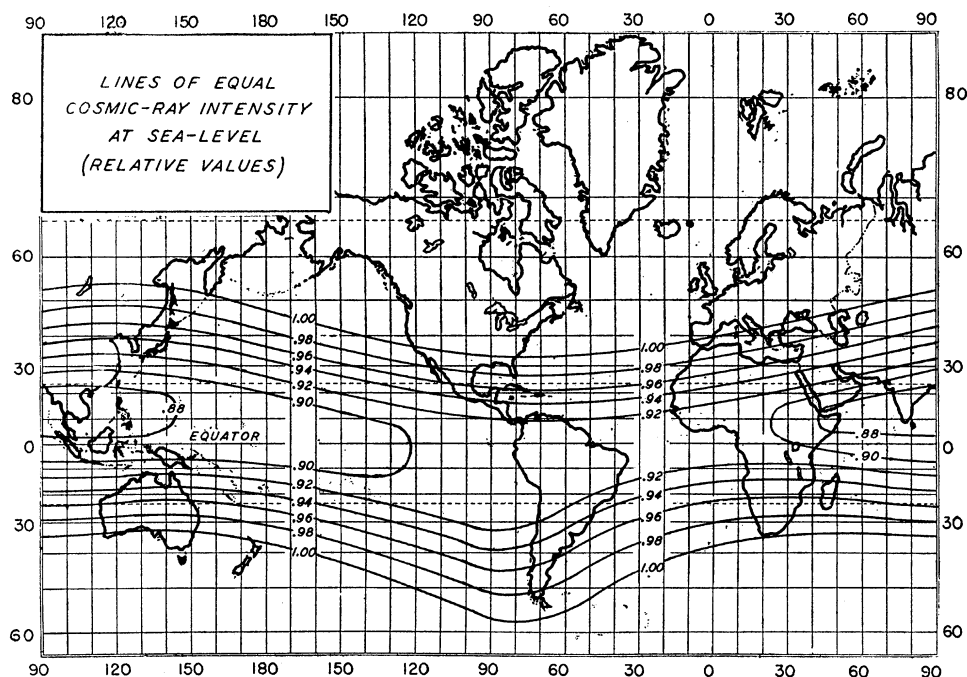

FIG. 14. The results of the survey at sea level are here represented in a consistent scheme of lines of equal cosmic-ray intensity. These lines in general are parallel to the geomagnetic equator, the notable exceptions being in the region of lower South America and along the magnetic equator where the longitude effect appears. From the upper line north, and from the lower line south, the intensity of cosmic radiation at sea level remains constant.

§8. SUMMARY

The whole of our work in this survey is condensed into the maps shown in Figs. 13 and 14. The former shows all the voyages, the latter shows how the lines of equal cosmic-ray, sea-level intensity are distributed over the earth's surface. Our films are all available at the Norman Bridge Laboratory of Physics at Pasadena so that others who may desire to make studies of geographical variations in sea-level, cosmic-ray intensities can do so exceedingly easily by simply remeasuring these sets of films. We have tried to keep the measurements free from the personal

equation by having our films measured by two different observers whose points on the foregoing charts are actually completely indistinguishable.

We wish to make grateful acknowledgment to the Carnegie Corporation of New York and the Carnegie Institution of Washington which have supplied the funds with which this long continued survey has been made. Also, to the management and officers of the above mentioned vessels, who have allowed our installations to go into their ships and have kept our clocks wound up and running throughout the respective voyages, we herewith extend most hearty thanks.

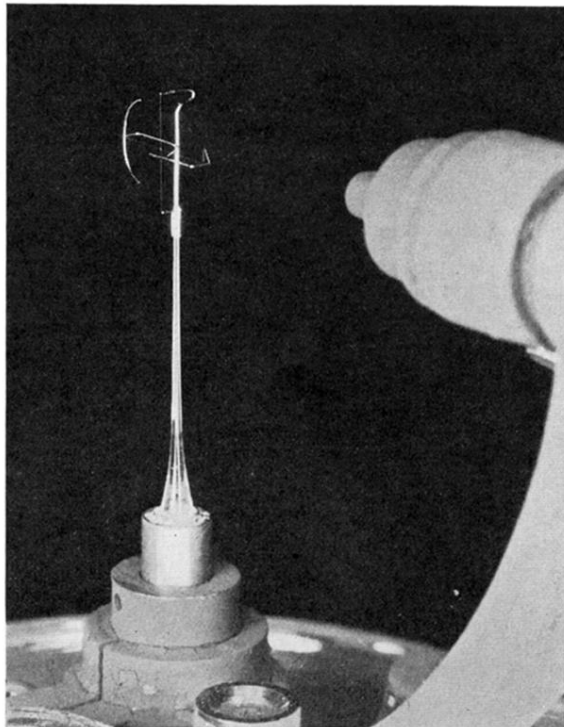

FIG. 2. Illustrating the quartz system when ready for installing into the ionization chamber. The lens mounting is supported by a rigid arm which is securely fastened to the same piece that holds the electroscope system.

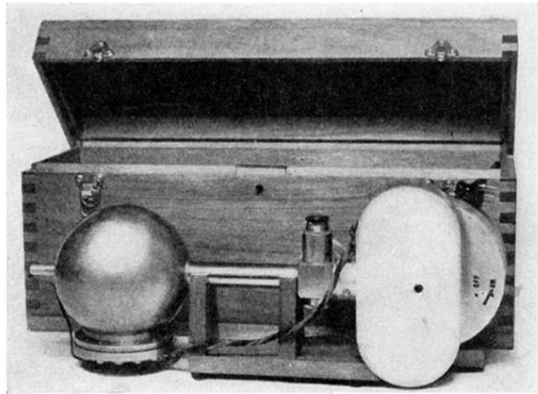

FIG. 3. The instrument used in this survey is usually shielded with lead and is placed in the box when used in most airplane flights.

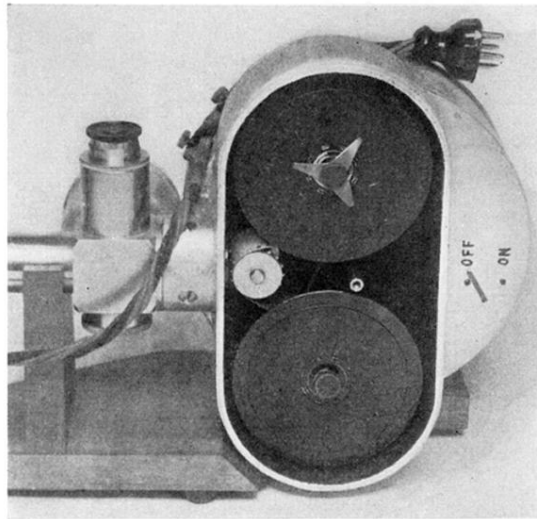

FIG. 4. The camera will take a one hundred foot reel of 35-mm motion picture film which is driven at a constant rate past the slit by a power clock. Changeable gears allow various rates of film speeds to be used, depending on the expected ionization.

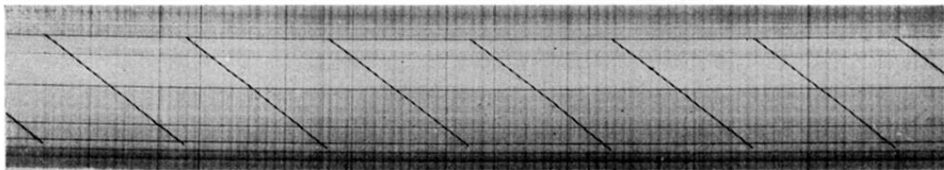

FIG. 5. Showing the type of record obtained at sea level in this world survey. Two of the horizontal lines give barometric and temperature records.

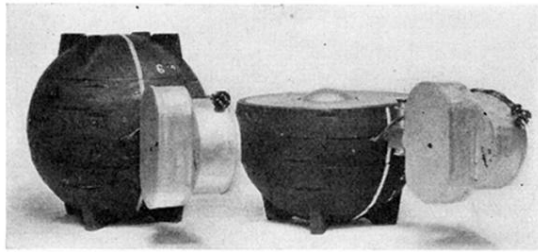

FIG. 6. An 11 cm lead shield protected by a one-half inch shell of cast iron has been used for most of the survey to insure freedom from local variations in radiation.