

The Value of the Townsend Coefficient for Ionization by Collision at Large Plate Distances and Near Atmospheric Pressure

By FREDERICK H. SANDERS
University of California

(Received June 13, 1932)

The Townsend coefficient of ionization by collision was measured at a pressure of 380 mm in air at plate distances ranging from one to five cm for values of X/p (the ratio of the field strength to the pressure in mm) from 20 to 36.5. It was found that the simple Townsend relation, $i = i_0 e^{\alpha d}$, is valid at the above pressure and over the above range of plate distances. The ratio α/p of the Townsend coefficient to the pressure in mm was determined as a function of X/p and the least-square reduction shows the function giving closest agreement with the observed data to be $\alpha/p = (2.67 \pm 0.26) \times 10^{-8} e^{(0.350 \pm 0.002)X/p}$. From these results it is evident that ionization by collision exists at much lower values of X/p than those given by Paavola. The rise in the saturation photoelectric current at the lowest X/p was compared with the recent work of Bradbury on the nature of the saturation photoelectric current and compares in order of magnitude with values found by extrapolation of the latter's equations. This indicates that below $X/p = 20$ the lack of saturation produces a fictitious value of α which renders measurements of α below $X/p = 20$ of doubtful value. No abnormal increase in the current with plate distance was found even within two percent of sparking. This indicates that if ionization by positive ions does exist it must occur at fields closer to sparking than two percent.

INTRODUCTION

IN 1900 J. S. Townsend¹ investigated the increase of the photoelectric saturation current from an electrode as a function of the distance between plane parallel electrodes for high values of the electric field or, better, for high values of X/p , the ratio of the electric field strength to the pressure. It was found that the current increased with the plate distance d at constant field strength according to the equations:

$$i = i_0 e^{\alpha d} \quad (1)$$

where i is the current at a distance d , i_0 the saturation photoelectric current at lower field strengths, and α a constant depending on X/p and the nature of the gas. A theoretical derivation of the experimental relation (1) was achieved by assuming that for a given X/p , α was the number of new ion pairs produced per centimeter of path in the gas by electron impacts. Townsend² evaluated α for various values of X/p and found α/p to be a function of X/p of a form closely analogous to that given by the equation:

$$\alpha/p = A e^{-B p/X} \quad (2)$$

where A and B are constants. This law he deduced theoretically, assuming the negative ions to make inelastic impacts with the gas molecules. Townsend²

¹ J. S. Townsend, Nature **62**, 340 (1900).

² J. S. Townsend, Phil. Mag. **2**, 598 (1903).

further found that the currents for very high values of X/p could not be expressed by Eq. (1) but that a more rapid increase in current took place. This he explained by assuming that in these high fields the positive ions also produced ions by collisions with the gas molecules. The equation deduced on the assumption that each positive ion in the assumed uniform field X/p produced β new pairs of ions per centimeter of path was:

$$i = i_0 \frac{(\alpha - \beta)e^{(\alpha - \beta)d}}{\alpha - \beta e^{(\alpha - \beta)d}} \quad (3)$$

where β/p was evaluated from the experiments and found to be a function of X/p . It is seen that i approaches infinity when $\alpha - \beta e^{(\alpha - \beta)d}$ approaches zero. This is the condition for spark breakdown proposed by Townsend.

All of Townsend's investigations were confined to *low pressures, small plate distances and high values of X/p* for the more common gases, due to the limited experimental facilities available at the time. The investigations of Franck³ and countless others on the ionization and radiation potentials as well as Townsend's own work on the elasticity of electron impact made his theoretical deduction of Eq. (2) untenable as Compton⁴ and others have pointed out, although it appeared to fit fairly well as an empirical equation. It was later pointed out by Holst and Oosterhuis,⁵ by Rogowski, and by Loeb⁶ that while the values of β/p could be expected to play a rôle in spark discharge at low pressures and high values of X/p (in the region of the minimum sparking potential) it was impossible to expect β/p to have finite values of a magnitude leading to the Townsend sparking mechanism at values of X/p of 39 which is the value of X/p for spark breakdown in air at atmospheric pressure. This led Loeb⁶ and Rogowski⁷ independently and contemporaneously to suggest that at higher pressures where the positive ions could not ionize by impact in the uniform fields assumed to exist between the electrodes before breakdown, the increase in the number of ions due to the ionization by electrons in the dark current preceding breakdown might produce distorted fields, due to space charges, of sufficient magnitude to give β/p finite values and to cause the Townsend mechanism to occur.

Acting on this suggestion several attempts were made to develop such theories mathematically, stimulated further by recent discoveries connected with the short time interval involved in spark breakdown. All these theories required a knowledge of the Townsend coefficient α in gases like air for values of X/p corresponding to that required for a spark in air at atmospheric pressure and lower. These were not available as Townsend's measurements in air extended only to $X/p = 40$ and were rather meager in this region, most of his measurements extending upwards from $X/p = 100$.

³ Franck and Hertz, Verh. d. deut. phys. Ges. **15**, 373, 613 (1913). J. Franck, Zeits. f. Physik. **25**, 312 (1924).

⁴ K. T. Compton, Phys. Rev. **7**, 489, 501, 509 (1916). Compton and Benade, Phys. Rev. **11**, 234 (1918).

⁵ Holst and Oosterhuis, Phil. Mag. **46**, 1117 (1923).

⁶ L. B. Loeb, Jour. Frank. Inst. **205**, 305 (1928).

⁷ W. Rogowski, Archiv f. Elek. **16**, 761 (1926).

In order to supply the missing data it was thought worth while to study Townsend's coefficient α for electron ionization at pressures of the order of magnitude of an atmosphere and plate distances of the order of centimeters to correspond more nearly with the actual conditions involved in the study of spark discharge. The realization of the very elaborate equipment required for this investigation was in part made possible by a grant in aid from the National Research Council and the task was begun in the fall of 1929. When the work was well under way the results of M. Paavola⁸ working on the same problem under Professor Rogowski in Aachen were published. Paavola had extended Townsend's measurements to atmospheric pressure and to plate distances between two and five millimeters. Inasmuch as the present work promised further results at lower values of X/p in view of the greater plate distances involved, the work was continued with the gratifying results reported in this paper.

APPARATUS AND EXPERIMENTAL PROCEDURE

The experimental arrangement is shown in Fig. 1. The primary of the high tension transformer T was supplied by the 220-volt, 500-cycle a.c.

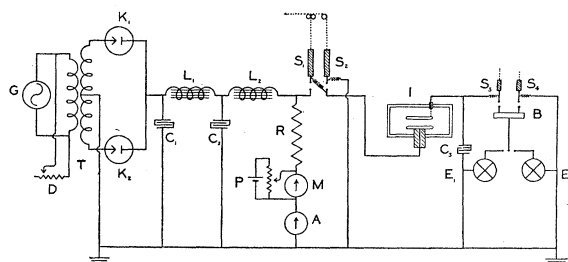

Fig. 1.

generator G which was operated by a 110-volt, 2-kilowatt d.c. motor. This motor was operated on the direct-current line, the voltage being held constant by means of a hot wire stabilizer.

The secondary of the transformer T was tapped at its center and connected to ground. The current was rectified by means of two General-Electric kenotrons of the KR-1 type. The filter system consisted of two condensers C_1 and C_2 of combined capacity 0.04 microfarads and two choke coils L_1 , L_2 , each of about 1000 henries inductance. As the maximum current drawn was 0.4 milliamperes the ripple was computed to be of the order of one one-hundredth of one percent or less which was considerably smaller than the possible errors in the voltage settings.

The voltage was measured by means of a bank R of 20 five-megohm resistors and the 2 millimeters M and A . The instrument A was a Weston milliammeter checked at the factory in August 1931, but as a further precaution it was calibrated over the range from zero to 0.4 milliamperes with a Wolff standard potentiometer, a Weston standard cell and a 1000-ohm standard resistance. It was found to be accurate over this range to within 1/4 of

⁸ Paavola, *Archiv f. Elek.* **22**, 443 (1929).

1 percent, no apparent consistent error existing. The resistors were also calibrated and found to be of an equal order of accuracy. The other milliammeter M which was of ten times the sensitivity of A was used merely as an amplifying device.

The switches S_1 and S_2 were used to connect the negative plate of the ionization chamber I either to the high potential or to ground. Both were fitted with platinum contacts and were mechanically connected together so that when one was opened the other was automatically closed. The upper plate of the ionization chamber I was connected permanently to the electrometer switch S_3 and to the sulphur-insulated, cylindrical condenser C_3 . The switch S_4 was connected permanently to ground and was used either to remove the charge from the working electrometer or to protect the instrument whilst measurements were being taken. The measuring instruments were the two Dolazalek electrometers E_1 and E_2 which were capable of covering a range of voltages varying from 0.01 volt to 100 volts. The two electrometers and the condenser C_3 were enclosed in a grounded chamber and all external leads to the electrometer system were carefully shielded in brass tubing and insulated with sulphur.

The capacity of the condenser C_3 was measured very carefully on a capacity bridge and the capacity of the ionization chamber and electrometer system measured for a number of different plate distances. This made it possible to compute the absolute values of the current. It also made possible a small but necessary correction to the voltage due to the fact that the ionization chamber and condenser C_3 formed a pair of condensers in series, so that the actual drop in potential across the gas was slightly less than that registered by the voltage-measuring instruments. This correction amounted to about 1 percent at a plate distance of 1 cm and decreased to less than 1/4 of 1 percent at the larger plate distances.

The ionization chamber I is shown in detail in Fig. 2. The case consisted of a cylindrical brass casting 45 cm in height and 50 cm in diameter, the inner surfaces being all heavily plated with tin. The lid rested on a lead gasket which was coated with stop-cock grease to ensure a vacuum-tight fit. The upper plate 20 cm in diameter was supported by a brass tube T from which it was insulated by a block of amber A . This tube was connected at its upper end to an iron armature F by means of a ball-bearing race. This armature revolved on the long screw S_1 which was connected to the top of the cylindrical housing H and could be turned by means of the magnet M . The magnet also revolved on the screw S_2 of the same pitch as S_1 so that the armature and magnet were always at the same height. By this means the upper plate could be set at any desired distance from the lower one. The rods RR were merely guides which kept the upper plate accurately in position.

In order to have the two plates always accurately parallel the lower plate was supported on a porcelain insulator I_1 resting on the circular plate P . This plate was connected to the lid by three rods with threaded ends and adjusted until the two plates were parallel to within a few hundredths of a millimeter. The lower insulator I_2 was made of Pyrex tubing and filled with pump

oil. It was ground to fit the taper in the bottom of the chamber and waxed into place. Contact was effected between the two leads passing through the insulators by means of a mercury cup in the top of the lower insulator. The upper plate was connected to the electrometer system by means of a gold chain *C* and a lead running through the amber bushing *B*. The distance between the plates was read by the use of a cathetometer through the glass window *G*. The ultraviolet radiation entered through the quartz window *Q* and fell obliquely upon the lower plate.

The whole interior of the chamber was carefully cleaned and the plates polished with jewellers' rouge before closing it for a set of observations. It was then exhausted to a pressure of about 10^{-3} mm. Lower pressures than this

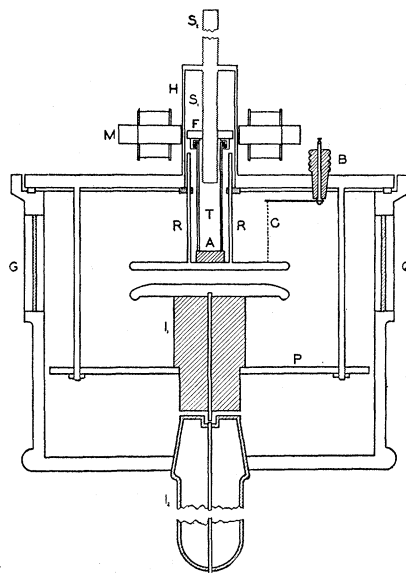

Fig. 2.

could not be attained on account of the vapor pressure of the mercury. The air was admitted slowly over a bank of drying tubes containing CaCl_2 , KOH and P_2O_5 . As a final precaution in ensuring perfectly dry air, the air was passed over a liquid air trap. The pressure could be regulated as desired. The original intention was to carry on the investigations at atmospheric pressure but on account of the high voltages required at the larger plate distances it was decided to use a pressure of 380 mm throughout the experiment. The actual pressure during the observations never varied more than $1/2$ mm from 380 mm.

The source of ultraviolet radiation was a Heraeus quartz mercury arc lamp operating on 220 volts. This was placed at a horizontal distance of 50 cm from the center of the lower plate and at a height of 5 cm above it. The light was rendered parallel by a quartz lens placed at its own focal length from the lamp and was admitted through a variable aperture of rectangular cross section. The horizontal aperture was 3 cm and the maximum vertical aperture

6 mm, which rendered the area of plate illuminated a rectangle 3 cm by 6 cm. This area lay well within the area, 14 cm in diameter, over which the field was uniform as determined below. The field between the plates was investigated by means of a full-size cross-section model of the plates immersed in a bath of electrolyte. An induction coil, telephone head set and exploring electrodes were used to find the equipotentials and it was found that the field was sensibly uniform over an area 14 cm in diameter. Thus, with the spot of light carefully focussed on the center of the lower plate, electrons could only be emitted in the portion of the field which was known to be uniform. For this reason no guard ring was used.

In order to keep the current through the mercury arc constant a current stabilizer was placed in series with the lamp. Even with these precautions there were occasional fluctuations in the photoelectric current which probably account for the large probable errors in some of the results.

The method of measuring the currents was as follows: The voltage was set at the desired value. Switch S_1 (Fig. 1) would be open and S_2 , S_3 , and S_4 all closed so that both plates of the ionization chamber, the condenser C_3 , and the working electrometer were all grounded. S_3 was then opened, thus isolating the upper plate and the condenser C_3 . S_1 was then closed, S_2 opening automatically so that the lower plate was raised to the negative potential indicated by the milliammeters M and A . The ionization current was allowed to pass for a known time (usually 10 seconds), then S_1 was opened, S_2 again closing automatically and grounding the lower plate. S_4 was then opened and S_3 closed, thus connecting the upper plate of the ionization chamber and the condenser C to the electrometer which measured the potential to which the condenser had become charged. This procedure was repeated four times for each voltage setting with the lower plate illuminated and once with the ultraviolet radiation cut off to insure the absence of corona discharge. The usual variation in current of the four readings was about 5 percent. The chance of a consistent error due to variation in voltage, photoelectric current, or timing was small. One advantage of this method was that any charge produced by the so-called *capacity current* mentioned by Paavola⁹ due to slight fluctuations in voltage was removed when the lower plate was grounded. Another was that the working electrometer was fully protected in case of breakdown of the gap.

In a preliminary series of measurements each run was taken at a constant plate distance, the current being measured as a function of the field. Observations were taken covering a range of plate distances varying from 1 to 3 cm at 2.5 mm intervals. This method had the advantage of giving values of the current for all possible fields from a few thousand volts up to breakdown. The disadvantage, however, lay in the fact that each run took seven hours to complete. During this time the photoelectric current was apt to vary greatly. Current-plate-distance curves were plotted from these data for values of X/p varying from 30 to 36.5.

Owing to the unsatisfactory nature of the preliminary results, resort was had to essentially the same method as that employed by Townsend in his

⁹ M. Paavola, *Archiv f. Elek.* **22**, 450 (1929).

original researches. A certain value of X/p was chosen and the currents measured as a function of plate distance over a range varying from 1.00 or 1.25 cm to as high as the voltage limits or the breakdown potential would permit. As a great deal of time was taken up in changing the plate distances, during which intervals the ultraviolet illumination was cut off, the decay in the photoelectric current was now found to be negligible. However, as an additional precaution against any consistent change in i_0 which might influence the slopes of the curves, the plate distances were chosen entirely at random.

EXPERIMENTAL RESULTS

The curves giving $\log_e i$ as a function of plate distance are shown in Fig. 3. The fact that these are all linear bears out the validity of the simple Town-

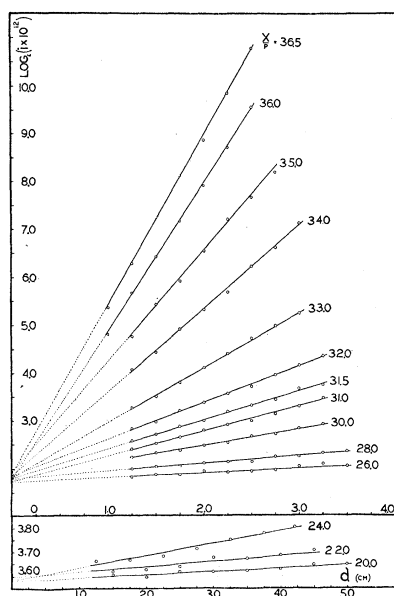

Fig. 3.

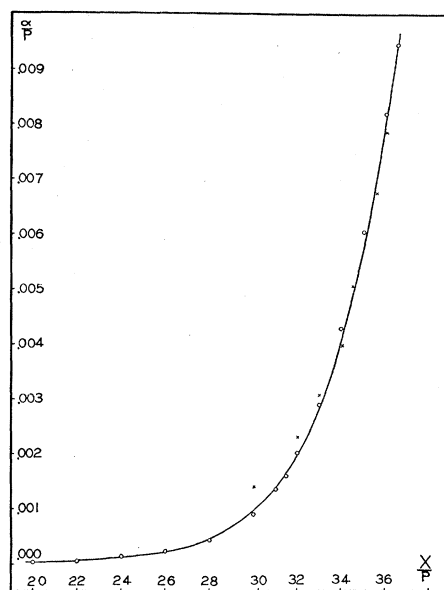

Fig. 4.

send Eq. (1). The value of the coefficient was obtainable directly from the slope of any one curve and the value of i_0 from the intercept with the axis of zero plate distance. These slopes and intercepts were first measured graphically but were later computed by the method of least squares. This eliminated entirely the personal bias which might occur in drawing the best straight line through any one set of points. For most of the curves the graphical and least-square solutions were found to check very closely. Below an X/p of 28 the points are rather more scattered. This is probably because the increase in current with plate distances is so small that variations due to other causes become evident. The probable errors here are accordingly quite large.

It will be noticed that the curves at X/p of 20, 22 and 24 have a larger value of i_0 than the remainder. This was necessary on account of the limitations of the measuring instruments. Although Townsend has shown that α is

independent of i_0 for plate distances below 1 cm it was thought advisable, in view of possible space-charge effects which might exist at these larger plate distances, to determine roughly whether or not the value of α was affected by a change in i_0 . Several curves were taken at X/p of 33 and 34 with widely different values of i_0 . No consistent change in the value of α was noted, which seems to justify the use of these larger currents.

In Fig. 4 the circles give the values of α/p as obtained by dividing the least-square solutions of the curves in Fig. 3 by the pressure, 380 mm. The crosses represent the values of α/p obtained graphically from the earlier set of readings taken at constant plate distances. It is seen that they check quite

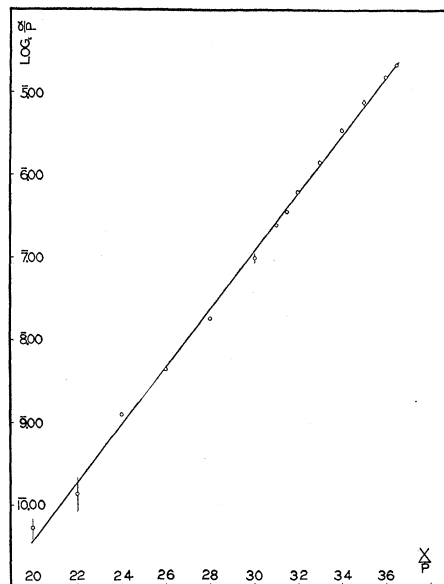

Fig. 5.

well above $X/p = 32$. Below this value the values indicated by the crosses are considerably greater than those indicated by the circles, but as mentioned before, the data here were too erratic to have much meaning. The curve represents a pure exponential relation of the form

$$\alpha/p = Ae^{bX/p}. \quad (4)$$

It was obtained as follows: The natural logarithms of the values of α/p indicated by the circles in Fig. 4 were plotted against X/p . The result is shown in Fig. 5 where it is seen that the points appear to lie on a curve very nearly a straight line. A least-square solution was again applied and is represented by the straight line in the latter figure. Knowing the slope and intercept of this line it was a simple matter to obtain the constants in Eq. (4). The constant b is merely the slope of the straight line and A is obtained by taking the anti-log_e of the intercept. The idea of plotting $\log_e \alpha/p$ against X/p was inspired by the fact that a rough curve through the points shown in Fig. 4 had the appearance of a pure exponential.

The probable errors of some of the observed values of α/p are shown in Fig. 5 as short vertical straight lines through the points. The values of the slope a_{11} and intercept a_{01} of the straight line with their respective probable errors are: $a_{11} = 0.3504 \pm 0.0032$; $a_{01} = 18.5615 \pm 0.0966$. This gives the values of the constants in Eq. (3) as: $b = 0.350 \pm 0.003$; $A = 2.67 \times 10^{-8}$.

The probable error in the case of A is not quite symmetrical on account of the fact that A is obtained by taking the antilog of the intercept a_{01} . The probable upper and lower limits to the value of A are respectively, 2.94×10^{-8} and 2.43×10^{-8} .

The interesting thing about this expression for α/p as a function of X/p is that α/p does not suddenly become zero at a definite value of X/p as found by Paavola but decreases in an asymptotic fashion with X/p . Whilst the values of α/p observed for X/p 's around 20 are very small they are certainly not equal to zero.

Another phenomenon noted in these measurements which has a definite bearing on the above was the lack of any definite saturation current. This is in good agreement with the work recently carried on in this laboratory by Dr. N. E. Bradbury¹⁰ on the nature of the photoelectric saturation current. Bradbury found that saturation of such currents cannot be obtained at field strengths below sparking. By extrapolation of Bradbury's equations to values of X/p in the neighborhood of 20 his results may be compared with the data obtained in these measurements. At $X/p = 20$ Bradbury's results give for $(d/dX)(i/I_0)$ where X is the field strength, I_0 the saturation current in vacuum and i the measured photoelectric current at a field X , an approximate value of 1.0×10^{-5} . The writer's work gives about 2.0×10^{-5} . In view of the extrapolated nature of the first of these values, numerical correction of values of α cannot be made. The indication, however, is that at values of X/p below 20 the natural slope of the photoelectric current produces a fictitious value of α which merges smoothly with the real values existing above $X/p = 20$.

The empirical expression found by Paavola to fit his observations is:

$$\alpha/p = 0.000156(X/p - 30.1)^2. \quad (5)$$

This would indicate that ionization by collision ceases to exist at lower field strengths than those corresponding to $X/p = 30.1$. As seen from the curves in Fig. 3, the slope of the curves below $X/p = 30$ is quite small and would be very difficult to detect over the small range of plate distances (2.0–5.0 mm) used by Paavola.

The actual values of α/p obtained in this investigation are considerably greater than those obtained by the above investigator as shown by the following table which also contains a few of Townsend's lower values:

X/p	20.0	26.0	26.9	30.0	30.1	33.0	33.5	36.5	37.0	40.0	40.4	45.7	50.0
α/p Townsend										0.0190			0.0550
α/p Paavola			0		0		0.00205		0.00703		0.0160	0.0407	
α/p writer	0.0000343	0.000234		0.00090		0.00289		0.00946					

¹⁰ N. E. Bradbury, Phys. Rev. **40**, 508 (1932).

The reason for this discrepancy is not apparent but it seems likely that with the greater resolving power of the apparatus used in this investigation the chances of error are somewhat less. The air used in the present work was carefully dried as previously described and kept at constant pressure. This was not entirely the case in Paavola's work. It is doubtful, however, whether this has any bearing on the above discrepancy.

As mentioned in the introduction, Townsend has suggested that the function $\alpha/p = f(X/p)$ takes the form:

$$\alpha/p = A\epsilon^{-Bp/X}. \quad (2)$$

This is a theoretical expression based on a deduction as to the mechanism of ionization which is not applicable to the present problem in the light of modern knowledge of ionization processes.¹¹ Townsend himself limits it to values of X/p above 300. Whilst it is an exponential form, it is entirely different from the empirical expression (4) and obviously cannot fit the present data for any values of the constants.

The phenomenon noted by both Townsend² and Paavola⁸ when the field is increased to within 3 percent of sparking, *viz.*, that the current increases with plate distance more rapidly than Eq. (1) would lead us to expect, was not observed in these measurements. At X/p of 36.5 and a plate distance of 2.5 cm the field was within less than 2 percent of sparking, yet there was no evidence of an abnormal increase in the current. Paavola noted this increase within 3 percent of sparking at plate distances of 4.5 and 5.0 mm. He also noted no current without ultraviolet excitation even on the verge of sparking. In the present investigation, currents were noted without excitation at a field slightly above X/p of 36.5. It may be that, at these greater plate distances, space charges build up and a corona discharge is produced preceding breakdown. The plates of the ionization chamber were carefully machined and polished so that there was very little chance of corona being produced by high fields at sharp points or edges.

With the care taken in these measurements it seems safe to assume that if such an increase in current actually exists as that ascribed to positive ion ionization it must occur at fields closer to the breakdown potential than 2 percent. This is completely in keeping with the values of β/p observed by Townsend,² who could not detect any measurable values of β/p at lower fields than those corresponding to X/p 100. It also agrees with recent information^{12,13,14} as to the inability of positive ions to ionize by impact at lower fields. It thus appears that the important factor in the early period preceding spark breakdown is the ionization by electrons and the subsequent distortion of the field by space charges to values where ionization by positive ions can occur. This must take place at values of X/p within 2 percent of sparking.

¹¹ J. S. Townsend, *Phil. Mag.* **45**, 1071 (1923).

¹² J. J. Thomson, *Phil. Mag.* **48**, 1 (1924).

¹³ L. B. Loeb, *Science* **66**, 627 (1927).

¹⁴ R. M. Sutton, *Phys. Rev.* **34**, 547 (1929). O. Beeck, *Phys. Rev.* **38**, 967 (1931).

In conclusion the writer desires to express his gratitude to the National Research Council for the financial assistance which in part made these investigations possible and his sincerest thanks to Professor L. B. Loeb at whose suggestion the problem was undertaken and under whose direction it was carried out. In addition the writer wishes to acknowledge his indebtedness to the mechanical skill of Mr. Wm. R. Stamper, without whose assistance in overcoming the many instrumental difficulties due to the large dimensions involved, the work could not have been brought to a successful conclusion, and to Mr. W. E. Bows for his assistance in taking readings.