

THE PHOTOELECTRIC EFFECT OF MOLTEN TIN*
AND TWO OF ITS ALLOTROPIC MODIFICATIONS**

BY ALEXANDER GOETZ

ABSTRACT

The photoelectric effect of molten tin and two of its allotropic modifications (β and γ) is investigated. An apparatus is described which permits the measurement of the photoelectric emission at the different changes of state. Because of the small photoelectric sensibility of tin, a Hoffmann electrometer had to be used with a sensitivity of ca 10^{-18} coul./sec. The range of temperature was 50° – 600° C. The range of wave-lengths from 2300\AA to 2900\AA . Taking all precaution to obtain monochromatic light and also taking into account the changes in the absorption of the metal, it was found that the photoelectric emission is independent of temperature as long as the phase of the cathode does not change. On the other hand, a change of state changes very definitely both its intensity and threshold, so that the denser the phase, the larger the work function. The threshold for liquid tin was found at $h\nu_0 = 2925 \pm 10\text{\AA}$; for γ -tin (hexagonal) $2820 \pm 10\text{\AA}$; for β -tin (tetragonal) $2740 \pm 10\text{\AA}$. The photoelectric curve of crystallization shows that the hexagonal modification starts to be unstable below $200^{\circ} \pm 2^{\circ}$ C; and, also, that the speed of transformation is very slow. On account of the fact that the transformation can be followed photoelectrically, it is possible to have a criterion for the cleanliness of the surface. It seems probable that the quantum-equivalent η_e changes also with the phase, so that the denser phase has the larger η_e .

THE photoelectric properties of metals in different phases (liquid and allotropic modifications) have not yet been studied with modern experimental methods so that it has not been possible to decide if there exists a change of the photoelectric constants.

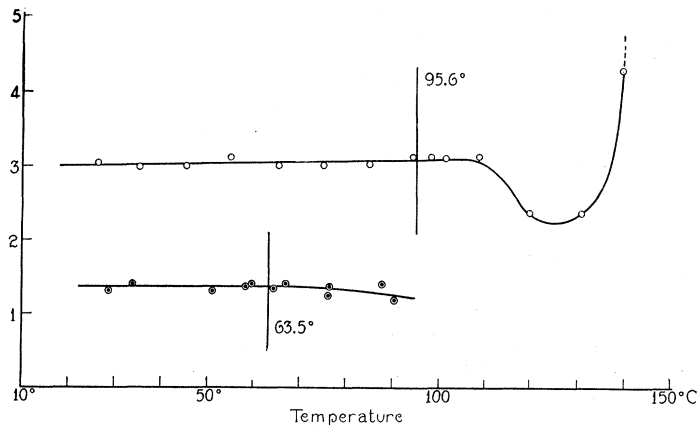

Fig. 1.

* A more detailed description of this subject will be published in the *Zeitschrift für Physik*.

** Reported at the meeting of the American Physical Society at Pasadena, Calif. December 8, 1928.

The only work which is published about this effect at the melting point is an early paper by Dember¹ dealing with Na and K. The results are shown in Fig. 1. The upper curve shows the values of I_T/I_t as function of T for sodium, the other showing the corresponding values for potassium, where T is the temperature of the cell in which the metal was melted, and t the standard temperature of another cell. There is a large decrease for the Na curve beginning 15° above the melting point, which the author ascribes to the change in the optical surface conditions. But on account of the fact that this author did not use monochromatic light the result cannot be interpreted. Similar investigations have been made by Pohl and Gudden² and Roller,³ both working at the melting point of mercury, but no satisfactory results were obtained.

Recently, Cardwell⁴ published a study of the photoelectric and thermionic properties of very carefully outgassed iron, finding a sudden change of the emission at the A_3 point of iron where the body-centered cubic lattice is transformed into the face-centered, but his observation left uncertain whether the change was due to a change in the red limit λ_0 or in the quantum-equivalent η_e .

The theoretical interest of this kind of investigation lies mainly in the question whether the photoelectric effect undergoes, in the transformation from one phase to another, the same alterations observed by Seiliger⁵ and the author^{6,7,8} for the thermionic emission in this case; since the work of DuBridge⁹ and Warner¹⁰ showed the same values for the photoelectric and thermionic work function of platinum and tungsten.

The experiment involved many difficulties, first because the metal had to fulfill unusual conditions which only tin can meet, and second because tin is a very inefficient photoelectric metal. These conditions are:

1. The melting point must be so low that the photoelectric effect can be measured far enough into the liquid phase without being disturbed by the beginning of the thermionic emission.
2. The melting point must be so high that one is not forced to go into regions of temperature where the lifetime of adsorbed gas layers is so long that the probability of obtaining a poisoned surface is too large.
3. The vapor pressure of each phase must be very small.

Tin is probably the only existing metal which fulfills all these conditions well, since its melting point is at 232° and its boiling point lies between 2000° and 2500° . Besides these qualities it has three allotropic modifications,

¹ H. Dember, *Ann. d. Physik* **23**, 957 (1907).

² R. Pohl and B. Gudden not published.

³ D. E. Roller, Thesis, California Inst. of Technology, 1928.

⁴ A. B. Cardwell, *Proc. Nat. Acad.* **14**, 439 (1928).

⁵ S. Seiliger, Dissertation Berlin 1926. *Zeits. f. Physik* **38**, 443 (1926).

⁶ A. Goetz, *Phys. Zeits.* **24**, 377 (1923); **26**, 206 (1925).

⁷ A. Goetz, *Zeits. f. Physik* **42**, 329 (1927).

⁸ A. Goetz, *Zeits. f. Physik* **43**, 531 (1927).

⁹ L. A. DuBridge, *Phys. Rev.* **29**, 451 (1927); **31**, 236 (1928).

¹⁰ A. H. Warner, *Proc. Nat. Acad.* **13**, 56, 1927.

of which two are in a safely accessible region of temperature, one being the common white β -tin with a tetragonal lattice,¹¹ the other the hexagonal brittle γ -form which exists near the melting point. The temperature of the alteration $\gamma \rightarrow \beta$ is not very well known and it is given by the following authors as: Tammann,¹² 203° (at 1000 Atm.); Cohen and Goldschmidt,¹³ 170°, 195°; Werigin, 175°, 161°; Smits and de Leeuw,¹⁴ 202.8°; von Simson,¹⁵ 100° (the lowest limit); Smits and Spuyman,¹⁶ 200.3°.

The optical reflectivity of tin is given by several authors. Results are shown in Fig. 2: R_1 being the reflectivity (in percent) measured by Erochin,¹⁷ R_2 by Kent¹⁸ for liquid tin, R_3 by Hulburt¹⁹ for sputtered tin. A_1 and A_2 show the corresponding absorption curves.

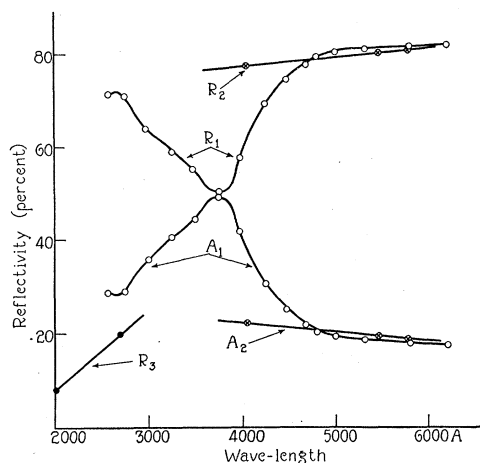

Fig. 2.

The photoelectric threshold of tin at room temperature—which always means the β -modification—is measured by Richardson and Compton²⁰ as 3620Å, by Hennings and Radesch²¹ between 2804 and 3132Å, by Hamer²² as 3185Å, and recently by Lukirsky and Prilezaev²³ as 3411Å. In none of these papers was a method used which really guaranteed a surface free from gas.

¹¹ M. Polanyi and E. Schmid, *Zeits. f. Physik* **18**, 75 (1923); *Naturwiss.* **11**, 256 (1923).

¹² G. Tammann, *Drude Ann.* **10**, 647 (1903).

¹³ E. Cohen and W. Goldschmidt, *Zeits. f. Physik Chemie* **50**, 225 (1905).

¹⁴ A. Smits and H. L. de Leeuw, *Verls. Akad. Amsterdam* **21**, 661 (1912).

¹⁵ C. von Simson, *Zeits. f. Physik. Chemie* **109**, 183 (1924).

¹⁶ A. Smits and J. Spuyman, *Verls. Akad. Amsterdam* **23**, 687; **29**, 327 (1921).

¹⁷ P. Erochin, *Ann. d. Physik* **39**, 213 (1912).

¹⁸ C. V. Kent, *Phys. Rev.* **14**, 459 (1919).

¹⁹ E. O. Hulburt, *Astrophys. J.* **42**, 205 (1915).

²⁰ O. W. Richardson and K. J. Compton, *Phil. Mag.* **24**, 576 (1912).

²¹ A. E. Hennings and W. H. Kadesch, *Phys. Rev.* **8**, 209 (1916).

²² R. Hamer, *Jour. Am. Opt. Soc.* **9**, 251 (1924); *Phys. Rev.* **20**, 198 (1922).

²³ P. Lukirsky and S. Prilezaev, *Zeits. f. Physik* **49**, 236 (1928).

The arrangement used for this investigation is shown in Fig. 3. The whole apparatus was so constructed that every sealed joint or greased stopcock, etc., was strictly avoided to prevent any chance of vapors of hydrocarbons because of the fact that photoelectric results are only reliable if this condition is fulfilled as perfectly as possible.

The cell *Z*, like the rest of the apparatus, consisted of Pyrex glass. Inside the cell was a cup *V* also made of Pyrex which was supported by the glass stem, through which a tungsten bar *W* was sealed so as to be vacuum tight. *V* contained tin, *W* making a good electric and thermal contact between the cathode and the outside of the tube. The outside end of *W* was welded to the joint of the thermocouple (Pt-Pt-Rh). By this means it was possible

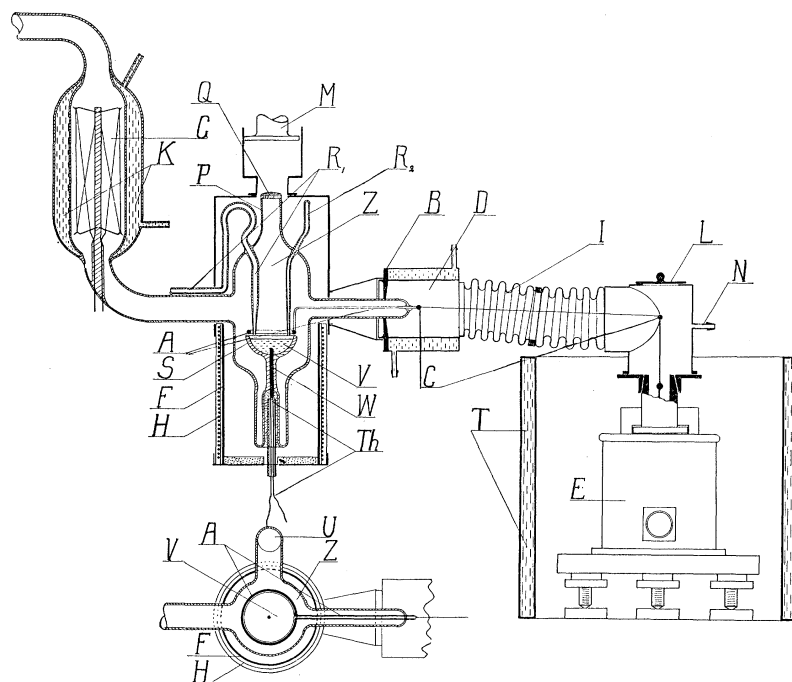

Fig. 3.

to measure the temperature of the cathode at the interior of the metal, which made it possible for one thermally to observe the whole act of crystallization or alteration of the modification. The anode consisted of a thin tungsten wire *A* bent to almost a circle and brought through the side tube to the outside of the cell by means of two Pyrex-tungsten seals. By this construction it was possible to heat the anode by current so that it was easy to outgas the anode at a much higher temperature than the cell would stand. The quartz window *Q* was sealed directly to the cell by means of a transition tube (quartz-Pyrex). The quartz lens on top of *Q* focussed the light from the monochromator *M* at the surface of the tin. The vacuum was obtained by a set of mercury pumps and measured by a dynamic resistance gauge *G*,

whose walls were cooled by means of the cooling jacket *K*. By means of an electromagnetic stop-cock between the liquid air traps and the pumps it was possible to separate the cell from the pumps without danger of adding any new vapors. A trap *U* filled with coconut charcoal permitted the absorption of gases when the cell was disconnected from the pumps. The position of the manometer *G* was such that every molecule which came from the cell had to pass through the gauge, causing there a cooling effect regardless of

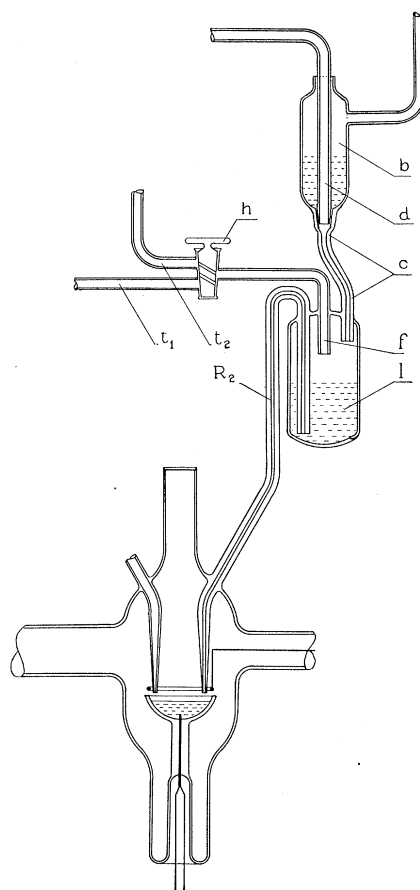

Fig. 4.

the static pressure in the whole apparatus. Thus the progress in outgassing the cathode could be followed rather accurately because it was only necessary to observe the changes which the resistance gauge indicated at the melting point of the metal. The sensitivity of the gauge was obtained by calculation and corresponded to 0.1 ohm per 10^{-7} mm.

Special care had to be observed in filling the cell with tin. The apparatus used for that purpose is shown in Fig. 4. After baking out the cell for 48 hours and reducing the molten tin in the tank *b* by carefully purified hydrogen

at 400°, the tin was filtered through the capillary tube *c* into the cup of the cell. By this kind of operation the tin went through a very effective reduction and was separated from the light impurities floating on the surface, as well as from the heavy ones sinking down to the bottom of the tank. After the cup was filled the apparatus was sealed off and then the cell was baked out for several weeks before the observations were taken.

The greatest difficulty was caused by the electric measurements, first on account of the high reflectivity of tin in the ultra-violet region, and second by its very small photoelectric sensitivity, which is also expressed by its position in the periodic system between Si and Pb, well known as the metals of the smallest photoelectric activity. Thus none of the usual methods of electrometric measuring was applicable, and it was necessary to use a Hoffmann electrometer,²⁴ which works in a vacuum and is able to reach the highest sensitivity of any electrical measurement. In this special case the highest obtained sensitivity was calculated as 10^{-18} coul. per sec. ± 50 percent which corresponds to a current between 15 and 20 electrons per sec. To avoid disturbances by free charges of the air it was necessary also to put the lead between cell and electrometer in a vacuum, so the lead had to be vacuum tight; it also had to be a perfect electric shield, flexible so as not to transmit vibrations from the glass apparatus to the electrometer, and a thermal insulator to prevent any conduction of heat from the hot cell to the electrometer. The capacity of this lead had to be less than 2 cm, which is the capacity of the electrometer. The flexibility was obtained by using the flexible seamless copper tubes *I*, soldered on both ends to the tubes *D* and *L*. *D* had a water-cooled jacket and was sealed with the copper plate *B* to the outlet tube of the anode. By means of this arrangement it was possible to keep the seal of the anode through the Pyrex at a constant temperature, thus avoiding thermoelectric forces. The part *L* was sealed to the electrometer *E*, and was connected by the tube *N* to the pump. The connection *C* between cell and electrometer consisted of a copper wire 0.05 mm in diameter. To keep the electrometer at a constant temperature and avoid any influence from the hot cell, *E* was surrounded by the water tank *T*.

The rise of the temperature of the cathode was accomplished by heating the entire cell, thus avoiding thermoelectric forces inside the cell and deposits of gas coming from the metal at the glass walls. Therefore the cell was surrounded by a furnace *H* which was put over a massive metallic tube *F*. This was in good electric contact with the rest of the electric shields to prevent induced charges by the heating current.

In order to facilitate the cleaning of the surface of the cathode from oxides the tube *R*₁ was constructed so as to make it possible to send a flow of highly purified hydrogen over the heated surface. This operation, when followed by a very intensive evacuation, should give a guarantee of a clean surface.

²⁴ G. Hoffmann, Ann. d. Physik 52, 665 (1917).

The electric connections are shown in Fig. 5. K is the cathode, Th the thermocouple, A the anode, N the system of the electrometer above the duants D .

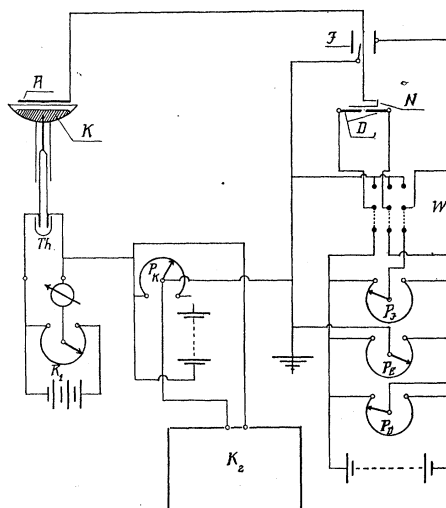

Fig. 5.

The temperature was measured by means of the potentiometer K_1 and a zero-galvanometer, and at the same time one part of Th was used to apply to the cathode a positive potential against the ground, which could be

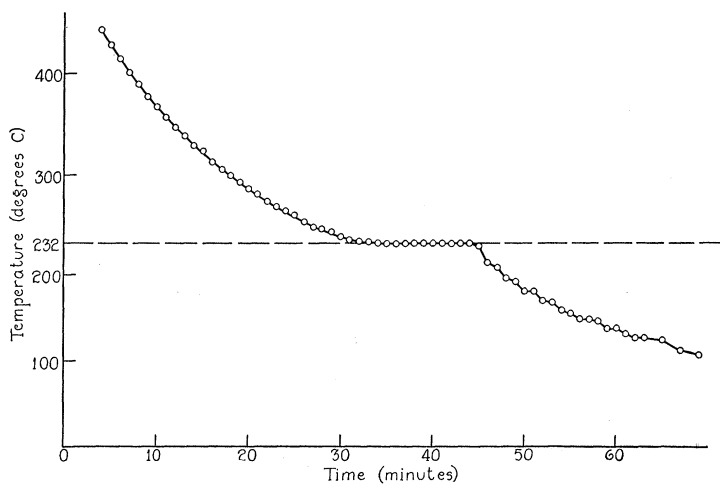

Fig. 6.

measured by the compensation apparatus K_2 . The potential of the duants, of the induction ring, J , and the relative position of the ground was adjusted by 3 potentiometers P_D , P_E , P_J , connected by the triple switch W .

The optical arrangement consisted of a mercury arc and a Hilger monochromator *M*, the first being carefully calibrated.²⁵

The cell was filled with liquid tin after a preliminary outgassing of 48 hours, this process being continued over at least 200 hours at 500° after sealing off the filling apparatus. Then the measurements were started.

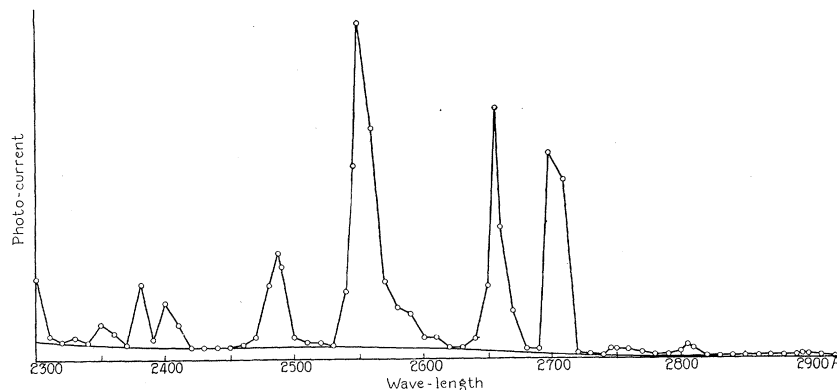

Fig. 7.

To avoid a poisoning of the surface of the cathode by the adsorbed amount of gas, purified hydrogen was let through the tube *R*₁ (Fig. 3) from time to time, thus reducing the surface at a temperature of 550°.

The cooling curve, Fig. 6, was then measured several times and showed irregularities below the crystallization which must be ascribed to the mentioned transformation from γ to β tin.

To measure the amount of scattered light the photoelectric emission was measured over the whole spectrum at 5Å intervals for liquid tin as shown in Fig. 7. Although the scattered light is immeasurably small (slit aperture of the monochromator 5 mil) in the part of the spectrum which is important for the determination of the thresholds, filters were used in this region but no difference was found.

Two kinds of measurements were taken, first the photoelectric emission at one particular temperature as a function of λ and second the photoelectric emission for one particular line as a function of the temperature. Fig. 8 shows the first curve for three different temperatures where one of the three phases is stable: I for liquid tin at 400°C, II for γ -tin at 210° and III for β -tin at 85°. The absolute values of the emission represented by these curves cannot be compared with each other. The curves with circles give the emission in arbitrary units; the curves with crosses show the corresponding values on the logarithmic scale of the ordinate, as shown in Table I.

These logarithmic curves enable one to extrapolate more exactly the curves in the neighborhood of the red limit, the latter being given by the section of the curve whose tangent is vertical, which allows a more exact

²⁵ Ch. B. Kazda, Phys. Rev. **26**, 643 (1925).

TABLE I. Absolute value of the photoelectric emission.

λ	Liquid tin		γ -tin		β -tin	
	$\log I-1$	I	$\log I-1$	I	$\log I-1$	I
2301	1.59	3.94	1.38	2.4	1.19	2.04
2378	1.35	2.24	1.18	1.50	1.31	1.30
2399	1.30	2.00	1.09	1.24	1.07	1.19
2482	1.275	1.26	0.943	0.878	0.854	0.715
2537	0.973	0.94	0.774	0.594	0.695	0.495
2653	0.695	0.496	0.480	0.302	0.235	0.172
2699	0.561	0.364	0.305	0.220	0.880-1	0.0758
2752	0.332	0.215	0.0607	0.115	—	—
2810	0.15	0.142	0.544-1	0.035	—	—
2893	0.54-1	0.035	—	—	—	—

plotting of the observations in the region of the disappearing current. The dotted lines in Fig. 7 show the tangents for the logarithmic curves. The red limits thus given for the different phases are shown in Table II.

TABLE II. Long-wave limit for three modifications of tin.

No.	Phase	λ_0 (A)	ϕ_0 (volt)
I	liquid	2925 ± 10	4.2
II	γ	2820 ± 10	4.38
III	β	2740 ± 10	4.51

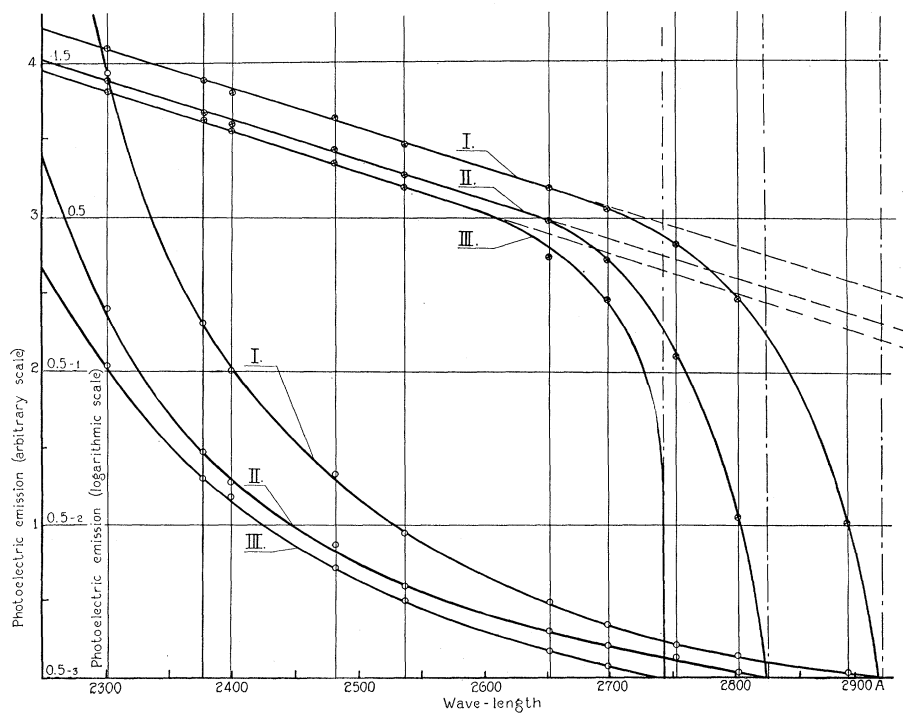

Fig. 8.

The interpretation of the results shown by the photoelectric cooling-curves for different lines is not as easy. From the curves in Fig. 8 one should expect for them three different types, shown in Fig. 9 *a*, *b*, *c*. The case *a* is expected for wave-lengths between λ_0 for liquid and λ_0 for γ -tin, i.e. there should be a region in the spectrum which excites only the liquid tin and none

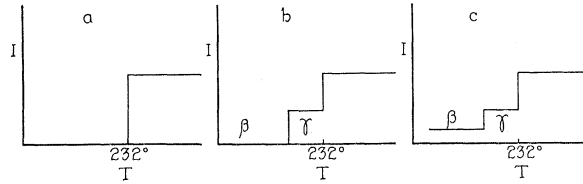

Fig. 9.

of its solid phases. Fig. 9*b* shows the expected effect for λ between λ_0 for γ and β , and 9*c* the cooling-curve for λ smaller than λ_0 for β . No change in the quantum-equivalent η_e at the transformation is considered in these curves.

The measured curves are shown in Fig. 10 (they are selected from ca. 4500 observations with the view to present all possible types of observed

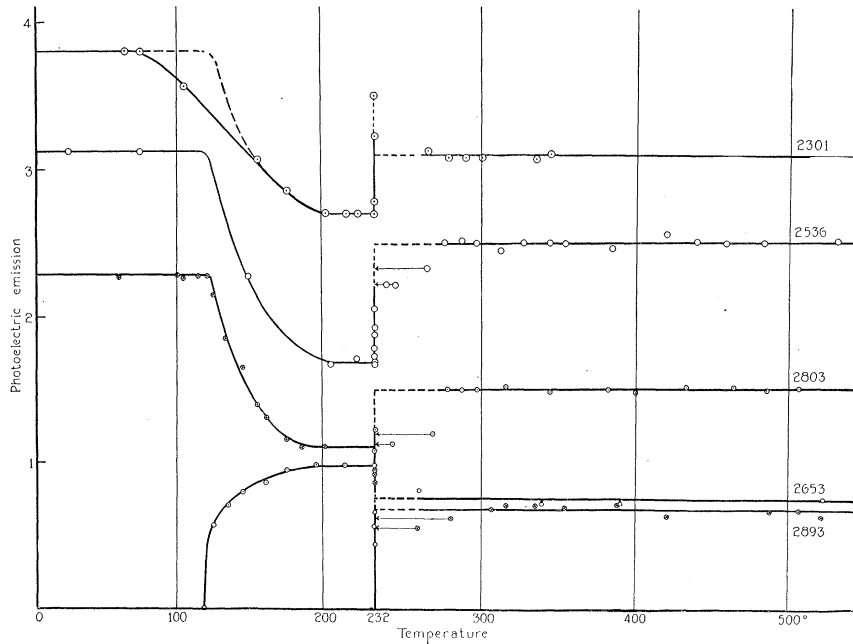

Fig. 10.

curves). The condition *a* is fulfilled for one line (2893A) of the spectrum used, which produced the curve marked with circles in Fig. 10. (The numbers 2893 and 2653 in Fig. 9 have to be interchanged). This curve is in perfect agreement with case *a*.

For the verification of 9*b* there are two lines ($\lambda=2803\text{\AA}$ and 2752\AA) which show exactly the same effect, wherefore but one is shown in Fig. 10 (2803). This shows the independence of the effect from temperature quite well for the liquid phase over 320° , a drop at the melting point, which is not sudden on account of the thermal lag between the cell and the metal, then a constant emission until 200° and then instead of a sudden disappearance, a slow decline until 120° .

The condition 9*c* should be fulfilled by all the rest of the lines used. The curve $\lambda=2536\text{\AA}$ in Fig. 10 is typical for this region. It looks exactly like the curve of the 9*b*-type for the liquid and the γ phase, but then it rises and reaches a constant value at approximately the same temperature where the other curve became zero. (This curve is one of eight which all showed almost exactly the same effect, therefore it is more certain than the observed points in the curve presented indicate). The curve $\lambda=2301\text{\AA}$ shows qualitatively the same effect but it is very possible that the observation at 102° is wrong.

A type of 9*c* which was observed rather seldom is given for the line $\lambda=2653\text{\AA}$ marked with crossed circles and differs from the ordinary type in that it indicates after a primary decrease of the emission a larger value for the β tin than for the liquid; but the transition from γ to β is the same as in the previous curves.

There are several conclusions one can draw from these results. First, all the curves in Fig. 10 show that *the photoeffect is independent of temperature over the interval investigated (50° — 600°C) as long as the phase of the cathode is constant*. Furthermore, the case 9*a* being perfectly fulfilled, there is a *change in the threshold between γ and liquid tin*. The same is true between the β and γ form but the observed curves show that *the transformation from γ to β goes slowly* so that a large undercooling effect can be observed. This is in agreement with the fact that the γ tin cannot be detected at all by heating tin up to the melting point; it is shown furthermore by the cooling-curve (Fig. 6) and it gives the explanation for the very different statements of metallographic authors, and could be almost expected from the well-known small speed of the β (white) $\rightarrow\alpha$ (gray) phase-transformation.

The fact that different values of the emission were observed for the solid phase after each crystallization can be explained only by the change of the structure of the surface. The area of the cathode was large compared with the image of the slit of the monochromator at the surface, the latter being ca. 0.5 mm wide. The facets produced by the crystallization had always a different position in relation to the image of the slit which changes the degree of "blackness"; i.e. the absorbed number of quanta is different for each crystallization and therefore the value of the emission of the solid phases relative to the emission of the liquid changes. An example of this fact is the curve 2653 where inspection showed a long groove across the cathode running almost parallel to the image of the slit. In this special case, the cathode acted almost as a black body and the efficiency of the photoeffect was large. In discussing these results one has therefore to distinguish be-

tween two components of η . One, η_0 , expresses the "blackness" of the surface and includes also the optical reflectivity shown in Fig. 2; the second describes the electric efficiency of the photoeffect—the quantum-equivalent η_e . The total efficiency is therefore $\eta = \eta_0 \cdot \eta_e$. But there is no way in this kind of measurement (using liquid surfaces) to separate η_0 from η_e directly.

One knows, on the other hand, from the measurement of the optical reflectivity, that there is not very much of a change between liquid and solid tin in the region of the spectrum used. The reflectivity seems to decrease continually with the decrease of λ . No measurement exists for this optical constant as a function of temperature and of a change in the modification. But one should not expect a large change, because the increase in volume at the $\beta \rightarrow \gamma$ transformation is very small. Assuming, therefore, that this change can be neglected, the increase in the photoelectric sensitivity can be explained only by an increase in η_e . The "blackness" of the surface may be changed also to some extent at this transformation, but this effect cannot be large, and especially would not explain that the emission of β -tin is *always* larger than the emission of γ -tin. *It seems therefore very probable that the quantum-equivalent for β -tin is larger than for γ -tin.* It is impossible to make any statement about the transformation from liquid to γ -tin because the change of η is there beyond control.

All these effects could be explained as an effect of gas layers at the cathode, whose conditions of stability are changed by a change in the structure of the cathode; and the history of photoelectric observations shows that even the largest number of precautions and the greatest care are sometimes no guarantee for the reliability of the results. But in this special case there is one effect which shows that a gas layer could *not* explain the results obtained: If the change of the emission were due to a gas layer which forms or disappears at the change of phase, it is inexplicable that the same layer results always in a desensitization at the long wave-lengths and in a sensitization at shorter ones. It would also be hard to explain on that basis that the emission is independent of temperature as long as the phase does not change. Hence it seems impossible that the effect could be caused by gas.

The values of λ_0 obtained for the β phase are much smaller than previous results. (s.a.) This may be an analogy to the decrease of λ_0 with increasing purification as it is observed on platinum.⁹ The results can be stated as follows: *The higher the temperature in which one special phase is stable, the smaller is its work function.* Fig. 8 shows that the photoelectric current for wave-lengths ca. 100Å smaller than λ_0 after correction for $d\eta_0/d\lambda$ can be expressed in a simple exponential law which is indicated by the linear nature of the logarithmic curves. The cooling-curves indicate that *the point of the transformation of $\gamma \rightarrow \beta$* is at $200^\circ \pm 2^\circ\text{C}$ which is in very good agreement with other authors.^{12,14,16} The speed of transformation is very low at 200° and the photoelectric measurement gives the possibility of measuring the decrease of the γ concentration in the β tin with time and temperature ($\lambda = 2803 \text{ Å}$); and independently the increase of the β component ($\lambda = 2536$) in the cathode.

Finally it is very probable that the *quantum equivalent increases with the increase of λ_0 at the $\gamma \rightarrow \beta$ transformation*, and there is no indication that the same does not occur at the melting point. This would give a very interesting analogy between the photoelectric and the thermionic constants, between b and λ_0 , A and η_e , because the author⁸ found for thermionic effects at the melting point that a change of b always goes together with a change of A , which produces a compensation of the final value of the emission. DuBridge²⁶ found recently that $\ln A$ is always a linear function of b for a particular material. Thus it seems to be possible that besides the known and certified identity of b and λ_0 there is an analogy between the thermionic A and the photoelectric quantum-equivalent η_e . But until now we have no other indication than the analogous change of both constants at the change of phase.

In conclusion, the author desires to express his appreciation of the kind interest which Dr. Millikan took in this work and his thanks to Mr. E. McMillan for the valuable help which he gave to the work for one year.

NORMAN BRIDGE LABORATORY OF PHYSICS,
CALIFORNIA INSTITUTE,
DECEMBER, 1928.

²⁶ L. A. DuBridge, Proc. Nac. Am. Nat. Academ **14**, 788 (1928).