

PROCEEDINGS
OF THE
AMERICAN PHYSICAL SOCIETY.

MINUTES OF THE WASHINGTON MEETING, APRIL 23 AND 24, 1920.

THE 103d regular meeting of the American Physical Society was held at the Bureau of Standards in Washington on April 23 and 24, 1920, President Ames presiding. There were about 250 members and friends in attendance.

At the meeting of the Council on April 23, attended by nine members, the following actions of general interest were taken: The Council voted that it is desirable to send abstracts of papers to the members in advance of a meeting, and a special committee was appointed to formulate the details of a practicable plan for so doing. There was created a standing committee on Education, whose functions shall include the arrangement of programs of papers and reports on educational matters and the general development of matters that pertain to the welfare and progress of the teaching of physics. The following persons were *elected to regular membership*: Stuart Ballantine, H. S. Osborne, and Frederick J. Schlink; the following were *elected to associate membership*: N. C. K. Aiyar, N. K. Chaney, L. T. Clark, W. M. Clark, C. T. Dozier, J. G. Ferguson, H. M. Fry, A. F. Gorton, M. E. Graber, E. J. O'Leary, F. N. McKown, F. MacMurphy, Wm. T. Parkerson, B. Perkins, W. B. Roberts, N. S. Robertson, Geo. Rosengarten, C. D. Spencer.

The following program of fifty-two papers was presented, four being read by title.

An Astatic Magnetometer of Variable Sensitivity. C. NUSBAUM.

Automatic Apparatus for Intermittent Testing. GEORGE W. VINAL AND L. M. RITCHIE.

Thermostat Performance. WALTER P. WHITE.

The Use of the Oscillograph for Measuring Short Time Intervals. H. L. CURTIS AND R. C. DUNCAN.

Some Refinements in a Chronograph. G. F. HULL AND E. A. ECKHARDT.

The Outward Motion of Air from a Telephone Receiver. HERBERT GROVE DORSEY.

The Relative Difficulty of Interpreting the Spoken Sounds of English. H. FLETCHER.

The Whine of a Shell. ARTHUR TABER JONES.

Photographic Study of a Bullet in Flight and of the Resulting Air Disturbances. D. C. MILLER, F. A. FIRESTONE, AND P. P. QUAYLE.

Production, Transmission, and Reception of Feeble Earth Vibrations. E. B. STEPHENSON.

Dispersion in Optical Glasses. F. E. WRIGHT.

A Method of Determining the Tensile Strength of Glass. J. T. LITTLETON.

The Expansion of Glass, at High Temperatures. W. R. PIETENPOL.

The Entropy of Gases and the Principle of Similitude. RICHARD C. TOLMAN.

The Third Law of Thermodynamics. GILBERT N. LEWIS AND G. E. GIBSON.

A More General Form of the Maxwell Distribution Law. GILBERT N. LEWIS AND G. E. GIBSON.

Volume Changes Accompanying the Transition of a Dental Amalgam Near 70° C. ARTHUR W. GRAY.

Results of Atmospheric-Electric Observations Made During the Solar Eclipse of May 29, 1919. S. J. MAUCHLY AND ANDREW THOMSON.

Effects of Differential Refraction in the Earth's Atmosphere upon Observed Light Deflections. L. A. BAUER AND W. J. PETERS.

Note on Electromagnetic Induction and Relative Motion. S. J. BARNETT.
(Read by title.)

An Integration Method of Deriving Alternating Current Resistance and Inductance of Conductors. H. L. CURTIS.

The Status of Ohm's Law. F. WENNER.

The Inductance of Coils on Polygonal Forms. FREDERICK W. GROVER.
(Read by title.)

A Modification of the Braun Electrostatic Voltmeter. J. E. SHRADER.

On the Use of Continuous Waves for the Measurement of Dielectric Constants of Liquids. W. F. POWERS AND J. C. HUBBARD.

An Extension of the Range of the McLeod Gauge. A. H. PFUND.

The Electric Spark—A Modified Method of Control. W. O. SAWTELLE.

Piezoelectric and Allied Phenomena in Rochelle Salt. JOSEPH VALASEK.
(Read by title.)

The Application of Rotatory Dispersion to Colorimetry, Photometry and Pyrometry. IRWIN G. PRIEST.

Color Match and Spectral Distribution. EDWARD P. HYDE AND W. E. FORSYTHE.

The Gold-Point Palladium-Point Brightness Ratio. EDWARD P. HYDE AND W. E. FORSYTHE.

A Note on the Temperature Shift in the Near Infra-Red Bands. H. M. RANDALL, W. F. COLBY AND R. F. PATON.

Transmission of Thin Films in the Extreme Ultra-Violet. ELIZABETH R. LAIRD.

The Luminescence of Samarium. HORACE L. HOWES.

The Resistance of a Gas to the Motion of a Sphere When the Mean Free Path is Large in Comparison with the Diameter of the Sphere. R. A. MILLIKAN.

The Existence of Homogeneous Groups of Large Ions. OSWALD BLACKWOOD.

Low Voltage Arc in Helium. K. T. COMPTON, P. S. OLMSTED, AND ED. J. LILLY.

The Crystal Structure of Carborundum. ALBERT W. HÜLL.

On the Absorption of X-Rays by Chemical Elements of High Atomic Numbers. WILLIAM DUANE AND R. A. PATTERSON.

The Mass-Absorption Coefficient of Water, Aluminum, Copper, and Molybdenum for X-Rays of Short Wave-Length. F. K. RICHTMYER AND KERR GRANT.

Photoelectric Effect of Alkali-Vapors and a New Determination of h . E. H. WILLIAMS AND JACOB KUNZ.

On the Photoelectric Long-Wave-Length Limit of Platinum and Silver. OTTO STUHLMAN, JR.

Measurement of Short Time Intervals in the Corona Discharge. CHARLES S. FAZEL. (Read by title.)

Color Sensitiveness of Photoelectric Cells. E. FRANCES SEILER. (Read by title.)

The Detecting Efficiency of the Electron Tube Amplifier. E. O. HULBURT AND G. BREIT.

The Detecting Efficiency of the Single Electron Tube. E. O. HULBURT AND G. BREIT.

The Calculation of Detecting and Amplifying Properties of an Electron Tube from its Static Characteristics. G. BREIT.

The Emission of Electrons from Oxide-Coated Filaments. C. DAVISSON AND H. A. PIDGEON.

The Ionization and Resonance Potentials of Nitrogen, Oxygen, and Hydrogen. F. L. MOHLER AND PAUL D. FOOTE.

The Load on the Modulator Tube in Radio Telephone Sets. E. S. PURINGTON.

Operation of an Electron Tube as an Amplifying Rectifier. LEWIS M. HULL. Capacitive Coupling in Radio Circuits. E. WHITEMORE.

The abstracts of all these papers are given on the following pages.

DAYTON C. MILLER,
Secretary.

AN ASTATIC MAGNETOMETER OF VARIABLE SENSITIVITY.

By C. NUSBAUM.

THE system consists essentially of two similar and rigidly connected magnets oppositely oriented in the same plane with the upper one centrally located in the axis of two Helmholtzian coils. The two magnets, each 1 cm. long and 0.5 mm. in diameter, are at a distance of 50 cms. from each other and supported by a quartz fiber 25 cms. in length. The suspended system weighs about 1 grams. The control field for the system is set up by a

permanent magnet which is perpendicular to and can be moved parallel to and concentric with the suspension of the astatic system. When the control magnet is in the position of lowest sensitivity the value of the control field is about one unit, while in the position of highest sensitivity it is one hundredth of a unit or less. In the former arrangement the period of the system is about 2 seconds and in the latter about 25 seconds. A variable air damping system is used so as to approximate to critical damping for the various sensitivities. The instrument is designed primarily for investigating the magnetic transformations of iron and steel at high and low temperatures and also the magnetic properties of steels as affected by different heat treatments.

BUREAU OF STANDARDS.

AUTOMATIC APPARATUS FOR INTERMITTENT TESTING.

BY GEORGE W. VINAL AND L. M. RITCHIE.

THIS apparatus has been devised to meet the needs of the Bureau in making tests of dry cells and storage batteries but is applicable to nearly any form of intermittent test requiring the closing of electrical circuits at regular time intervals. Two selective relays are controlled by a clock which furnishes an electrical impulse to one of them once every minute. The rotating shaft of this relay advances by $1/60$ of a revolution at each impulse from the clock. Once an hour this relay furnishes an impulse to the second relay, advancing the shaft of the latter by $1/24$ of a revolution. The first shaft, therefore, revolves once an hour, the second once a day and geared to the latter is a third shaft which revolves once a week. On these three shafts are placed suitable commutators, having platinum contacts, which open and close the test circuits at regular intervals. The apparatus as it is at present installed is making the following dry cell tests: flashlight test, the ignition test and the telephone test. It is designed also to control life tests of storage batteries.

As the contacts of the selective relays are closed, they operate the master relays of the respective circuits which in turn close the multiple switches for the individual battery circuits. As each master relay closes, an automatic counter indicates the number of the contact and a signal lamp is lighted to indicate that the circuit is closed.

Several different forms of multiple switches have been tried. A test board that can be readily adapted for flashlight batteries containing varying numbers and sizes of cells has also been constructed.

The particular advantages of this type of apparatus for making these tests are: (1) elimination of rapidly moving parts; (2) accuracy of the time intervals; (3) possibility of making a number of different tests simultaneously with the same apparatus.

BUREAU OF STANDARDS.

THERMOSTAT PERFORMANCE.

BY WALTER P. WHITE.

IN the ordinary mercury-contact thermostat regulator there is a backlash of the contact between wire and mercury; that is, the contact breaks for a lower temperature than that at which it makes. The equivalent, in degrees, of this backlash measures the sensitiveness of the bulb, and has sometimes been taken as a rough indication of the constancy obtainable from the thermostat. A far closer approximation (given by T. S. Sligh, Jr.) adds the temperature lag of the bulb at each end of the stroke. This, however, goes too far in the other direction. It is satisfactory if the total lag, expressed as a temperature difference, is not over twice the backlash equivalent, but already gives twice the correct result when the ratio of lag to equivalent is 20, a value often met in practise. The maximum inconstancy normally occurring in an ordinary thermostat for any given rate of heating is the periodic oscillation of temperature for equal resultant up and down rates. This oscillation is given by the equation:

$$\frac{\Delta U_B}{VL} = \frac{vT}{2vL} - \tanh \frac{vT}{2vL},$$

from which the ratio of vT , the oscillation, to the temperature lag, vL , or to the backlash equivalent, U_B , can be found for any ratio of ΔU_B to VL . V is the rate of heating due to the heater alone, v the instantaneous actual rate, here = $V/2$, L the time lag. If the temperature lag is 5 times the backlash equivalent the oscillation is 77 per cent. of their sum; if the lag is 50 times the equivalent the oscillation is only 38 per cent. of their sum, and 20 times the equivalent. The error in the mean thermostat temperature as the room temperature moves up and down is still farther from the value obtained by taking the oscillation as the sum of ΔU_B and VL . For $VL = 33\Delta U_B$ its largest probable value is $0.07VL$, against $0.5VL$, if the oscillation were the sum of ΔU_B and the two vL 's. This error is not given, in general, by any single equation, but was obtained by successive approximations. These calculations can not be applied to give an exact result, since ΔU_B varies continually and irregularly, but they furnish approximate guidance to the thermostat designer, and can be used to show how far it pays to go in simultaneously increasing both sensitiveness, ΔU_B , and lag, L , by increasing the diameter of the bulb.

The variations or errors may be increased, to a calculable amount, by the expansion of the bulb wall.

Values of the backlash have been observed from 200 μ in air to 3 μ in hydrogen. From 60 μ to 10 μ is probable in air.

With mercury in an iron tube not over 1 cm. in diameter the lag is nearly all in the water, and may be 3 times as great if the tube is glass. It follows that for an iron tube there is practically no difference of temperature between wall and mercury, and hence little reason for using expensive invar tubes to avoid the detrimental effect of bulb wall expansion, though some non-rusting metal is very desirable. With glass the mean temperature of the

wall may differ appreciably from that of the mercury, but the wall-expansion effect is still negligible for bulbs not over 1.5 cm. in diameter. An approximate formula for the lag in minutes, if D is the internal diameter of the bulb, is $D(0.8D + a) \div 60$ for mercury and $D(26D + a) \div 60$ for organic liquids, where a depends on the stirring, and may have a value of 2 for a metal tube, and 3 times as much for glass.

With increasing bulb diameter the lag gets larger, that is, worse, while the backlash equivalent improves or gets smaller. The calculation of the best bulb diameter evidently depends on length, size of capillary and cooling rate. As an illustration, with a millimeter capillary, with $V = 0.01^\circ$ per minute, and with a 20 cm. bulb length, the best diameter calculated from the above data for a mercury bulb is near 4 cm., for organic liquid near 1 cm. The ratio of VL to ΔU_B is not far from 3 in both cases. The maximum oscillation is 0.0034° for mercury and 0.006° for organic liquid. But the organic liquid, if used at all, should be in a long coiled tube. With 10 times the length and 0.5 cm. diameter the maximum oscillation is 0.002° , the same in sensitiveness, lag, and final results as for a mercury-filled bulb 2 cm. x 80 cm. For smaller capillaries and greater lengths the optimum diameter becomes smaller, with better performance. With a smaller value of V the optimum diameter and lag are larger, with better performance, and vice versa. With lag in the heater the optimum diameter and lag are larger in the bulb.

The Gouy oscillating-wire regulator avoids altogether the periodic oscillation which is the largest irregularity, and can be made to diminish the day-to-day variation because its indifference to lag allows a bulb of larger diameter and hence greater sensitiveness. Too large a lag, however, causes irregular action.

With heater very near the bulb something resembling a negative lag is introduced. The oscillations become short, as in the Gouy regulator, hence the steadiness is great, but the relative temperature of bulb and bath depends on the amount of heat supplied, and hence on the room temperature. In respect to the day-to-day variation, therefore, this arrangement may be very inconstant.

For rapid oscillations the above expressions for lag become less and less accurate, since we have a damped temperature wave moving in from the surface. For the best result above with organic liquid in the bulb, namely, $.002^\circ$ amplitude of oscillation with $V = .01^\circ$ per minute, the calculated penetration of the wave in the liquid alone is of the order of 0.5 mm.—a mere skin, in fact. Hence the performance depends mainly on period and bulb surface, regardless of volume or shape. The interior of the bulb is usually inert and negligible, except for the fact that the effect of bulb wall expansion increases with the relation of volume to surface, so that it may be desirable to flatten the bulb, or to use invar or even silica glass.

GEOPHYSICAL LABORATORY,
CARNEGIE INSTITUTION OF WASHINGTON,
WASHINGTON, D. C.,
April, 1920.

THE USE OF THE OSCILLOGRAPH FOR MEASURING SHORT-TIME INTERVALS.

BY H. L. CURTIS AND R. C. DUNCAN.

IN a research problem undertaken some time ago, it was desired to record the time at which a number of events occurred in such a way that the time intervals between events could be measured accurately. These events occurred at intervals of from 0.001 to 0.10 second apart, and in some cases the series of events extended over one or two seconds.

The G.E. oscillograph was used as the recording instrument. It was modified by the addition of a special timing system by means of which narrow lines of light are thrown across the film at regular intervals, thus ruling on it an equal time scale. While various devices have been used, the following is the simplest and the most satisfactory.

Thin aluminum plates are mounted on the prongs of a tuning fork so that one plate laps over the other. A narrow slot is cut in each plate parallel to the prong of the tuning fork and the plates adjusted so that when the fork is at rest a beam of light passes through the two slots. By means of a proper optical system, the beam of light is focused in a narrow line across the film. When the fork is vibrating the slots are in line with the light beam only as the prongs pass through their neutral position, or twice each complete vibration. Therefore by using a 500-cycle fork 1,000 flashes of light are thrown on the film per second.

Considerable trouble was experienced in driving the 500-cycle forks at sufficient amplitude. Satisfactory results, however, were finally obtained by driving them by means of a 100-cycle master fork. In this way the electromagnets of the 500-cycle forks are energized once every five vibrations and by careful tuning it is possible to get a double amplitude of nearly 2 mm. This is important as with a given width of slot the sharpness of the timing lines depends upon the amplitude of vibration. Examinations of the films indicate that under these conditions the time of the exposure which produces the timing line is very short, certainly not more than 0.00002 second. In order to eliminate any possible errors caused by the master fork, a relay is so arranged that as the exposure is made the driving current is broken and the timing forks, therefore, vibrate freely. A similar set-up consisting of 50-cycle forks and a 50-cycle master fork is used to rule slow moving films into 100ths of a second.

If the plates on the fork are not accurately adjusted so that the effective width of the slot is a maximum when the prongs of the forks are at rest, every alternate timing interval will differ slightly from the intervening ones. Careful examinations of the films show that this is usually the case, although the differences amount to only about 2 per cent. of the average distance between lines and cannot be detected without the use of a comparator. Errors from this cause are overcome by interpolating between alternate lines, but this is necessary only when extreme accuracy is desired.

In order to test the accuracy which could be obtained in the determination of time intervals, films were exposed on each of two oscillographs simul.

taneously. A current interrupted by a contact on a tuning fork was allowed to flow through one of the recording galvanometers of each oscillograph, which were connected in series. By examining the two films it was possible to identify the individual interruptions in the current record. Measurements were then made on both films to determine values of corresponding time intervals. The results showed that after corrections were made for a slight difference in the vibration rates of the two forks, values of corresponding time intervals determined from different films varied in every case by less than 0.00001 second. The intervals measured varied from 0.001 second to 0.100 second.

The method has been used in the determination of the velocity of projectiles for measuring the time required for a projectile with a velocity of approximately 2800 ft./sec. to move a distance of 2 ft. The corresponding time interval is approximately 0.0007 second. Measurements of 15 of these intervals which were measured independently from records taken simultaneously on two different oscillographs showed a maximum difference of 4 millionths of a second and an average difference of 2 millionths of a second.

The addition of this timing system to the oscillograph makes it possible not only to record the time of the occurrence of a number of events but also to measure the corresponding time intervals with an absolute error of less than 0.00001 second.

BUREAU OF STANDARDS,
WASHINGTON, D. C.,
April 8, 1920.

SOME REFINEMENTS IN A CHRONOGRAPH.

BY G. F. HULL AND E. A. ECKHARDT.

THE characteristics of this chronograph are: A tuning fork operated by electric valve tubes and which can be calibrated to any desired degree of accuracy, gives very fine lines a thousandth of a second apart on a photographic film running two meters per second. The drum can spiral so that a record of a second can be obtained. A string galvanometer with very fine copper wires 0.0006 inches diameter is a sensitive recorder of the event desired.

ORDNANCE DEPARTMENT,
BUREAU OF STANDARDS.

THE OUTWARD MOTION OF AIR FROM A TELEPHONE RECEIVER.

BY HERBERT GROVE DORSEY.

THE longitudinal pressure of sound waves has been shown by Wood¹ and by Hall.² As early as 1878 Dvořák and also Mayer discovered that a resonator may be repelled by sound waves and Dvořák also showed that the pressure inside of a resonator is increased when excited by sound waves.

¹ PHYS. REV., Vol. 20, p. 113.

² PHYS. REV., Vol. 28, p. 385.

About nine years ago the writer observed that when an ordinary telephone receiver was excited by a rather strong alternating current of from 2,000 to 3,000 cycles per second, a unidirectional air current was blown from the receiver with sufficient velocity to immediately extinguish a lighted match. The blowing continues as long as the current and as the match flame was always blown outwards it is evident that air passes in to replace that which is expelled.

This unidirectional outward effect may be easily shown with much smaller currents, and with frequencies as low as 60 cycles per second by fastening to a tiny shaft in jeweled bearings a mica plate or door, which is then parallel to the telephone diaphragm, covers the aperture to the cavity in front of the diaphragm, and may swing outwards and upwards about a horizontal axis parallel to the diaphragm. The reason for the shaft as described is to avoid any confusion of rotation of the plate similar to the motion of Rayleigh's disk.

When the telephone receiver is excited by an alternating current the plate swings outwards and remains out as long as the current is on. There may be vibrations in the plate of the same frequency as the sound, but *the plate as a whole swings outwards*. By fixing a mirror to the plate the motion is readily visible by the deflection of a beam of light. Or an electric circuit may be operated by the motion of the plate, thus forming an alternating current relay. To such an instrument the author has applied the name *Sonelek*. The instrument becomes more sensitive and selective if the cavity is a resonator to the frequency of the alternating current used, and still more so if a resonator is placed in front so that the plate is repelled by the telephone and attracted by the resonator.

If *Sonelek* is tilted forwards so that the plate hangs one or two millimeters in front of the aperture and a whistle of the proper pitch to correspond to the frequency of the cavity considered as a resonator, is blown externally, the plate promptly swings inward to close the opening. Thus, if the effect be due to longitudinal pressure of sound waves, or to unidirectional air currents produced by this pressure, the motion in either case is away from the source of sound.

GLOUCESTER, MASS.,

April 6, 1920.

THE RELATIVE DIFFICULTY OF INTERPRETING THE SPOKEN
SOUNDS OF ENGLISH.

By H. FLETCHER.

I^N connection with the study of the telephonic reproduction of speech the errors in the interpretation of spoken sounds, which were transmitted over an electrical transmission system which reproduced these sounds with very little change in their quality and with received intensities which could be varied through a very wide range, have been determined. The method used may be briefly stated as follows: A caller reads aloud lists of monosyllables to listeners who write the sounds which they think are spoken. Their completed

lists are then compared with the called lists to determine what errors in interpretation were made.

Thirty-six vowel and consonant sounds were chosen as representative of the English language. These sounds were combined into simple monosyllables having the three forms: Consonant-vowel, vowel-consonant and consonant-vowel-consonant. All possible combinations which could be distinctly pronounced were formed. They were then arranged into lists of 50 syllables each, so that each of the vowel and consonant sounds occurred approximately the same number of times in each list. To include all the possible combinations mentioned required 176 such lists.

The tests were carried out in sound-proof rooms to eliminate interference due to noise. A definite testing routine was established and a training period of two or three weeks for the callers and observers was allowed before the results were considered reliable. Both male and female callers and observers were used. The results given below are averages obtained with two callers and eight observers. A diagram of the electrical transmission system is shown in Fig. 1.

It consists essentially of a condenser-transmitter,¹ vacuum tube amplifiers

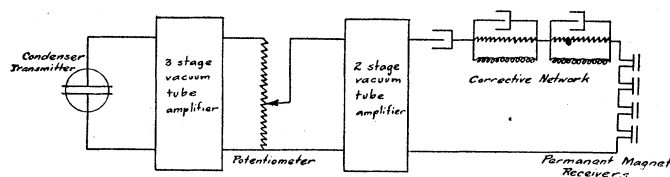

Fig. 1.

a potentiometer, a corrective network and a set of highly damped permanent magnet receivers. The corrective network was for the purpose of making the reproducing efficiency of the system the same for all frequencies.

For convenience, the receiving intensities of the speech sounds have been expressed in attenuation units. Let the received intensity of the speech sounds when the ear is placed close to the mouth of the speaker be called the "initial speech intensity." If α is the attenuation and ρ the intensity of the sound which enters the ear and ρ_0 the initial speech intensity, then

$$\frac{\rho}{\rho_0} = e^{-2\alpha},$$

The potentiometer was constructed to give a range of volumes from 10 times greater to 10^{-10} times less than the initial speech intensity, corresponding approximately to a difference in attenuation of 13 units.

Articulation tests were made with this electrical system for ten different volume conditions. The results obtained are shown by the curves in Fig. 2. The ordinates represent articulation and the abscissas, attenuation units.

¹ See articles by E. C. Wentz and I. B. Crandall in the *PHYSICAL REVIEW*, July, 1917, and June, 1918.

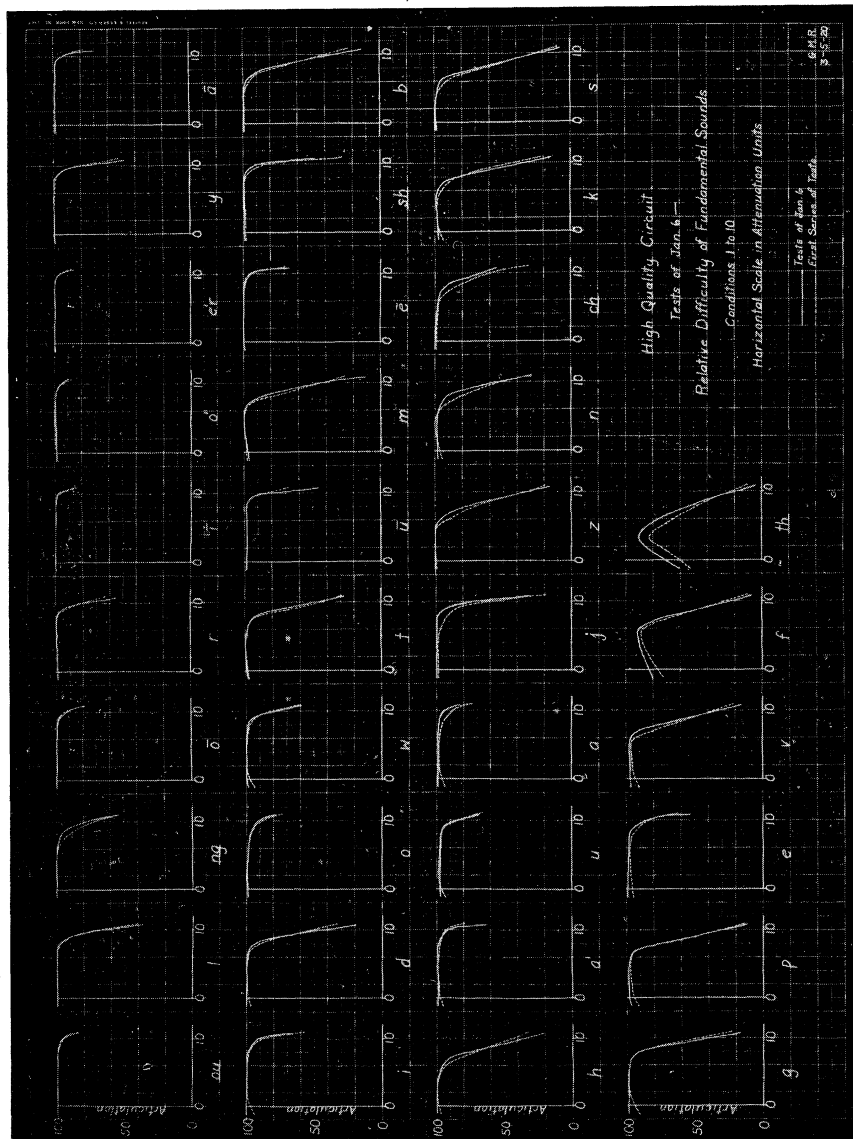

Fig. 2.

H. FLETCHER.

Speech Sound.	Key Word.	Articulation.			
		Very Loud.	Average.	Weak.	Very Weak.
l	(look)	100.0	99.8	99.1	31
i	(time)	99.6	99.8	99.7	92
ou	(town)	99.8	99.7	100.0	91
ng	(sing)	99.8	99.7	97.0	67
r	(red)	99.4	99.7	99.6	71
z	(zest)	99.4	99.7	84.0	25
ér	(term)	99.6	99.6	99.6	92
y	(you)	99.5	99.6	99.3	67
ō	(tone)	99.1	99.5	99.3	87
d	(day)	98.1	99.5	97.0	37
i	(tip)	97.0	99.4	99.0	75
t	(ten)	98.7	99.4	93.0	38
m	(man)	97.2	99.3	95.0	31
j	(jump)	99.4	99.2	97.0	46
o	(ton)	98.8	99.2	97.0	83
ó	(talk)	97.3	99.2	99.0	91
w	(we)	95.9	99.1	99.0	72
ā	(take)	98.7	99.0	99.2	84
g	(gold)	97.8	99.0	96.0	32
a	(top)	96.7	98.9	97.0	85
b	(ball)	99.4	98.9	91.0	27
n	(no)	96.1	98.9	92.0	42
ē	(team)	99.1	98.8	99.2	81
h	(hat)	98.3	98.8	84.0	35
sh	(ship)	98.3	98.5	99.1	62
á	(tap)	97.0	98.5	98.0	82
ch	(cheap)	99.5	98.2	93.0	55
s	(say)	98.7	98.2	80.0	17
k	(keep)	95.5	98.2	92.0	28
ū	(tool)	99.1	97.8	98.0	73
u	(took)	95.1	97.5	96.0	77
p	(pay)	93.9	97.5	91.0	21
e	(ten)	96.7	97.2	96.0	73
v	(view)	93.9	96.1	84.0	27
f	(fall)	80.3	87.3	76.0	17
th	(then)	56.3	82.7	61.0	14

To show the accuracy of the results, two series of tests were taken. The dotted curve represents the first, and the solid curve, the second series. In general, in the second tests there had been a slight improvement in the ability of the group to interpret the sounds.

It is seen that the best interpretation is obtained for intensities approximately one thousandth of the initial speech intensity. In the accompanying table the results are grouped into four intensities, called "very loud," "average," "weak" and "very weak." Expressed in terms of ratios of the initial speech intensity, these conditions correspond approximately to 10 , 10^{-3} , 10^{-6} and 10^{-9} . The threshold of audibility was found to be approximately one twentieth of the intensity of very weak volume condition.

These results are averages obtained by observing each speech sound approximately 1,000 times for the average, weak, and very weak conditions and approximately 500 times for the loud condition. It will be noticed that the consonants are usually harder to hear than the vowels. However, the speech sounds "e" and "l, r, ng" form notable exceptions to this general rule, since the former is among the most difficult while the latter are among the very easiest speech sounds. At all intensities, the sounds "th," "f" and "v" are the most difficult. "z," "h" and "s" become very difficult at weak volumes. The sounds "i," "ou," "ér" and "ó" are missed less than 10 per cent. of the time, even with very weak intensity.

RESEARCH LABORATORIES OF THE AMERICAN
TELEPHONE AND TELEGRAPH COMPANY
AND WESTERN ELECTRIC COMPANY, INC.

THE WHINE OF A SHELL.

BY ARTHUR TABER JONES.

THE whine of a shell is probably produced in the same manner as an æolian tone, *i.e.*, by the vortices which follow in the wake of the shell. For æolian tones Strouhal¹ found experimentally that the frequency is proportional to the velocity and inversely proportional to the diameter of the wire. If this relation holds up to the speeds attained by modern shells, and if the proportionality factor is about the same for a shell and for a wire which moves sidewise and has the same diameter as the shell, then a 75 mm. shell flying at 500 m./sec. would give a note in the neighborhood of e_5 , *i.e.*, a little more than two octaves above middle c , a 6-in. [15.23 cm.] shell flying at 700 m./sec. would give a_4 , and a 14-in. [35.6 cm.] shell flying at 900 m./sec. would give b_3 .

These pitches will be greatly modified in accordance with Doppler's principle. The first sound to reach the observer will be the bow wave. This will reach him at the same time as the sound propagated at the normal velocity from a point of the path which Labouret² has called the "initial center of sound." For a short time following this instant two sounds will reach the observer simultaneously—one from part of the path behind the initial center and the other from part of the path in front of the initial center. Both of these sounds will be modified in accordance with Doppler's principle. Auerbach³ states that Doppler's principle does not apply when the source approaches the observer with a velocity greater than that of sound. But if a source is at the tail of a shell it is quite possible that Doppler's principle would still apply.

The effect to be expected has been calculated as follows: The path of the shell is assumed to be a parabola, and the observer is assumed to be in the plane of this parabola. The rate at which the distance from the shell to the observer is increasing is calculated for a number of different instants. For

¹ Wied. Ann., 5, p. 216, 1878.

² Comptes Rendus, 106, p. 934, 1888.

³ Winkelmann, Hdbuch. d. Physik, ed. 2, Vol. 2, p. 586.

each of these rates the change of pitch due to the Doppler effect is calculated. This pitch is corrected by assuming that the frequency of the disturbance just behind the shell is proportional to the speed of the shell, *i.e.*, that Strouhal's law holds. The times at which the sounds from the different points of the path reach the observer are found, and curves are plotted coordinating the observed pitch with the time at which it is observed. The muzzle velocity of the shell is taken as 700 m./sec. and the velocity of sound as 350 m./sec. The abscissas give the times for each curve in seconds from the instant when the shell leaves the gun until the pitch in question is heard. The ordinates give the pitches in cents (1,200 of which make an octave) above the pitch which would be heard if there were no Doppler effect. The number on each curve gives the distance of the observer from the gun as a fraction of the range of the shell. Curves 1, 2, and 3 are for an angle of elevation of 20° and curve 4

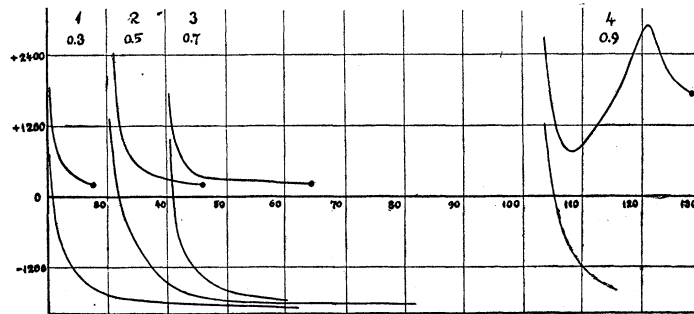

Fig. 1.

for an angle of elevation of 45° . In each case the upper branch of the curve is produced when the shell is approaching the observer at a velocity greater than that of sound. This upper branch ends—at the heavy dot—with the sound given out by the shell immediately after leaving the gun. The velocity of the stream of vortices which form the source of sound behind the shell is doubtless less than the velocity of the shell. This has not yet been taken into account.

Only in the case of curve 4 is there any approach to a rise of pitch followed by a fall of pitch—which I understand is often heard. These curves give no indication of any possibility of detecting by ear whether the observer is nearly underneath the vertex of the path.¹

The theory of æolian tones has been given only for the case of two dimensions,² and it is quite possible that Strouhal's equation does not hold for a body of the shape of a shell, even at low speeds. If we think of the shell as leaving behind it a tubular vortex sheet we see that this sheet will split up into

¹ Kreisler, *Four Weeks in the Trenches*, pp. 26-29.

² Kármán and Rubach, *Physikal. Zeitschr.*, 13, p. 49, 1912. Krüger and Lauth, *Ann. d. Physik* (4), 44, p. 801, 1914.

separate vortices. But just how these vortices can arrange themselves to form a stable configuration is not clear. It is very possible that in the three-dimensional case the effect of the pressure and temperature of the air may be more important than they appear to be in the two-dimensional case,¹ and therefore that the pitch given by a shell may depend to a considerable extent on the distance above the ground.

SMITH COLLEGE.

PHOTOGRAPHIC STUDY OF A BULLET IN FLIGHT AND OF THE RESULTING
AIR DISTURBANCES.

BY D. C. MILLER, F. A. FIRESTONE AND PHIL. P. QUAYLE.

AN extended series of photographs of the service bullet of the Springfield rifle in flight has been made by the well-known electric spark method. By using a mechanical trigger for the illuminating spark a relatively large time lag was secured which permits a large field of view free from wires, spark gaps, etc. The photographs show the bow and stern waves and wake particularly well developed.

The bow and stern waves, behind the bullet, are quite straight and parallel and are propagated in the direction corresponding to the relative velocities of the projectile (2,720 feet per second) and of sound (1,123 feet per second at the temperature of these experiments). Near the projectile the bow wave increases in velocity, probably due to the heat developed by the projectile and by the compression, until its velocity equals that of the projectile itself. The stern wave, immediately behind the projectile, has a diminished velocity, probably due to the cooling of rarefaction of the air; this velocity increases rapidly up to the normal velocity of sound, when the stern wave becomes parallel to the bow wave.

The wake is a very strongly developed and well defined turbulence which is dissipated very slowly. At a distance of ten bullet-lengths behind the bullet it is about twice the diameter of the bullet in cross section.

The bow and stern wave each consists of one condensation and one rarefaction which together make a nominal wave-length of about one millimeter. Photographs of the bow-wave made with the phonodeik show that the almost instantaneous increase in pressure is of very considerable magnitude.

This study is for the purpose of learning the relation between dimensions of projectile and the wave-length, frequency, pressure, and form of waves in air produced by the projectile, and will be used in connection with the investigation of the sounds from large guns and projectiles which forms the subject of another report.

CASE SCHOOL OF APPLIED SCIENCE.

¹ Rayleigh, *Phil. Mag.* (6), 29, p. 433, 1915.

PRODUCTION, TRANSMISSION, AND RECEPTION OF FEEBLE EARTH VIBRATIONS.

BY E. B. STEPHENSON.

1. *Detectors of Feeble Earth Vibrations.*—The primary problem was the development of a detection apparatus that would be light, strong, portable, sensitive, selective over a certain range of frequencies but having a true sound spectrum within that range, and constant in quality so that comparative tests could be made. Previous work in this field had been concerned chiefly with vibrations of large energy content like earthquakes and the apparatus available was some form of seismoscope or seismometer. The human ear has many advantages in selectivity and recognition over any type of visual or recording apparatus, so two types of listening apparatus have been developed—the *geophone*, developed originally by Professor Perrin of Paris and on which have been made only minor improvements, and the *telegeophone* or subterranean *microphone* which involves new modifications and is materially superior to any former apparatus of its type.

2. *Production of Feeble Earth Vibrations.*—The amplitude of the vibrations produced in the surface layer of the earth by a blow, say of a pick in clay, is not a simple function of the energy of the blow, but is a complicated function of the energy and the rate at which the energy is delivered.

3. *Transmission of Feeble Earth Vibrations.*—The feeble earth wave transmitted in a quasi-elastic medium near the surface and over short distances has the major portion of its energy in waves of frequencies between 10 and 100 cycles per second with an average of about 70 or less, a variable velocity depending on the material and its homogeneity but averaging about 4200 ft. per second, and an amplitude of a micron or less.

OFFICE CHIEF OF ENGINEERS,
WAR DEPARTMENT,
WASHINGTON, D. C.

DISPERSION IN OPTICAL GLASSES.

BY F. E. WRIGHT.

IF for each member in a series of optical glasses two partial dispersions, $(n_1 - n_2)$ and $(n_3 - n_4)$, be plotted as rectangular coördinates, the locus of the points obtained is a straight line, the departures from this line rarely exceeding one in the fourth decimal place. This indicates that the ratio of the excess partial dispersions of one optical glass over those of another for two different parts of the spectrum respectively is a constant depending only on the wavelengths involved. Computation shows moreover that the logarithm of the excess refractivity of the one glass over that of the second for a given wavelength varies with the square of the frequency. It is thus possible to set up a series of standard dispersion curves such that if one dispersion be given, the entire dispersion curve is fixed. This signifies that the glass maker is restricted in his efforts practically to the fitting of different refractive indices to a given

dispersion curve. A new two-constant dispersion formula based on the above relations is

$$n_1 = ae^{1/\lambda^2} + \frac{.00854}{\lambda^{0.9}} + b,$$

in which a and b are constants. This tentative equation furnishes refractive-index values correct in general to a few units in the fifth decimal place; in isolated instances, however, the difference may amount to one and even two in the fourth decimal place.

GEOPHYSICAL LABORATORY,
WASHINGTON, D. C.,
April, 1920.

A METHOD OF DETERMINING THE TENSILE STRENGTH OF GLASS.

BY J. T. LITTLETON.

THIS work was designed in order to get a measure of the tensile strength of glass, independent of surface conditions. As is well known, the slightest defect in a glass surface, even of microscopic size, may have a very large effect on the strength of the glass. It is due to these defects that no uniformity of results can be obtained.

This method proposes to eliminate the surface effect by throwing large initial strains into the surface layer of the glass, in such a manner that they resist the applied load. As a result, the region of greatest tension exists at some internal point and it is at this point that the fracture will occur. Since glass is very much stronger under compression than under tension, this method is possible.

A glass slab at a temperature above the annealing temperature is suddenly chilled, the surface layer thrown under compression and the inner part under tension. A rectangular bar, cut from this slab, is supported on knife edges at the ends, and loaded at the center until fracture takes place. The initial stresses are measured by means of a calibrated quartz wedge compensator and are plotted on cross section paper. The breaking stress curve is then combined graphically with the initial stress curve, and the point of fracture and the amount of stress at that point are determined.

A variation from the mean of an accuracy equal to that of the error of the apparatus is thus obtainable, which is approximately five per cent. Similar tests on annealed specimens show a mean variation of twenty to forty per cent.

CORNING GLASS WORKS.

THE EXPANSION OF GLASS AT HIGH TEMPERATURES.

BY W. B. PIETENPOL.

THE expansion of different kinds of glass has been determined by a direct microscope method. An electric furnace, one hundred cm. in length and six cm. in diameter, was constructed with small openings through which the

microscopes were focused upon the samples of glass. By the use of auxiliary heating coils in parallel with resistances the temperature was kept uniform. As measured by thermocouples in different parts of the furnace, the temperature varied by less than 1° C. during the observations.

The expansion of optical and other glass was measured from room temperature to 750° C. The rate of expansion of annealed glass is linear until temperatures of 450° to 550° C. depending upon the kind of glass. The rate of expansion then increases by 4 to 6 times through a temperature range of 60 to 100° C. This is in agreement with the expansion determined by C. G. Peters of the Bureau of Standards by the Fizeau method.

Measurements have been extended to higher temperatures. After the rapid increase in expansion the rate of expansion again becomes nearly linear, in general being slightly greater than at low temperatures.

With unannealed glass the rate of expansion in general decreases at a temperature of about 420° C. This decreased rate continues through a temperature range of 100° to 150°, when the rapid expansion takes place. In some instances the expansion through a range of 100° is practically zero. A second run upon the same piece of glass does not show this decrease in rate of expansion but a nearly linear rate until the point of rapid expansion is reached.

Certain glass after the rapid expansion has taken place at the usual temperature undergoes a rapid contraction. This takes place at about 620° C. and is a rate of contraction about 10 or 12 times the rate of expansion at low temperatures. This is explained as due to the release of a severe strain in the glass. The strip of glass when cooled is shorter by about 0.8 of one per cent. A second and third run upon the same piece of glass give expansion curves similar to those for annealed glass.

UNIVERSITY OF PITTSBURGH.

THE ENTROPY OF GASES AND THE PRINCIPLE OF SIMILITUDE.

BY RICHARD C. TOLMAN.

FOR a perfect monatomic gas, the entropy is given by the following exact equation

$$S = S_1 + 2.5R \ln T - R \ln p, \quad (1)$$

where S_1 is the entropy of the gas in question at unit pressure and unit temperature.

Since perfect monatomic gases can differ from each other only in molecular weight, S_1 can only be a function of the molecular weight m . The principle of similitude previously developed by the author permits a determination of the form of this function and leads to the equation

$$S = 1.5 R \ln m + 2.5 R \ln T - R \ln p + S_0, \quad (2)$$

where S_0 is the same for all monatomic gases. Since all gases become monatomic and perfect at low enough temperatures and pressures, this equation

can be used for determining the entropy of any gas when the necessary thermal data to go to higher temperatures and pressures are available.

Experimental data for helium, argon, hydrogen, mercury, cadmium, and zinc are shown to agree with the equation.

A MORE GENERAL FORM OF THE MAXWELL DISTRIBUTION LAW.

BY GILBERT N. LEWIS AND G. E. GIBSON.

THE newer work upon specific heats and its intimate relation to the mysterious *quantum*, have made it desirable to study the processes of exchange of thermal energy in the simplest possible systems. One of the results of such a study has been to obtain a theorem for the distribution of velocity in a system of any number of monatomic molecules, of which the total energy is constant. When the number of molecules approaches infinity this formula gives the familiar Maxwell distribution law,

$$dP = \pi^{-1/2} \sqrt{\frac{n}{2r^2}} e^{-\frac{n}{2r^2} \dot{x}^2} d\dot{x},$$

where dP is the probability that any molecule has a component of velocity lying between \dot{x} and $(\dot{x} + d\dot{x})$, n is the total number of degrees of freedom, and r is the speed which one molecule would have if it alone possessed the total energy.

Starting with the simplest case of one-dimensional molecules, and taking first a system of two such molecules with constant total energy, a simple geometrical construction in a rudimentary Liouville space shows that the probability that the first molecule have a velocity between \dot{x}_1 and $(\dot{x}_1 + d\dot{x}_1)$ is $d\dot{x}_1/\pi(r^2 - \dot{x}_1^2)^{1/2}$. For three such molecules this probability (which is also the chance that a single molecule with three degrees of freedom shall have a component of velocity in the range $d\dot{x}$) is equal to $\frac{1}{2}r d\dot{x}$, or $dP/d\dot{x}$, is constant.

Generalizing to a system of n degrees of freedom, we find that

$$dP = \frac{r}{\sqrt{(r^2 - \dot{x}_1^2)}} \frac{S_1}{S_2} d\dot{x}_1,$$

where S_1 is the surface of an $(n - 1)$ -dimensional sphere of radius $\sqrt{(r^2 - \dot{x}_1^2)}$, and S_2 is the surface of an n -dimensional sphere of radius r . Making use of the Dirichlet integrals,

$$dP = \pi^{-1/2} \frac{n-1}{nr} \frac{\Gamma\left(1 + \frac{n}{2}\right)}{\Gamma\left(1 + \frac{n-1}{2}\right)} \left(1 - \frac{\dot{x}_1^2}{r^2}\right)^{(n-3)/2} d\dot{x}_1,$$

which is the general equation for the distribution of velocities in a system of any number of monatomic molecules with a constant total energy.

When n approaches infinity, noting that

$$\left(1 - \frac{\dot{x}_1^2}{r^2}\right)^{(n-3)/2} = e^{-\frac{n\dot{x}_1^2}{2r^2}}$$

and evaluating the Γ functions by Stirling's theorem,

$$dP = \pi^{-1/2} \sqrt{\frac{n}{2r^2}} e^{-\frac{n}{2r^2} \dot{x}_1^2} d\dot{x}_1,$$

Since the chance that a given molecule (molecule 1) has a component of velocity in the range $d\dot{x}_1$ is equal to the chance that *any* molecule has a velocity component in the range $d\dot{x}$, this equation becomes identical with Maxwell's equation given above.

UNIVERSITY OF CALIFORNIA.

THE THIRD LAW OF THERMODYNAMICS.

BY GILBERT N. LEWIS AND G. E. GIBSON.

IN a recent paper ("The Entropy of the Elements and the Third Law of Thermodynamics," J. Am. Chem. Soc., 39, 2554, 1917) the authors made a careful study of all the available data which could serve as a test of the third law of thermodynamics, namely, the law that the entropy changes in chemical reactions approach zero as the absolute zero of temperature is approached. In conclusion it was stated: "We have obtained in nine cases direct tests of the third law of thermodynamics. The average discrepancy in these nine cases has proved to be 1.6 entropy units or less than 500 cal. We believe that these discrepancies lie within the limits of experimental error which might reasonably be assigned in the individual cases, and furthermore that the discrepancies are less in those cases where the experimental accuracy seems the greater. While we hope that in the near future more accurate data concerning heats of reaction may be available, in the meantime we may assert that the third law rests upon a more adequate experimental basis than either the first or second laws of thermodynamics possessed at the time of their universal adoption. We believe, therefore, that it would be an excess of conservatism to refuse the acceptance of this powerful weapon of calculation in energetics until additional data are made available."

The new experiments there suggested have now been carried far enough by Mr. R. H. Gerke to show that in several cases investigated the discrepancies have been reduced greatly. The third law may therefore be considered to rest on a thoroughly satisfactory experimental foundation.

Nevertheless *a priori* considerations, as well as some incomplete but yet significant experiments, show the necessity of stating the third law in such a way as to limit its scope more strictly than has previously been done. Planck has already proposed to exclude processes of solution from the operation of this law. The authors in supporting this view, adduce evidence to show that even in the case of pure liquids there are at least some cases in which the third law as previously stated cannot be valid. The law is therefore restated as follows: If the entropy of each element in some crystalline form be taken as zero at the absolute zero, the entropy of any pure crystal at the absolute zero is zero, and the entropy of any other substance is greater than zero.

UNIVERSITY OF CALIFORNIA.

VOLUME CHANGES ACCOMPANYING THE TRANSITION OF A DENTAL
AMALGAM NEAR 70° C.

BY ARTHUR W. GRAY.

AT the Pittsburgh meeting of the Physical Society in December, 1917, and also at the Milwaukee meeting of the American Institute of Mining Engineers in October, 1918, lantern-slides were shown to illustrate changes in strength, in specific heat, and in thermal expansivity that occur while a dental amalgam is heated through the transition region near 70° C. From a series of transition curves obtained during August and September, 1917, only those exhibited at these meetings have so far been published.¹

Some of the results found during this investigation of the critical region have recently been confirmed by data on the thermal expansivity of amalgams published by Souder and Peters of the Bureau of Standards in reporting tests of dental materials.²

The values that they give for the thermal expansivities of various amalgams between 20° and 50° C., the shapes of the expansion-temperature curves, and the observation that some of the samples after heating to about 80° C. became covered with drops that soon changed into bright crystals—all of these, as far as they go, agree with my own observations.

Other interesting phenomena connected with the transition are not mentioned by Souder and Peters.

Although the Bureau of Standards made experiments for the purpose of discovering effects of including zinc as one of the constituents of a dental alloy—a matter much debated in the dental literature but with no presentation of reliable experimental evidence to support the views either of those who advocate or of those who condemn the use of the metal—the published account of the tests made at the Bureau gives the impression that certain striking phenomena associated with the presence of zinc were not noticed.

Among such phenomena are those connected with the conditions that determine whether or not a specimen of amalgam becomes covered with droplets from which crystals develop. During the study referred to in the first paragraph of this abstract, and also during various crushing-strength tests, I noticed that thoroughly hardened amalgams from alloys containing a per cent. or so of zinc rapidly produced crystals when heated into the transition region, while similarly treated amalgams from non-zinc alloys did not. Droplets and crystals were, however, readily obtained with freshly made test cylinders prepared from both a zinc and a non-zinc alloy. These crystals are beautiful six-sided tablets, which apparently belong to either the hexagonal or the orthorhombic system.

¹ A. W. Gray, "Metallographic Phenomena Observed in Amalgams," *Am. Inst. Min. Eng., Supplement to Bull. No. 144, Dec., 1918; Trans., 60, 657-697. Journ. National Dental Association, 6, 513-531, 909-925, 1919.*

² W. H. Souder and C. G. Peters, "An Investigation of the Physical Properties of Dental Materials," *Dental Cosmos, 62, 305-335.*

The amalgams from the non-zinc alloys that I tested yielded expansion-temperature curves similar to those shown in Fig. 14 of my paper.¹ The typical curve is characterized by an almost straight portion that slopes upward until the transition begins, when a rapid drop to a sharp minimum occurs. This is followed by a slight but rapid rise, which, in turn, is succeeded by a further drop. The contraction accompanying the transition may reduce the diameter of the amalgam cylinder below the diameter it previously had at room temperature. Reheating an amalgam yielded a curve of the same general shape as that obtained during the first heating, but with the transition-region characteristics less pronounced. Also, in the case of certain non-zinc amalgams, especially those from alloys low in silver and high in copper, these characteristics, though noticeable, were not very prominent. These observations are confirmed by the expansion curves for alloys A, K, and L in Fig. 8 of the paper of Souder and Peters.²

Amalgams from zinc alloys were, on the other hand, usually found to yield expansion curves similar to those shown by Souder and Peters for alloy H (Fig. 7) and alloy B (Fig. 8). The outstanding characteristic of such a curve is a gradually increasing upward curvature that rapidly changes into a steep rise as the transformation gets under way. Once this rapid expansion is well started it will continue for some hours, although the temperature be held constant, or even lowered.

That zinc exerts very little influence upon the expansivity until the transition-region is approached is evident from both my own curves and those of Souder and Peters. That it is not the only factor determining the behavior during transition is indicated by Souder and Peters' curve for alloy P (Fig. 7), which begins transition with a contraction although it contains five per cent. of zinc. The fact that this particular alloy contains only sixty per cent. of silver may have some bearing. That zinc may, however, exert an enormous influence in the critical region is clearly seen upon comparing the expansion-temperature curve yielded by an amalgam cylinder from an alloy containing 70 silver, 27 tin, and 3 copper with the curve yielded by a cylinder prepared in exactly the same way from an alloy that differed from this only in that one per cent. of zinc was added.

PHYSICAL RESEARCH LABORATORY,
THE L. D. CAULK COMPANY,
MILFORD, DELAWARE,
April 7, 1920.

RESULTS OF ATMOSPHERIC-ELECTRIC OBSERVATIONS MADE DURING THE SOLAR
ECLIPSE OF MAY 29, 1919.

By S. J. MAUCHLY AND ANDREW THOMSON.

THE observations forming the basis of this paper were made at Sobral in northeastern Brazil in accordance with the general plan of the Depart-

¹ Am. Inst. Min. & Met. Eng. Trans., 60, p. 672; Journ. Nat. Dent. Assn., 6, p. 526.

² Dental Cosmos, p. 315.

ment of Terrestrial Magnetism for magnetic and electric observations during the solar eclipse of May 29, 1919.

Sobral, located in the belt of totality, is about 55 miles from the coast, longitude $40^{\circ} 20'.8$ W., latitude $3^{\circ} 41'.6$ S. The eclipse, at Sobral, began at $8^{\text{h}} 04^{\text{m}}$ (L.M.T.) and ended at $10^{\text{h}} 47^{\text{m}}$ (L.M.T.). The duration of totality was 5.3 minutes, mid-totality occurring at $9^{\text{h}} 19^{\text{m}}$ (L. M. T.).

The atmospheric-electric elements under observation consisted of positive conductivity, negative conductivity, and potential gradient. The apparatus and methods used were in general the same as those employed by the authors at Lakin, Kansas, during the solar eclipse of June 8, 1918,¹ except that the potential-gradient observations during the eclipse were made at intervals of one half minute, instead of two minutes as at Lakin, and that a special form of insulator was designed for supporting the ionium collectors used in the potential-gradient observations. This insulator was provided as a precaution against insulation troubles due to rain, extreme humidity, and the activities of small insects, and proved to be entirely satisfactory. The apparatus used for potential-gradient observations was standardized by the method of Simpson and Wright.²

The actual observations were made by Mr. Thomson, assisted by Mr. Antonio Lima. Regular observations were made hourly, for periods of about 20 minutes, throughout the forenoons from May 24 to June 2, inclusive, except on May 29, when the observations were made as nearly continuously as was consistent with adequate control observations.

The general results may be given as follows:

(a) The potential gradient showed a well-formed minimum beginning with totality and extending until about 20 minutes after totality. The values observed during this period were about 20 per cent. lower than the mean derived from two equal periods immediately preceding and following it.

(b) During the period of potential-gradient minimum the fluctuations of the gradient were very much smaller than during the similar periods preceding and following.

(c) The positive and negative conductivities (and, therefore, the total conductivity also) each showed an increase of the order of 20 per cent., beginning just after totality and continuing for about 15 minutes.

(d) The air-earth current-density computed from the potential gradient and total conductivity showed a greater constancy during the period in which the obscuration was at least 50 per cent. than was observed for any equal period throughout the forenoon of the eclipse day.

From the above it appears that the results for the Sobral station are in general agreement with those obtained at Lakin, during the eclipse of June 8, 1918 (l.c.), notwithstanding the great differences between the two stations as regards latitude, elevation, general topography, and distance from sea.

DEPARTMENT OF TERRESTRIAL MAGNETISM.

¹ Terr. Mag., Vol. 24, March and June, 1919.

² Proc. R. Soc. A., Vol. 85, p. 182, 1911.

EFFECTS OF DIFFERENTIAL REFRACTION IN THE EARTH'S ATMOSPHERE UPON
OBSERVED LIGHT DEFLECTIONS.

BY L. A. BAUER AND W. J. PETERS.

A NOTE concerning the above subject was presented by the first author before the American Physical Society at the meeting in New York on February 29, 1920. On the basis of the published deflections of light, resulting from the best of the photographic plates obtained by the British astronomical party at Sobral, Brazil, during the solar eclipse of May 29, 1919, it was found:

(a) That the value of the radial deflection at the sun's limb deduced from the stars near the sun's axis was 7 to 9 per cent. larger than the corresponding value deduced from the stars near the sun's equator.

(b) There were systematic non-radial effects, amounting at times to nearly one-tenth of the predicted Einstein radial deflection at the sun's limb, and 3 to 7 times the probable error.

(c) The superposed or additional effects referred to in (a) and (b) could be satisfactorily represented by trigonometric functions of the position angles of the stars, such as would arise, for example, if in addition to the mass-attraction effects of the sun, which alone are considered in the Einstein formula, it would also be possible to have effects from forces similar to centrifugal ones, or from such variations in gravity with heliographic latitude as would result if the sun approximated to an oblate spheroid.

Calculations readily showed, however, that the superposed effects are too large to be accounted for by centrifugal forces or variations in gravity with heliographic latitude, or with position angle of star. It was found that non-radial effects might also be the result of uneliminated differential refractions in the earth's atmosphere. Accordingly, the question of possible outstanding effects arising from incomplete elimination of differential refractions in the earth's atmosphere has been carefully investigated, with the following preliminary results:

(a) The non-radial portions of the observed light deflections may be largely, if not completely, accounted for by incomplete elimination of effects similar to differential refraction effects in the earth's atmosphere.

(b) The same cause which accounts for (a) may also possibly explain why the observed light deflections, on the average, exceeded by about 14 per cent. the amounts predicted on the basis of the Einstein law of gravitation.

NOTE ON ELECTROMAGNETIC INDUCTION AND RELATIVE MOTION.

BY S. J. BARNETT.

A LETTER received over a year ago from Professor Eddington, together with a note just published by Dr. W. F. G. Swann,¹ shows that my paper "On Electromagnetic Induction and Relative Motion, II.,"² read

¹ PHYS. REV., March, 1920, p. 227.

² PHYS. REV., August, 1918, p. 95.

before this society in December, 1917, has given the impression that I had not considered the alternative to the applicability of what might be called the "magnetic guard-ring" hypothesis on which the conclusions of the paper were frankly based.

This is not the case, but I have long been convinced that too little weight was given this alternative, viz., the strict applicability of the principle of superposition. Its apparent validity over a vast range including, for example, such different phenomena as those involved in the Cavendish experiment on the law of electric force and in the production of a magnetic field outside the plates of a condenser in motion with an electric field practically restricted to the region between the plates, makes the probability of its general validity very great.

When a single magnet, as the upper magnet in my experiment, moves past the screened condenser, with the lower magnet removed, the condenser does not become charged. In the original paper (pages 97, 113) and elsewhere, I have referred to this fact, which Dr. Swann appears to consider new. It is true on any theory, and was experimentally proved in the course of my work (p. 113), which involved many other matters of interest to me beside the main point at issue. The lower magnet itself produces no charge on the condenser. Hence, on the principle of superposition, when the lower magnet is present and the upper magnet moves (with magnetization stationary at the center of motion), the condenser remains uncharged.

The question was not whether an electric *intensity* is produced by a magnet or a magnetic field in translation, as Dr. Swann seems to imply. That is accepted by all theories, and I think that no proper interpretation of the experiment on either hypothesis could be considered evidence in denial of it. The question was whether, the existence of this intensity being granted, a *displacement* (and charge) resulted under certain conditions. The intensity and displacement in free æther are, of course, identical on the theories of Maxwell and Lorentz.

The experiment is briefly discussed from both standpoints in a section of a paper¹ which I read before the Cornell Conference in June and before this society and the Institute of Electrical Engineers on October 10, and which Dr. Swann evidently overlooked. His criticisms are essentially identical with those which I presented in this paper, printed by the Institute early in October.

AN INTEGRATION METHOD OF DERIVING ALTERNATING CURRENT RESISTANCE AND INDUCTANCE OF CONDUCTORS.

BY H. L. CURTIS.

IF small wires are placed side by side and if an alternating electromotive force is applied to their terminals, the current which flows in any one wire is determined by its resistance and inductance and by the mutual inductance

¹ Proc. A. I. E. E., Oct., 1919, p. 1151.

between it and each of the other wires. A long, uniform conductor may be considered as composed of an infinite number of filaments whose boundaries coincide with the lines of flow. Then the instantaneous current $\delta I_x'$ through the filament x is given by the equation

$$E' = r\delta I_x' + \iint M_{xy} \frac{d}{dt} \delta I_y',$$

where E' is the instantaneous value of the applied electromotive force, r resistance of the filament, M_{xy} the mutual inductance between the filament x and another y which carries a current $\delta I_y'$. The total instantaneous current through the conductor is given by the equation

$$I' = \iint \delta I_x'.$$

This method has been used to compute the alternating current resistance and inductance of a return circuit of straight, parallel, non-magnetic, cylindrical conductors. The resulting formulas are:

$$\begin{aligned} \frac{R}{R_0} &= \frac{A_0 - \lambda(A_0\alpha_1 - A_1\alpha_0)}{A_0^2 + \alpha_0^2} + \lambda^2 \left\{ \frac{a}{s} \right\}^2 \frac{B_1B_2 + \beta_1\beta_2}{B_2^2 + \beta_2^2} \\ &+ \frac{\lambda^2}{6} \left\{ \frac{a}{s} \right\}^4 \frac{\Gamma_1\Gamma_2 + \gamma_1\gamma_2}{\Gamma_2^2 + \gamma_2^2} \\ &+ \frac{\lambda^3}{3} \left\{ \frac{a}{s} \right\}^6 \frac{(B_2\gamma_2 + \beta_2\Gamma_2)(B_1\Gamma_1 - \beta_1\gamma_1) - (B_1\gamma_1 + \beta_1\Gamma_1)(B_2\Gamma_2 - \beta_2\gamma_2)}{(B_2\gamma_2 + \beta_2\Gamma_2)^2 + (B_2\Gamma_2 - \beta_2\gamma_2)^2} \\ &+ \frac{\lambda^2}{18} \left\{ \frac{a}{s} \right\}^6 \frac{\Delta_1\Delta_2 + \delta_1\delta_2}{\Delta_2^2 + \delta_2^2}, \\ L &= 2l \log \frac{s}{a} + l \frac{A_0A_1 + \alpha_0 \left\{ \alpha_1 - \frac{1}{\lambda} \right\}}{A_0^2 + \alpha_0^2} + l\lambda \left\{ \frac{a}{s} \right\}^2 \frac{\beta_1B_2 - B_1\beta_2}{B_2^2 + \beta_2^2} \\ &+ \frac{l\lambda}{6} \left\{ \frac{a}{s} \right\}^4 \frac{\gamma_1\Gamma_2 - \Gamma_1\gamma_2}{\Gamma_2^2 + \gamma_2^2} \\ &+ \frac{l\lambda^2}{3} \left\{ \frac{a}{s} \right\}^6 \frac{(B_1\Gamma_1 - \beta_1\gamma_1)(B_2\Gamma_2 - \beta_2\gamma_2) + (B_1\gamma_1 + \beta_1\Gamma_1)(B_2\gamma_2 + \beta_2\Gamma_2)}{(B_2\gamma_2 + \beta_2\Gamma_2)^2 + (B_2\Gamma_2 - \beta_2\gamma_2)^2} \\ &+ \frac{l\lambda}{18} \left\{ \frac{a}{s} \right\}^6 \frac{\delta_1\Delta_2 - \Delta_1\delta_2}{\Delta_2^2 + \delta_2^2}. \end{aligned}$$

In these formulas

- R = the resistance at a frequency n .
- L = the self-inductance at this frequency.
- R_0 = the direct current resistance.
- l = the length of the circuit (one-half the length of the wire).
- a = the radius of the wire.
- s = the distance between the centers of the wires.
- σ = the resistivity of the wire.

$$\lambda = \frac{2\pi^2 na^2}{\sigma}$$

$$A_0 = 1 - \frac{\lambda^2}{12} + \frac{\lambda^4}{2880} - \dots,$$

$$\alpha_0 = \frac{\lambda}{2} \left\{ 1 - \frac{\lambda^2}{72} + \frac{\lambda^4}{43200} - \dots \right\},$$

$$A_1 = 1 - \frac{\lambda^2}{36} + \frac{\lambda^4}{14400} - \dots,$$

$$\alpha_1 = \frac{\lambda}{4} \left\{ 1 - \frac{\lambda^2}{144} + \frac{\lambda^4}{129600} - \dots \right\},$$

$$B_1 = 1 - \frac{\lambda^2}{24} + \frac{\lambda^4}{8640} - \dots,$$

$$\beta_1 = \frac{\lambda}{3} \left\{ 1 - \frac{\lambda^2}{120} + \frac{\lambda^4}{100800} - \dots \right\},$$

$$\Gamma_1 = 1 - \frac{\lambda^2}{40} + \frac{\lambda^4}{20160} - \dots,$$

$$\lambda_1 = \frac{\lambda}{4} \left\{ 1 - \frac{\lambda^2}{180} + \frac{\lambda^4}{201600} - \dots \right\},$$

$$\Delta_1 = 1 - \frac{\lambda^2}{60} + \frac{\lambda^4}{40320} - \dots,$$

$$\delta_1 = \frac{\lambda}{5} \left\{ 1 - \frac{\lambda^2}{252} + \frac{\lambda^4}{362880} - \dots \right\},$$

$$B_2 = 1 - \lambda\alpha_1 + \frac{\lambda a^2}{2s^2} \beta_1 + \frac{\lambda^2 a^6}{6s^6} \frac{\Gamma_2(B_1\Gamma_1 - \beta_1\gamma_1) + \gamma_2(B_1\gamma_1 + \beta_1\Gamma_1)}{\Gamma_2^2 + \gamma_2^2},$$

$$\beta_2 = \lambda A_1 - \frac{\lambda}{2} \frac{a^2}{s^2} B_1 + \frac{\lambda^2 a^6}{6s^6} \frac{\Gamma_2(B_1\gamma_1 + \beta_1\Gamma_1) - \gamma_2(B_1\Gamma_1 - \beta_1\gamma_1)}{\Gamma_2^2 + \gamma_2^2},$$

$$\Gamma_2 = A_0 + \frac{\lambda a^4}{2s^4} \gamma_1,$$

$$\gamma_2 = \alpha_0 - \frac{\lambda a^4}{2s^4} \Gamma_1,$$

$$\Delta_2 = B_1 + \frac{5\lambda a^6}{6s^6} \delta_1,$$

$$\delta_2 = \beta_1 - \frac{5\lambda a^6}{6s^6} \Delta_1.$$

To test these formulas, the inductance and resistance of parallel wires at different spacings have been measured at a number of frequencies. The resistance increases very rapidly as the spacing is decreased, yet the difference between the measured and calculated values is in no case greater than 1 per cent. At any given spacing, the inductance decreases with increasing fre-

quency, and this decrease is greatest when the wires are very close together. Again, the measured and calculated values agree within experimental error.

BUREAU OF STANDARDS,
WASHINGTON, D. C.,
April 24, 1920.

THE STATUS OF OHM'S LAW.

BY F. WENNER.

JUST about 50 years ago an investigation of the accuracy of Ohm's law was made by a committee of the British Association. Maxwell was chairman of this committee and he devised two methods for making the test, both of which were capable of giving a really high precision. The precision claimed for the measurements in which these methods were used was 1 in 10^5 for the first and 1 in 10^{12} for the second, and no departure from the law was found. Because of the higher precision in the experiments in which the second method was used, almost no weight was given to the results obtained in the experiments in which the first method was used.

Since the report on this work, the law has generally been accepted to the same extent that the inverse square law is accepted for gravitational forces but it has not received a like amount of discussion. At this time when we are giving the most profound consideration to the fundamental laws of the physical sciences, it will not be out of place to call attention to the fact that if the current had been proportional to the square of the potential drop or been any other definite function of the potential drop, the same results would have been obtained, in the experiments in which the second method was used, as were obtained. The investigation does not, therefore, constitute a proof of the accuracy of the law in the sense in which the law is generally accepted. We are, therefore, justified in asking what is the basis for the law and to what extent is it probably true.

The law is not dependent upon any of the fundamental principles of the physical sciences and, to date, cannot be said to have any theoretical basis. From the theoretical standpoint, the law is considered as one of the experimentally determined facts to which theories of conduction must be made to conform. We, therefore, must, for the present at least, base our conclusions as to the extent to which the law is valid upon experiments bearing on the question.

Using the first method of Maxwell, which is correct in principle, Mr. Hanson and I, some years ago, obtained a precision of about 1 in 10^6 . Using a method devised by Dr. Wolff of this Bureau, but which has not been published, we obtained a precision of about 3 in 10^7 . With neither method was a departure in proportionality between the current and the potential drop caused by the current observed.

A number of other methods have been considered and one which later was found not to be correct in principle was tried. One of the methods devised,

which presumably is correct in principle but which has not been tried, is probably capable of yielding a precision of 1 in 10^8 . This is as high as at present there is any need to know the proportionality between current and resulting drop in potential.

BUREAU OF STANDARDS.

THE INDUCTANCE OF COILS WOUND ON POLYGONAL FORMS.

BY FREDERICK W. GROVER.

IT is becoming common practice to wind single layer coils on forms of such a nature that the helix obtained lies on the surface of a prism of polygonal section rather than on a cylinder, as is the case with the usual solenoidal coil. Such a winding has the advantage that the wire need touch the winding frame only at the vertices of the polygon, and thus the amount of insulating material in the electrical field may be reduced, with a diminution of the capacity of the coil.

Investigation of the case where the coil is wound on a prism of square cross section shows that the inductance is not very different from that of a circular solenoid whose cross section is equal in area to the area of the polygon. Only for extremely short coils is the radius of the solenoid of equal inductance appreciably greater than the radius of the circle whose area is equal to the area of the polygon, and even then the difference does not exceed a few per cent. It is, therefore, convenient to calculate the inductance of a polygonal coil from the well known formula for a circular-section solenoid, using in place of the mean radius the "equivalent" radius of the coil. The inductance thus obtained is that of a current sheet, and must be corrected to take into account the concentration of the current in the cross section of the wires rather than over the surface of the prism. To this end the same formulas are applicable as for the circular solenoid, if the equivalent radius be used.

The author has calculated tables of the equivalent radius for coils of triangular, square, hexagonal, and octagonal cross section, as well as for polygons of ten and twelve sides. The exact formula for the case of a square cross section has been obtained for all lengths of coil, by integration of the known formula for the mutual inductance of parallel squares. For the other cases it has been necessary to build up the formulas for the mutual inductance of polygons of the desired number of sides. Expanding this in a series, and substituting the appropriate geometric mean distances and arithmetic mean distances, the expression for the inductance of a short coil results, from which the "equivalent radius" of the coil may be derived by a few successive approximations. Formulas for long coils are not necessary, since the small deviations from the equal area assumption may be derived by interpolation between the known values for a square coil and the limiting case of an infinite number of sides.

The tables are capable of giving the inductance to one part in ten thousand. In addition to the formulas for mutual inductance which have been derived for the different polygons, self-inductance formulas have been found for polygons of round wire.

COLBY COLLEGE.

A MODIFICATION OF THE BRAUN ELECTROSTATIC VOLTMETER.

BY J. E. SHRADER.

THE ordinary type of Braun electrostatic voltmeter is more of an indicating instrument than it is one of precision. The Kelvin multicellular voltmeter is capable of more precision but is more subject to injury during use and has considerable capacity.

The Braun electrostatic voltmeter as modified by the author is free from the objections of the older type and is rugged and has small capacity.

The Braun voltmeter operates on the principle of electrostatic repulsion between a stationary vane and a pivoted movable vane. The deflection is read on an arbitrary scale, one end of the movable vane serving as the pointer. The controlling force opposing the electrostatic force is gravity. The sensi-

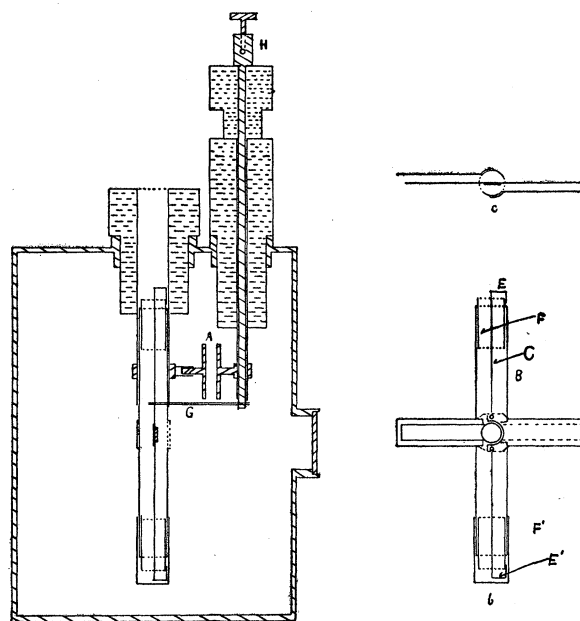

Fig. 1.

tivity is regulated by the weight of the moving vane as well as by the adjustment of its center of gravity. Because of the unavoidable friction of the bearing the lower range where the controlling force is small is very untrustworthy.

In the modified form the pivot is replaced by a phosphor bronze strip which is held under tension at each end. Two types of this modification have been made. In the first type the axis of rotation is horizontal and the controlling force is gravity modified slightly by the torsion of the phosphor bronze strip. In the second the axis of rotation is vertical and its controlling force is torsion practically unaffected by gravity.

This method of suspension eliminates friction and deflections are trustworthy enough to warrant their being read by the deflection of a spot of light from a mirror at the axis of the movable vane. By observing deflections for applied potentials the instrument may be calibrated for either D.C. or A.C. For A.C. the range may be extended by joining in series with the instrument a condenser of suitable capacity. For high voltages the instrument may be filled with an insulating oil which serves the double purpose of providing better insulation and damping the needle.

Fig. 1a is a diagram of an instrument of the oil-filled vertical type fitted with a condenser *A* which may be connected in series. This shows a side view of the moving part while *b* shows a front view and *c* is a cross section perpendicular to the axis. The part *b* consists of a brass tube *B* cut away on opposite sides at the middle to permit the rotation of the vane on an axis concentric with the tube. The suspension *C* is held under tension at the ends by springs

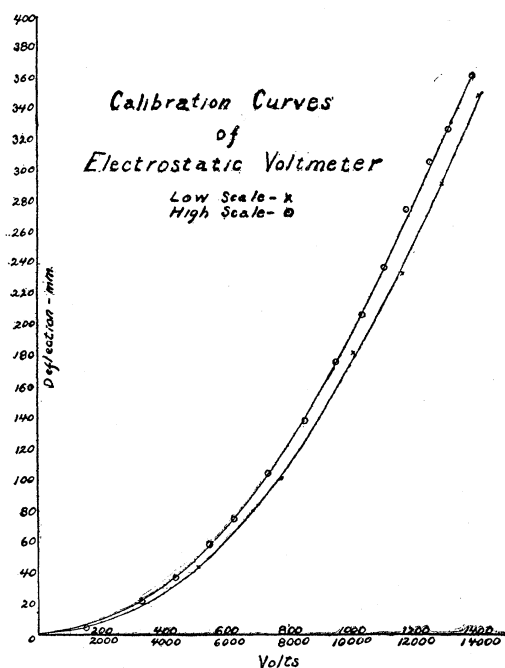

Fig. 2,

EE held by the thimbles *EF* in the end of the tube. The position of the stationary vanes is shown at *c*.

With a .025 inch phosphor bronze strip about $3\frac{1}{2}$ inches long a deflection of 40 cm. at a meter's distance has been obtained for 400 volts. For the particular problem in hand this sensitivity was too great. Consequently this suspension was replaced by a bifilar suspension of the same size strip. By

adjustment of the tension 40 cm. deflection corresponded to about 1,500 volts. The range of the instrument was then adjusted to ten times this value by varying the capacity of the series condenser. The condenser is shorted by the movable wire *G* connected to the insulated rod *H*.

The zero of the instruments of both types is very steady and the calibration is remarkably constant. The lower part of the range of the instrument as for all instruments of this type, is less sensitive but the instrument will indicate as accurately as the scale can be read which is not true for the older Braun type of instrument. Fig. 2 shows the calibration curves for the instrument both with and without the series condenser.

WESTINGHOUSE RESEARCH LABORATORIES.

ON THE USE OF CONTINUOUS WAVES FOR THE MEASUREMENT OF DIELECTRIC CONSTANTS OF LIQUIDS.

BY W. F. POWERS AND J. C. HUBBARD.

A RESONANCE method was developed by one of the writers¹ for measuring the dielectric constants of poorly conducting liquids. With improvements which have been made in the accuracy with which the resonance point may be determined it is now possible to determine the dielectric constant of poorly conducting liquids with an accuracy limited only by the accuracy with which the capacity of an air condenser may be calculated or calibrated.

An oscillating circuit consisting of a coil of a few turns of wire, of 10 to 15 cm. radius connected across the terminals of a variable air condenser is excited by suitably connecting with a three electrode vacuum tube and the necessary plate and filament batteries. At a distance great compared to the dimensions of the circuit is placed a receiving circuit consisting of a calibrated variable air condenser, the plates of which are connected to a coil of approximately the same constants as the coil of the generating circuit. Under these circumstances resonance is extremely sharp. The resonance point is detected by the use of a vacuum thermo-couple. The success of the present experiments is largely owing to the extremely high sensitivity of the vacuum thermo-couples supplied by the Western Electric Company. By reason of this high sensitivity it is only necessary to connect one point of the receiving circuit to one terminal of the heating element of the thermo-couple, a galvanometer being connected through a suitable resistance to the terminals of the thermo-element. The great advantage of this method of using a thermo-couple consists in the fact that the dissipation of energy in the receiving circuit is practically unaffected and there is no perceptible loss in the sharpness of resonance as is the case when the heater of the couple is in series in the receiving circuit.

For the measurement of dielectric constants a cell is provided containing a small condenser. This condenser consists of two circular plates of silver, 5 cm. in diameter and 0.5 cm. thick, held apart by three small discs of glass of known

¹ PHYSICAL REVIEW, Second Series, IX., p. 540, June, 1917.

thickness. Two sets of glass discs are provided giving a separation of the plates of d and d' , respectively. This condenser is connected in parallel with the variable air condenser of the receiving circuit. For the determination of a single value of the dielectric constant of a liquid at a given wave-length with errors due to lead wires eliminated, four readings of the variable condenser of the receiving circuit are necessary: viz., two resonance settings with air in the small standard condenser the plates of which are at d and d' respectively, and two resonance settings with the liquid under investigation in the small standard condenser the plates of which are at d and d' respectively. By the use of these four observations all effects are eliminated except that due to the change in capacity of the small condenser by varying its plate distance. The value of the dielectric constant thus deduced is free from lead wire corrections and boundary effects.

Various samples of water have been experimented upon by this method, including feebly conducting solutions up to a concentration of about one five hundredth normal. The dissipation increases so rapidly with concentration that it has thus far been impossible to get any definite knowledge of the dependence of dielectric constant upon strength of solution. The maximum reading of the galvanometer at resonance is, however, an extraordinarily sensitive index of the conductivity of various grades of distilled water.

For distilled water at 22° C. and at a wave-length of 200 meters the dielectric constant as determined by this method is 86.2.

Experiments are in progress upon the dependence of the dielectric constant of water upon the period of electrical oscillation. It is also hoped that progress will be made with the dielectric constants of salt solutions.

NEW YORK UNIVERSITY,
April, 1920.

AN EXTENSION OF THE RANGE OF THE McLEOD GAUGE.

BY A. H. PFUND.

THE limit of sensibility of a McLeod vacuum gauge is ordinarily considered as having been reached when the difference in level of the mercury columns is 1 millimeter. Under these conditions, however, the gas in the closed capillary is under the relatively large pressure of 1 mm. of Hg. It occurred to the writer that, by sealing a small loop of fine tungsten wire into the top of the closed capillary, advantage might be taken of the well-known properties of the hot-wire gauge to extend the range of the McLeod gauge. For preliminary trial, a rather insensitive McLeod gauge was constructed. While this gauge by itself failed to yield readings when the pressure dropped below 2.5×10^{-4} mm., the hot-wire gauge, used in conjunction with a portable galvanometer, allowed of the reading of pressures as low as 2.5×10^{-6} mm. By using a wall galvanometer pressures of the order of magnitude of 10^{-8} mm. and lower may be measured.

Various sources of error such as those due to character of the gas and heating

of the gas due to the hot wire are discussed. The performance of a vacuum thermo-couple (replacing the hot-wire) heated very slightly by external radiation, is finally considered. It is shown that, for a given gas, very reliable measurements may be carried out.

JOHNS HOPKINS UNIVERSITY,
April, 1920.

THE ELECTRIC SPARK—MODIFIED METHOD OF CONTROL.

BY W. O. SAWTELLE.

THE research is a continuation of the work on the control of an oscillatory spark discharge, by means of ultra-violet light, as reported on before the Society in 1911 and 1913, and published in the *Astrophysical Journal* for September, 1915. Previous work was carried on with a 20,000-volt storage battery as source of spark, while ultra-violet was supplied by a 500-volt D.C. arc light.

The battery is replaced by a modern static machine and the ultra-violet is supplied by an A.C. iron spark run by transformer on 110° A.C. lighting circuit. The arrangement of rotating mirrors remains the same.

When the light from the spark under investigation is in the right position to be reflected from the rotating mirror the ultra-violet from the iron spark plays upon the negative terminal of a second spark gap in series with the first, thus buffering the discharge at proper time. The images of resolved sparks are then allowed to fall on slit of prism spectroscope as before. It is intended to carry on spectroscopic work by means of this method.

Haverford College.

PIEZOELECTRIC AND ALLIED PHENOMENA IN ROCHELLE SALT.

BY JOSEPH VALASEK.

ANDERSON has found that the ballistic galvanometer charge and discharge throws are unequal for a condenser with Rochelle salt as dielectric. On the doublet theory of dielectric action the dielectric displacement D , electric intensity E , and polarization P (moment per unit volume) are analogous to B , H , and I in the case of magnetism. The alteration of the charge density on the plates of the condenser is moreover proportional to the dielectric displacement D . It appears then, that the asymmetry of the throws in Anderson's experiment is due to a hysteresis in P analogous to magnetic hysteresis. This would suggest a parallelism between the behavior of Rochelle salt as a dielectric and steel, for example, as a ferromagnetic substance. Bearing out this idea, typical hysteresis curves were obtained for Rochelle salt, analogous to the B , H curves of magnetism. An interesting feature of these curves is that the displacement of the center of the loop from the origin gives a means of obtaining the permanent polarization and hence the molecular magnetic moment of the crystal in its natural state.

The D , E curves besides being unsymmetrical, approach saturation as E

increases. Thus, if a curve of $\delta D/\delta E$ is plotted against E , the resulting curve will have a maximum corresponding to the point of most rapid increase of D with E . Since the D , E curves are unsymmetrical in such a way that the slope continually falls in one direction, the negative branch of this $\delta D/\delta E$ vs. E curve will gradually fall to zero without any maximum. To the extent, then, that we can consider mechanical force and applied electric field equivalent in producing a change in the piezoelectric moment, we may expect that the relation between piezoelectric response and E will be of the same nature as the relation between $\delta D/\delta E$ and E . Curves showing the effect of electric field on the piezoelectric response have been obtained for various values of applied force. They all show maxima in conformity with the above conclusions.

It has also been observed that the piezoelectric response goes through a hysteresis cycle for temperature changes, when measurements are made in an atmosphere with a constant absolute humidity. It is possible that this effect is due to a change in the moisture content of the crystal, since it has been observed that a crystal will change in weight by more than 5 per cent. in three or four days if kept in a moist or dry atmosphere.

UNIVERSITY OF MINNESOTA,

April 8, 1920.

THE APPLICATION OF ROTATORY DISPERSION TO COLORIMETRY,
PHOTOMETRY AND PYROMETRY.

BY IRWIN G. PRIEST.

FOR reasons which will appear more in detail in papers to be published elsewhere¹ the author believes that the methods of rotatory dispersion are of preeminent practical importance in colorimetry, heterochromatic photometry and chromatography generally. The generalized fundamental reasons for this importance are:

1. The data obtained are distinguished by their physical definiteness, reliability and unambiguous significance from which follow the certain reproducibility and universal validity of specifications in terms of such data.
2. From the point of view of experimental and observational technique, these methods are extremely simple, convenient and satisfactory.

The most general and important presentation of this subject hitherto is in the papers of Arons² to which reference should be made.

The rotatory dispersion methods of colorimetry have been studied and applied to various problems by the author at the Bureau of Standards during a period of about seven years. A number of brief papers, abstracts and statements dealing with specific applications in a detached way have been published.³

¹ Sci. Pap. Bur. Stands. and Journ. Optical Soc. of Am.

² Ann. der Phy. (4), 33, pp. 799-832, 1910; (4) 39, pp. 545-568, 1912.

³ "The Quartz Colorimeter and Its Applicability to the Color Grading of Cotton Seed Oil," Proc. Soc. Cotton Products Analysts, May, 1914. (There are a number of serious

However, the more general useful application of these methods to various problems is at present greatly impeded by the following circumstances:

1. Very few are thoroughly acquainted with the theory and the experimental technique involved.
2. There are no established conventions for the expression of results.
3. The expression of results is very inconvenient and laborious because of a lack of fundamental tables to facilitate computing.
4. Finally, for the above reasons, there is no present basis for the intelligible, concise presentation of results of tests and researches making use of these methods.

In order to provide a definite basis for further work involving the use of rotatory dispersion in colorimetry and related subjects, the author is preparing more extensive papers the purposes of which will be:

1. To outline and expound the general theory of the method and its applications.
2. To systematize and standardize the expression of results and provide reference tables and curves to facilitate computation.
3. To treat of the several applications in detail.

The purpose of the present note is to bring this matter to the attention of the Physical Society and to afford its members an opportunity to examine the apparatus recently installed and now in use at the Bureau of Standards. Laboratory demonstrations illustrating the use of rotatory dispersion in the following problems will be made during the meeting for those interested:

1. The color grading of light sources in terms of color temperature (*a*) by the comparison source method; (*b*) by the "leucoscope" method.
2. The production of artificial daylight and light having the spectral distribution of a perfect radiator at various high temperatures including temperatures above the range of operation of radiators (4000° K., 5000° K.).
3. The photometry of lights of different colors.
4. The color grading of transparent objects.
5. The color grading of opaque objects.
6. The determination of "normal gray light."
7. The determination of complementaries.

The method used in reducing the data to terms of spectral distribution will be explained and illustrated by the special tables and charts which have been prepared for this purpose.

BUREAU OF STANDARDS,
April 8, 1920.

misprints in this paper.) (See also Priest and Peters, Proc. Soc. Cotton Products Analysts, May, 1915.) "A Proposed Method for the Photometry of Lights of Different Colors," *PHYS. REV.* (2), 6, 64, 1915; (2), 9, 341, 1917; (2), 10, 208, 1917. Remarks on the Determination of "White Light" (in discussion), *Trans. I. E. S.*, 13, 75-77, 1918. "A Precision Method for Producing Artificial Daylight," *PHYS. REV.* (2), 11, 502, 1918. "A Method for the Color Grading of Red Flares," *PHYS. REV.* (2), 14, 264, 1919.

COLOR MATCH AND SPECTRAL DISTRIBUTION.

BY EDWARD P. HYDE AND W. E. FORSYTHE.

WHEN two different radiators, such as a tungsten and a carbon lamp, are color-matched, *i.e.*, adjusted so that the integral color is the same, there has been some question as to the extent to which they have the same distribution of energy in the visible spectrum. This was tested out by one of the writers some years ago for carbon, tungsten and tantalum for a single temperature in the neighborhood of about 2160° K., and evidence was found that when the radiation intensities were set relatively equal at the two ends of the visible spectrum there was a difference at the center of the spectrum of about one-half per cent. between tungsten and carbon, and about twice this difference between carbon and tantalum. If two radiators have the same spectral distribution when they are color-matched, they can be brought to the condition for color-matching by measurements on the relative intensities of two spectral regions in different parts of the spectrum. Using an optical pyrometer first with a red, then with a blue glass screen before the eyepiece, four different radiators—a black-body, tungsten, tantalum, and untreated carbon—were set at the same relative intensity in the red and blue parts of the spectrum for several different temperatures. Measurements were then made with the pyrometer using a green glass screen to see if the four radiators, when thus matched in the red and blue, were also matched in the green. It was found that if these four radiators were color-matched by determining the temperature for which the ratio of the red intensity to the blue intensity was the same, then the ratio of the red to the green was not what it should be if they had the same spectral distribution when they were thus color-matched. Taking the black body as the standard, the untreated carbon was found to be the same within experimental errors. The ratio of red to green for tungsten differed from that of a black body by about one-half per cent. for a temperature of about 1500° K. to about eight per cent. for a temperature of about 2900° K. For tantalum this difference was very nearly constant for a range in temperature from 1500° K. to 2700° K. and was equal to about six per cent.

NELA RESEARCH LABORATORY,
CLEVELAND, OHIO,
April 8, 1920.

THE GOLD-POINT PALLADIUM-POINT BRIGHTNESS RATIO.

BY EDWARD P. HYDE AND W. E. FORSYTHE.

IN a paper on "The Effective Wave-Length of Red Glasses," published in the *Astrophysical Journal* in November, 1915, appeared a note on some results on the gold-point palladium-point brightness ratio. These data were obtained by measurements with an ordinary disappearing-filament optical pyrometer with a red glass in the eyepiece.

Since that time additional data have been obtained by the same method.

In addition some data have been taken on this ratio by means of a spectral pyrometer. In the work on this ratio several different black-body furnaces have been used. The sample of gold or palladium that was melted inside the black-body furnace was mounted between platinum wires supported by two porcelain tubes in such a manner that the central part of the sample could not touch either of these two tubes. This mounting was necessary as it has been found that if a single tube is used, sometimes the metal will touch and cling to the end of the tube, so that the electric circuit through the two platinum wires and the sample used to give a signal, when the sample melted, would not be broken at the instant of melting and thus a high value would be obtained. In the table are given the results of measurements on the ratio.

Summary of Results of Measurements of the Gold-Point Palladium-Point Brightness Ratio.

Method.	Number of Separate Determinations.	Number of Melts.		λ .	Average of Ratio Found.	Results for the Palladium Point.
		Pd.	Au.			
Ordinary pyrometer.	10	45	45	0.6663	76.9	1828.6° K.
Spectral pyrometer.	3	13	12	0.6018	122.2	1828.3° K.

The values for the palladium point were calculated from the ratios found, from the value of 1336° K. for the gold point and from $c_2 = 14,350 \mu$ deg. The range of values for the ratio found by means of the ordinary optical pyrometer is from one per cent. above to the same amount below the mean value given in the above table. This range in the ratio corresponds to about 1/12 of one per cent. in the value for the melting point of palladium. Thus the range due to this error is about $\pm 1.5^\circ$ K. The range for the values using the spectral pyrometer was about the same, being, in this case, somewhat less than one per cent. As a result of this work the laboratories of the General Electric Company have decided, for the time being, to accept 1828° K. as the palladium point.

NELA RESEARCH LABORATORY,
CLEVELAND, OHIO,
April 8, 1920.

A NOTE ON THE "TEMPERATURE SHIFT IN NEAR INFRA-RED BANDS."

BY H. M. RANDALL, W. F. COLBY, R. F. PATON.

AT the Chicago meeting of this Society last November, a report was given of the work done by Imes on the near infra-red absorption of the halogen acids, HF, HCl, and HBr. The structure of these bands was clearly in accord with the Bjerrum postulate which accounts for absorption in this region by the mechanism of vibration within the molecule modified by a rotation of the molecule according to the Bohr-Sommerfeld theory of quantized stationary states. A second paper at the same meeting undertook to show that the complete band could be represented by a parabolic formula

which one could obtain by applying the above postulate to the familiar Bohr-Kossel molecular model typical of this group of gases. In fact, the constants of the theoretical parabola agreed surprisingly well with observed values in spite of the approximation used in its derivation.

These bands presented two intensity maxima which could be identified with the most probable rotational velocity of the molecule. In fact, from the Bjerrum point of view the intensity of absorption is directly related to the number of molecules possessing the necessary rotational energy, and if one plots with suitable coördinates, he has a definite representation of what must correspond in the quantum theory to the Maxwellian distribution of velocities. The question was raised at the Chicago meeting whether one might also observe a shift of intensity maximum with temperature, as one does with the Maxwell

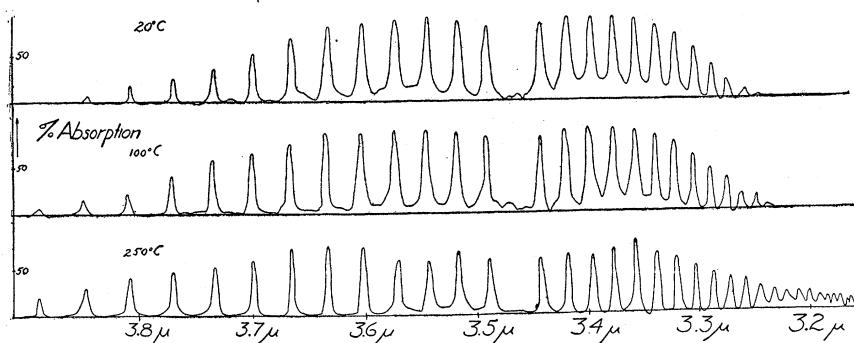

Fig. 1.

law. Work was even then far enough along to answer this in the affirmative, but the present paper is in a position to speak quite definitely.

The following curves give the absorption of HCl in the neighborhood of 3.4μ at the temperatures 20° , 105° , 250° . The curves are the result of an intermediate technique at the higher temperature. Quantitatively they will be replaced by work now in progress with larger masses of gas and more suitable arrangement for still higher temperatures. Some points are nevertheless unequivocal. In the first place, it is fairly certain that in spite of the outward shift of intensity to higher velocity values, that no shift takes place in the fine structure. Such a result would be an absolute demand of the theory of stationary states. If the angular momentum be multiples of a universal constant, we must expect that an increase of energy content merely shifts molecules from one state to another, the state itself being defined once for all. As to the form of the envelope of this curve and its deviation from Maxwell's law, we must await more exact quantitative measurements. It will be observed that the number of members has been increased from twelve at 20° to twenty-two at 250° even in this preliminary work. It is clear that the entire study of this subject will be aided by this possibility of shifting the intensity into regions otherwise inaccessible. For example, as a consequence of the theory presented

last November, one must expect a definite short wave-length limit to these bands, occurring for this curve at the thirty-eighth member. Higher members must return toward lower frequencies. If we might therefore see a curve including fifty members, it would consist apparently of two series converging to a common limit. Indications of such a return series is apparent in HCl at 1.7μ in spite of the general low intensity. Our theory predicts also that for HF the head should occur much earlier. Technical difficulties are there very great, and though the work is now under way, HCl may be more favorable to the investigation. Such a double-series theory may also aid in explaining the more complicated fine structure for triatomic gases like H_2O and CO_2 . A short wave-length limit strikingly suggests the head in visible band spectra. Heurlinger of Lund has recently undertaken an application of the Bjerrum postulate to band spectra. It is clear that the establishment of this common property would be of great mutual advantage to both regions. For this achievement we must look to these investigations at high temperature.

UNIVERSITY OF MICHIGAN.

TRANSMISSION BY THIN FILMS IN THE EXTREME ULTRA-VIOLET.

BY ELIZABETH R. LAIRD.

THROUGH the kindness of Professor Millikan the author had the opportunity of using the vacuum spectrograph used by him¹ and Dr. Sawyer in their work of extending the spectrum towards shorter wave-lengths, for testing the transparency of a few materials in the extreme ultra-violet. The carbon spark was used as source of light. As found by Professor Millikan and Dr. Sawyer the carbon spectrum goes to about 362 \AA ., not quite as far as that of iron or zinc, but the lines as a whole are brighter. In my use of the apparatus the lowest lines rarely showed, the plates not being as intense as the brightest of Dr. Sawyer's. It was not possible owing to the smallness of the source to take comparison spectra on the same plate, but a number of plates were taken under varied conditions to form an idea of the intensity to be obtained.

There were tried two samples of fluorite, silver foil in two thicknesses, and thin celluloid films. The first piece of fluorite 2.6 mm. thick, transmitted with very slight absorption to about 1240 \AA ., and then ceased abruptly to transmit at all. There was no evidence of a transmission band lower down. The second piece, somewhat thinner and very white and clear looking transmitted only to about 1550 \AA .. These results are in entire accord with those obtained earlier by Lyman. The silver foil, .00002 cm. thick transmitted the strong lines to 900 \AA . and two layers did the same, but the lines below 1140 \AA . were very faint. Celluloid films weighing .02 mg./cm². transmitted easily to 900 \AA . and faintly to 600 \AA . or lower. There was no direct indication of a lower limit of transmission, as the lines below 900 \AA . were not strong on the comparison plates and the lowest line obtained depended on the condition of spark and

¹ PHYS. REV., 12, p. 167, 1918.

grating. The interest in the celluloid transmission lies in the use of similar films as windows for the transmission of soft X rays.

MOUNT HOLYOKE COLLEGE.

THE LUMINESCENCE OF SAMARIUM.

BY HORACE L. HOWES.

THE luminescence spectra of several specimens of samarium oxide, mixed with calcium carbonate and heat-treated at various temperatures for different periods of time, have been studied. The excitation was by means of the cathode rays. Although the temperatures of the heat treatment ranged from 270° C. to the temperature of the positive electrode of the carbon arc, and the periods of time from one hour to three hours any change of the position of the bands was so small as to be within the errors of measurement. When the bands are plotted to a frequency scale the spectrum can easily be resolved into several short series of constant frequency interval.

NEW HAMPSHIRE COLLEGE.

THE EXISTENCE OF HOMOGENEOUS GROUPS OF LARGE IONS.

BY OSWALD BLACKWOOD.

THE author has attempted to devise experiments to determine whether the large ions produced by spraying water exist in a multitude of different sizes, or whether—as found by certain observers—only a few different sizes are present. His mobility apparatus has a “resolving power” twenty times greater than theirs, yet the mobility curves show no evidence whatever of grouping. The curves do indicate that the distribution of mobilities is continuous over a wide range.

RYERSON LABORATORY,
THE UNIVERSITY OF CHICAGO.

THE RESISTANCE OF A GAS TO THE MOTION OF A SPHERE WHEN THE MEAN FREE PATH IS LARGE IN COMPARISON WITH THE DIAMETER OF THE SPHERE.

BY R. A. MILLIKAN.

BY the use of the apparatus used by the author for the determination of “ e ,” the law of motion of a spherical particle through air has been very fully studied, down to pressures so low that the mean free path of the gas molecule is very large in comparison with the diameter of the sphere, and an empirical equation has been obtained which reproduces the results with much exactness. The equation differs considerably from the simple one deduced by Cunningham, and is also somewhat at variance with the experimental equation which represents the work of Knudsen. It has been derived, however, under conditions which are believed to be exceedingly trustworthy. It differs but slightly from

the equation published by the author from experiments made in 1912, but it represents much more exact work than that done at that time. The final form of the equation is as follows:

$$v = \frac{2}{9} \frac{ga^2}{\eta} (\sigma - \rho) \left(1 + A' \frac{l}{a} \right),$$

where $A' = 0.864 + 0.29 e^{-1.25(a/l)}$.

UNIVERSITY OF CHICAGO.

LOW VOLTAGE ARC IN HELIUM.

By K. T. COMPTON, P. S. OLMSTEAD AND ED. LILLY.

SINCE it has been proven that helium possesses a minimum radiating potential (20 volts) below its minimum ionizing potential (25.5 volts), and since electron impacts below 20 volts are elastic, we should expect the helium arc to strike at voltages as low as 20 volts by analogy with the arcs in metallic vapors studied by McLennan and Hebb. This could be explained by ionization due to successive impacts or to impacts against atoms which are in a less stable state than usual owing to the absorption of 20 volt resonance radiation. The latter of these two effects is shown by experiments to be of greater probable importance.

Using thermionic discharges from tungsten wires of several sizes up to 20 mil, in pure helium at pressures up to 25 mm., arcs could be made to strike at voltages as low as 20 volts with intense discharges and relatively high gas pressures. The arc never struck below 20 volts, though it could be maintained, having once struck, at voltages as low as 8 volts. This probably indicates that in the arc a large portion of the helium atoms contain electrons which are displaced to positions of higher potential energy than those in the normal atoms.

The low voltage arc spectrum was carefully studied under various conditions of excitation.

PRINCETON UNIVERSITY.

THE CRYSTAL STRUCTURE OF CARBORUNDUM.

By ALBERT W. HULL.

IN the Journal of the American Chemical Society for December, 1918,¹ Burdick and Owen have given an excellent determination of the crystal structure of carborundum by the Bragg method. They concluded that the arrangement of atoms was identical, except for slight distortion, with that of diamond, half of the carbon atoms of diamond being replaced by silicon atoms. On reviewing their data, the author was able to show² that the assumption of distortion was unnecessary and that the measurements of Burdick and Owen were consistent with a perfect diamond lattice.

Subsequently an X-ray powder photograph of carborundum was taken in

¹ Jour. of American Chemical Society, 40, 1749, 1918.

² PHYSICAL REVIEW, 13, 292, 1919.

the manner previously described,¹ and showed all the lines of a perfect diamond type of lattice, *plus a large number of additional lines*. An analysis of these additional lines has proved that they represent a complete hexagonal close-packed lattice. Many different samples of carborundum, ranging from sand to perfect transparent crystals, showed identical patterns. The lattice must consist, therefore, of a mixture *in the same crystal* of hexagonal and cubic close-packing of silicon atoms, with carbon atoms placed at the centers of the tetrahedra formed by the silicon atoms. This phenomenon of the mixture of cubic and hexagonal close-packing has been met with in several cases, notably in the case of cobalt,² and is exactly what is to be expected if the crystal grows rapidly in the direction of a hexagonal axis by the addition of planes normal to this axis. As each successive plane is added, it is a matter of pure chance whether its atoms find their place directly above those of the second plane beneath or the third plane beneath. The first alternative would give hexagonal close-packing, the second cubic close-packing. Annealing allows the weak forces between atoms to produce rearrangements, and in all cases observed has resulted in a perfect lattice of either the hexagonal or the cubic type. It is to be expected that the same would be true of carborundum if it could be annealed.

The complete data and more detailed discussion will be published elsewhere in the *PHYSICAL REVIEW*.

GENERAL ELECTRIC RESEARCH LABORATORIES.

ON THE ABSORPTION OF X-RAYS BY CHEMICAL ELEMENTS OF HIGH ATOMIC NUMBERS.

BY WILLIAM DUANE AND R. A. PATTERSON.

AT its recent New York meeting the authors presented to this Society a report on measurements of wave-lengths in the X-ray spectrum of tungsten, and a discussion of the bearing of the data on certain laws and theoretical deductions. In the research now reported we have extended the measurements of critical absorption wave-lengths to chemical elements of higher atomic numbers, including uranium and thorium.

A test of the general law that an emission frequency equals the difference between two absorption frequencies has been made by using the critical absorption wave-lengths in the M series of uranium and thorium measured by Stenström, and the emission wave-lengths in the L series measured by Siegbahn and Friman. Certain of the emission frequencies agree with the law to within the errors of measurement, but lines corresponding to all the possible differences between the absorption frequencies have not been observed.

A. Sommerfeld has derived a formula for certain frequency-differences which occur in the L group of X-ray spectra. This formula has been deduced from Bohr's theory on the assumption that the L orbit is a circle in some atoms of

¹ *PHYSICAL REVIEW*, 10, 666, 1917.

² Proceedings of the Institute of Electrical Engineers, Oct. 10, 1919.

a chemical element and an ellipse in other atoms of the same element. The relativity correction to the electron's mass gives a difference between the energy in a circular and that in an elliptic orbit. Corresponding to this difference in energy there is a difference in the vibration-frequencies associated with these orbits.

Sommerfeld's formula contains an undetermined constant. It is possible to find a value for this constant such that the formula gives the differences between our new experimental values to within the errors of measurement and calculation.

In the deduction of the formula it is assumed that the constant has the same value for circular as for elliptic orbits. As the constant represents the repulsive forces of neighboring electrons on each other, it is difficult to understand how this assumption can be true. Sommerfeld, himself, admits the difficulty of giving a satisfactory physical interpretation to this constant.

HARVARD UNIVERSITY.

THE MASS-ABSORPTION COEFFICIENT OF WATER, ALUMINIUM, COPPER, AND MOLYBDENUM FOR X-RAYS OF SHORT WAVE-LENGTH.

BY F. K. RICHTMYER AND KERR GRANT.

HULL and Rice¹ have measured the mass absorption coefficient of aluminium, copper and lead and find that μ/ρ is a linear function of the cube of the wave-length over the range of wave-lengths investigated. In the case of aluminium the measurements extended from $\lambda = 0.147 \text{ \AA.}$ to $\lambda = 0.392 \text{ \AA.}$; and over this range no discontinuity in the $(\mu/\rho) - \lambda$ curve was observed. In the case of lead a discontinuity was observed at 0.149 \AA. at the point corresponding to the short wave-length limit of the K. series for lead.

Barkla and White,² however, measuring μ/ρ of aluminium over the range $\lambda = .145 \text{ \AA.}$ to $\lambda = .509 \text{ \AA.}$ conclude that there is a discontinuity at $\lambda = .37 \text{ \AA.}$; the value of μ/ρ dropping several per cent. with increasing wave-length. A similar discontinuity was observed in carbon at $\lambda = .42 \text{ \AA.}$ and in oxygen (*i.e.*, water) at $\lambda = .39 \text{ \AA.}$ Since it is well known that, as one goes toward longer wave-lengths there is an abrupt drop in the value of μ/ρ at the short wave-length limit of the K and the L series, Barkla and White assumed that the discontinuities which they observed pointed to a new and shorter series of lines which they called the "J" series. Thus for Al the short wave-length limit of the "J" series would be at $\lambda = .37 \text{ \AA.}$

Duane and Shimizu³ tested this point directly by measuring the characteristic radiation from an Al target. After eliminating an apparent discontinuity at $\lambda = .3737 \text{ \AA.}$ in the "white" X-ray spectrum due really to the characteristic absorption of iodine in the ionization chamber, they conclude that "aluminium has no characteristic lines in its emission spectrum between the wave-lengths

¹ PHYSICAL REVIEW, Vol. VIII (N.S.), p. 326 (Sept., 1916).

² Phil. Mag. Vol., 34, p. 270 (October, 1917).

³ PHYSICAL REVIEW, Vol. 13, p. 288 (April, 1919), and Vol. 14, p. 389 (Nov., 1919).

$\lambda = .1820 \text{ \AA.}$ and 1.259 \AA. that amount to as much as 2 per cent. of the general radiation in the neighborhood."

While this disposes of any direct evidence of the existence of a "J" radiation, at least in aluminium, it leaves the discontinuities in μ/ρ observed by Barkla and White still unexplained. It seemed desirable, therefore, to make a careful study of the absorption of several substances over this range of wave-lengths.

The spectrometer used was of the Bragg type, excepting that the electro-scope was mounted on the ionization chamber. The tungsten target was approximately 50 cm. from the NaCl crystal. The "target" slit and the "chamber" slit were each one millimeter wide and were 30 cm. from the crystal. Methyl bromide was used in the ionization chamber. The absorber was placed in front of the "target" slit.

Ionization currents were measured by the "rate of deflection" method. In order to minimize secondary errors and to make the values of μ/ρ relative to each and as accurate as possible (1) the thickness of the absorber was, for each reading, so chosen that the transmitted beam was approximately 50 per cent. of the incident beam, and (2) the energy supplied to the X-ray tube was so adjusted as to make the incident energies the same in each case. The values of μ/ρ , relative to each other for any one substance, are correct to one per cent. Uncertainties as to absolute density and thickness of the absorbing material may make errors from one substance to another of 2 per cent.

The results may be summarized as follows:

1. From the shortest wave-length (.08 \AA.) investigated up to approximately 48. \AA. , discontinuities, *if they exist*, are certainly less than one per cent., a curve plotted between μ/ρ and λ being a perfectly smooth curve with no single point more than one per cent. from the graph. There seems to be, therefore, no evidence of a "J" series of lines within this region. It is suggested that the apparent discontinuities observed by Barkla and White may really have been due to a combination of a rather large experimental error with such an accidental grouping of the observations as would suggest a discontinuity.

2. For all the substances except water a curve plotted between μ/ρ and λ^3 is very nearly, *but not quite*, a straight line. The curve being very slightly concave toward the λ^3 axis. Thus for Al the equation

$$\left(\frac{\mu}{\rho}\right) = 14.45\lambda^3 + .15$$

represents, within 1 per cent., the absorption up to $\lambda = .4 \text{ \AA.}$ Above this value of λ the value of μ/ρ falls off slightly. For Cu the corresponding equation is

$$\left(\frac{\mu}{\rho}\right) = 162\lambda^3 + .16$$

within 1 per cent. up to $\lambda = .3 \text{ \AA.}$ Above this point the deviation from linearity is somewhat greater for Cu than for Al. These two equations combine

to give

$$\frac{\mu}{\rho} = .00658 \cdot N^3 \lambda^3 + .155,$$

where N is the atomic number.

3. For water (*i.e.*, practically oxygen) the curve plotted between μ/ρ and λ^3 is not even approximately a straight line, but is very decidedly concave toward the λ^3 axis. The curve, however, seems to extrapolate to a value of $\mu/\rho = .155$ for $\lambda = 0$. There is no tendency for a downward bend toward the value of $\mu/\rho = .04$ as found for the Gamma rays from Radium C. This seems to indicate that the absorption (scattering) of Gamma rays from Radium C is due to a process entirely different from the absorption of X-rays down to .08 Å.

Work is in progress to extend these data to longer wave-lengths and to substances of higher atomic number.

RESEARCH LABORATORY OF THE GENERAL ELECTRIC CO.,¹
SCHENECTADY, N. Y.

ON THE PHOTOELECTRIC LONG WAVE-LENGTH LIMIT OF PLATINUM AND SILVER.

BY OTTO STUHLMAN, JR.

IN a previous article it was shown that the photoelectric current coming from a transparent metallic wedge, when the metal side is turned away from the light, was a function of the thickness exposed and of the wave-length of the incident light energy. The curves for the metals examined have this in common; all make finite angles with the abscissa. The tangent to the curves at the origin are more inclined to the abscissa than the tangent at any other point. So that the photoelectric current occurring there, for any frequency of the incident light, bears a definite ratio to the mass per square centimeter of the film. The slopes at the origin are a measure of the photoelectric current given off by a metallic thickness comparable to the diameter of one molecule. Hence plotting these slopes as a function of the wave-length should give a curve which plunges into the axis of wave-lengths at a point where photoelectric action ceases.

The curves thus obtained are however unsatisfactory, for the intercepts on the wave-length axis are difficult to determine due to the relatively small angle at which they cut this axis. In order to obtain a more accurate method of finding this intercept, the logarithms of the photoelectric currents were plotted as a function of the wave-lengths. Under these circumstances the results develop curves which are concave downward and plunge into the abscissa at angles approaching ninety degrees. To justify this method of procedure similar data on the long wave-length limit, obtained from the results Werner, Pohl and Pringsheim, Millikan and Compton and Richardson, were subjected

¹ The work herein described was done at the laboratory of the General Electric Company while on leave of absence from our respective universities. It is indeed a pleasure to acknowledge our indebtedness to the laboratory staff for the many courtesies which have been shown us, and for the apparatus placed at our disposal. F. K. R. and K. G.

to this test, with results which justify the claim for the superiority of this method of approach.

The photoelectric long wave-length limit for the above two metals thus determined were: Platinum, $\lambda_0 = 284 \mu\mu$; silver, $\lambda_0 = 325 \mu\mu$.

WEST VIRGINIA UNIVERSITY,
MORGANTOWN, W. VA.

PHOTOELECTRIC EFFECT OF ALKALI-VAPORS AND A NEW DETERMINATION OF h .

BY E. H. WILLIAMS AND JAKOB KUNZ.

THE resonance potential of caesium vapor has been shown to be 1.48 volts while the ionization potential is 3.9 volts. If the same amount of work is required for the breaking up of a neutral caesium atom by light as by moving electrons, then the long wave-length limit of the photoelectric effect of caesium vapor should be $l = 318.4 \mu\mu$ according to the equation $hn = eV$. If this is found to be the case, then 2 facts of importance are established, first that the long wave-length limit is quite different for caesium vapor and for caesium metal and second, a new photoelectric method for the determination of h is available. Theoretically the experiment only requires to let monochromatic light of variable wave-length pass through a tube containing alkali vapors at a sufficient pressure and to note the wave-length, for which the photoelectric effect begins. Special care has to be taken to avoid scattering of light, photoelectric effect of the alkali metal deposited on the electrodes, ionization by collision and conduction over the glass walls. It has been found that there is no effect in caesium vapor down to $313 \mu\mu$, but that the effect at $253 \mu\mu$ is very marked. The measurements are being continued.

UNIVERSITY OF ILLINOIS,
URBANA, ILLINOIS,
April 8, 1920.

COLOR SENSITIVENESS OF PHOTOELECTRIC CELLS.

BY MISS E. FRANCES SEILER.

PHOTOELECTRIC cells containing the alkali-metals and argon at a low pressure were subjected to monochromatic light of variable wave-length and the photoelectric current was measured by means of a sensitive galvanometer. The curves obtained show a distinct maximum and resemble resonance curves. The maximum deflection was found as follows:

Li.....1 = 405 $\mu\mu$.	Rb.....1 = 473 $\mu\mu$.
Na.....1 = 420	Cs.....1 = 539.
K.....1 = 441	

In every case when the alkali-metals were sensitized by means of hydrogen, the maximum of the sensitiveness shifted toward longer wave-lengths.

UNIVERSITY OF ILLINOIS,
URBANA, ILLINOIS,
April 8, 1920.

MEASUREMENT OF SHORT TIME INTERVALS IN THE CORONA DISCHARGE.

BY CHARLES ST. FAZEL.

IT has been shown by E. Warner that the development of the characteristic pressure in the corona requires about 3 seconds if the measuring instrument is a Bristol ancoird pressure gage, while it takes about 15 seconds when the pressure increase is due to heat. In the present investigation a fine membrane and an oscillograph have at first been used for the measurement of time which elapses between the beginning of the corona current and the corona pressure. The time interval was found to be of the order of $\frac{1}{3}$ of a second. A manometric flame has also been used and the pulsations in the pressure of the corona tube when excited by alternating current of 60 cycles per second have been made visible by a rotating mirror.

Moreover it has been found that the pressure increase changes along the radius from the wire to the tube.

UNIVERSITY OF ILLINOIS,
URBANA, ILLINOIS,
April 8, 1920.

THE DETECTING EFFICIENCY OF THE ELECTRON TUBE AMPLIFIER.

BY E. O. HULBURT AND G. BREIT.

Problem and Method.—It is shown that the general problem of investigating the behavior of an amplifier requires the consideration of two interrelated problems, the first being the determination of the action of the amplifier itself, and the second the determination of the effect of the reaction between the amplifier and the external input circuit. The first problem is termed the *problem of detecting efficiency*, the second the *problem of input impedance*. The present paper deals with the problem of the detecting efficiency. The detecting efficiency of an amplifier depends on the relation between the input grid voltage change and the resulting change in the rectified component of the output plate current. Apparatus was arranged to produce and measure these quantities. The amplifier chosen for study was a three-tube high-frequency transformer-coupled amplifier. By means of a *condenser potential-divider* devised especially for the purpose, alternating voltage of small known value was impressed on the grid of the amplifier. The change in the rectified component of the plate current of the last tube was measured by a sensitive quadrant electrometer connected across a high resistance inserted in the plate circuit.

Experimental Results.—The electrometer deflections were proportional to the change in the rectified component of the output plate current b_0 , were recorded for a series of values of the input grid voltage A for various frequencies. It was found that b_0 is nearly proportional to A^2 . The detecting efficiency for a specified wave-length was defined to be

$$\lim_{A \rightarrow 0} \frac{b_0}{A^2}.$$

The detecting efficiencies were computed for various wave-lengths and plotted in a curve against wave-length. It is pointed out that this curve gives a complete solution of the problem of the detecting efficiency for this amplifier.

The amplification due to each tube of the above amplifier was measured. It was found that the sound intensity in the telephones was increased in the ratio of $9 \times 10^3 : 1$ owing to the use of the first three tubes.

JOHNS HOPKINS UNIVERSITY,
March, 1920.

THE DETECTING EFFICIENCY OF THE SINGLE ELECTRON TUBE.

BY E. O. HULBURT AND G. BREIT.

Problem.—In a previous communication entitled "The Detecting Efficiency of the Electron Tube Amplifier," the detecting efficiency for a specified frequency of a high frequency transformer-coupled amplifier has been defined by the relation $\lim_{A \rightarrow 0} \frac{b_0}{A^2}$ where b_0 is the amplitude of the rectified component of the output plate circuit and A the amplitude of the input grid potential. The detecting efficiency was determined for that amplifier by measuring A and b_0 directly.

In the present paper the detecting efficiency of a single electron tube is investigated both by theory and experiment.

Theoretical.—From a theoretical analysis in which the tube is a circuit element, an expression is derived for the detecting efficiency in terms of the tube and circuit constants. If the grid potential E_g is given by $A \cos \omega t$, then it is found that

$$\text{detecting efficiency} = \lim_{A \rightarrow 0} \frac{b_0}{A^2} = \frac{r_p^2 \frac{\partial^2 I_p}{\partial E_g^2}}{4 \left(1 + \frac{R_0}{r_p} \right) [(R_p + r_p)^2 + X_p^2]},$$

where I_p is the plate current,

R_0 is the direct current resistance of the plate circuit,

R_p is the resistance of the plate circuit at frequency $\omega/2\pi$,

X_p is the reactance of the plate circuit at frequency $\omega/2\pi$,

r_p is the internal resistance of the tube,

and where the derivative $\partial^2 I_p / \partial E_g^2$ is taken with the assumption that E_p (plate potential) is kept constant and is to be evaluated for the values of E_p and E_g when $A = 0$.

The assumptions used in the derivation of this formula were: (1) $E_g < 0$, (2) the function $I_p(E_p, E_g)$ can be expanded by Taylor's Theorem, (3) the amplitude A is sufficiently small to make terms in A^3 negligible, (4) the internal capacities of the tube are negligible, (5) the electron tube follows Van der Bijl's relation.

A more general formula for the detecting efficiency is derived where (5) is not assumed.

Experimental.—The method of producing and measuring A and b_0 was the same as that described in the former paper referred to above.

Results.—The formula for the detecting efficiency was tested by making R_p very high. This was done by inserting in the plate circuit an inductance shunted by a variable condenser. The values of the detecting efficiency, computed from A and b measured directly, were compared to the values given by the formula. Qualitative agreement was found. It was then shown by experimental test that exact agreement could not be obtained unless the internal capacities of the tube were taken into account. The results explain effects frequently observed in radio practice when Armstrong's tuned plate circuit is employed.

JOHNS HOPKINS UNIVERSITY,
March, 1920.

THE CALCULATION OF DETECTING AND AMPLIFYING PROPERTIES OF AN ELECTRON TUBE FROM ITS STATIC CHARACTERISTICS.

BY G. BREIT.

SOME calculations of amplifying and detecting properties of tubes have been previously made by Carson (Proc. Inst. of Radio Engineers, April, p. 187, 1919). Carson's treatment applies to tubes obeying Van der Bijl's relation and neglects the internal capacities of the tube. This is a more general treatment applying to any tube used with positive as well as with negative grid voltages. The fundamental assumptions are that the plate and grid currents can be expanded as Taylor's series of the grid and plate voltage. An expression is derived which enables one to calculate the strength of the signal received by means of an electron tube. Also a formula is derived for the input impedance of an electron tube used with positive grid voltage. The usual expression for the input impedance for the case of negative grid voltage is simplified by the introduction of a new quantity called the *intrinsic input impedance*. Calculations are made of the amplifying properties of tubes. The ideas of internal resistance and amplification constant are extended to the case when the capacities of the tube are not negligible by introducing: "the complex internal resistance" and "the complex amplification constant." The results are applied to explain the experiments by E. O. Hulburt and G. Breit on electron tubes.

THE JOHNS HOPKINS UNIVERSITY,
March, 1920.

THE EMISSION OF ELECTRONS FROM OXIDE-COATED FILAMENTS.

BY C. DAVISSON AND H. A. PIDGEON.

A TUNGSTEN or other metallic filament coated with only a very minute quantity of barium oxide exhibits, when heated, thermionic activity comparable with that of an oxide filament (Wehnelt cathode) coated in the usual way, that is, with from one to two milligrams of oxide per cm.²

Results of this nature are shown in Fig. 1. The straight line *aa* shows the relation between power supplied to a clean tungsten filament and the emission from it. After glowing a barium oxide coated filament mounted in the same exhausted tube near the tungsten filament for one hour at 1100° C., sufficient oxide had been transferred to change the power-emission line from *aa* to *bb*. For the power range *bb* the emission had been increased by a factor 10^9 . Increasing the power (temperature) beyond the range *bb* the emission decreases rapidly with time, and is finally again represented by points on *aa*.

Maintaining the "secondary" filament at a constant temperature in the

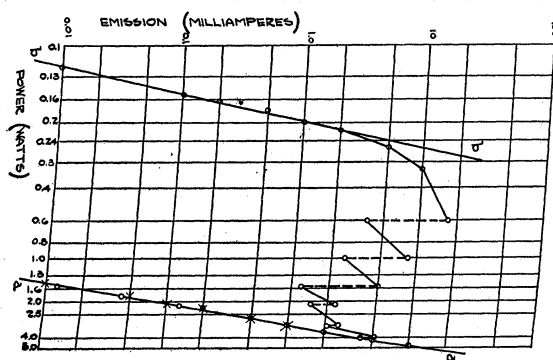

Fig. 1.

range *bb* (about 800° C.), the emission as a function of the density of deposit is shown by the points plotted in Fig. 2. The abscissæ are proportional to the number of equal increments of oxide transferred to the secondary and the ordinate to the resulting emission. Great care has been taken in obtaining data for this and similar curves to insure a uniform deposit of material on a flat uniformly heated area of the secondary filament. The relation between emission and density of deposit is represented with great accuracy to beyond the principal maximum by the sum of two terms of the form $Cx^n e^{-ax}$ where x represents the number of increments of deposit, and C , n and a are constants. The solid curve in Fig. 2 is the graph of the analytical expression of this form appearing in the figure. Such a relation between emission and quantity is to be expected if electrons are emitted not through the agency of discrete oxide molecules on the surface of the secondary, but only through the agency of definite aggregates of molecules. n , on this hypothesis, is a measure of the number of molecules constituting an aggregate, and a measures the product Ns , where N is the number of molecules delivered to the secondary per cm^2 per flash, or increment, and s is the largest area (cm^2) over which the n molecules may be disposed and still form an aggregate. It is necessary to suppose that emission occurs only when exactly n molecules occupy the area s .

For the secondary at sufficiently low constant temperature the emission is a function of the density of deposit only. Combining results such as shown

in Fig. 2 with determinations of the rate of vaporization of barium oxide, it is calculated that the principal maximum of emission occurs when there are approximately 2.4×10^{14} oxide molecules per cm^2 of secondary. This is reckoned to be not more than 30 per cent. of the number required to form a

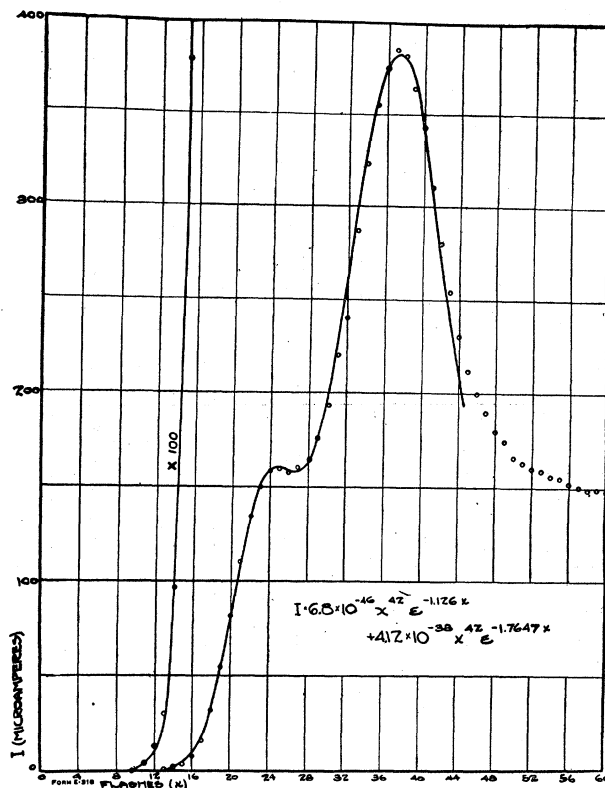

Fig. 2.

layer one molecule deep and one cm^2 in area. s turns out to be about $1.7 \times 10^{-13} \text{ cm}^2$, an area large enough to accommodate 135 barium oxide molecules.

RESEARCH LABORATORIES OF THE AMERICAN TELEPHONE & TELEGRAPH COMPANY
AND WESTERN ELECTRIC COMPANY, INCORPORATED,
April 6, 1920.

THE IONIZATION AND RESONANCE POTENTIALS OF NITROGEN, OXYGEN AND HYDROGEN.

BY F. L. MOHLER AND PAUL D. FOOTE.

THE critical potentials for electron currents in the gases were observed in a four electrode vacuum tube. The resonance potentials were obtained by observing the voltage intervals between points of completely inelastic

collision; the ionization potentials by the Lenard method. In nitrogen and hydrogen the latter method also showed sharply the occurrence of radiation at the resonance potential due to its photo-electric effect on the outer electrode but in oxygen this effect was small and too indefinite for accurate measurement. The method of Davis and Goucher for distinguishing between radiation and ionization effects was applied to hydrogen but with the result that only radiation was observed at the first critical point and ionization at the two higher points. More accurate measurement of the critical potentials was made by the methods used with the other gases.

Bohr's theory predicts the resonance and ionization potentials of atomic hydrogen and the ionization potential for molecular hydrogen. The resonance potential of nitrogen corresponds by the quantum relation to an isolated doublet observed by Lyman at $\lambda = 1494 \text{ \AA}$.

The following table shows the results obtained and the theoretical interpretation in the case of hydrogen.

Gas.	Resonance Potential.		Ionization Potential.	
	Observed.	Theoretical.	Observed.	Theoretical.
Nitrogen.....	$8.25 \pm .1$	8.26	$16.9 \pm .5$	—
Oxygen.....	$7.87 \pm .1$	—	$15.4 \pm .5$	—
H ₂	—	—	$16.4 \pm .5$	16.2
H ₁	$10.6 \pm .5$	10.1	$13.1 \pm .5$	13.5

Work required to dissociate, H₂.

Observed $16.4 - 13.1 = 3.3$ volts.

Bohr's theory = 2.7 volts.

Langmuir (Experimental) = 3.9 volts.

BUREAU OF STANDARDS,
WASHINGTON, D. C.,
April 3, 1920.

THE LOAD ON THE MODULATOR TUBE IN RADIO TELEPHONE SETS.

BY E. S. PURINGTON.

IN radio telephone equipment employing electron tubes, the function of the modulator is to vary at audio frequency the power supplied to a generator of radio frequency. It functions as an audio frequency power amplifier, and the amplifier load may be specified in terms of harmonic analysis of the wave forms of plate voltage and plate space current. Ordinarily this load or output impedance approximates a resistance, but reactive components arise as follows:

1. Imperfections in the audio-frequency choke coil in the lead from the high voltage plate power source result in an inductive component to the output impedance.

2. In the generating system either a choke coil of high radio-frequency

reactance, or bypass condenser of low radio-frequency reactance are required. The audio-frequency reactance of these and other parts of the generating circuit results in a reactive component of output impedance, which may be inductive or capacitive, depending on the circuit.

3. To modulate the current in a resonance circuit, power must be supplied not only to balance the resistance losses, but also to change the amount of energy present in the electromagnetic field of the antenna or oscillating circuit. This effect results in a capacitive component to the output impedance of the modulator tube.

While the effect due to imperfections of the audio-frequency choke coil is of primary importance in short range telephone sets, the other effects become of importance in the operation of long distance sets, in wire radio telephony and other multiple modulation methods of communication.

RADIO LABORATORY,
BUREAU OF STANDARDS,
WASHINGTON, D. C.

OPERATION OF AN ELECTRON TUBE AS AN AMPLIFYING RECTIFIER.

BY LEWIS M. HULL.

THE operation of a three-electrode electron tube as a detector in a radio receiving circuit is usually a complicated process, involving a number of apparently unrelated properties of such a tube, and it is necessary carefully to separate the various phenomena which determine its behavior, paying particular regard to the effect of the tube upon its associated circuits. It has often been stated, in descriptions of theories only partially covering the operation of tubes in this capacity, that a detector tube is a potential-operated device, taking no power from the radio receiving circuit in which currents are induced by the incoming wave trains. Strictly speaking, this is untrue under any operating conditions, and when grid rectification is employed the power taken from the receiving circuit by the detector may represent a large part of the total power derived from the incoming wave; that is, the effective resistance of the receiving circuit is due chiefly to the detector.

It is a well-known fact that a radio detector, or device for changing modulated radio-frequency currents into audio-frequency currents, must be primarily a rectifier. If it combines the property of power amplification with that of rectification (in other words, if the audio-frequency power dissipated in the receiving telephones is greater than the radio-frequency power supplied to the detector) so much the better. In order for any electrical instrument to function as a rectifier it must possess the property of wave distortion: the current which flows through it or through some associated circuit as a result of any applied voltage, must be a non-linear function of that voltage. The amount of rectification attained by a detector depends upon the character of the distortion impressed upon these alternating currents flowing as a result of the applied alternating voltage.

Two of the volt-ampere characteristics of a three-electrode electron tube are notably non-linear in certain regions: the grid-voltage, grid-current characteristic in the region of zero grid voltage, and the grid-voltage, plate-current characteristic in the region of negative grid voltage. When operating as a detector by virtue of the curvature of the grid-current characteristic (grid rectification) a high resistance is connected in series with the grid-filament circuit and the radio-frequency input E.M.F., this resistance being by-passed by a radio-frequency capacity. The current flowing in this circuit as a result of the application of an oscillating voltage of zero average value has a direct component, and the mean voltage of the grid with respect to the filament changes during a wave-train. This change in the mean grid voltage is amplified in the plate circuit and releases, from the plate battery, power for the operation of telephone receivers considerably in excess of the power dissipated in the grid circuit. When operated as a detector by virtue of the curvature of the plate-current characteristic (plate rectification), the mean grid voltage is maintained considerably negative by means of a battery, and the grid-filament circuit is connected directly in series with the source of radio-frequency E.M.F.; the result of a wave train applied to the grid is to cause a transient unidirectional component of current to flow in the plate circuit which may or may not represent an amplification of power. Usually, however, the power consumed in the grid circuit at negative grid voltage is relatively minute, since no electron current flows in the grid circuit.

In the present paper the rectification and amplification given by a tube are defined for both conditions of operation in terms of the volt-ampere characteristics, and the effects of the tubes upon the radio receiving circuit are considered separately. The latter are two in number: the direct absorption of power by the grid circuit determined by the grid-filament resistance, or the first derivative of grid voltage for grid current, and the absorption of power by the plate circuit through the inter-electrode capacity couplings, which becomes important at radio frequencies.

If the input voltage be assumed to be a series of radio-frequency waves, completely modulated at an audio frequency, the expression for this voltage for the simple case of no audio-frequency harmonics is:

$$e = E (1 + \sin pt) \sin \omega t, \quad (1)$$

where p is the audio angular frequency and ω is the radio angular frequency.

When grid rectification is used, the following relation exists, with certain approximations, between the effective value of the audio-frequency voltage e_p applied to telephone receivers in the plate circuit of the tube, and the input voltage e , defined by equation (1):

$$e_p = 1.94 \delta_g e^2, \quad (2)$$

where

$$\delta_g = \frac{\mu g Z_p}{4 \left(g + \frac{1}{R} \right) (R_0 + Z_p)}.$$

- μ = amplification constant of tube.
 Z_p = audio-frequency telephone impedance.
 R = series grid resistance.
 R_0 = internal output resistance.
 g = grid-filament resistance.
 $\dot{g} = \frac{\sigma g}{\sigma e_g}$ (partial derivative).

If the detector is connected across the terminals of a condenser in the receiving circuit of capacity C , then the input voltage in terms of a voltage e_r induced in the receiving circuit by the antenna is given by

$$e = \frac{e_r}{R'\omega C + \frac{g}{\omega C}},$$

which decreases with increasing values of the grid conductance, g .

When plate rectification is used, with the same wave-form of input voltage, the audio-frequency telephone voltage is given by:

$$e_p = 1.94\delta_p e^2,$$

where

$$\delta_p = \frac{\dot{g}_m Z_p}{4}.$$

\dot{g}_m = the derivative of the mutual conductance of grid on plate with respect to grid voltage. Since the grid conductance is infinite, the effective E.M.F. applied to the detector, in terms of the effective E.M.F. induced in the receiving circuit is, for long wave-lengths

$$e = \frac{e_r}{R'\omega C}.$$

These expressions can be checked experimentally by the measurement of g , \dot{g} , and \dot{g}_m with an audio-frequency bridge.

RADIO LABORATORY,
 BUREAU OF STANDARDS,
 WASHINGTON, D. C.

CAPACITIVE COUPLING IN RADIO CIRCUITS.

BY L. E. WHITTEMORE.

COUPLING between radio circuits may be one of three kinds:

(a) *Direct*, by connection across an inductance coil, a condenser, or a resistor.

(b) *Inductive*, by the linking of the electromagnetic fields of two inductance coils, one in each circuit. In this case a mutual inductance is common to both circuits.

(c) *Capacitive*, by the linking of the electrostatic fields of two condensers in the two separate circuits. In this case a condenser has one plate connected to each of the two circuits.

A combination of these methods is frequently found in practice.

Capacitive coupling is used in one type of radio receiving apparatus and has been proposed for use in transmitting sets. It is valuable as a coupling between resonant circuits for radio measurements since its value can be accurately calculated. It is also used between the stages of radio frequency amplifiers. Two circuits are frequently coupled capacitively because of the

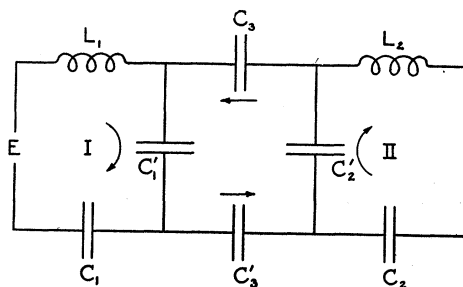

Fig. 1.

proximity of parts between which only mutual inductance is desired. It may often be advisable to replace such coupling by capacitive coupling alone.

Figure 1 shows a typical radio circuit having capacitive coupling between circuits I. and II. The equations for the potential drops in this circuit are as follows:

$$i_1 \left(j\omega_1 L_1 + \frac{1}{j\omega_1 C_1} \right) + \frac{i_1'}{j\omega_1 C_1'} = 0,$$

$$i_2 \left(j\omega_2 L_2 + \frac{1}{j\omega_2 C_2} \right) + \frac{i_2'}{j\omega_2 C_2'} = 0,$$

$$\frac{i_1'}{j\omega_1 C_1'} + \frac{i_3}{j\omega_3 C_3} + \frac{i_3}{j\omega_3 C_3'} + \frac{i_2'}{j\omega_2 C_2'} = 0,$$

$$i_1' = i_1 + i_3,$$

$$i_2' = i_2 + i_3.$$

It is assumed that currents of the same frequencies exist throughout the circuit, *i.e.*, $\omega_1 = \omega_2 = \omega_3$.

Case I.—If the frequencies of circuits I. and II. when the coupling condenser C_3 and C_3' are disconnected, are made equal, *i.e.*,

$$\frac{1}{L_1} \left(\frac{1}{C_1} + \frac{1}{C_1'} \right) = \frac{1}{L_2} \left(\frac{1}{C_2} + \frac{1}{C_2'} \right) = 4\pi^2 n^2,$$

where n is the natural frequency of each circuit, the two frequencies present

in both circuits when coupled are given by,

$$\omega' = 2\pi n,$$

$$\omega'' = \sqrt{4\pi^2 n^2 - \frac{C_t}{L_1 C_1'^2} - \frac{C_t}{L_2 C_2'^2}},$$

where

$$\frac{\omega'}{\omega''} = \sqrt{\frac{1+k_e}{1-k_e}}.$$

The ratio of corresponding wave-lengths can be expressed as

$$\frac{\lambda'}{\lambda''} = \sqrt{\frac{1-k_e}{1+k_e}}.$$

It is to be noted that for all values of k_e the frequency corresponding to ω' and λ' is the frequency to which the circuits were originally tuned. The other becomes zero as k_e becomes unity.

$$\omega'' = 2\pi n \sqrt{\frac{1-k_e}{1+k_e}}.$$

The constant k_e can be defined as the coefficient of capacitive coupling and its value in terms of the capacities of the circuit is given by

$$k_e^2 = \left(\frac{C_t}{C_1' C_2'}\right)^2 G_1 G_2,$$

where

$$\frac{1}{G_1} = \frac{1}{C_1} + \frac{1}{C_1'} - \frac{C_t}{C_1'^2},$$

$$\frac{1}{G_2} = \frac{1}{C_2} + \frac{1}{C_2'} - \frac{C_t}{C_2'^2}$$

and

$$\frac{1}{C_t} = \frac{1}{C_1'} + \frac{1}{C_2'} + \frac{1}{C_3} + \frac{1}{C_3'}.$$

Case 2.—If the circuits I. and II. are each in turn connected to the coupling condensers and tuned to the same frequency (the inductance and capacity of the other circuit being disconnected in each case) we have $L_1 G_1 = L_2 G_2$ and

$$\omega' = \sqrt{\frac{1+k_e}{L_1 G_1}},$$

$$\omega'' = \sqrt{\frac{1-k_e}{L_1 G_1}}.$$

The ratio of the wave-lengths is as before,

$$\frac{\lambda'}{\lambda''} = \sqrt{\frac{1-k_e}{1+k_e}}.$$

The two frequencies are

$$n' = n \sqrt{1 + k_e}$$

and

$$n'' = n \sqrt{1 - k_e}.$$

Experiments give results which correspond to this value and show that maximum current is present in circuits I. and II. when the ratio of the two wave-lengths is an integer. Cathode-ray oscillograms bear out this conclusion.

In special cases the expressions may be greatly simplified by making some of the capacities infinite, that is, by short circuiting some of the condensers.

RADIO LABORATORY,
BUREAU OF STANDARDS,
WASHINGTON, D. C.

AN AIR DISTANCE RECORDER.¹

BY CHARLES H. COLVIN, M.E.

THE air distance recorder, or integrating air speed meter, is an adaptation of the well-known recording anemometer. It is, however, far more accurate than the usual recording anemometer, because it is used at speeds which give a large amount of power available for driving the mechanism; and as the load on the instrument increases much more slowly than the increase in the power of the moving air, the error becomes less and less as higher speeds are reached, provided the blades have been properly designed for the high speed.

Time does not permit an extended discussion of the subject, or even a complete description of the mechanism. As the accuracy of the apparatus depends solely upon the characteristics of the transmitter which is acted upon by the passing air (assuming proper mechanical construction of the recording mechanism) the discussion will be confined to that part of the apparatus.

The form of wind-vane which was adopted after tests on various types consisted of two blades, each circular and of $1\frac{1}{2}$ in. diameter and $\frac{3}{8}$ in. thickness, carried on $\frac{1}{8}$ in. diameter arms of such length that the centers of the blades were 3 in. from the axis. The hub into which the arms were fastened was 1 in. in diameter, forming a stream-lined nose for a 1 in. tube carrying the gear-reduction mechanism. With this form of blade, the disturbance around the hub was eliminated as far as possible, and the pitch over the surface of the blade was practically uniform.

With the gear reduction which was employed, the proper path of the blades was a helix of an angle of 34.67° with the axis (calculations made to the center of the blade) to give one indication per mile.

In order to determine the angle of incidence at which the blades should be set away from this angle of 34.67° , experiments were made to determine the air friction on the blades and arms at different speeds, and of the mechanical

¹ Abstract of a paper presented at the Washington Meeting of the American Physical Society, April 25 and 26, 1919.

friction of the mechanism. It was assumed that the proper angle of incidence would be found to be less than 1° , and tests were made for air friction at both 0° and 1° incidence. The figures at 1° were found to be about 20 per cent. higher than at 0° , and these figures were used to be on the safe side. These values are shown in curve 1 of Plate I. Here the speed of the blade in feet per second is plotted against the resistance of the blade in pounds (at the center of the blade = at 3-inch radius).

The motion of the blade, however, has two components as indicated in Fig. 1, where B is the component in the direction of flight, and C is the com-

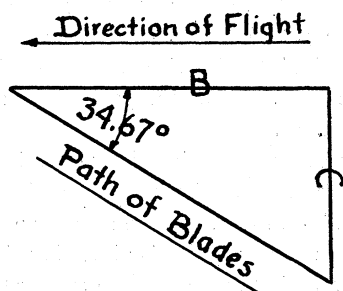

Fig. 1.

ponent in the direction of rotation. With the blade path at the predetermined angle of 34.67° with the axis, $B = .8225$ and $C = .5688$ of the speed of the blade. The resolution of the force on the blade, as shown in curve 1, is in the same proportion, B being the axial force, and C the force which must be overcome by the driving pressure of the air on the blades.

To C must be added the mechanical friction. As the mechanism was carried on ball bearings this was very low, and as near as could be determined equalled .003 inch-pounds, or .001 pound at 3 in. radius. This appeared to vary but slightly with speed, and was taken as constant. The values of C for different speeds of the blades are plotted in curve 2 of Plate I., the value of the mechanical friction shown by line 3, and their sum shown as curve 4.

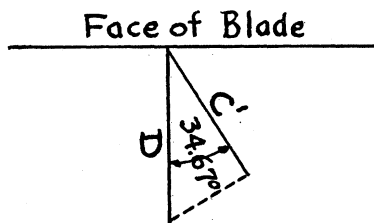

Fig. 2.

The force normal to the blade necessary to produce the force C plus mechanical friction, or C' , is shown in Fig. 2, as $D (= 1.215 C')$. The values of D are plotted as curve 5 of Plate I.

The angles of incidence necessary to give the normal force D , were calculated from Eiffel's formula: $P_a = P_{90} \cdot a/25$. (P_a = pressure at desired angle of incidence, P_{90} = pressure at 90° , a = angle of incidence in degrees.) It was decided to set the blades correctly for 90 miles per hour and sea-level.

As the blades move on a path at 34.67° with the axis, they move at 1.215 times the speed of the plane, or at 109 miles an hour or 160 feet per second, for 90 mile speed of the plane. Calculating the pressure which would be exerted on the blades if revolved flat at this speed, and using the value of D from the curve 5, in the above formula, we find the proper angle of incidence to be 0.17° . This is added to the angle 34.67° , giving 34.84° as the proper blade setting.

The error due to the changing angle of incidence at different speeds and altitudes is now simply calculated by the same method, the angular error of the path from the prescribed angle of 34.67° being found and from that the error in the indicated distance.

It will be noted that certain approximations have been made in the above calculations, but the errors introduced thereby have been negligible.

The results of the calculation of errors are shown on the curves of Plate II. Distance indicated for 100 miles travelled is plotted against speed of the plane: at sea-level, at 10,000 feet, and at 20,000 feet, in curves 1, 2 and 3, respectively. In the calculations for 10,000 and 20,000 feet, it was assumed that the air friction, depending on the viscosity of the air, remains constant. Should this decrease, the errors found would decrease accordingly.

It will be seen that at sea-level the greatest error is 0.1 per cent., and at 20,000 feet a maximum error is found of less than 0.7 per cent.

The apparatus has been subjected to exhaustive tests in flight, and the trials appear to check these figures.

Thus it is seen that the air distance recorder is an instrument of extreme accuracy under all conditions, and as it becomes more generally known, it is certain to find a very large field of usefulness as an aircraft navigating instrument.

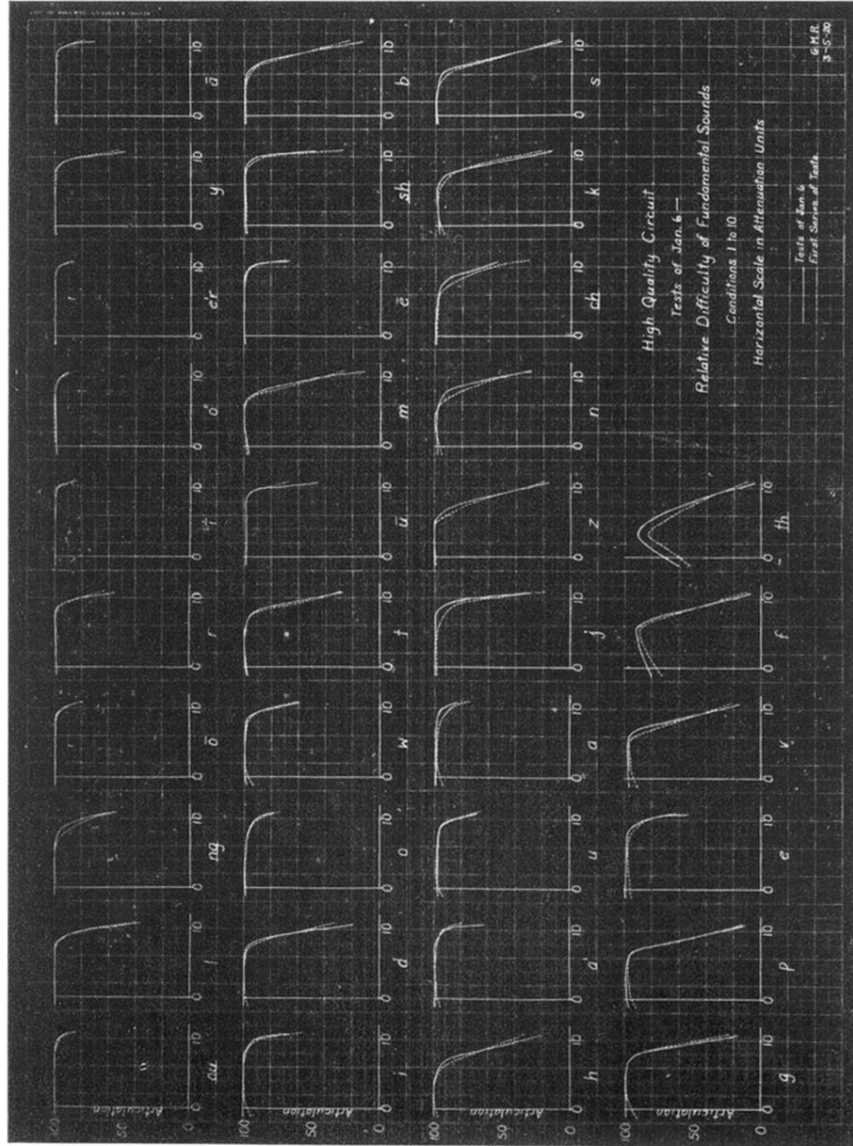

Fig. 2.