

## Effect of Gravity on Gamma Radiation\*

R. V. POUND AND J. L. SNIDER

*Laboratory of Physics, Harvard University, Cambridge, Massachusetts*

(Received 26 May 1965)

Recoil-free resonant absorption of the 14.4-keV  $\gamma$  ray in  $\text{Fe}^{57}$  has been employed to measure the effect of gravity over a 75-ft vertical path in the Jefferson Laboratory, in an improved version of the experiment of Pound and Rebka. A  $\text{Co}^{60}$  source, initially 1.25 Ci, large-windowed proportional counters, and an enriched absorber foil 15 in. in diameter permitted a much increased counting rate. The employment of temperature-regulated ovens for source and absorbers and a redesigned monitor system to detect variations in waveform of the source velocity effected a reduction in systematic uncertainties. The result found was  $(0.9990 \pm 0.0076)$  times the value  $4.905 \times 10^{-16}$  of  $2gh/c^2$  predicted from the principle of equivalence. The range given here is the statistical standard deviation set by the number of counts involved. An estimated limit of systematic error is 0.010.

### INTRODUCTION

MORE than fifty years have elapsed since Einstein proposed what has come to be called the "principle of equivalence," a generalization of the results of the experiments of Eötvös on the proportionality of mass and weight.<sup>1</sup> Einstein proposed that no local experiment of any kind could distinguish between the effects of a gravitational field, on the one hand, and the effects of a uniform acceleration of the laboratory with respect to an inertial frame, on the other. In particular, if a source of radiation were to be viewed from a distance  $h$  below it, in a region having a uniform gravitational field of such strength that the acceleration of bodies in free fall were  $g$ , the observer should find the same properties that would be found if the whole laboratory were free of gravitation but were accelerating upward at the rate  $g$ . In this latter situation the velocity change taking place during the time of transmission of a given part of the radiation puts the observer at an effective velocity  $\Delta V = gh/c$ . Therefore, one predicts that if a source of radiation at a height  $h$  above an observer were given an upward velocity  $gh/c$ , the effect of gravity would be cancelled.

It is advantageous experimentally to seek the condition that would make an observer below the source see exactly the same properties he finds when making an observation from the same height above it. By such means, other distance-dependent factors in the experimental situation are removed. It is then the prediction that a source velocity difference equal to  $2gh/c$  between the two arrangements should make observations in the two situations identical.

In the above description no mention has been made of frequency or wavelength. The similar effect so intensively sought in stellar and solar spectra over the years is most often described in terms of the expected shift in the position of spectral lines, in the absence of a compensating velocity. So long as the velocity difference is small compared to  $c$ , its effect would be to produce, as

a Doppler effect, a frequency or wavelength shift amounting fractionally to  $gh/c^2$  for a one-way path. In a nonuniform gravitational field appropriate to astrophysics the argument is easily generalized to predict a fractional shift  $\Delta\nu/\nu_0 = -\Delta\phi_g/c^2$ , where  $\Delta\phi_g$  is the increase in gravitational potential over the path from source to observer, so long as  $\Delta\phi_g/c^2 \ll 1$ . The present experiment makes no direct determinations of either frequency or wavelength. The determination of a compensating source velocity is an exact operational description of the experiment.

It is not our purpose here to enter into the many-sided discussion of the relationship between the effect under study and general relativity or energy conservation. It is to be noted that no strictly relativistic concepts are involved and the description of the effect as an "apparent weight" of photons is suggestive. The velocity difference predicted is identical to that which a material object would acquire in free fall for a time equal to the time of flight.

We wish only to make some limited remarks as to the status of astronomical studies and, therefore, the relevance of an earth-bound experiment. Clearly there are other contributions to the displacement and shape of stellar and solar spectral lines of at least comparable magnitude to the predicted gravitational shift. From solar studies it is particularly clear that these other contributions introduce problems of interpretation of observation. Before the effect of gravity can be isolated from the observations, an exact quantitative knowledge of these other factors must be available. A terrestrial experiment, on the other hand, offers the possibility of studying an effect that correlates only with a change of the gravitational contribution, with all other contributions held constant or compensated. For this reason the interpretation is far less subject to error even when the effect measured is fractionally only  $10^{-9}$  times as large as the solar effect, as in the experiments to be described.

### APPLICATION OF MÖSSBAUER EFFECT

The discovery by Mössbauer that  $\gamma$  rays of low energy can be emitted and absorbed by nuclei bound in solids

\* A short description of this experiment and its results has been published in *Phys. Rev. Letters* **13**, 539 (1964).

<sup>1</sup> A. Einstein, *Jahrb. Radioakt. u. Elektronik* **4**, 411 (1907); *Ann. Physik* **35**, 898 (1911).

without recoil or broadening from thermal agitation<sup>2</sup> brought with it the possibility of the development of a system of adequate sensitivity to detect the gravitational effect using a moderate height difference.<sup>3,4</sup> For this application the first suitable  $\gamma$  ray to be found<sup>5,6</sup> and still the best known at the time of writing is the 14.4-keV transition from the 0.1- $\mu$ sec first excited state of Fe<sup>57</sup>. Two other isotopes having, in principle at least, fractionally narrower resonance lines, have been studied, namely, Zn<sup>67</sup><sup>7-10</sup> and Ta<sup>181</sup>.<sup>11,12</sup> So far it has not proved possible to use these isotopes in situations of practical significance. The reasons for this are not entirely clear but arise partly from the presence of extraneous broadening interactions, such as quadrupole couplings to the crystalline field and isomer or chemical shifts, and partly from the extraordinarily small vibrational velocities that can be tolerated without interference with the resolution of the line. In fact the resolution possible with a resonance absorption line is determined by other factors in addition to the fractional linewidth. In practice, the problem is to detect the smallest possible fractional change of the effective frequency of a source relative to an absorber. Clearly, when counting statistics are considered, the best situation will result if the rate of change of transmission with relative velocity is made a maximum. In determining such a slope, the depth of the absorption line is as important as its fractional width and it is in this respect that Fe<sup>57</sup> is difficult to improve upon. For a given slope, a further advantage accrues to a broad line because vibrations need be suppressed only to the degree that velocities due to them are all within the range of essentially constant slope, thereby avoiding rectification.

The situation may be analyzed quantitatively with the help of Fig. 1. This shows a curve of the counts observed in a standard time interval through a resonant absorber as a function of a superposed source velocity  $V$  toward or away from the absorber. A small displacement of the source frequency relative to the absorber

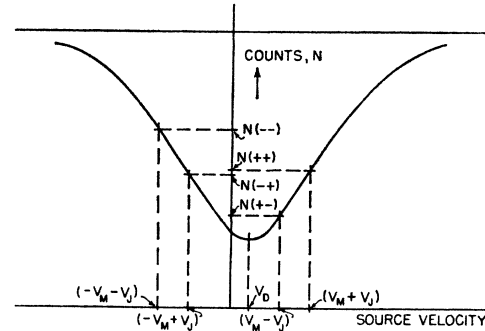

FIG. 1. The solid curve illustrates the counting rate versus source velocity for a resonant absorption line. The four rates corresponding to the combinations of  $\pm V_M$  and  $\pm V_J$  allow the precise determination of the effective displacement  $V_D$  of the line center in terms of  $V_J$ .

has been assumed so that maximum absorption occurs for a velocity  $V_D$ , taken as positive in the example. The velocity  $V_D$  is, for the gravitational effect of interest here, only about 1/500 of  $V_H$ , the velocity for half-maximum absorption. To make best use of the resonance line to measure this displacement, one must add velocities  $+V_M$  and  $-V_M$ , where  $V_M$  approximates the points of steepest slope in the line, and compare the transmission for these. Two such counts for equal times could be used to evaluate the shift  $V_D$  if the line shape, depth and width were accurately known. To avoid detailed evaluation of these parameters and to reduce the requirement on their constancy over the course of measurements, an additional bidirectional velocity  $+V_J$  and  $-V_J$  may be added, where  $V_J$  is larger than  $V_D$  but still much smaller than  $V_H$ , to allow the slope of the line to be regarded as constant over the range from  $V_M + V_J$  to  $V_M - V_J$  and in a similar range around  $-V_M$ . One then obtains four numbers  $N(++), N(-+), N(+),$  and  $N(--)$ , corresponding to the counts collected with the respective velocities  $+V_M + V_J, -V_M + V_J, +V_M - V_J,$  and  $-V_M - V_J$ .

An expression for the number of counts for a standard time versus source velocity, representing an approximation to the resonance line shape, may be taken as

$$N(V) = Nb(\Omega/4\pi)\epsilon D \times \{1 - F[1 + ((V - V_D)/V_H)^2]^{-1}\}, \quad (1)$$

where  $N$  is the number of decays of the source,  $b$  is the fraction of decays leading to emission of the  $\gamma$  ray in question,  $\Omega/4\pi$  is the fraction of radiations intercepted by the detector,  $\epsilon$  is a factor allowing for detector efficiency and nonresonant absorption,  $D$  is a duty cycle, and  $F$  is a fraction measuring the depth of the line.

In practice the velocity  $\pm V_M$  is applied as an audio-frequency ( $\sim 70$  cps) modulation by means of a ferroelectric transducer. An electronic gate assures very precisely equal times for  $+V_M$  and  $-V_M$ . Consider the quantities

$$\Delta^+ = [N(++)-N(-+)]/[N(++)+N(-+)]$$

<sup>2</sup> R. L. Mössbauer, in *The Mössbauer Effect*, edited by H. Frauenfelder (W. A. Benjamin, New York, 1962), pp. 101-135.

<sup>3</sup> R. V. Pound and G. A. Rebka, Jr., *Phys. Rev. Letters* **3**, 439 (1959).

<sup>4</sup> I. Ya. Barit, M. I. Podgoretskii, and F. L. Shapiro, *Zh. Eksperim. i Teor. Fiz.* **38**, 301 (1960) [English transl.: *Soviet Phys.—JETP* **11**, 218 (1960)].

<sup>5</sup> R. V. Pound and G. A. Rebka, Jr., *Phys. Rev. Letters* **3**, 554 (1959).

<sup>6</sup> J. P. Schiffer and W. Marshall, *Phys. Rev. Letters* **3**, 556 (1959).

<sup>7</sup> R. V. Pound and G. A. Rebka, Jr., *Phys. Rev. Letters* **4**, 337 (1960).

<sup>8</sup> D. E. Nagle, P. P. Craig, and W. E. Keller, *Nature* **186**, 707 (1960).

<sup>9</sup> P. P. Craig, D. E. Nagle, and D. R. F. Cochran, *Phys. Rev. Letters* **4**, 561 (1960).

<sup>10</sup> S. I. Aksenov, V. P. Alfimov, V. I. Lushchikov, Yu. M. Ostanevich, F. L. Shapiro, and Yen Wu-Kuang, *Zh. Eksperim. i Teor. Fiz.* **40**, 88 (1961) [English transl.: *Soviet Phys.—JETP* **13**, 63 (1961)].

<sup>11</sup> S. G. Cohen, A. Marinov, and J. I. Budnick, *Phys. Letters* **12**, 38 (1964).

<sup>12</sup> W. A. Steyert, R. D. Taylor, and E. K. Storms, *Phys. Rev. Letters* **14**, 739 (1965).

and

$$\Delta^- = [N(+ -) - N(- -)] / [N(+ -) + N(- -)].$$

Since  $\Delta^+$  and  $\Delta^-$  are each fractions representing the differences per count in independent runs with  $+V_J$  and  $-V_J$ , respectively, it is not necessary for the times for these runs to be accurately equal. In our apparatus the velocity  $V_J$  is applied through an hydraulic piston and alternation between  $+V_J$  and  $-V_J$  occurs only at approximately 5-min intervals to avoid a large fractional time loss during reversals. By normalizing the differences in this way, the presence of instrumental variations such as lead to drift in the counting rate over the periods of alternation of  $V_J$  are of little importance.

An expansion in Taylor series about  $V = \pm V_M$  of Eq. (1) allows evaluation of  $V_D$  in terms of  $V_J$ . In particular, using only the linear term in  $V_J$  and taking the value  $V_M^2 = \frac{1}{3}V_H^2$  which corresponds to maximum slope for the form assumed in Eq. (1), one obtains

$$\Delta^+ - \Delta^- = +[3\sqrt{3}F/(4-3F)](|V_J|/V_H), \quad (2)$$

and

$$\Delta^+ + \Delta^- = -[3\sqrt{3}F/(4-3F)](V_D/V_H). \quad (3)$$

A sensitivity factor  $S$  defined as

$$S = |V_J|/[c(\Delta^+ - \Delta^-)] \quad (4)$$

allows evaluation of an effective asymmetry  $a_D$  of the fractional velocity offset  $V_D$  in units of the velocity of light  $c$ , as

$$a_D = +V_D/c = -(\Delta^+ + \Delta^-)S. \quad (5)$$

The quantity  $S$  itself, evaluated from run to run, provides a continuous measure of the stability of the system. Any significant changes in it indicate the presence of some spurious interference, such as vibration. If the quantity  $F$  is known, the factor  $S$  can be converted into the fractional linewidth

$$V_H/c = [3\sqrt{3}F/(4-3F)]S, \quad (6)$$

still assuming the Lorentzian shape of Eq. (1). It is important to note that Eq. (5) assumes only the existence of essentially constant slopes in the regions of  $\pm V_M$  and may be applied independently of true line shape.

The evaluation of the statistical standard deviation associated with a given determination of  $a_D$  is straightforward. The four numbers  $N(++)$ ,  $N(-+)$ ,  $N(+ -)$  and  $N(- -)$  are in practice very nearly equal. The standard deviation of each quantity  $\Delta^\pm$  is  $[N(+\pm) + N(-\pm)]^{-1/2}$ . The standard deviation of each of  $(\Delta^+ \pm \Delta^-)$  is approximately  $2[N(++) + N(+ -) + N(- +) + N(- -)]^{-1/2}$ . Because only small net displacements  $V_D$  are of concern, use of a value of  $V_J$  approximately ten times larger than  $V_D$  then makes  $|\Delta^+ - \Delta^-|$  correspondingly larger than  $|\Delta^+ + \Delta^-|$  and negligible contribution to the net standard deviation in  $a_D$  results from the standard deviation in the corresponding measurement of the sensitivity factor  $S$ . A final value for the

statistical contribution to the uncertainty is then expressed as the standard deviation  $\delta a_D$  in the asymmetry

$$\delta a_D = 2S[N(++) + N(+ -) + N(- +) + N(- -)]^{-1/2}. \quad (7)$$

This can be written for the assumed Lorentzian shape as

$$\delta a_D = [(1 - \frac{3}{4}F)/3N_0]^{1/2} \times 8V_H/3Fc, \quad (8)$$

where  $N_0$  is the total number of counts that would have been collected in the absence of the resonant absorption. In terms of the time of the run  $\tau$  and the source strength  $R$  decays per unit time, this number is

$$N_0 = R\tau b\Omega\epsilon D/4\pi. \quad (9)$$

From Eq. (8), for a given useful source strength and for  $F$  much smaller than one, the figure of merit for an example of recoil-free resonance is  $V_H/F$ . The ease of achieving a large value of  $F$  with the  $\text{Fe}^{57}$  resonance line is the reason that it is as yet unsurpassed as a medium to detect small fractional shifts of frequency. Especially convenient is the fact that no low-temperature environment is required to obtain the high resolution.

The precision of a given determination of  $a_D$  is, beyond the statistical uncertainty, directly proportional to the precision of the quantity  $V_J$  to the extent that the conditions of Eq. (5) apply. In the interest of minimizing the statistical contribution to  $a_D$  from  $S$ ,  $V_J$  should be large. On the other hand, too large a value of  $V_J$  complicates the procedure somewhat when high absolute precision is desired. One may carry out the analysis, including higher terms in the Taylor expansion, and obviously the result is dependent on the functional shape assumed for the resonance line. For lines of even symmetry only odd-powered terms contribute. For the Lorentzian of Eq. (1) one finds, still using  $V_M^2 = V_H^2/3$ ,

$$a_D' \approx a_D[1 + \frac{3}{2}(V_J/V_H)^2], \quad (10)$$

where  $a_D$  is the result of applying Eq. (5), i.e.,  $-(\Delta^+ + \Delta^-)S$ , and  $a_D'$  is the true asymmetry  $V_D/c$ . An exact line profile would be needed to determine a practical correction factor to modify the linear example. A line profile determined in the early experiments,<sup>5</sup> even though broadened considerably and measured with poor velocity stability, fit a Lorentzian curve surprisingly closely.

A complication arises with the employment of  $\text{Fe}^{57}$  owing to the ferromagnetism of iron. The presence of an internal magnetic field and its resultant hyperfine structure reduces the intensity of resonant absorption relative to nonresonant absorption and therefore the magnitude of  $F$  that can be achieved without serious reduction in the counting rate. In addition the well-known six component structure of the radiation and correspondingly of the absorption can give rise to significant broadening of the central main resonance even though each component of the source radiation in principle resonates with its mate in the absorber, at

zero relative velocity. Such broadening can result from small magnetic difference between pieces of the absorber and of the source, slightly degrading the overlap of the components at a single velocity. The source strength desired could involve introduction into the iron of sufficient cobalt in itself to perturb the field in the source away from that of pure iron. Such internal field variation has been studied in iron-cobalt alloys.<sup>13</sup>

To avoid such problems it might be supposed that a nonmagnetic carrier would prove advantageous. However, although the lines in nonmagnetic stainless steels prove to be unsplit, they are so much broadened, probably as the result of irregularity in the local structures with resultant variations of isomer shift and/or quadrupole interactions, that in practice less resolution seems to be available than with iron. Unfortunately, the use of copper or platinum as a source matrix, although it results in a single relatively unbroadened emission line, does not lend itself to this application because a corresponding resonant, single-line absorber is not readily available. The best over-all combination appears still to be an iron source and an iron absorber enriched in Fe<sup>57</sup>. An improvement by about two in the ratio of resonant to nonresonant absorption is obtained through the application of sufficiently strong magnetic fields to polarize the source and absorber parallel to one another and transverse to the direction of the radiation.<sup>14</sup> Perhaps more important for this experiment is the fact that permanent magnets fixed to the source and absorber units also reduce any possible effects on the resonance that could result from translation and reorientation of the system relative to the magnetic field of the earth.

The experiment to be described here represents an extension to a higher precision of the earlier work of Pound and Rebka. That earlier work demonstrated conclusively the existence of the gravitational effect. In the course of that work the effect of temperature on the energy of the  $\gamma$ -ray emission and absorption lines was elucidated.<sup>15</sup> With monitoring of temperatures to provide corrections, a measurement was made of the gravitational effect which agreed with the prediction to well within the uncertainties. The full data collected from that experiment had a statistical standard deviation of about 4% and an estimated limit of systematic error of about 10%.<sup>16</sup> A result of 0.859 times the expected effect with an estimated over-all standard deviation of  $\pm 0.085$

was recently reported by Cranshaw and Schiffer<sup>17</sup> who performed an experiment at Harwell similar in most respects but not including a monitor channel.

### THE NEW APPARATUS

It was felt that a number of improvements could be made to enable a new experiment to be carried to at least an order of magnitude greater precision. Three main areas of reduction in systematic uncertainties were anticipated. First and foremost was the control and measurement of the important temperatures. Second, there was much room for improvement in the reliability and functioning of the "monitor" system that provided a way to eliminate from the result any perturbing effects in the source and its motion by obtaining data with an absorber close to the source. Third, basic improvements in reliability of the gating and switching functions of the electronics were possible.

A result of some interest to the general problem of systematic errors in the experiment was reported in the interim.<sup>18</sup> This was the measurement of the rate of change of  $\gamma$ -ray frequency with hydrostatic pressure. If sufficiently large, such an effect could necessitate compensation or correction for the effect of the pressure gradient in the atmosphere. The fractional change of frequency was found to be about  $-2.6 \times 10^{-18}$  per atmosphere. The atmospheric gradient should contribute less than  $10^{-5}$  as large an effect as gravity and is, therefore, entirely negligible at the present level of precision.

An important decision had to be made between the continued use of the short vertical height available in the Jefferson Laboratory or some other site. A vertical mine shaft could have advantages in thermal and vibrational stability and any increase in vertical path would reduce the importance of sources of systematic error accordingly. Even a taller building of stability comparable to our laboratory would therefore have advantages. An increase in vertical path would, however, with a given source strength, somewhat increase the statistical uncertainty because of the increased absorption in the path. The primary effect of the linear increase in the shift would be cancelled by the inverse square loss in intensity for a given absorber area and any further distance dependent decrease in intensity would represent a degradation. The contribution to the over-all statistical uncertainty because of the finite counting rate in the monitor channel would be reduced relatively. The logistical advantages of the Jefferson site proved so dominant that we decided to try to reduce the systematic uncertainties in that site, at least as a first step. That site provided a path of length approximately 25 m from the floor of the reverberation chamber in the basement to the ceiling of the penthouse above the main

<sup>13</sup> C. E. Johnson, M. S. Ridout, and T. E. Cranshaw, *Phys. Rev. Letters* **6**, 450 (1961); *Proc. Phys. Soc. (London)* **81**, 1079 (1963).

<sup>14</sup> G. J. Perlow, S. S. Hanna, M. Hamermesh, C. Littlejohn, D. H. Vincent, R. S. Preston, and J. Heberle, *Phys. Rev. Letters* **4**, 74 (1960).

<sup>15</sup> R. V. Pound and G. A. Rebka, Jr., *Phys. Rev. Letters* **4**, 274 (1960).

<sup>16</sup> R. V. Pound and G. A. Rebka, Jr., *Phys. Rev. Letters* **4**, 337 (1960); R. V. Pound, *Usp. Fiz. Nauk* **72**, 673 (1960) [English transl.: *Soviet Phys.—Usp.* **3**, 875 (1961)]; *The Mössbauer Effect*, edited by D. M. J. Compton and A. H. Schoen (John Wiley & Sons, Inc., New York, 1962), pp. 217–219; G. A. Rebka, Jr., thesis, Harvard University, 1961 (unpublished).

<sup>17</sup> T. E. Cranshaw and J. P. Schiffer, *Proc. Phys. Soc. (London)* **84**, 245 (1964).

<sup>18</sup> R. V. Pound, G. B. Benedek, and R. Drever, *Phys. Rev. Letters* **7**, 405 (1961).

roof. Although the walls of this enclosed tower were originally entirely independent of the structure of the laboratory and therefore should, in principle, provide an ideal degree of isolation from vibration, the separation had been bridged in a few places in the course of remodeling operations over the years. The compressor unit of an A.D.L. Collins Helium Cryostat produced severe vibrations of the tower structure, apparently coupled through its foundations. The problem of regulating and monitoring the temperatures in the system was made especially severe through the absence of room heating or thermal insulation in the penthouse at the top of the system. An air-conditioning unit was installed there to try to limit the daytime temperature extremes in the summer months, but it proved to introduce such severe vibration as to render operation unreliable. An architectural drawing of the structure as it was employed is given in Fig. 2.

To enable the precision of the result to be limited as nearly as possible only by systematic uncertainties and, particularly, to make possible tests with reasonably small statistical uncertainties, it was very desirable to improve on the operation obtained by Pound and

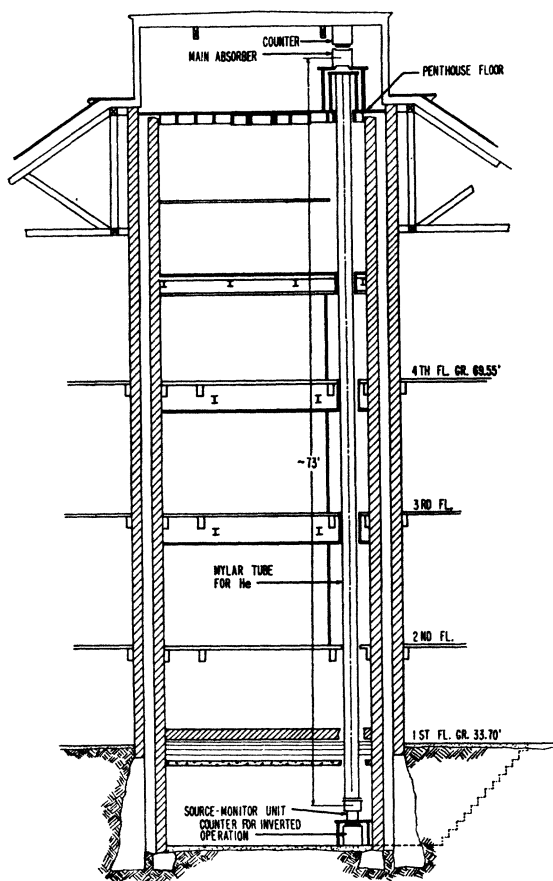

FIG. 2. An architectural sketch of the arrangement of the system in the enclosed "isolated" tower in the Jefferson Physical Laboratory.

Rebka. A direct step was an increase in initial source strength, by a factor of 5, to 1.25 Ci. Measurement standards in use at Nuclear Science and Engineering Corporation at the time led to the earlier source being mistakenly described as 0.4 Ci but it was closer to 0.25 Ci. As in the earlier experiment, the aperture available for the  $\gamma$ -ray beam was defined by a Mylar cylinder of 16-in. diameter filled at NTP with slowly flowing helium gas to avoid attenuation in air. An improvement in detector area over that of the seven scintillators, each 2 $\frac{3}{4}$ -in. in diameter, used by Pound and Rebka, was provided by a 90%-argon-10%-methane-filled proportional counter with a window 16 in. in diameter. After some unrewarding efforts to obtain improved net slope,  $F/V_H$ , from various stainless steels, effort was concentrated on obtaining a large magnetically soft iron absorber foil enriched in  $Fe^{57}$ . Over all these several improvements were expected to lead to a reduction by a factor of about 80 in the time required to obtain a given statistical uncertainty as compared to the original experiment.

The radiation length for the 14.4 keV  $\gamma$  ray corresponds to about 15 mg/cm<sup>2</sup> of iron. For good efficiency a source should be thin compared to that or at least the activity restricted to a volume nearer than that to the surface. As a precaution against the perturbation of the internal field in so thin a source by too large a concentration of impurities, a large source diameter of 4 in. was chosen. The 1.25 Ci of cobalt was electroplated onto a foil of this diameter and of thickness 5 mg/cm<sup>2</sup> made from iron enriched in  $Fe^{56}$  to 99.7% to reduce the resonant absorption by  $Fe^{57}$ . The activity was diffused throughout the foil by annealing for 24 h at 1050°C. This source, prepared by Nuclear Science and Engineering Corporation, was received in March, 1963.

About eight months of operations employed the source with an over-all system much like that of Pound and Rebka. Temperature-regulating ovens were used on the source, absorber and monitor units, and the improved aperture was obtained from the proportional counter mentioned above. The anticipated data rate was essentially achieved. Unfortunately, the internal consistency of data in a typical overnight run, from day to day or week to week, was not quite within expectations based on statistics. Almost all the data, when reduced to determine the effect relative to the monitor data correlating with inversion of the system, fell about 10% short of the predicted value. Had the internal consistency been up to expected standards, enough data were collected to yield a statistical standard deviation less than 0.5%. Considerable time and energy were expended trying to discover a spurious source of systematic error. There seemed to be evidence that the monitor channel was not providing information correctly related to that of the main absorber channel. A redesign of the basic elements of the system was undertaken in an effort to correct this situation. Several changes and improvements were made at this time, but the main source of error is believed to have been in the combination of an

inadequately designed source mounting on the transducer with the sensitivity of the monitor absorber channel to source velocities in a direction transverse to the main beam, owing to its necessarily slanting angle of view of the source. The source, which had a Lucite backing disk, was found to be inadequately stiff and, when driven at 117 cps from behind with a ferroelectric cylindrical transducer of only  $1\frac{1}{2}$ -in. diameter, there was considerable excitation of modes other than the desired pure pistonlike motion. The redesign of the system included both a very great reduction in any such spurious motions as well as a great reduction in the sensitivity of the monitor channel to transverse velocities. In addition, by enclosing the main absorber in a vacuum chamber, airborne sound was prevented from acting directly on the absorber foil. Integration of the monitor absorbers and counters mechanically with the source in a single rigid unit further reduced any vagaries originating in a difference in the methods and relative positions of mounting of these units at the two ends of the system. This new system was brought into operation in March, 1964, by which time the source had decayed to about 0.6 Ci. Operation with it was very much more consistent than before the modifications. It could be argued that the achievement of a very high data rate made possible the elimination of unanticipated spurious effects which might not otherwise have been found.

### THE FINAL OVER-ALL SYSTEM

A block diagram for the over-all system as finally evolved is shown in Fig. 3. Basically it is very similar to that of Pound and Rebka. Electronic gates accepted pulses occurring in each of the monitor and main channels in two periods, each in duration about 25% of the

period of the sine wave applied to the ferroelectric transducer centered about the extremes of velocity. A trigger pulse was generated from each direction of inversion of a monostable circuit driven from the audio oscillator through a network providing an adjustable phase shift. These pulses triggered a General Radio (GR) Model 1391-B pulse generator to form a pulse of about 3.5 msec duration. An oscilloscope so set as to start a sweep on every third trigger pulse allowed accurate equalization of the time intervals between successive trigger pulses. A delayed and expanded sweep allowed viewing of the pulse following that triggering the sweep. Because alternate sweeps were triggered by pulses derived from oppositely directed inversion of the monostable circuit, unequal time intervals resulted in resolved pulses when observed in this manner. Adjustment of the time constant for recovery of the monostable circuit allowed superposition of the triggers and thus equalization of the time intervals.

The sine wave from the Hewlett-Packard 200CD oscillator operated at 73 cps was applied to the transducer through a step-up transformer. The phase of the gate pulses was set with the aid of another oscilloscope display. The vertical deflection of this oscilloscope corresponded to the sine wave and the horizontal deflection to the pulse from the GR pulse generator. That pulse was set to occur about 1 msec after the trigger pulse by use of the delay circuits in the pulse generator. This allowed the square wave produced by the monostable circuit to be used also as the drive to the electronic switches, since the reversals occurred outside the gate pulses that activated the counting circuits. Then the phase shifter was so set that the pulse occurring during the upward sweep of the oscilloscope was exactly super-

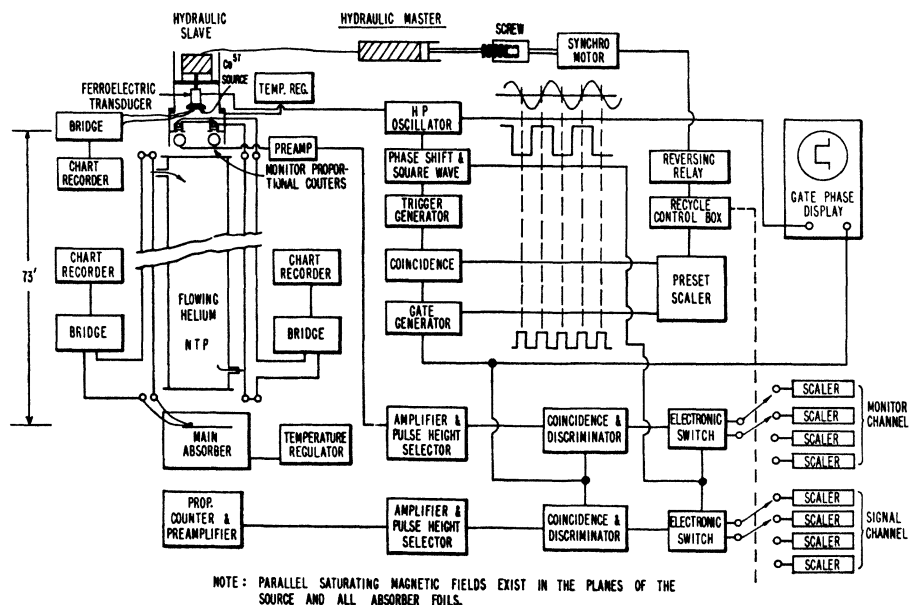

FIG. 3. A block diagram of the over-all system.

posed on that during the downward sweep. The accuracy of the overlap was also a reasonable measure of the mean symmetry of the waveform of the sine wave during the gate pulses.

The gating circuits themselves, for the main and monitor channels, were identical. The pulses from the single-channel analyzer in each channel were fed into a coincidence circuit together with the pulse from the GR pulser. The output of the coincidence circuit was fed through a Schmitt discriminator and the output of this in turn was applied to two coincidence circuits. Each of these was also supplied with a square wave synchronous with the sinusoidal modulation, one in each of the two polarities. These coincidence circuits provided the electronic switching. Thus the gated pulses from each, when phased properly, corresponded to oppositely directed velocities at the source transducer. The possibility exists that a small difference in dead time in the counters driven by the two sides of this circuit could lead to a spurious unbalance of the counts recorded on the two sides. To avoid this, pains were taken to make the dead time in the discriminator circuit preceding the switch longer than any later dead time. This was achieved by so connecting diodes to the capacitively coupled grid circuit that each pulse was followed by a long negative overshoot. A second pulse occurring before this bias-level overshoot had decayed could not reach the discriminator level. In this way a minimum time of about 3  $\mu$ sec was obtained between pulses and with scalers capable of 1-Mc/sec counting rates, no pulses should have been missed in the counters.

This aspect of the electronics was subjected to repeated tests. Using regular pulses from a pulse generator, at rates up to 50 kc/sec, it was possible to examine the equality of the live time in the two counters corresponding to the two sides of a given channel. It was found that, with the symmetry of the trigger pulses set in accord with the criterion of superposition on the oscilloscope display, an inequality of about one part in  $10^6$  existed in the two times. The inequalities in the main and monitor channels were not identical, but changes in the trigger settings did change them by the same amounts. The inequalities were of a scale less than 0.25% of the asymmetry change expected due to gravity, on inversion. The stability and reproducibility of these inequalities were adequate to eliminate any significant contribution to systematic errors.

That the dead-time situation was satisfactory was determined by operating both scalers of one channel from one side of the electronic switch, using random pulses at a very high counting rate near  $5 \times 10^4$  per second which could be produced in the monitor channel with the pulse height analyzer running in the integral setting. The two scalers yielded numbers agreeing to within one count in  $10^7$  or more. Tests of the performance of the switching between sides with random pulse timing could only be carried out to limits set by statistics since the two sides counted independent

samples. Little information on the performance of the system could be obtained in moderate times from such operation so the results with regularly spaced pulses were more informative on that point.

Automatic alternation between oppositely directed values of the calibration velocity  $V_J$  was provided. The gate pulses were counted by a preset scaler. When the preset number, usually 44 002, was reached, the scaler interrupted the trigger pulses to the gate pulse generator and stopped the motor producing  $V_J$ . At the same time a pulse actuated a ratchet relay so as to reverse the motor that provided  $V_J$  and also to change over the output data to another set of four glow-transfer counters, which recorded counts after two decades of scaling ahead of the switches. After a 5-sec delay the motor was started. A time delay of about 25 sec allowed the backlash to be removed from the mechanical and hydraulic system. At the end of this time, the preset scaler was automatically reset to zero and another 44 002 triggers counted, and the cycle continued in this manner. The use of an even integral number of gate pulses to determine the period for a given sign of  $V_J$  avoided breaking into a gate pulse and any inequality of the number of pulses contributing to the two sides of a given channel.

To allow study of the data accumulated in a given run, typically overnight, in a piecemeal manner, a photographic record was made during all runs. A ratchet relay and several time-delay relays made it possible to photograph automatically the eight six-digit glow-transfer counters and the preset scaler after every three, six, or twelve full periods of the cycling of  $V_J$ , corresponding to about 0.5-, 1-, or 2-h intervals. This record was particularly useful when a gross failure occurred in the system. Sometimes it enabled the salvage of some of the data prior to a failure.

The pulses fed into the gating system were produced in the single-channel pulse-height analyzers of a Hamner 302 linear amplifier on the main channel and of a Hamner 328 plus 361 preamplifier in the monitor channel. The pulse rate in the monitor channel was nominally four times greater than that in the main channel and was limited mainly by electronic considerations rather than by solid angle in the detectors.

There were two identical detectors for the main channel, one mounted permanently at each end of the path. Each was a proportional counter in the form of a 17-in.  $\times$  17-in.  $\times$  36-in. copper box with a 3-mil tungsten wire stretched along the long axis through Stupakoff seals used as guard rings. A 16-in. diam side window was covered with 1-mil Al foil inside a sheet of Mylar for strength. A preamplifier and cathode follower circuit were attached to one end of the box along with a pressure gauge. The counters operated with a 90% Ar-10% CH<sub>4</sub> mixture at several ounces above atmospheric pressure, with about +3600 V on the central wire. At intervals of a few months the counters were flushed with fresh gas and then closed off again, but in general this



procedure made little apparent change in the detected spectrum. The counters were not rigid enough to allow evacuation so gas purity could only be obtained by sufficient flushing.

These counters were an improvement over the set of scintillation counters previously used since their efficiency for detecting the 123-keV line accompanying the 14-keV line was considerably smaller. The ratio of the integral counting rate above the baseline to that in the 5-to-9-V window typically used for the 14-keV  $\gamma$  ray was only about 1.5 to 1 for these counters. The net background within the window due to the 123-keV  $\gamma$  ray and impurities was about 30% of the net total counting rate with the absorbers in place. The resolution of the counters was not very much better than that of the scintillation counters formerly employed. Furthermore, the resolution degraded significantly at high counting rates, and the gain decreased with increased counting rate. The elimination of the dependence of the relative weights of various parts of the absorber on the relative gains of the several multipliers used in the earlier experiment was considered to represent an important operational improvement in addition to the improvement from fuller utilization of the solid angle available in the system.

The design of an oven suitable for the main absorber and capable of maintaining a constant temperature distribution, preferably a uniform one, was complicated by the necessity of maintaining a low absorption of the  $\gamma$ -ray beam over the whole area. With the exception of beryllium, no metal of sufficient thickness to provide significant thermal conductivity could be used to complete the enclosure across the ends. Figure 4 is a cross-sectional drawing of the unit finally evolved. The absorber was a mosaic of foils each about 2 in. square cemented to a Mylar sheet of thickness 0.007 in. to cover the area of a circle of diameter 15 in. This sheet in turn was cemented to one face of an aluminum honeycomb support (Hexcel) 1 in. thick with hexagonal cells of diameter  $\frac{3}{4}$  in. The honeycomb cells were made of aluminum 0.003 in. thick. The purpose of the Hexcel was to provide both stiffening and transverse thermal conductivity with a minimum obstruction to the  $\gamma$ -ray beam. The support structure was found in practice to attenuate the beam by about 5%.

This structure carrying the absorber was mounted across the central plane of an aluminum pipe of  $\frac{1}{8}$ -in. wall thickness and 24 in. length. The center 8 in. length of the pipe was separated from the end sections by 0.007-in. Mylar windows held with C-ring seals between flanges. The air pressure in this central section was reduced to a few microns by a mechanical pump connected to a pumping line which was then closed off and disconnected. In this way response by the absorber to airborne sound was very greatly reduced. That this was so was confirmed by tests with a vibration pickup mounted on the absorber surface. On the other hand the

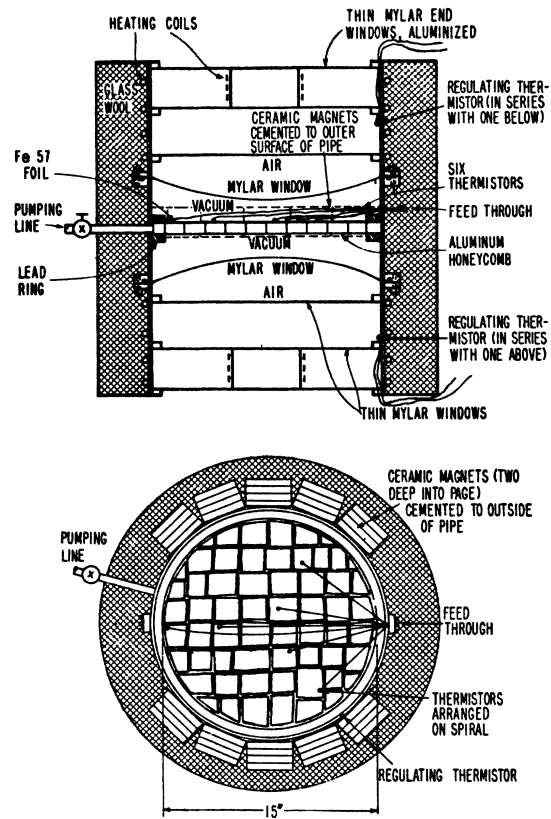

FIG. 4. The evacuated, regulated oven for the main absorber. The heating coils in the end spaces actually were wound with thin strips.

absence of air increased the thermal inhomogeneity across the foil.

The air spaces inside the pipe above and below the evacuated region were broken into three sections by thin Mylar diaphragms. The end ones of these were aluminized. Coils around the outside of the pipe provided heat and two thermistors connected in series, one mounted inside each end section, served as a reference for a Sargent Thermonitor control unit which supplied the current to the heating coils. A magnetic field to polarize the iron, everywhere greater than 50 Oe in the plane of the absorber and reasonably uniformly directed over the sheet, was provided by two banks of ceramic permanent magnets, one bank cemented to each of opposite sides of the pipe. Some evidence was obtained in the course of experiments leading to this final design that vibrations induced when the ac heater currents were used could cause difficulties. For that reason the power controlled by the Sargent Thermonitor units was rectified and smoothed by a transistor regulator.

Six  $\frac{1}{4}\%$  precision thermistors (Fenwal Iso-Curve glass probe thermistors, nominally 2000  $\Omega$  at 25°C) were cemented to the absorber surface at various azimuths and radii to allow sampling of the temperature distribution. Leads from these were brought through a multi-



lead seal on one side of the pipe. Experiments with the distribution and the regulation against ambient changes when the absorber was held at about 45°C evolved the final system of heating. The heating current was passed also through additional end coils of aluminum strip wound on Mylar rings about 4 in. in diameter held between the two outermost diaphragms at each end of the pipe. The resistance of these coils, which determined the power in them relative to the power supplied to the coils on the pipe, was selected by experiment to provide a reasonably flat temperature distribution over the absorber. During operation the temperature of the absorber, in the form of the unbalance of a Wheatstone bridge set to the desired nominal resistance, was continuously recorded. Only one of the measuring thermistors was used, usually that one about midway between the center and the edge of the foil. A Brown strip chart recorder with a Honeywell 2HLA-7 preamplifier gave a full scale sensitivity of about 2°C. The time-averaged temperature for a given run could be estimated to within less than 5 mdeg. The same leads from the

bridge circuit and recorder were used for all locations of the absorber unit. These leads, consisting of a shielded pair, ran the full height of the tower with shorting plugs providing continuity at all sites except that in use. Thus the same net lead resistance and background ac pickup were always present. A similar arrangement was used to record temperatures for the monitor absorbers and for the source.

The source and the monitor elements were put into an integrated unit of which Fig. 5 is a cross-sectional drawing. The two parts were connected by a Lucite ring so that the temperatures could be made different by adjustment of the relative power in the separate heating coils, both supplied from a single Sargent Thermomonitor unit with rectified output. The reference of the regulator was a thermistor mounted near the monitor heating coils.

The 4-in.-diam source disk was cemented to a 4½-in.-diam copper disk ½ in. thick, and this was provided with braces of ⅛-in.-thick copper for stiffening and mechanically coupling the disk to the 1½-in.-diam, 2½-in.-long and ⅜-in.-wall cylindrical barium titanate transducer. At 73 cps, about 30 V rms across the thickness of this transducer provided the velocity modulation to the regions of maximum slope in the absorption line. The transducer in turn was mounted on a heavy brass base which was fastened to the piston of a 1½-in.-diam hydraulic cylinder, to provide the calibrating motion. This was driven by a ¾-in.-diam master cylinder moved by a 1.5 rpm synchronous motor rotating a ½×20 nut on a screw. A precision thermistor at the center of the source disk provided for temperature monitoring. The outside of the source oven was wrapped with a 1-mm thickness of lead to reduce the level of external radiation. Permanent magnets were cemented to the outside of the assembly to provide a transverse field in the plane of the source of about 100 Oe.

The monitor part of the assembly was designed around a pair of Reuter-Stokes proportional counters. Each was provided with a monitor absorber foil of 43.5% Fe<sup>57</sup> and 1.8 mg/cm<sup>2</sup> iron cemented to a beryllium sheet about 0.030 in. thick. These absorbers were fastened over holes in a copper plate on opposite sides of the beam of radiation along a diameter perpendicular to the magnetic field at the source. A magnetic field parallel to that in the source was provided in the plane of the absorbers by magnets cemented to the copper mounting plate. The proportional counters were wrapped in lead and considerable lead screening was provided to limit the radiation into the proportional counters to that passing through about ½-in.-diam circles of the absorbers. The actual monitor aperture was limited at the counter windows to give as closely as possible uniform weight to all parts of the source in each counter. The first tubes tried were filled with a 90% krypton-10% methane mixture and became useless in about 24 h of running in the intense radiation near

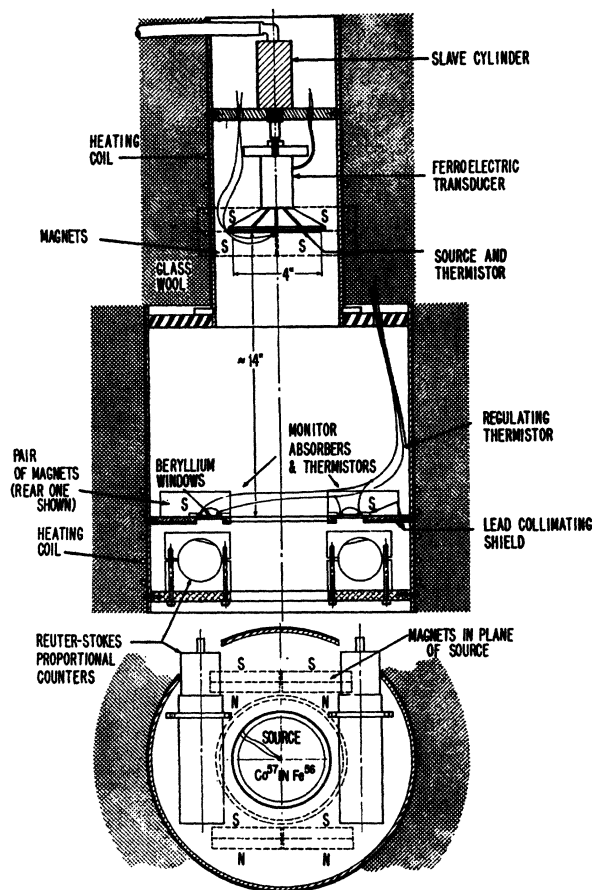

FIG. 5. The oven containing both the source and its ferroelectric transducer and hydraulic cylinder as well as the monitor absorbers and their associated proportional counters. A yoke and set of coil springs that kept the hydraulic cylinder under pressure have been omitted to avoid complication.

the source. Later tubes were filled with 90% krypton-10% nitrogen. An improvement in the lead shielding and reduction in the operating voltage from 2300 to 1900, made possible by increased preamplifier gain, may have been the main cause of the improved life. The pulse-height spectra from the two counters were made equal by adjustments of apertures and of supply voltage. The krypton-nitrogen-filled counters seemed to degrade quickly after about three months of operation. The gain fell off and the spectrum broadened. Two replacements were installed in the interest of maintaining symmetry in the course of the experiment.

The monitor temperature was sampled by a set of four precision thermistors, two on each absorber, connected in series-parallel to give a nominal resistance equal to that of a single thermistor unit. The resistance of the combination was believed to represent well an appropriately weighted average. The monitor temperature proved to be very stable, hardly ever changing by more than 0.010 deg, once the regulator was set for a given run.

At the high counting rates in the proportional counters of the monitor, the dependence of the counter gain on intensity gave rise to an anomalous dependence of sensitivity on setting of the window of the pulse-height analyzer. The variations of counting rate accompanying the sinusoidal modulation correlated with a variation of position of the pulse height spectrum. Selection of only the low-half of the spectrum resulted in almost the full available change of counting rate for a given change of source velocity. The statistical standard deviation was only that of half the counts. In effect, the counts in the upper-half of the pulse-height distribution were unaffected by velocity and conveyed no information on source velocity. This phenomenon was discovered when short runs were made with different pulse-height-analyzer settings in search of optimum sensitivity. The behavior was as if there were radiation on the high side of the spectrum not participating in the resonance, but the correct explanation was confirmed by observing the pulse-height distributions in coincidence with a short gate pulse, as a function of the position of the gate pulse in the velocity-wave form. The result was that the changes in intensity accompanying the varying absorption produced spectra having identical counting rates on the high-voltage sides but differing on the low sides, as sketched in Fig. 6. Although improved statistics were available through this effect, it was not used for fear that the exact information sought from the monitor channel could be degraded. In particular, if the gain of the proportional counters had a lag not negligible compared to the duration of the gate pulse, as might be expected if the effect results from a charge plasma sustained in the counter, a distortion in the effective gating function would be introduced. To avoid complications of such origin, the window in the monitor channel was set to accept the full pulse-height peak.

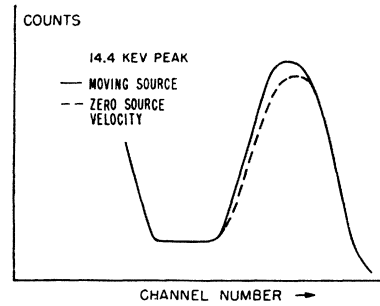

FIG. 6. Curves representing pulse-height distributions from the proportional counters in the monitor channel at two source velocities. The lower peak counting rate at the null point in the velocity waveform of the source correlates with a larger gain in the counter. The two curves overlap on the high-voltage side and thus an artificially large variation of counting rate with source velocity results in the lower voltage channels.

### SYSTEM OPERATION

The data taken with the apparatus in its fully evolved form was composed typically of overnight runs and full time runs over weekends. Severe vibrations induced by the nearby helium liquefier made weekday runs untrustworthy. For each run 11 numbers were obtained. Four of these corresponded to counts at the four combinations of the source velocities  $\pm V_M$  and  $\pm V_J$  for the main channel and four more for the monitor channel. The other three numbers corresponded to the averaged deflections of the recorded traces for the measuring thermistor bridges connected to the source, the monitor absorber and the main absorber, respectively. Following the reasoning above, the four counts for a given channel were used to calculate, from the measured value for  $V_J$ , the effective asymmetry of the absorption line, with its statistical standard deviation, for the main channel and for the monitor channel. Each of these was then corrected to a fixed thermistor resistance of both the source and the respective absorber. One complication involved the fact that the monitor observed the source at a slant angle. Doppler effects due to motion along the main axis of the system were reduced by the cosine of the slant angle to the monitor. Thermal shifts were, of course, absolute and independent of the angle of view. In an earlier form no provision for accurate recording of the source temperature was provided on the grounds that changes of source temperature affected the main absorber and the monitor asymmetries equally and so cancelled from their difference. On the other hand variations of transducer wave form would affect only the velocity along the axis of the system and their effects at the monitor absorber would be reduced by the same slant projection as was the effect of the calibration velocity  $V_J$ . Since a crucial function of the monitor was to correct for variations of transducer wave form, particularly any that might correlate with inversion, recording of source temperature was added and correction of asymmetries to a standard source temperature was

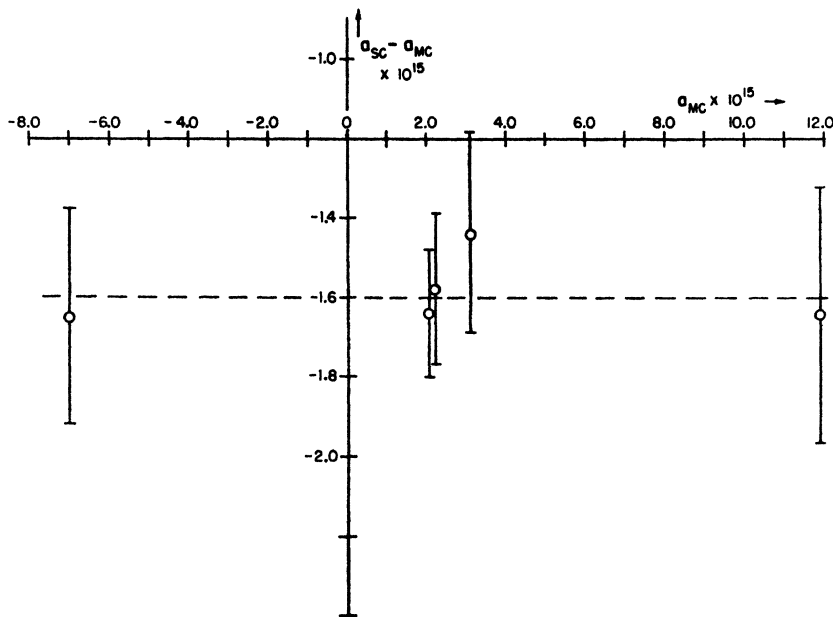

FIG. 7. The difference between the temperature-corrected asymmetry of the main channel  $a_{sc}$  and that of the monitor channel  $a_{mc}$  as a function of  $a_{mc}$ . These large magnitudes of  $a_{mc}$  were introduced by electronic distortion of the waveform applied to the source transducer.

included in the data reduction. In this process the effective temperature coefficients in the monitor channel, used to correct for temperature variations of the monitor absorber and the source, were increased by the factor  $[\cos\theta]^{-1}$ , where  $\theta$  is the suitably weighted mean slant angle of view.

To check whether the monitor and main channels did, in fact, respond similarly to variations in wave form of the source modulation, some data on the relative asymmetries were run with large distortions introduced electronically. This test was one run with an earlier form of source mounting and only a single, separately mounted monitor unit, in the course of efforts to discover sources of instability and error. The result of this test is shown in Fig. 7, where the monitor asymmetry, which is itself a measure of the wave form distortion introduced, is plotted as abscissa and the difference between the main and monitor asymmetries as ordinate. The total range of about  $20 \times 10^{-15}$  of the abscissa is perhaps 40 times greater than the fluctuations in monitor asymmetry that occurred spontaneously in operation due to variations of wave form, and it therefore appears as if the monitor was adequately performing the function intended. It may be noted that this result was true in spite of an inadequate rigidity in that earlier form of source mounting. The changes of wave form apparently did not change the relative importance of transverse velocities and in that sense the test failed to throw light on that inadequacy of the source and single monitor design. That inadequacy was overcome in the final design by the rigid source mounting and dual monitor channel, however.

The actual data runs were made in the period from mid-March through September, 1964. For the first four

months the full tower height was used as a baseline. The source-monitor unit and the main absorber unit were interchanged between the top and the bottom approximately once a week. Usually, this was done in the morning of a weekday which could not be used for data collection because of vibrations. The rest of the day was then used to bring the oven temperature back to equilibrium after the disturbances associated with the interchange. The time constant for thermal equilibrium of the source was several hours, whereas that of the monitor in the same unit was less than an hour. The main absorber required two or three hours to stabilize. A run was started as soon as possible after the helium liquefier was shut down at about 6 p.m. and the apparatus was stopped before the liquefier was started between 8 and 9 a.m. the following day. On days the liquefier was not run, a daytime run was also made. Between Fridays and Mondays runs of a full 24 or 36 h duration were often made. For each run a value was computed for the difference between the apparent asymmetry of the main channel and the monitor channel after temperature corrections, according to the discussion given above. The difference between this quantity for the source at the top and the same quantity with source at the bottom was evaluated usually from the weighted mean of points taken with the source at one end both before and after a set of runs at the other. It was supposed that the effect of any steadily drifting parameters of the system would be compensated by this interpolation of the measurements to a common time for both directions. No evidence was produced that such a drift was present. Altogether, seven values for the gravitational effect over the full path available were obtained. These results, divided by the expected value

FIG. 8. The final data. The vertical bars indicate statistical standard deviations and the horizontal bars the period of time covered by data contributing to a given point.

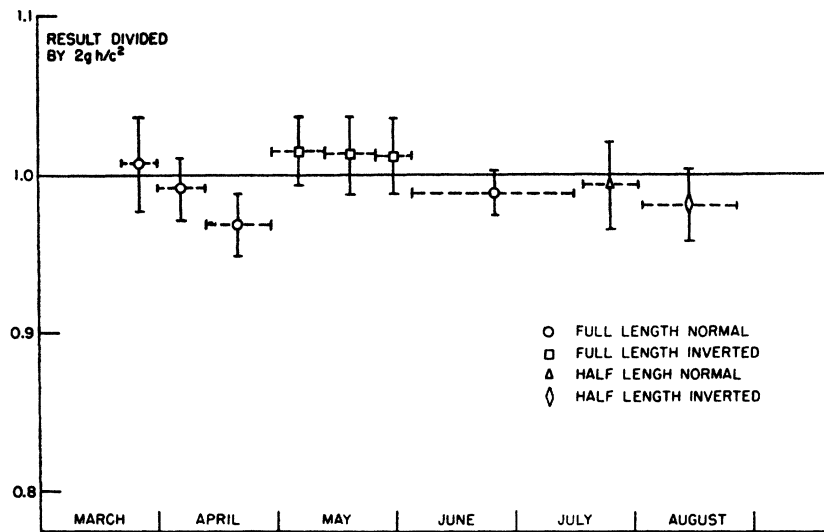

$2gh/c^2$  equal to  $4.905 \times 10^{-15}$ , are plotted in Fig. 8, with horizontal bars spanning the time interval involved and vertical bars indicating the relevant statistical standard deviation.

The data of these first seven runs of Fig. 8 are further divided into two classes by the use of circles and squares enclosing the data points. In order to maintain the geometry of the beam traversing the main absorber closely identical for the two directions of operation, the absorber unit itself should be inverted with the system as a whole. A more serious perturbation would then be introduced, however, because the temperature-regulating oven could not be relied upon to produce exactly the same distribution of temperature. Among the reasons was the fact that the Hexcel supporting structure was on one side of the absorber foil and represented a basic asymmetry. The same Hexcel could have led to different situations for beams traversing the absorber in opposing senses, because the shadow of the Hexcel fell slightly differently on the foil in the two situations. To allow for such differences, the absorber was operated at both ends with the same side up, which we called right side up, and a result derived. The first three and the seventh point indicated by circles correspond to this. The mean of these could include a systematic error due to the opposite traversals of the absorber by the beam with the source at opposite ends. On the other hand, little change in temperature distribution should be involved. The fourth through the sixth points utilized the absorber inverted from the position in the other data. Any error due to the opposite traversals by the beam should apply in the reverse sense in these data. The weighted mean in the first orientation was  $0.986 \pm 0.010$  and that in the inverted was  $1.013 \pm 0.013$  so there is little evidence of a systematic effect. Nevertheless, it is consistent with the philosophy that it could exist, to use as a final result an arithmetic mean of these

two rather than a weighted mean. With that interpretation, the result of the experiments on the full two-way baseline  $2h$  of 44.96 m is  $0.9994 \pm 0.0084$  times the value of  $2gh/c^2$ .

The remaining two points plotted on Fig. 8 are the results of runs made using only the lower-half, approximately, of the baseline. For these runs the upper proportional counter was mounted near the top of the shortened path. Thus, the shorter path utilized the entire absorber area with a correspondingly increased solid angle. Data were taken again with the main absorber the same way up at each end and then inverted at each end. One point is plotted for each orientation and again an arithmetic mean should be taken. This leads to the result of  $0.986 \pm 0.018$  times the value of  $2.226 \times 10^{-15}$  expected for this round-trip path length.

Assuming these net results for the two lengths are independent measurements of a single parameter, the weighted mean is  $0.9970 \pm 0.0076$  times the result expected. In all of the above results the statistical standard deviations derived from the numbers of counts involved are given. Evidence on the apparent stability of the apparatus during the recording of these data can be sought by comparing the rms deviations of points from the measured mean value of an asymmetry difference with the statistical standard deviations for the same set of points as derived from Eq. (7). The value of the ratio of the rms deviations to the statistical standard deviation should be close to unity when averaged over a large number of points. For the full-length runs treated on a day-to-day basis, this ratio was 1.13 for 37 points with the absorber right side up and at the top; it was 0.85 for 20 points with the absorber inverted and at the top; the ratio was 0.95 for 38 points with the absorber down and right side up, and also 0.95 for 18 points with the absorber down and inverted. There remains the question of systematic errors.

### SYSTEMATIC ERROR

For one thing, the velocity of the hydraulic cylinder that provided the basic calibration had a limited precision and reliability. Over the course of the experiment, measurement of that velocity was carried out on a number of separate occasions. In most of these an American Optical Co. reticule was attached to the moving system and observed with a microscope. The time taken to move 1.5 mm was measured repeatedly as the system cycled back and forth in the normal way. In the final measurements, a Starrett dial indicator gauge was used to observe the motion and again the time to move a fixed distance measured. The results obtained with both methods were consistent. The hydraulic pistons themselves were operated under a continuous positive hydraulic pressure provided by a set of three compressed coil springs included in the structure attached to the transducer base plate. By this means the single seal of the slave cylinder was under continuous pressure irrespective of the direction of motion. So long as the motion remained within the available stroke of the slave cylinder, no air dilution was encountered, but there was a slow loss of fluid past the seals, leading to a slow creep in the mean position of the slave piston. This creep amounted to about 1 mm per day and of course contributed to measured asymmetries, but its effect cancelled out of the result because of the use of the monitor channel. In fact, since there was evidence that the creep did not depend upon whether the cylinder was pointed upward or downward, the inversion of the system itself would have compensated for it, even in the absence of a monitor. The main complication that arose because of the slow leakage, beyond the need to replenish the fluid in the system about every four days to avoid coming to the end of the stroke, was in the measurement of the average speed of the calibrating motion. A small difference of about 2% was noted for the two directions, consistent with the slow leakage of fluid. The true piston speed was, of course, the average between these.

Measurements of the speed were made on about six separate occasions spread over the period of the taking of data. Altogether about 100 time measurements were made. The mean result was a value for  $V_J/c$  entering Eq. (4) of  $(2.611 \pm 0.005) \times 10^{-14}$ . The uncertainty of about 0.2% overlaps the means of the five separate groups of measurements and represents a reasonable estimate of the limit of systematic uncertainty contributed to the final result from this source.

The temperature corrections used represented another possible source of error. After completion of the main runs a direct evaluation of the temperature coefficient was undertaken by making runs with the absorber both ways up and operated about 5°C above and 5°C below the usual 43.5°C nominal temperature maintained throughout the main experiment. This had the advantage of relating directly to the foils used as absorbers

and any errors in the calibration of the temperature measuring instruments cancel when the coefficient is applied to our own data. Such errors do, of course, contribute to the absolute coefficient resulting. Our result for the fractional change of frequency per degree Centigrade was  $-(2.12 \pm 0.02) \times 10^{-15}$  and is consistent with earlier values.<sup>15,18</sup>

In order to know the contribution to the over-all uncertainty from the limited precision of our knowledge of the temperature coefficient, the weighted mean correction applied for each channel was computed for the full and for the half-length runs. The net contribution of temperature corrections to the full-length runs amounted to about 3% of the gravitational effect. Thus the residual uncertainty in the coefficient makes a negligible contribution to the uncertainty in the result. On the half-length experiment the net temperature correction was only 2% of the smaller effect. Thus, even less uncertainty is contributed to the over-all result from this cause.

The greatest uncertainty is believed to reside in the limited accuracy with which the thermistor used to monitor the temperature of the main absorber represented the correct average over the whole foil area. As operated, the net deviation of that temperature was small, as reflected in the 3% contribution to the over-all result, but the detailed shape of the temperature distribution was known to change with ambient temperature. Any systematic difference in the ambient temperatures at the two ends of the system averaged over the times when the main absorber was located there would be reflected as an error in the over-all result.

The direct measurement of the change in temperature distribution with ambient temperature was attempted at several times, but it was difficult to provide a large change in ambient and at the same time establish essentially equilibrium conditions. Instead the six precision thermistors were observed with a normal ambient temperature but with the oven maintained at about 38°C and about 48°C instead of the usual 43.5°C. It was then assumed that the distribution was a function only of the amount above ambient sustained by the oven. Accordingly the distribution at 38°C in the oven should resemble that for an ambient about 5°C above normal and that at 48°C should resemble the distribution for an ambient temperature less than normal.

The resistances of the six thermistors for the two oven temperatures are listed in Table I both for the absorber oven standing right-side up and for the oven inverted. The increase of resistance of each thermistor for the approximately 10-deg reduction of oven temperature is shown in the fourth line. Since the thermistors themselves are known to fall within  $\frac{1}{4}\%$  of a given resistance at a standard temperature, no absolute evaluation of the temperature homogeneity could be made without further calibration of the thermistor involved. The changes, however, differed in a range over 1% and were assumed to correspond to changes in

TABLE I. Resistances of the six thermistors at oven temperatures nominally 5 deg below and above normal.

Thermistor	1	2	3	4	5	6
	Right side up					
Ohms at 38°C	1214.9	1216.0	1218.4	1216.5	1217.7	1219.6
Ohms at 48°C	842.8	840.8	842.8	840.6	839.0	840.5
Ohms rise	372.1	375.2	375.6	375.9	378.7	379.1
Relative to No. 3	-3.6	-0.4	...	+0.3	+3.1	+3.5
× weight	-3.6	-0.8	...	+1.2	+15.5	+21.0
Net weighted shift/10°C	~+1.5 Ω					
	Inverted					
Ohms at 38°C	1227.3	1227.2	1228.8	1223.6	1223.6	1224.6
Ohms at 48°C	848.2	849.8	849.7	845.1	843.7	848.8
Ohms rise	379.1	378.4	379.1	378.5	379.9	375.8
Relative to No. 3	0.0	-0.7	...	-0.6	+0.8	-3.3
× weight	0	-1.4	...	-2.4	+4.0	-19.8
Net weighted shift/10°C	~-1.0 Ω					

distribution. Line five in the table represents the difference between the change in a given thermistor and that of the third thermistor, the resistance of which was used for temperature corrections throughout the experiment. Assuming cylindrical symmetry, each thermistor represented an area proportional to its distance from the center of the absorber foil. That distance was proportional to the number of the thermistor, so the sixth line lists the weighted difference for each thermistor, and finally, a value for the weighted average shift compared to the shift sensed at thermistor three is found. For the full 10-deg change in ambient, a discrepancy of +1.5 Ω for right-side up and -1.0 Ω for inverted absorber are found.

No continuous record was kept of the ambient temperature. The room at the bottom of the tower was, however, very stable thermally at about 23°C, having originally been intended to serve as a constant-temperature room. The penthouse used at the top did vary widely in temperature. Over the period involved, it ranged between about 16 and 30°C. It seems doubtful, however, that the difference in ambient temperature between top and bottom averaged over the run could have been as large as ±3°C. Since the slope at 1000 Ω is about 35 Ω per degree, such a difference in ambient temperature would lead to a temperature uncertainty over the absorber of about ±12 mdeg. From this and the above temperature coefficient, a net systematic uncertainty of ±0.005 times the gravitational effect is introduced. An argument for a reduction of this estimate by a factor of about 3 could be based on the fact that the difference between the weighted mean of the six thermistor resistances and that of number three reversed sign upon inversion of the absorber oven. The fact that the over-all results were obtained as an average for these two orientations means that this source of error should cancel from the result to the degree that the corrections are equal and opposite. In spite of this, we

retain the uncertainty as the major contribution because it is difficult to know how exactly the measured weighted mean represents the true value appropriate to the experiment.

In Eq. (10), a modification is given to the result of the measurement of the line asymmetry from the inclusion of higher order terms in the Taylor expansion, assuming a Lorentzian shape. All values quoted so far have been obtained using only Eq. (5), which assumes the system to be linear. It is difficult to evaluate the applicability of a correction like that of Eq. (10). For one thing, the resonance line was deep enough to involve some saturation in its center, which would tend to change the shape away from Lorentzian. It also appeared to be at least 1.5 times as broad as would be attributed to the lifetime limit. Finally, the fact that the modulation was actually about a quarter cycle of a sine wave of velocity rather than a constant velocity has the effect of modifying the line shape. The factor of Eq. (10) assumes the modulation to be set to correspond to  $V_M^2 = V_H^2/3$ . In practice the modulation amplitude was chosen by experimentally minimizing  $S$ , and at that setting the transmission averaged over the quarter cycle of sine wave was increased about 10% above that at no modulation. For a Lorentzian line, the coefficient of the correction term in an expression like that in Eq. (10) but carrying  $V_M$  as a parameter drops to zero at  $V_M^2 = V_H^2$ , which also corresponds to operation at the half-value point in the absorption curve. The point  $V_M^2 = \frac{1}{3}V_H^2$  corresponds to operation at  $\frac{3}{4}$  of maximum absorption in a Lorentzian line, but the line was less than 40% deep. It is thus indicated that our usual operating point, averaged over the actual waveform during the period of the gate, is between the point  $V_M^2 = V_H^2/3$  and  $V_M^2 = V_H^2$ , and thus an averaged correction factor would fall between  $1 + \frac{3}{2}(V_J/V_H)^2$  and 1. For our values  $V_J = 7.83 \times 10^{-4}$  cm/sec and  $V_H \approx 1.5 \times 10^{-2}$  cm/sec,  $(V_J/V_H)^2 \approx 2.7 \times 10^{-3}$ . Accordingly, it seems reasonable to make as a correction to all values an increase by 0.002 and to include a systematic uncertainty of ±0.002 to cover the range between no correction and the full correction that would apply if operation had been at the point of maximum slope on a Lorentzian line. The correction for nonlinearity and a systematic uncertainty relating to it were not included in the original brief publication of these results.<sup>19</sup>

The height of the path was measured several times with a steel tape and is believed known to one in 2000. Uncertainties in  $g$  and  $c$ , using standard tabulated values, are negligible.

Cne is led then to the final result, including the full-length and half-length runs weighted according to the inverse square of their statistical standard deviations,

$$\Delta V/c = (0.9990 \pm 0.0076) 2 gh/c^2$$

<sup>19</sup> R. V. Pound and J. L. Snider, Phys. Rev. Letters 13, 539 (1964).

TABLE II. A list of estimated limits of contributions to systematic error.

Origin	Amount
Path length	$\pm 0.0005$
Temperature coefficient	$\pm 0.0005$
Temperature distribution	$\pm 0.0050$
Velocity calibration	$\pm 0.0020$
Nonlinearity	$\pm 0.0020$
Simple sum	$\pm 0.0100$

where the range indicated is the over-all statistical standard deviation but does not include the systematic uncertainties. In addition, the central value may range over  $\pm 0.010$  as our estimated limit to the systematic errors, all simply added arithmetically. The several contributions to this are listed in Table II.

If one were to follow the frequent practice of treating such uncertainties as independent and of random sign, an rms value of  $\pm 0.006$  would result, and taking the rms value of this and the statistical standard deviation yields an overall uncertainty of  $\pm 0.0095$ . It seems fair to describe the present result as confirming the prediction based on the principle of equivalence to a precision of about 1%.

The approximately 1% limit of error in this over-all result represents a fractional frequency change of  $5 \times 10^{-17}$ , or a claimed precision of  $5 \times 10^{-5}$  times the basic resonance linewidth. Such a fine-scaled "splitting" of the line was made possible by the fact that inversion allowed separation of the effect sought from inherent shifts. Furthermore, the use of the monitor channel eliminated the effects of variations of transducer waveform. Such variations, without a monitor, play a role analogous to cavity pulling in a maser oscillator or background effects in a densitometer analysis of a spectral line.

There might be some interest in a "one-way" result, that is a measurement that would be sensitive to a shift dependent on height or distance but not reversing sign with inversion, which would then cancel out of the "two-way" measurement. Unfortunately, in a one-way experiment one has no independent test for the shifts that might accompany the necessary geometrical changes involved.

The data of greatest reliability bearing on this question come from combining the results of the final apparatus, using the full length, with those for half the length of the path, with the source kept at a given end. For the experiments over half the path, the detector was moved with the absorber, so essentially the whole area of the absorber was in use. Even so the geometry was necessarily different for the two situations. For example, the Hexcel support, with the larger spreading angles in the shorter runs, shadows a different part of the absorber, than in the full-length run. A change in the effect of any inhomogeneities in the absorber is

therefore introduced. The experiments were not carried out with such a comparison in mind, so there were long separations in time between the recording of some of the data involved. Nevertheless if one looks at the change in the net asymmetry difference between the main and monitor channels, when the absorber was moved from the middle of the tower to the top, keeping the source at the bottom, the result was about 0.87 times the  $1.338 \times 10^{-15}$  expected value of  $gh/c^2$ , corresponding to the part of the tower added on a one-way basis. Similarly, when comparing data with the beam going downward, a result about 1.15 times the same expected value was found, corresponding to moving the source from the top to the center of the tower, with the absorber at the bottom. In each case statistical standard deviations were about  $\pm 0.06$ . These results indicate a frequency increase of about  $2 \times 10^{-16}$  associated with this lengthening of the path. This may have resulted from the changed geometry. A change of about  $0.1^\circ\text{C}$  in the weighted mean temperature would be necessary to produce such a shift, and that was quite a large part of the total range of temperatures indicated by the six thermistors. Some consideration is being given to experiments over longer baselines to check further on this point.

With the completion of this phase of the experiment, one is led to wonder how it could be further improved. The role of thermal instability as the major source of systematic error could be very much reduced by provision of an environment itself stabilized thermally. Space in either a well-controlled building or an underground facility would go a long way toward eliminating this problem. Of course, a longer baseline would reduce the importance of a given absolute uncertainty in direct proportion to its total path.

The uncertainties of velocity calibration and of nonlinearity would not be affected by a moderate increase in baseline. Hydraulic pistons of much better quality could undoubtedly be found or made. With a longer baseline, however, the net shift begins to compare to the maximum usable calibration speed. Consequently it is attractive to incorporate a third velocity into the system. One could use a platform, for example, at the top of the system, continuously moving upward at a precisely known speed near  $gh/c$ , to compensate for the gravitational effect continuously. Such a velocity corresponds to about 1% of the path  $h$  in 3 days, so that system would need to be recycled frequently to prevent important geometrical changes. The velocity measurement on which the result would depend most would then be that of this compensating motion. The cycling motion  $V_J$  would be used only to measure any discrepancy between the shift and the compensation chosen. Correspondingly, the uncertainty due to nonlinearity would also enter only in this less important way.

To justify a renewed effort, one must, of course, reduce the statistical uncertainties accordingly. Using a



source strength renewed to our original 1.25 Ci and counting with our present absorber aperture, it would be difficult to obtain sufficient counts to reduce the statistical uncertainties below about 0.25%. Of course with a larger absorber one could gain accordingly in this area.

The possibility, *a priori*, of a discrepancy between the simple theory and experiment in the domain between a few tenths and one percent does not appear large. One aspect that may be worthy of mention is that  $g$  includes the effect due to the earth's rotation amounting to a reduction from the purely gravitational acceleration by about 0.3%. Agreement at that level would then compound the effects of gravitation and of central acceleration. These latter have, of course, been observed directly, in their own right, in experiments with rotating systems.<sup>20,21</sup>

The view that the local time scale depends on gravitational potential appears to require a coherent source for confirmation. The present experiment is unable to distinguish between frequency changes and velocity changes, for example. It appears as if an experimental

comparison of clocks at different potentials would make a useful complementary contribution to the over-all status of confirmation of theory.

#### ACKNOWLEDGMENTS

Many persons have contributed to the design and carrying through of this experiment. Dr. Glen A. Rebka, Jr., who collaborated with one of us in the original version, contributed through that work in a most fundamental way. We are indebted to Dr. R. W. P. Drever who, during a one-year residence here, designed and introduced our large proportional counters and contributed in many less concrete but important ways. The members of the shops and services in these laboratories, and particularly F. B. Robie as Engineer in the Department of Physics, have aided generously in many indispensable ways. Paul Horowitz rendered helpful and efficient aid during a couple of summers. Finally, Rufus Walker, Jr., and Jack T. Sanderson, at the time graduate students working on other projects, gave generous and valuable help on several occasions, in particular by designing a computing program.

Thanks are due to the U. S. Office of Naval Research for support through Contract No. Onr 1866(19) and to the Francis Barrett Daniels Memorial Fund which supported the purchase of some of the equipment.

---

<sup>20</sup> H. J. Hay, J. P. Schiffer, T. E. Cranshaw, and P. A. Egelstaff, *Phys. Rev. Letters* 4, 165 (1960).

<sup>21</sup> D. C. Champeney, G. R. Isaak, and A. M. Khan, *Nature* 198, 1186 (1963).

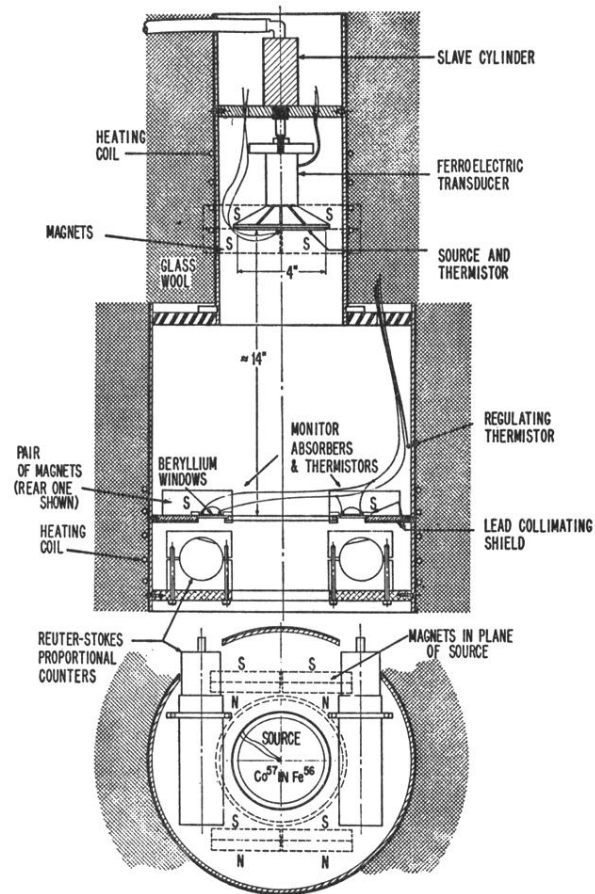

FIG. 5. The oven containing both the source and its ferroelectric transducer and hydraulic cylinder as well as the monitor absorbers and their associated proportional counters. A yoke and set of coil springs that kept the hydraulic cylinder under pressure have been omitted to avoid complication.