

## Translational Inertial Spin Effect with Photons

O. COSTA DE BEAUREGARD

*Institut Henri Poincaré, Paris, France*

(Received 12 March 1965)

The Borgnis technique is used to solve the Maxwell equations under the following conditions: (a) Complex field strengths are used such that  $\mathbf{H} = \pm i\mathbf{E}$ , that is, circularly polarized waves of positive or negative helicity; (b) there is only harmonic time dependence through a factor  $\exp(iWt)$ , that is, a pure energy state of the photons; (c) there is no  $z$  dependence, that is, no  $k_z$  component of the photons' momentum; (c) there is no restriction on the  $x, y$  dependence of the solutions. It is then shown that the  $S_z$  component of the Poynting vector obeys the formula

$$\pm 2WS_z = \partial_x S_y - \partial_y S_x$$

and is in general nonzero. This fact, together with the postulated nullity of  $k_z$ , is the expression of the "translational inertial spin effect." An experiment using the limiting case of total reflection is proposed to test the effect. A discussion of gauge-dependent expressions of the effect, using potentials, is also given, in connection with de Broglie's formulas for the current- and spin-density 4-vectors of the photon waves.

### I. INTRODUCTION

IN a preceding paper<sup>1</sup> the Dirac electron equations were explicitly solved under the following conditions: (a) a velocity equal or nearly equal to  $c$ , so that the two spin states were longitudinal, that is, pure helicity states; (b) a pure energy state, with eigenvalue  $W$ ; (c) no  $z$  dependence of the wave function, so that there was certainly no  $z$  component of the particle's momentum; (d) a bending of the beam parallel to the  $x, y$  plane as far as momentum (not necessarily velocity) was concerned, in such a way that a pure helicity state was conserved; (e) an  $x, y$  distribution of the wave amplitude such that the current- and spin-density vectors,  $\mathbf{j}$  and  $\boldsymbol{\sigma}$  (which are collinear in the extreme relativistic limit), had a nonzero  $z$  component obeying the formula

$$Wj_z = \partial_x \sigma_y - \partial_y \sigma_x \quad (1)$$

or, in integral form,

$$W \iint j_z dx dy = \oint (\sigma_x dx + \sigma_y dy). \quad (2)$$

The "translational inertial spin effect" corresponds precisely to this transverse deflection of the two helicity states, in opposite  $z$  directions, together with the nullity of the  $k_z$  momentum component of the particles. On the whole, with a contour integral taken outside the beam, the effect is zero; but it is predicted to be locally nonzero, and thus should be observable by a detailed exploration of the current lines describing the flux of the Dirac current, that is, the probabilities of transitions to the localized states of the particles.

In the present paper a similar deduction will be carried out for the photon. The Maxwell equations will be solved using the Borgnis<sup>2</sup> technique, which is quite suitable here; an *essentially complex*  $\mathbf{E}, \mathbf{H}$  wave function

will be taken (a) such that  $\mathbf{H} = \pm i\mathbf{E}$ , that is, the polarization state will be purely circular, either with positive or negative helicity; (b) time-dependent through a common factor  $\exp(iWt)$ , with  $W > 0$  fixed; (c)  $z$ -independent; (d) arbitrarily  $x, y$ -dependent. It will then be shown (Sec. II) that the components of the Poynting energy-density vector

$$\mathbf{S} = \mathbf{E}^* \times \mathbf{H} + \mathbf{E} \times \mathbf{H}^* \quad (3)$$

obey the formula

$$\pm 2WS_z = \partial_x S_y - \partial_y S_x, \quad (4)$$

that is, although the  $k_z$  momentum of the photons is identically zero, the two pure helicity states are deflected in opposite  $z$  directions according to their sign. This is, of course, the gauge-independent formulation of the "translational inertial spin effect" in the photon case.

In Sec. III an experimental test will be discussed briefly; it is based on the limiting case of total reflection which, according to classical optics, is the only reflection or refraction case in which a pure circular polarization, or photon helicity state, is preserved.

In Sec. IV the transverse potential (tangent to the Borgnis<sup>2</sup> surfaces) will be introduced; then using de Broglie's<sup>3</sup> expressions for the current- and spin-density 4-vectors,  $j$  and  $\sigma$ , a formula similar to (1) will be deduced. As the  $\mathbf{j}$  and  $\pm\boldsymbol{\sigma}$  3-vectors turn out to be just  $1/W$  times the Poynting 3-vector  $\mathbf{S}$ , this amounts to saying that formula (4) is precisely the expression of the photon's inertial spin effect.

The above  $j$  and  $\sigma$ 's, which are collinear, are time-like, non-null 4-vectors. It is shown in Sec. V that using de Broglie's<sup>3</sup> expressions with the longitudinal gauge potential yields other current- and spin-density 4-vectors,  $k$  and  $\pm\tau$ , which are collinear and orthogonal to  $j = \pm\sigma$ , and which satisfy the same typical formula for the inertial spin effect as  $j$  and  $\sigma$ ; this amounts to saying that the gauge can be adjusted in such a way

<sup>1</sup> O. Costa De Beauregard, Phys. Rev. **134**, B471 (1964). See also Ann. Inst. H. Poincaré **2**, 131 (1965).

<sup>2</sup> F. Borgnis, Ann. Physik **35**, 359 (1939); the Borgnis technique, which we use with Cartesian coordinates, has been defined more generally for a class of curvilinear coordinates.

<sup>3</sup> L. de Broglie, *La mécanique ondulatoire du photon* (Hermann & Cie, Paris, 1940), Vol. 1, Chap. VIII.

that  $J = j + k$  and  $\Sigma = \sigma + \tau$ , which obey the typical formula, become null 4-vectors.

It is well known that in photon theory the physical interpretation of both the current-<sup>3</sup> and the spin-density<sup>4</sup> 4-vectors is difficult. So, in the photon case, it may be safe to say that the unambiguous expression for the translational inertial spin effect in the situation characterized by postulates (a) to (d) is formula (4), which can be experimentally tested as explained in Sec. III.

## II. EXPRESSION OF THE EFFECT IN TERMS OF THE FIELD STRENGTHS ALONE

According to postulates (a) to (e) above, and following Borgnis<sup>2</sup> method, we consider *essentially complex* solutions of the equation

$$(\partial_x^2 + \partial_y^2 + W^2)U(x, y) = 0, \quad (5)$$

which is the corresponding reduced expression of the d'Alembert vacuum equation; units such that  $c = 1$  and  $\hbar = h/2\pi = 1$  are used. Apart from the common phase factor  $\exp(iWt)$ , the Borgnis<sup>2</sup> formulas for the "electric"- and the "magnetic"-type solutions,  $(E)$  and  $(H)$ , respectively, of the vacuum Maxwell equations are

$$\begin{aligned} (E): H_x &= iW\partial_x U, & H_y &= -iW\partial_x U, & E_z &= W^2 U; \\ (H): E_x &= \pm W\partial_y U, & E_y &= \mp W\partial_x U, & H_z &= \pm iW^2 U; \end{aligned} \quad (6)$$

according to postulate (a), the scalar function  $U$  is taken to be the same for both  $(E)$  and  $(H)$ , and a relative phase factor  $\pm i$  is introduced.

The components of the Poynting density current 3-vector [Eq. (3)] are

$$\begin{aligned} S_x &= 2iW^3(U^*\partial_x U - U\partial_x U^*), \\ S_y &= 2iW^3(U^*\partial_y U - U\partial_y U^*), \\ S_z &= \pm 2iW^2(\partial_x U^*\partial_y U - \partial_y U^*\partial_x U); \end{aligned} \quad (7)$$

thus, although the  $z$  component of the photon's momentum is identically zero (owing to the postulated  $z$  independence of the  $\mathbf{E}$ ,  $\mathbf{H}$  wave), the  $S_z$  component of the Poynting  $\mathbf{S}$  vector is nonzero; the two helicity states of the photon, respectively, specified by the signs  $+$  and  $-$ , are deflected in opposite directions of the  $z$  coordinate.

One deduces easily from the expressions (7) the formula (4) which is, in integral form,

$$W \iint S_z dx dy = \pm \frac{1}{2} \oint (S_x dx + S_y dy). \quad (8)$$

It should be noted that, being quadratic in  $U$  and its derivatives, formulas (4) and (8) would *not* hold if a real instead of a complex wave function were used.

<sup>4</sup> J. M. Jauch and F. Rohrlich, *The Theory of Photons and Electrons* (Addison-Wesley Publishing Company, Reading, Massachusetts, 1955), Chap. 2-8, p. 40.

## III. A PROPOSED EXPERIMENTAL TEST OF THE PHOTON INERTIAL SPIN EFFECT: THE LIMITING CASE OF TOTAL REFLECTION

According to classical optics, the only case of reflection or refraction where a pure circular polarization of a plane monochromatic incident beam is conserved is the limiting case of total reflection. The Borgnis method is easily adapted to that case: Following a well known recipe, one simply performs the substitution

$$W \rightarrow nW, \quad \mathbf{E} \rightarrow \epsilon^{1/2}\mathbf{E}, \quad \mathbf{H} \rightarrow \mu^{1/2}\mathbf{H}, \quad n = (\epsilon\mu)^{1/2}, \quad (9)$$

and thus obtains a solution for a medium characterized by the electric and magnetic permeability constants  $\epsilon$  and  $\mu$ .

Formula (4) would not be easily applied to the quasis discontinuous case of reflection, for it would involve a delicate analysis of the  $\mathbf{E}$  and  $\mathbf{H}$  fields in the quasis discontinuity region. Fortunately, the field strengths  $\mathbf{E}$  and  $\mathbf{H}$  have a very simple distribution both in the ingoing and outgoing beams, and inside the interference region; this will make it quite easy to use formula (8), which will automatically take care of the over-all effect.

We will consider (Fig. 1) the case of a cylindrical beam of rectangular section  $a \times b$  with rays orthogonal to the  $z$  axis, falling on a reflecting plane parallel to the  $a$  side, in the limiting case of total reflection. We take as the picture plane an  $x, y$  incidence plane, the  $x$  axis being parallel to the reflecting plane.  $\frac{1}{2}\pi - \theta$  denotes the incidence and reflection angles, and thus  $2\theta$  the angle between the incident and reflected Poynting vectors; these are constant inside the corresponding beams with a common magnitude  $S_0$ .

Inside the interference region, projected in  $CAB$  on the  $x, y$  plane, the expressions of the complex field strengths may be written as

$$\begin{aligned} H_x &= \pm iE_x = 2iB \sin\theta \sin Y \exp(i\phi), \\ H_y &= \pm iE_y = 2B \cos\theta \cos Y \exp(i\phi), \\ H_z &= \pm iE_z = \pm 2iB \cos Y \exp(i\phi), \end{aligned} \quad (10)$$

with

$$2B^2 = S_0, \quad Y = nWy \sin\theta, \quad \phi = W(t - nx \cos\theta). \quad (11)$$

Thus, according to (3), the expressions of the Poynting vector are

$$\begin{aligned} S_x &= 8B^2 \cos\theta \cos^2 Y = 4S_0 \cos\theta \cos^2(nWy \sin\theta), \\ S_y &= 0, \end{aligned} \quad (12)$$

$S_z = \pm 2B^2 \sin 2\theta \sin 2Y = \pm S_0 \sin 2\theta \sin(2nWy \sin\theta)$ ; formulas (4) and (8) are, therefore, verified, as they had to be.

The mean values of  $S_x$  and  $S_z$  as functions of  $y$  are

$$\bar{S}_x = 2S_0 \cos\theta, \quad \bar{S}_z = 0, \quad (13)$$

the first expression implies that the flux through the  $AH$  and  $BK$  cross sections is conserved.

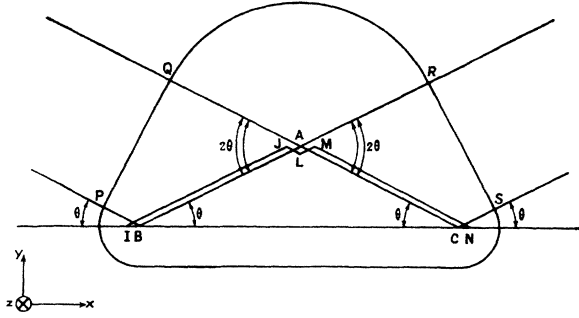

FIG. 1. Integration contours for calculation of the photon's translational inertial spin effect in the limiting case of total reflection.

We are interested in the over-all effect of the abrupt variations of the field strengths through the boundaries  $AB$ ,  $AC$ , and  $BC$ . A contour such as  $PQRS$ , cutting orthogonally the incoming and outgoing beams and closed outside the beams, yields a zero total effect, due to an over-all compensation of the inner sources of  $S_z$  by those existing on the sides of the beam. Thus, to find the effect existing *inside* the beam, we must use the  $IJLMN$  contour traced just inside the beam, and just outside the sources of  $S_z$  which are present inside the beam. Setting

$$l = b/\sin 2\theta = |AB| = |AC|, \quad (14)$$

the contribution of the  $NMLJI$  part of the contour is written as  $-2lS_0 \cos 2\theta$ .

The contribution of the  $IN$  part of the contour depends on the value chosen for  $Y$ , that is, for  $y$ . Owing to the physically active character of the reflecting surface  $BC$ , it is *a priori* unlikely that the value of  $S_x$  along the  $IN$  segment should be  $\bar{S}_x$  defined by (13), because the physically appropriate result could then be obtained as the mean value corresponding to arbitrary positions of the horizontal  $IN$  segment inside the interference region. So we denote by  $\eta$ ,  $0 \leq \eta \leq 1$ , the appropriate value of  $\cos^2 Y$  along the  $IN$  segment, and will fix it *a posteriori*. The contribution of this segment is thus written  $8\eta l S_0 \cos^2 \theta$ .

Finally, in the case we are considering, the line integral in (8) is, with  $\varpi$  denoting the power transported through the  $z = \text{const}$  planes,

$$\pm 2nW\varpi = 2lS_0(4\eta \cos^2 \theta - \cos 2\theta). \quad (15)$$

Another expression for  $\varpi$  involves the deflection  $\delta z$  of the photons in the  $z$  direction, due to the "translational inertial spin effect," and is written as

$$\varpi = lS_0 \delta z \sin 2\theta. \quad (16)$$

From (15) and (16) one deduces the  $l$ - (or  $b$ -) independent expression

$$\delta z = \pm (4\eta \cos^2 \theta - \cos 2\theta)/nW \sin 2\theta. \quad (17)$$

It is physically obvious that, if  $n \rightarrow 1$  and thus  $\theta \rightarrow 0$ ,  $\delta z$  must  $\rightarrow 0$ ; this will be the case if, and only if,  $\eta = \frac{1}{4}$ ,

a value which, as expected, differs from the mean value  $\frac{1}{2}$  of  $\cos^2 Y$ . Thus

$$\delta z = \pm (1/2nW) \tan \theta. \quad (18)$$

Instead of the energy of the photons, it will be more significant to introduce the wavelength of the beam in the medium

$$\lambda = 2\pi/nW$$

and, instead of the deflection  $\delta z$  per helicity state, the linear separation

$$\Delta z = 2\delta z$$

between the two states or, even better, its ratio to  $\lambda$ . Moreover, the significant quantity  $\Delta z/\lambda$  will be multiplied by  $N$  if  $N$  additive (or quasiadditive) deviations of the kind just described are produced. Finally,

$$\Delta z/\lambda = N(1/2\pi) \tan \theta. \quad (19)$$

In the case where  $\theta$  is infinitely small, this formula is the same as the one found for the extreme relativistic spin- $\frac{1}{2}$  particles.<sup>1</sup>

Figure 2 shows the linear separation  $\Delta z$  of the two pure helicity states inside the outgoing beam (right), as compared with the arbitrary polarization state inside the incoming beam (left).

#### IV. EXPRESSION OF THE EFFECT IN TERMS OF THE FIELD STRENGTHS AND THE TRANSVERSE POTENTIALS

In both cases of ( $E$ ) and ( $H$ ) type of Borgnis solutions (6), a potential satisfying the Lorentz condition is easily found, namely

$$\begin{aligned} (E): \quad & A_x = A_y = V = 0, \quad A_z = iWU, \quad \partial_x A_z = 0; \\ (H): \quad & A_x = \pm i\partial_y U, \quad A_y = \mp i\partial_x U, \\ & A_z = V = 0, \quad \partial_x A_x + \partial_y A_y = 0. \end{aligned} \quad (20)$$

These are transverse potentials; that is, the complex  $A$  vectors are orthogonal to the complex  $U(x, y) = \text{const}$  surfaces.

Inserting (6) and (20) in the de Broglie<sup>3</sup>-type formulas for the current- and spin-density 4-vectors in photon

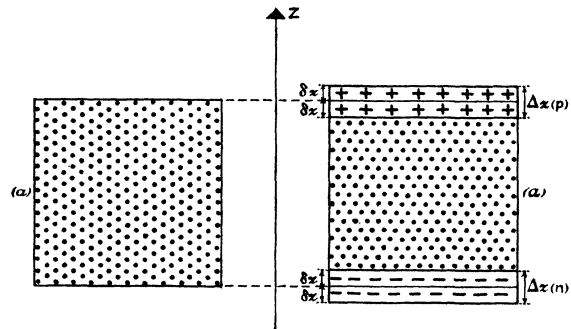

FIG. 2. Separation of the two-photon helicity states in the limiting case of total reflection. Cross sections of: left, incoming beam, right, outgoing beam; ( $a$ ) any polarization state, ( $p$ ) positive helicity, ( $n$ ) negative helicity.

theory,

$$\begin{aligned} \mathbf{j} &= i(\mathbf{A}^* \times \mathbf{H} + V^* \mathbf{E}) + \text{c.c.}, \\ \boldsymbol{\sigma} &= \mathbf{E}^* \times \mathbf{A} + V \mathbf{H}^* + \text{c.c.}, \\ j_t &= i \mathbf{A}^* \cdot \mathbf{E} + \text{c.c.}, \\ \sigma_t &= \mathbf{A}^* \cdot \mathbf{H} + \text{c.c.}, \end{aligned} \quad (21)$$

yields

$$\begin{aligned} j_x &= \pm \sigma_x = 2iW^2(U^* \partial_x U - U \partial_x U^*), \\ j_y &= \pm \sigma_y = 2iW^2(U^* \partial_y U - U \partial_y U^*), \\ \pm j_z = \sigma_z &= 2iW(\partial_x U^* \partial_y U - \partial_y U^* \partial_x U), \\ j_z &= \pm \sigma_t = 2W(W^2 U^* U + \partial_x U^* \partial_x U + \partial_y U^* \partial_y U). \end{aligned} \quad (22)$$

By comparing formulas (7) and (22) one notices that

$$\mathbf{S} = W \mathbf{j} = \pm W \boldsymbol{\sigma}. \quad (23)$$

The Poynting energy-density 3-vector  $\mathbf{S}$  equals  $W$  times the current-density 3-vector  $\mathbf{j}$  defined above. Assuming that the photon's energy  $W$  is positive, one finds that the fourth component of the  $j$  4-vector is positive definite, as was expected for a position probability density. One also deduces from formulas (22) that

$$2W j_z = \partial_x \sigma_y - \partial_y \sigma_x, \quad (24)$$

which is the canonical formula for the "translational inertial spin effect," with a factor 2 which was absent in the electron case.<sup>1</sup>

Finally, the above formulas (4) and (8) are directly interpretable in terms of the general theory of the translational inertial spin effect.

The only property of the collinear 4-vectors  $j$  and  $\sigma$  which is not satisfactory is that they are time-like, not null 4-vectors [see below, formula (38)]. We will show now that it is possible to adjust the gauge in such a way that this feature disappears.

## V. THE LONGITUDINAL GAUGE POTENTIAL

Now we consider the gauge potential

$$\mathfrak{A}_x = \pm \partial_x U, \quad \mathfrak{A}_y = \pm \partial_y U, \quad \mathfrak{A}_z = 0, \quad \mathfrak{B} = \pm iWU, \quad (25)$$

with the same  $U(x,y)$  function as above, and the same correspondence between the two signs and the helicity states; this potential is longitudinal in the sense that the  $\mathfrak{A}$  complex vector is normal to the  $U(x,y) = \text{const.}$  complex surfaces.

Inserting (6) and (25) in the de Broglie-type formulas (21) yields the new current and spin density 4-vectors  $k$  and  $\tau$ ,

$$\begin{aligned} k_x &= \pm \tau_x = -2W^2 \partial_y (U^* U), \quad k_y = \pm \tau_y = 2W^2 \partial_x (U^* U), \\ \pm k_z = \tau_z &= 2W(\partial_x U^* \partial_x U + \partial_y U^* \partial_y U - W^2 U^* U), \\ k_t &= \pm \tau_t = 2iW(\partial_x U^* \partial_y U - \partial_y U^* \partial_x U). \end{aligned} \quad (26)$$

They satisfy the same canonical formula as  $j$  and  $\sigma$ , that is

$$2W k_z = \partial_x \tau_y - \partial_y \tau_x; \quad (27)$$

so any choice  $\eta \mathfrak{A}$ ,  $\eta \mathfrak{B}$  of the gauge (25) will yield a

current and a spin density 4-vector

$$J = j \pm \eta k, \quad \Sigma = \sigma \pm \eta \tau, \quad (28)$$

satisfying the "canonical formula" for the "translational spin effect"

$$2W J_z = \partial_x \Sigma_y - \partial_y \Sigma_x. \quad (29)$$

From formulas (22) and (26) one deduces

$$\mathbf{j} \cdot \mathbf{k} - j_t \cdot k_t = 0 \quad (30)$$

and

$$\begin{aligned} j_t^2 - \mathbf{j}^2 = k_t^2 - \mathbf{k}^2 &= W^6 (U^* U)^2 + W^4 \{ (U^* \partial_x U)^2 \\ &+ (U \partial_x U^*)^2 + (U^* \partial_y U)^2 + (U \partial_y U^*)^2 \\ &+ W^2 \{ (\partial_x U^* \partial_x U)^2 + (\partial_y U^* \partial_y U)^2 \\ &+ (\partial_x U^* \partial_y U)^2 + (\partial_y U^* \partial_x U)^2 \}. \end{aligned} \quad (31)$$

The  $j$  and  $k$  4-vectors are orthogonal, with squares of opposite signs. Thus, there is one and only one choice of  $|\eta|$  that renders the  $J$  and  $\Sigma$  4-vectors defined by (28) null 4-vectors:  $|\eta| = 1$ . This yields two determinations of the  $J$  and  $\Sigma$  4-vectors.

The  $J_t$  component of  $J$  is easily calculated as

$$\begin{aligned} J_t &= 2W[W^2 U^* U + \partial_x U^* \partial_x U + \partial_y U^* \partial_y U \\ &\pm i\eta(\partial_x U^* \partial_y U - \partial_y U^* \partial_x U)]. \end{aligned} \quad (32)$$

Since it is positive definite, and owing to the double determination of  $k$ , it turns out that the  $j$  and  $k$  4-vectors are, respectively, time-like and space-like.

## VI. CONCLUSIONS

In its gauge-independent form as given in Sec. II, the photon's "translational inertial spin effect" is unambiguously deduced under the hypothesis that, on the quantum level, the components of the photon's wave function are essentially complex; thus, experiments such as the one proposed in Sec. III should be tests of both the "translational inertial spin effect," and the complex or real character of the photon's wave function. It should be recalled that very strong theoretical arguments have been given in favor of the complex rather than real character of the physical wave function of the photon.<sup>5</sup>

The introduction of the transverse potential waves, which was performed in Sec. IV, shows a connection between the formulas of Sec. II and those of the theory<sup>1</sup> of the inertial spin effect with moving particles of spin  $\frac{1}{2}$ .

An adjustment of the longitudinal potential waves, or gauge waves, is possible, which renders the current- and spin-density 4-vectors, as defined by de Broglie, null vectors, as they ought to be; but the double determination of the corresponding gauge, together with other known arguments,<sup>3,4</sup> tends to give a merely formal character to the gauge-dependent expressions of the new effect.

<sup>5</sup> P. A. M. Dirac, *Quantum Mechanics*, (Clarendon Press, Oxford, England, 1947), 3rd. ed., Chap. I.