

Superconducting Penetration Depth of Niobium

B. W. MAXFIELD AND W. L. McLEAN

Rutgers, The State University, New Brunswick, New Jersey

(Received 12 April 1965)

The variation with temperature of the penetration depth of weak magnetic fields into niobium has been measured. The variation was more rapid than expected from the BCS theory of superconductivity, in contrast to the situation in previously measured superconductors where it was less rapid. Just as in the previous cases, the results here can be understood in terms of a variation of the energy gap different from that predicted by the BCS theory. A comparison with the energy gap deduced by Dobbs and Perz from their ultrasonic-attenuation measurements is given. The penetration depth at absolute zero, $\lambda(0)$, is estimated from the present results to be $470 \pm 50 \text{ \AA}$, while the London penetration depth $\lambda_L(0)$ is $390 \pm 50 \text{ \AA}$.

I. INTRODUCTION

THE measurement of the magnetization curve of pure niobium below its superconducting transition temperature by Stromberg and Swenson¹ showed that instead of the usual strong diamagnetism (the Meissner effect) expected in a long cylinder parallel to the external field, a large penetration of flux into the niobium occurred at fields well below those required to destroy the superconducting state. This is just what would occur if a mixed state of the kind predicted by Abrikosov² or by Goodman³ were to form, what is now known as "type II superconductivity." Pippard⁴ had shown from his consideration of the long-range order of the superconducting state that the condition for a mixed state to form was governed by the relative sizes of the coherence length and the penetration depth, where the coherence length is a measure of the loss of condensation energy caused by the variation of the order parameter at a superconducting-normal phase boundary, and the penetration depth is a measure of the flux penetration into the superconductor, being related to the lowering of the Gibbs free energy owing to flux penetration into the superconducting material.

It was thus of interest to attempt a direct measurement of the penetration depth in niobium, not only to obtain its size, but to see if there were any peculiarities in its variation with temperature which could not be accounted for within the framework of the Bardeen, Cooper, Schrieffer⁵ theory of superconductivity.

The penetration depth is defined by the relation $\lambda = \int_0^\infty B(z) dz / B(0)$ where $B(z)$ is the flux density produced by a static external field at a depth z below the surface of a semi-infinite superconductor occupying the region $z \geq 0$. Early measurements of the penetration depth in colloidal mercury showed that the variation with temperature could be expressed in the form

$d\lambda/dy = \text{constant}$, where $y = (1-t^4)^{-1/2}$ and $t = T/T_c$.⁶

A combination of the London equations for superconductors⁷ (which give $\lambda^{-2} = 4\pi N_s e^2 / m$, where N_s is the density of superelectrons, e and m the charge and mass of the electron) and the two-fluid thermodynamic model of Gorter and Casimir⁸ [which suggests $N_s = N(1-t^4)$, where N is the electron density] gives the relation

$$\lambda = y(4\pi N e^2 / m)^{-1/2}. \quad (1)$$

The experimentally determined constant was however significantly higher than $d\lambda/dy = (4\pi N e^2 / m)^{-1/2}$ but the cause of the discrepancy was clarified by Pippard⁹ when he showed that the London equation relating vector-potential to current density, $\mathbf{J}(\mathbf{r}) = - (N_s e^2 / m) \mathbf{A}(\mathbf{r})$, was a limiting form of a more general nonlocal relation. A similar nonlocal relation

$$\mathbf{J}(\mathbf{r}) = - \frac{3}{4\pi \xi_0 \Lambda_T} \int \frac{\mathbf{R} \mathbf{R} \cdot \mathbf{A}(\mathbf{r}')}{R^4} J(R, T) d^3 \mathbf{r}' \quad (2)$$

follows from the BCS theory. Here, $\mathbf{R} = \mathbf{r} - \mathbf{r}'$, with ξ_0 the coherence length, and Λ_T given by

$$1 - \frac{\Lambda}{\Lambda_T} = \frac{1}{2} \int_0^\infty \text{sech}^2 \left\{ \left(\frac{1}{2} \right) [y^2 + \beta^2 \epsilon(T)^2]^{1/2} \right\} dy, \quad (3)$$

where $\Lambda = m / N e^2$, $\beta = 1 / kT$, $\epsilon(T)$ is the energy gap and $J(R, T)$ is a function which does not vary much with temperature. The dependence of the penetration depth on temperature which comes from these relations is similar to that given by Eq. (1) but there are some significant differences which have led recently to more accurate experimental studies. The present state of comparison has been reviewed by Waldram.¹⁰ The theory predicts $d\lambda/dy$ to be a constant for temperatures close to the transition temperature but that at lower temperatures $d\lambda/dy$ increases. (Eventually, for

¹ T. F. Stromberg and C. A. Swenson, Phys. Rev. Letters **9**, 37 (1962).

² A. A. Abrikosov, Zh. Eksperim. i Teor. Fiz. **32**, 1442 (1957) [English transl.: Soviet Phys.—JETP **5**, 1174 (1957)].

³ B. B. Goodman, Phys. Rev. Letters **6**, 597 (1961).

⁴ A. B. Pippard, Proc. Cambridge Phil. Soc. **47**, 617 (1951).

⁵ J. Bardeen, L. N. Cooper, and J. R. Schrieffer, Phys. Rev. **108**, 1175 (1957).

⁶ J. G. Daunt, A. R. Miller, A. B. Pippard, and D. Shoenberg, Phys. Rev. **74**, 842 (1948).

⁷ F. London and H. London, Proc. Roy. Soc. (London) **A149**, 71 (1935), and Physica **2**, 341 (1935).

⁸ C. J. Gorter and H. B. G. Casimir, Z. Physik. **35**, 963 (1934).

⁹ A. B. Pippard, Proc. Roy. Soc. (London) **A216**, 547 (1953).

¹⁰ J. R. Waldram, Advan. Phys. **13**, 1 (1964); and Rev. Mod. Phys. **36**, 187 (1964).

very low temperatures $d\lambda/dy$ decreases to zero on account of the exponential variation with temperature of the number of electrons excited above the energy gap—as has been confirmed experimentally by Erlbach, Garwin, and Sarachik.¹¹) Most recent experiments have shown that $d\lambda/dy$ does not increase as much as predicted by the theory. Waldram¹⁰ has shown in the case of tin that the difference may be resolved by using in Eq. (3) an empirically determined energy gap, rather than the one predicted by the theory, which is sensitive to some of the simplifying mathematical assumptions that are made in order to arrive at a comparison with experiment.

We conclude this introduction with a remark on the absolute value of the penetration depth. Experimentally it has never been possible to obtain the absolute value of λ as accurately as changes in λ and so the relation between the value of λ at absolute zero (where $y=1$) and the value of $d\lambda/dy$ has never been established with accuracy: Eq. (2) for instance indicates that they should be the same. In the analysis of the results in Sec. IV, we require an estimate of the absolute value of λ for the purpose of making certain small corrections, and there we use the value of $(d\lambda/dy)$ measured near the transition temperature.

II. EXPERIMENTAL METHOD

The change in penetration depth with temperature was determined from the dependence of the self-inductance of a coil on the flux penetration into its superconducting niobium core. Changes in the self-inductance were measured at two different frequencies: at 4 Mc/sec by the “active” method used previously for penetration-depth measurements by Schawlow and Devlin¹² and by Sharvin and Gantmakher¹³ and at 80 Mc/sec using the “passive” method used previously

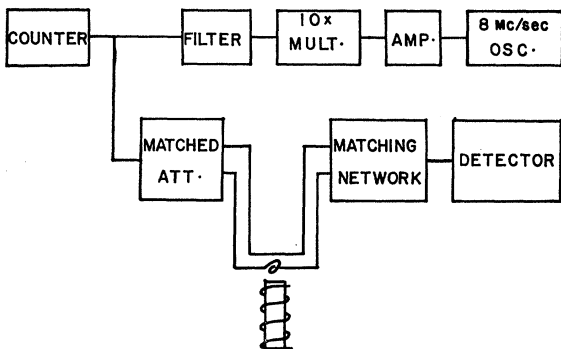

FIG. 1. Representation of the passive method.

by Chambers¹⁴ and by McLean.¹⁵ The niobium sample and coil were enclosed in a liquid-helium cryostat so that the resonant frequency could be measured at temperatures between 1.2 and 20°K.

A. The Active Method

In this arrangement the coil is part of the tank circuit of a Franklin oscillator¹⁶ and thus governs the operating frequency which in this experiment was measured directly by a Hewlett-Packard 524C counter. The frequency of the oscillator is not usually the same as the resonant frequency of the tank circuit and the active method is useful only when the relation between these two frequencies does not change appreciably during a low-temperature run. Deviations are most likely to occur at temperatures close to the transition temperature where the rf power loss in the superconductor rises rapidly to the normal-state value and the resonance curve of the tank circuit broadens. To allow for such systematic errors, measurements of the penetration depth were made also by the “passive method” which may be used without error as close to the transition temperature as the temperature control will permit.

To avoid heating effects in the sample near the transition temperature, it was necessary to adjust the amplitude of the oscillator so that it would just operate. The variation of frequency with temperature near the transition was then independent of small increases in the amplitude.

B. The Passive Method

A diagram of the rf circuit for the passive method is shown in Fig. 1. The coil in this case was a self-resonant superconducting helix (which was kept in thermal contact with a helium bath at 4.2°K) loosely coupled to a loop in one of the conductors of a transmission line which connected the tunable oscillator to a square-law detector. The detector was matched to the oscillator at frequencies well away from the resonant frequency of the helix f_0 . When the oscillator frequency was varied and passed through f_0 , the resonance of the helix caused a large mismatch and the power P reaching the detector passed through a minimum, as may be seen from Figs. 2(a) and 2(b). One considerable advantage of the passive method over the active method is that it is possible to carry out a circuit analysis, which does not depend on the nonlinear effects occurring in the oscillator. The curves of Figs. 2(a) and 2(b) agree well with such an analysis which has been described before.¹⁵

Apart from the mismatch caused by the helix, if other causes of reflected waves are not carefully compensated in the initial matching of the detector to the

¹¹ E. Erlbach, R. L. Garwin, and M. P. Sarachik, *I. B. M. J. Res. Develop.* **4**, 107 (1960).

¹² A. L. Schawlow and G. E. Devlin, *Phys. Rev.* **113**, 120 (1959).

¹³ Yu. V. Sharvin and V. F. Gantmakher, *Zh. Eksperim. i Teor. Fiz.* **39**, 1269 (1960) [English transl.: *Soviet Phys.—JETP* **12**, 866 (1961)].

¹⁴ R. G. Chambers, *Proc. Cambridge Phil. Soc.* **52**, Pt. 2, 363 (1956).

¹⁵ W. L. McLean, *Proc. Phys. Soc. (London)* **79**, 572 (1962).

¹⁶ See, for example, W. A. Edson, *Vacuum-Tube Oscillators* (John Wiley & Sons, Inc., New York, 1953).

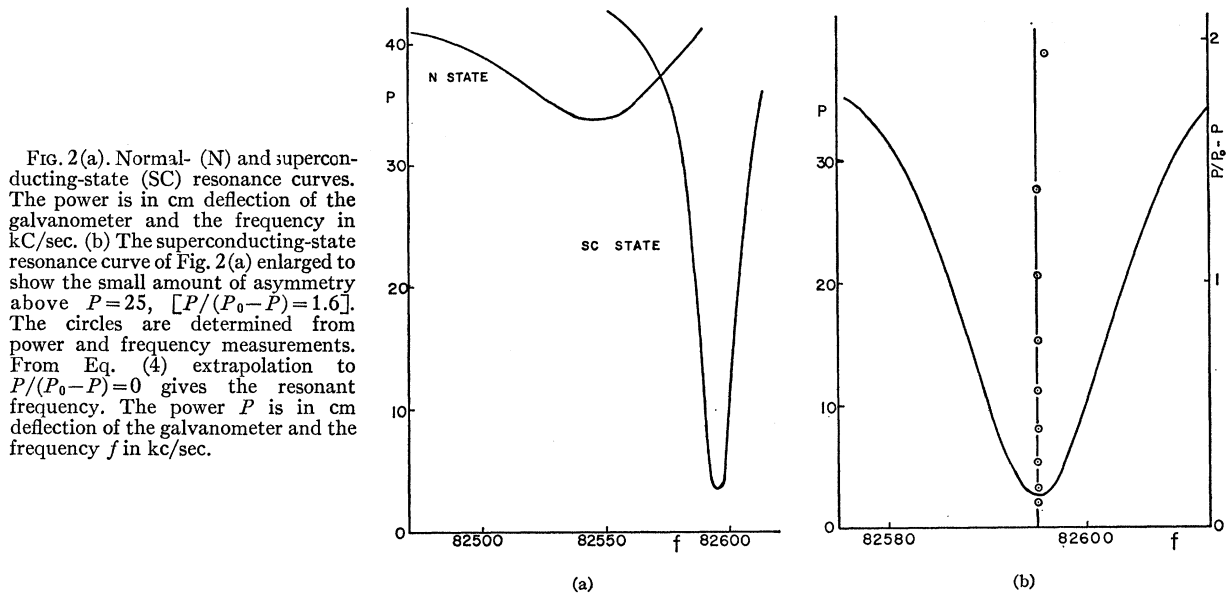

FIG. 2(a). Normal- (N) and superconducting-state (SC) resonance curves. The power is in cm deflection of the galvanometer and the frequency in kc/sec. (b) The superconducting-state resonance curve of Fig. 2(a) enlarged to show the small amount of asymmetry above $P=25$, [$P/(P_0-P)=1.6$]. The circles are determined from power and frequency measurements. From Eq. (4) extrapolation to $P/(P_0-P)=0$ gives the resonant frequency. The power P is in cm deflection of the galvanometer and the frequency f in kc/sec.

oscillator, the resonance curves are asymmetrical. In such a case, the circuit analysis shows that the resonant frequency may most easily be found by fitting the equation

$$\frac{1}{2}(f_1+f_2) = f_0 + AP/(P-P_0) \quad (4)$$

to the experimental data. Here f_1 and f_2 are the two frequencies for which the power level on the resonance curve is P , f_0 the resonant frequency of the helix, A a constant and P_0 the power level well off resonance. The losses in the tank circuit can be expressed in terms of its uncoupled bandwidth by the relation

$$\Delta f_B = \left[\{ (f_1-f_2)^2 - (f_1+f_2-2f_0)^2 \} \times \frac{P_0}{P_m} \left(\frac{P_0-P}{P-P_m} \right)^{1/2} \right]^{1/2}, \quad (5)$$

where P_m is the minimum power level on the resonance curve.

The chief limitation in the passive method arose from the temperature of the helix rising as the temperature of its niobium core was raised. Although the two were in poor thermal contact, the thermal connection between the helix and the helium bath was insufficient to prevent some change in the resonant frequency on account of the increase of flux penetration in the helix. A correction for this was made by replacing the niobium core by a cylinder of tin (see Sec. IIF, below) and measuring the frequency change between 4 and 9°K.

C. Thermometry

A Texas Instruments germanium thermometer was used to measure the temperature of the sample. The resistance thermometer was calibrated between 1.2 and

4.2°K against the vapor pressure of liquid helium using the 1958 He⁴ scale of temperature, and above 4.2°K by comparison with a constant-volume helium-gas thermometer. A method outlined by Franck and Martin¹⁷ was used to calculate temperatures from the gas thermometer pressure readings. Room temperature and the temperature of an agitated open helium bath determined from the liquid-helium vapor-pressure tables mentioned above were taken as two fixed points. As a check point the transition temperature of annealed pure lead was measured to be 7.186°K which is in good agreement with 7.193°K measured by Franck and Martin.¹⁷ The absolute temperature is probably correct to within $\pm 0.01^\circ\text{K}$ while the error in temperature differences is considerably less.

D. Measurement of the Transition Temperature

The magnetic transition of the niobium sample was measured using a simple ac induction technique, with measuring fields of about 0.25 to 0.5 G peak-to-peak. The width of the transition (from 10 to 90% superconducting) was 0.007°K with a hysteresis of 0.002°K, centered about 9.19°K which was taken to be the transition temperature.

In analyzing data in measurements of the penetration depth, it has been common practice to pick a transition temperature which gives the best straight-line fit to Eq. (1) near the transition temperature. Here, however, the results were analyzed using the directly measured transition temperature.

E. Sample Preparation

The niobium sample was a cylinder about 4 in. long and 0.25 in. in diameter. It was electropolished using a

¹⁷ J. P. Franck and D. L. Martin, Can. J. Phys. 39, 1320 (1961).

sulfuric acid and hydrofluoric acid solution.¹⁸ This removed bumps but did not polish on a fine scale. A chemical dip consisting of equal parts of concentrated nitric, sulfuric, and hydrofluoric acids and water gave a fine scale polish. The surface was fairly smooth under low power magnification.

The resistivity ratio of the niobium sample $R_{300}/R_{4.2}$ was found to be 115. The resistivity was determined at the two temperatures from the rate of decay of eddy currents,¹⁹ superconductivity being quenched at the lower temperature by a strong magnetic field. If one assumes that the coherence length is equal to the London penetration depth at $T=0^\circ\text{K}$ (see Discussion, Sec. IVB), and $2\epsilon(0)/kT_c=3.52$, then the Fermi velocity $v_0=2.6\times 10^7$ cm/sec. This gives a mean free path $l=4.0\times 10^{-5}$ cm if one takes $m/Ne^2=4\pi\lambda_L^2(0)$.

F. Systematic Errors

In order to measure the effect of the superconducting helix in the passive method one wants a normal metal sample of such purity that the skin depth does not change greatly between 4 and 9°K. This was accomplished by adding 0.15 at. % of 99.999% pure indium to 99.999% pure tin. The resulting resistance ratio was $R_{300}/R_{4.2}=84$. A 0.25-in. rod of this alloy was cast in a graphite mold and cooled quickly. The rod was machined to the desired size, annealed for 14 days at 200°C, and then chemically polished in a 45% concentrated nitric acid, 45% concentrated sulfuric acid, and 10% concentrated hydrofluoric acid solution. The surface was smooth under low-power magnification except for a few shallow pits.

An error made in correction for the effect of the superconducting helix would show up directly in the measured penetration depth but the agreement which was found with the active method (see below) rules out the possibility of a significant error. For $y < 2$ the helix correction is a large percentage of the total effect measured. Here one relies more heavily upon the active method but the active method is expected to be free from systematic errors at low reduced temperatures. Within the limits of accuracy dictated by the helix correction the two methods agree in this region as well as at the higher temperatures where $y > 2$. Over the relatively small temperature range $y=2$ to $y=4$, the penetration depth in the helix changes only slightly (the transition temperature of the helix was about 11°K). Hence when slopes near T_c are being compared the correction for the helix is small.

The passive-method measurements were repeated with different helices and no significant difference was found in the measured penetration depths. Etching and repolishing the niobium sample so that it was obviously

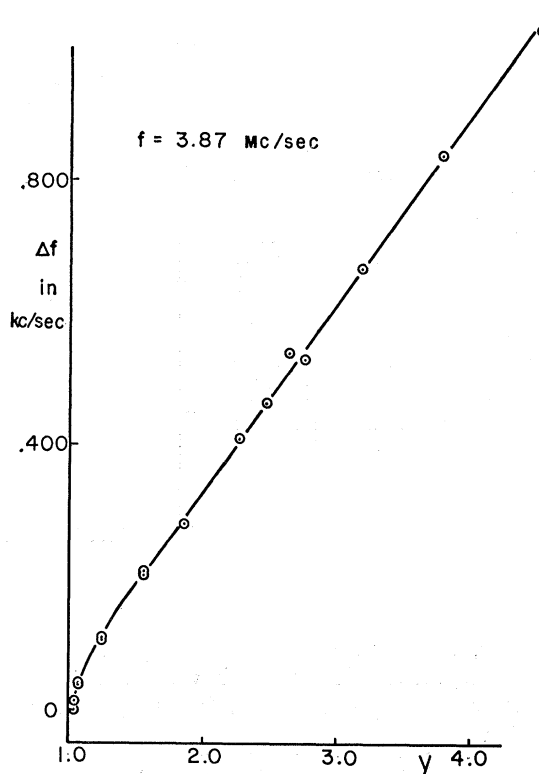

FIG. 3. Results of an active-method run.

rougher (the diameter was decreased by about 0.008 in.) increased $(d\lambda/dy)T_c$ from 440 Å to 465 Å.

To prevent magnetic flux from being trapped in normal regions in the samples, the earth's field at the sample was cancelled to about 2%. This precaution is necessary because the size of the normal regions would change with temperature and therefore cause a spurious change in the resonant frequency of the tank circuit. This effect is likely to be most serious at the lower frequencies where the normal-state skin depth is large.

III. RESULTS

A. Frequency Variation with Temperature

These experiments measure directly the change in resonant frequency of the tank circuit with y . Figure 3 shows the results of a typical active method run, while Fig. 4 shows the results of four different runs using the passive method. The solid line below the passive method results was obtained by subtracting the effect of the superconducting helix measured by replacing the niobium by the tin sample.

Strains or large quantities of impurities can cause the rf resistive transition to be spread over a wide temperature range. Flux-trapping normal regions have temperature-dependent losses associated with them and would also contribute to the spread of the transition. One can

¹⁸ W. J. McG. Tegart, *The Electrolytic and Chemical Polishing of Metals* (Pergamon Press, New York, 1959).

¹⁹ C. P. Bean, R. W. Deblois, and L. B. Nesbitt, *J. Appl. Phys.* 30, 1976 (1959).

therefore assess the quality of the sample from the breadth of the rf resistive transition.

As mentioned in Sec. IIB, the passive method allows a determination of the losses in the tank circuit as well as its resonant frequency. In Fig. 5 the ratio of the surface resistance of the niobium sample in the superconducting state to that in the normal state, R_s/R_N , is plotted as a function of $(T_c - T)$. Also plotted is the ratio of the surface reactance in the superconducting state to that in the normal state, X_s/X_N , as a function of $(T_c - T)$. The niobium sample showed a resistive transition typical of a pure strain-free superconductor.

The penetration depth measured in these experiments should only differ significantly from the static field penetration depth at temperatures above $y=7$ where the surface resistance is becoming appreciable. For this reason, and also since small errors in the temperature measurement have a large effect at such values of y , only data for which $y < 5$ have been used in the analysis described below.

B. Conversion to the Variation of Penetration Depth with Temperature

The scaling factor necessary to convert from changes in resonant frequency to changes in penetration depth is best determined by doing measurements on a material of known penetration depth. Tin was chosen for this

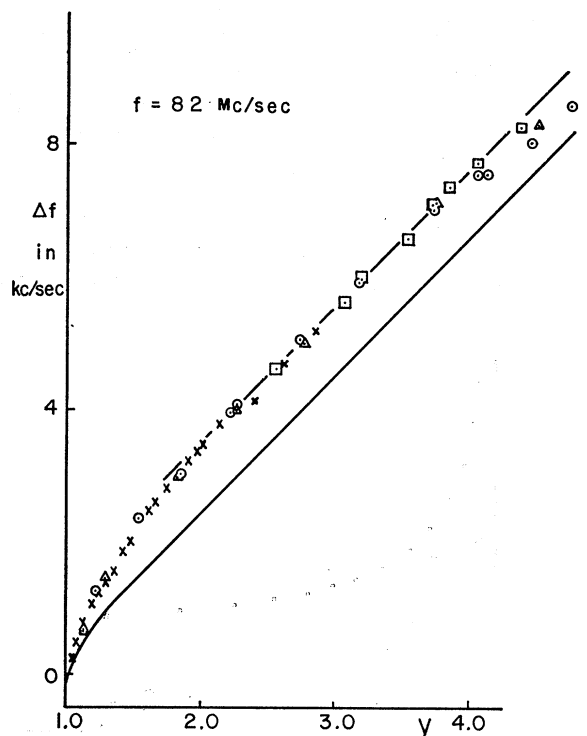

FIG. 4. Results of the passive method. The \odot , \times , \triangle , \square , represent the results of four runs. The lower curve is obtained by correcting the experimental data for effects of the superconducting coil in the tank circuit.

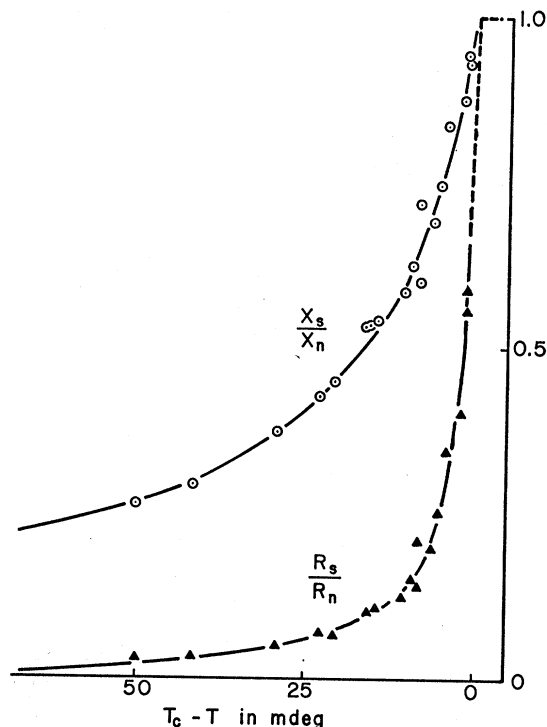

FIG. 5. Behavior of the niobium sample at 82 Mc/sec near the critical temperature. The far left-hand side corresponds to $y=7$.

purpose since there is much information available about its surface impedance (see for instance, Waldram¹⁰). Only the passive method was calibrated in this manner.

In the linear region between $y=2$ and $y=4$ the measured change in frequency as a function of y gives a slope near T_c of $df/dy=2460 \pm 50$ cycles/sec for tin and $df/dy=2070 \pm 50$ cycles/sec for niobium. Using for tin the value $(d\lambda/dy)_{T_c}=520 \text{ \AA}$ given by Waldram, one gets $(d\lambda/dy)_{T_c}=440 \text{ \AA}$ for niobium after making small corrections for differences in the operating frequency and in the size of the two specimens.

The scaling factor $df/d\lambda$ can be obtained approximately by treating the coil as an infinite solenoid of radius r , with a diamagnetic cylindrical core of radius $r_s - \lambda$, where r_s is the true radius of the core. The change of flux when λ changes by $\Delta\lambda$ gives rise to a change in resonant frequency of the tank circuit of

$$\frac{\Delta f}{f} = - \frac{r_s \Delta \lambda}{r^2 - r_s^2} \quad (6)$$

Thus, for the passive method one gets $(d\lambda/dy)_{T_c}=465 \text{ \AA}$ if r is taken to be the distance from the coil axis to the center of the windings of the coil and $(d\lambda/dy)_{T_c}=440 \text{ \AA}$ if r is measured to the inside of the windings. (It is worth noting that it is important to allow for the thermal contraction of the helix.) Since most of the current in the coil flows in a thin layer on

the side nearest the sample, the inside radius should be very close to the average radius of current flow. As determined from Eq. (6), $(d\lambda/dy)_{T_c}$ for the passive method is subject to an error of about $\pm 3\%$ due to possible errors in coil and sample dimensions.

For the active method $(d\lambda/dy)_{T_c}$ was calculated using Eq. (6). Taking the coil radius to the center of the windings gave $(d\lambda/dy)_{T_c} = 480 \text{ \AA}$. Because the distance between the sample and the coil was smaller than in the passive method the corresponding error in $(d\lambda/dy)_{T_c}$ was about $\pm 10\%$ for the active method. The results of both the active and passive methods agree within these limits.

IV. DISCUSSION OF RESULTS

A. Conversion to the "London" Penetration Depth

A comparison of the experimental results with the theory is most easily made through Eq. (3) by first of all calculating the "London" or "local" penetration depth $\lambda_L(T) = (\Delta_T/4\pi)^{1/2}$ from the measured changes in the penetration depth $\lambda(T)$. $\lambda_L(T)$ and $\lambda(T)$ differ because of the nonlocal nature of Eq. (2) but in the present case the difference is not more than 20% because of the comparable sizes of the coherence length ξ_0 and $\lambda_L(0)$. Although the relation between the two penetration depths is quite complicated it is insensitive to the details of the theory. We have therefore used the relation between $\lambda(T)/\lambda_L(T)$ and $\xi_0/\lambda_L(T)$ obtained by Bardeen, Cooper, and Schrieffer in their theory. In addition, we have had to draw on the results of magnetization measurements and ultrasonic attenuation data, but it should be emphasized that this elaborate procedure is merely to obtain a relatively small correction.

As yet, there are no anomalous skin-effect measurements on niobium, which together with γ , the coefficient of the linear term in the electronic specific heat, would enable ξ_0 to be estimated. In the present experiments the frequency and purity of the metal were such that the skin effect was not appreciably "anomalous." It is however possible to obtain an estimate of ξ_0 . It is shown below how $\lambda_L(0)$ may be estimated. The specific heat measurements of McConville and Serin²⁰ interpreted in terms of the Abrikosov² model show that at the transition temperature, $\kappa = 0.96\lambda_L(0)/\xi_0 = 1.0$. Thus, we obtain $\xi_0 = 3.8 \times 10^{-6} \text{ cm}$. It is then possible to self-consistently invert the relation between $\lambda(T)/\lambda_L(T)$ and $\xi_0/\lambda_L(T)$ and so convert the measured value of $d\lambda(T)/dy$ into $d\lambda_L(T)/dy$.

To obtain $\lambda_L(0)$ we note that Eq. (3) can be expanded in a Taylor series in $\beta\epsilon(T)$. After carrying out a numerical integration, we get $\Lambda/\Delta_T = 0.213\beta^2\epsilon(T)^2 + [\text{terms of higher order in } \beta\epsilon(T)]$. Dobbs and Perz²¹

found from their ultrasonic attenuation measurements in niobium that near T_c ($y \geq 2.5$), $\epsilon(T) = B(1-t)^{1/2}kT_c$, where $B = 4.17 \pm 0.03$. A similar variation is predicted by the BCS theory with $B = 3.1$. We have accordingly assumed such a functional dependence of ϵ on t . Recalling that $\Lambda_T/\Lambda = [\lambda_L(T)/\lambda_L(0)]^2$ and that near T_c we have $\lambda(T) = \lambda_L(T)$, we get $\lambda(T) = \lambda_L(0)/0.213B(1-t)^{1/2}$. From the experiments we find that for $y \geq 2.5$, $\lambda(T) \propto y = (\frac{1}{2})(1-t)^{-1/2}$ so that $\lambda_L(0) = 0.213B(\frac{1}{2})(d\lambda/dy)_{T_c}$, where $(d\lambda/dy)_{T_c} = 440 \text{ \AA}$. A self-consistent analysis of our results using Eq. (3) gives $B = 3.9$, so that $\lambda_L(0) = 390 \text{ \AA}$. Using the relation between $\lambda(T)/\lambda_L(T)$ and $\xi_0/\lambda_L(T)$ of the BCS theory we get $\lambda(0) = 470 \text{ \AA}$.

B. Comparison of Experimental Results with the BCS Theory

Since the present experiments measure changes in the penetration depth, a direct comparison between theory and experiment can be made by plotting $d\lambda_L(T)/dy$ against y . Determining $d\lambda_L(T)/dy$ from $d\lambda(T)/dy$ is very insensitive to the value of $\xi_0/\lambda_L(0)$ when $\xi_0/\lambda_L(0)$ is not greater than unity. The dominant error in $d\lambda_L(T)/dy$ therefore comes from the experimental error in measuring $d\lambda(T)/dy$ which ranges from about 5% for $y > 1.5$ to about 10% at $y = 1.1$.

Figure 6 shows $d\lambda_L(T)/dy$ as a function for y for the present experiments and for the BCS theory. Also shown are results based on the energy-gap measurements of Dobbs and Perz. A value of $\lambda_L(0) = 390 \text{ \AA}$ was used in calculating all results.

In the present experiments the increase in $d\lambda/dy$ with decreasing y is greater than predicted by the BCS theory. This is in contrast to all previous measurements of the penetration depth in pure superconductors where the increase in $d\lambda/dy$ was less than predicted by the BCS theory. The slope $d\lambda/dy$ is sensitive to the energy gap in the superconductor and this fact will be

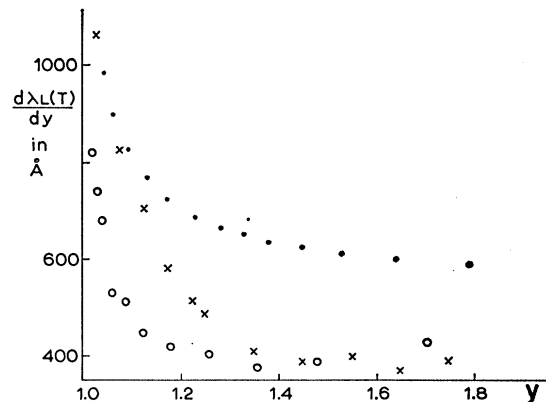

FIG. 6. $d\lambda_L(T)/dy$ as a function of y for the present results, for the results of Dobbs and Perz (DP), and for the BCS theory. All curves are based on $\lambda_L(0) = 390 \text{ \AA}$.

²⁰ T. McConville and B. Serin, Phys. Rev. Letters **13**, 365 (1964).

²¹ E. R. Dobbs and J. M. Perz, Rev. Mod. Phys. **36**, 257 (1964).

used later to deduce the variation of the energy gap of niobium with temperature.

Figure 7 shows $\lambda_L(T)/\lambda_L(0)$ as a function of y for the present experiments using $\xi_0/\lambda_L(0)=1.0$. The predictions of the BCS theory are shown also together with the incorporation of the results of Dobbs and Perz²¹ into Eq. (3), taking $2\epsilon(0)/kT_c=3.52$ and 3.75.

C. Information about the Energy Gap from the Measurements

One can deduce the qualitative behavior of the energy gap by comparing the gross features of the curves shown in Fig. 7 with Eq. (3). At low temperatures, the present results are close to the BCS curve, indicating that the energy gap at these temperatures is close to the BCS value. The present results are always on, or lower than the BCS curve which means the energy gap at any temperature is equal to or greater

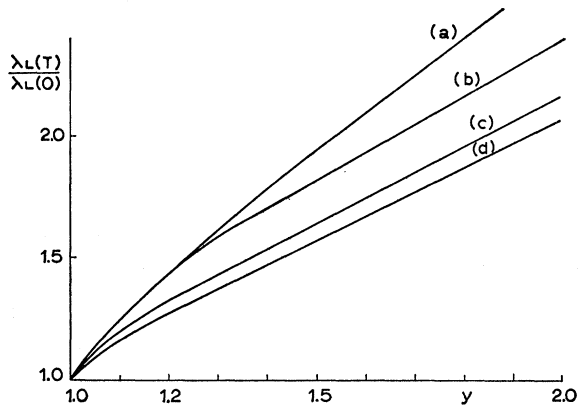

FIG. 7. $\lambda_L(T)/\lambda_L(0)$ as a function of y for: (a) the BCS theory (b) the present experiments (c) and (d) results of Dobbs and Perz for $2\epsilon(0)=3.52kT_c$ and $2\epsilon(0)=3.75kT_c$, respectively.

than the BCS value. The much smaller slope at high temperatures shows a more rapid change with temperature of the energy gap near T_c than predicted by the BCS theory.

The energy gap ratio $\epsilon(T)/\epsilon(0)$ was calculated from the experimentally determined $\lambda_L(T)/\lambda_L(0)$ by the inversion method described by Waldram¹⁰ and is shown as a function of temperature in Fig. 8 together with the values predicted by the BCS theory and those deduced from ultrasonic attenuation measurements by Dobbs and Perz.²¹ The lack of agreement between the ultrasonic and the present results may be due in part to the difficulties of allowing for the background losses in the ultrasonic experiments. Agreement may be obtained at the lower temperatures ($t < 0.45$; $y < 1.03$) by assuming that $\epsilon(0)$ is given correctly by the BCS theory instead of by $2\epsilon(0)=3.75kT_c$ as deduced by Dobbs and Perz. Both experiments then give the same value of $\epsilon(T)/\epsilon(0)$ near T_c .

The most recent tunnelling measurements of Neuge-

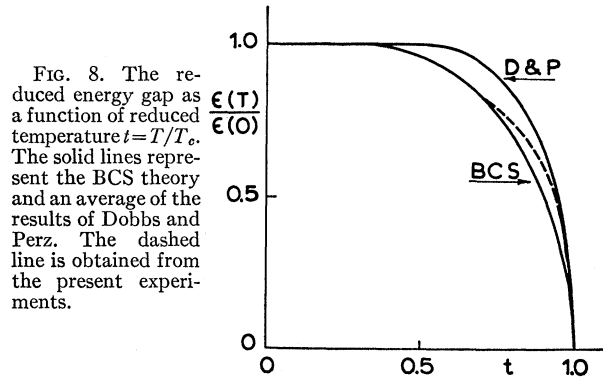

FIG. 8. The reduced energy gap as a function of reduced temperature $t=T/T_c$. The solid lines represent the BCS theory and an average of the results of Dobbs and Perz. The dashed line is obtained from the present experiments.

bauer and Ekvall²² on niobium give $2\epsilon(0)/kT_c=3.6$ which is quite different from the previous tunnelling value of $2\epsilon(0)/kT_c=3.84$ obtained by Townsend and Sutton.²³ The films of Neugebauer and Ekvall²² were evaporated in a manner so as to minimize absorption of gases which greatly affect the superconducting properties of niobium.²⁴ These films had transition temperatures characteristic of large samples of niobium, at least over a certain range of thicknesses, while Townsend and Sutton²³ did not measure the critical temperature of their films.

V. CONCLUSION

There appear to be no anomalies in the electrodynamic behavior of a type II superconductor in the absence of a strong magnetic field.

Although we have obtained estimates of the penetration depth λ (at $T=0$, $\lambda=470 \text{ \AA}$) the quantity which these experiments give most accurately is $d\lambda/dy$ in the vicinity of T_c , where the changes in frequency are relatively large and the possible errors in calibration are relatively small. Relative to the value for tin, $(d\lambda/dy)_{T_c}$ for niobium has been determined to within 5%: that is, for niobium $(d\lambda/dy)_{T_c}=(440 \pm 20) \text{ \AA}$.

The increase in $d\lambda/dy$ as y approaches unity is greater than predicted by the BCS theory. This is in contrast to all other superconductors measured previously where $d\lambda/dy$ increased less than predicted at low temperatures, but as has been shown above, agreement between the present experiments and the BCS theory can be obtained by a slight modification of the temperature dependence of the energy gap.

The question of whether the penetration depth measured at these high frequencies is the same as the static-field penetration depth is resolved by the agreement between the active method measurements carried out at 4 Mc/sec and the passive measurements at 80 Mc/sec. The reasons for this independence of frequency have been discussed previously in connection with other superconductors by Pippard.⁹

²² C. A. Neugebauer and R. A. Ekvall, J. Appl. Phys. **35**, 547 (1964).

²³ P. Townsend and J. Sutton, Phys. Rev. **128**, 591 (1962).

²⁴ W. DeSorbo, Phys. Rev. **132**, 107 (1963).

ACKNOWLEDGMENTS

We are grateful to A. C. Rose-Innes for supplying the niobium used in this investigation and to E. R. Dobbs and J. M. Perz for sending a preprint of their work. We thank H. Fenichel for assistance with the program-

ming and A. Hoornbeck and A. Siemons for help in constructing the apparatus. It is a pleasure to thank B. Serin for his continual interest in this project. We are indebted to the National Science Foundation and to the Rutgers University Research Council for financial support.

Correlation Functions for a Heisenberg Ferromagnet*

S. H. LIU

Institute for Atomic Research, Department of Physics, Iowa State University, Ames, Iowa

(Received 7 April 1965)

It is shown that the ac longitudinal susceptibility of a Heisenberg ferromagnet is proportional to the Fourier transform of a dynamical zz correlation function of the spins, z being the direction of the spontaneous magnetization. The susceptibility can also be calculated by the Tyablikov decoupling approximation. Hence, the dynamical zz correlation function is obtained by taking the inverse Fourier transform of the latter result. This expression for the correlation function is an interpolation formula which agrees with the noninteracting spin-wave theory at very low temperatures and with the statistical theory at very high temperatures. The applications of these correlation functions to specific heat, susceptibility, and electrical conductivity are also discussed.

I. INTRODUCTION

IT has been very fruitful to study the properties of ferromagnetic materials in terms of the Heisenberg model. The model consists of a regular array of localized spins that are coupled together by the so-called exchange interaction. In practice, the exchange coupling parameters are regarded as phenomenological constants whose values are determined by fitting the theory with a set of experimental results. Then one can use the model to explain other experimental results and thereby correlate a large number of related phenomena. It is clear that we must understand the statistical dynamics of the Heisenberg model in order to complete this program. This has not been entirely successful because of the mathematical difficulties in solving the model.

Considerable progress has been made toward approximate solutions of the model at high- and low-temperature regions. At temperatures very low compared with the Curie point, the normal modes of the spin system are of wave character. The dynamics of the model may be studied in terms of the spin-wave approximation.¹⁻³ At temperatures high above the Curie point, there is no long-range order and each spin interacts comparatively strongly only with its nearest

neighbors. Its interaction with other spins is progressively weaker when the latter are farther away. In this case, one can expand the partition function or the free energy into a power series of the inverse temperature.^{4,5} One can then analyze the properties of the model in the paramagnetic temperature region. The Curie point corresponds to the temperature at which the power series for the susceptibility diverges. In recent years, numerical techniques have been developed to extrapolate the power series to the region near its circle of convergence.⁶⁻⁸ This makes it possible to understand a number of critical phenomena that occur just above the Curie point.

At temperatures lower than but not negligibly small compared with the Curie point, both the above-mentioned methods of analysis fail. In this case, the Weiss molecular-field approximation⁹ or the more refined Bethe-Peierl-Weiss¹⁰ (BPW) approximation is useful. These methods ignore partly or wholly the correlation between the transverse components of the spins, and consequently, disagree with the spin-wave approximation at low temperatures. Above the Curie point, the Weiss approximation gives no short-range order.

⁴ W. Opechowski, *Physica* **4**, 181 (1937).

⁵ G. S. Rushbrooke and P. J. Wood, *Proc. Phys. Soc. (London)* **A70**, 765 (1957); *Mod. Phys.* **1**, 257 (1958).

⁶ C. Domb and M. F. Sykes, *J. Math. Phys.* **2**, 63 (1961); *Phys. Rev.* **128**, 168 (1962).

⁷ G. A. Baker, *Phys. Rev.* **124**, 768 (1961); **129**, 99 (1963).

⁸ J. Gammel, W. Marshall, and L. Morgan, *Proc. Roy. Soc. (London)* **A275**, 257 (1963).

⁹ P. Weiss, *J. Phys.* **6**, 667 (1907).

¹⁰ P. R. Weiss, *Phys. Rev.* **74**, 1493 (1948).

* Contribution No. 1691. Work was performed in the Ames Laboratory of the U. S. Atomic Energy Commission.

¹ T. Holstein and H. Primakoff, *Phys. Rev.* **58**, 1098 (1940); see also C. Kittel, *Quantum Theory of Solids* (John Wiley & Sons, Inc., New York, 1964), Chap. 4.

² F. J. Dyson, *Phys. Rev.* **102**, 1217 (1956).

³ F. Keffer and R. Loudon, *J. Appl. Phys.* **32**, 2S (1961).