

Decay of Au^{195†}

J. R. HARRIS, G. M. ROTHBERG, AND N. BENCZER-KOLLER

Department of Physics, Rutgers, The State University, New Brunswick, New Jersey

(Received 16 December 1964)

The decay of Au¹⁹⁵ has been re-examined by gamma-ray spectroscopy techniques in order to obtain a more reliable value of the internal conversion coefficient α of the 99-keV ground-state transition. Au¹⁹⁵ decays by electron capture to the ground state of Pt¹⁹⁵ and to the first three excited states at 99, 130, and 210 keV. The relative-decay branching ratios to these states are $(13 \pm 10)\%$, $(47 \pm 6)\%$, $(40 \pm 6)\%$, and $<0.04\%$, respectively. The decay energy $W_0 = (222 \pm 5)$ keV was determined from the observed L/K capture ratios. Four gamma rays are present in the decay with energy and relative intensity: 31 keV (12%), 99 keV (100%), 130 keV (7.7%), and 210 keV (0.25%). The K internal conversion coefficient α_K of the 99-keV ground-state transition is $\alpha_K = 5.9 \pm 0.6$ which, together with the experimental result $\alpha_K/(\alpha_L + \alpha_M) = 4.7$ of de-Shalit *et al.*, yields a value for the total internal-conversion coefficient $\alpha = 7.2 \pm 0.7$. Finally, the half-life of the 99-keV state was determined from the measurement of the linewidth in the recoilless-absorption spectrum of the 99-keV radiation: $\tau_{1/2} = (1.7 \pm 0.2) \times 10^{-10}$ sec.

I. INTRODUCTION

THE decay scheme of Au¹⁹⁵ and the low-lying levels of Pt¹⁹⁵ are shown in Fig. 1. Previous electron spectrometer and gamma-ray scintillation spectroscopy¹⁻⁵ studies of Au¹⁹⁵ and of the isomer Pt^{195m}, and Coulomb excitation measurements⁶ on Pt¹⁹⁵ yielded precise energy measurements as well as unambiguous multipolarity assignments for the four gamma rays.

Some very early studies indicated a 31-keV ground-state transition preceded by a 99-keV transition. The nonexistence of this 31-keV state was confirmed by the latest Coulomb excitation⁶ data and by the present investigation.

Therefore the level scheme seems firmly established, and the spin and parity assignments seem uniquely determined by the experimental data from Coulomb excitation and by the very precise measurements of the energy and relative intensity of the internal-conversion electron lines. Nonetheless there exists considerable spread: (a) in the various determinations of the four possible electron-capture transition energies, relative transition probabilities, and L -to- K capture ratios, (b) in the relative gamma-ray intensities, and (c) in the internal conversion coefficients for the radiative transitions. The K conversion coefficient α_K for the 99-keV transition has been determined by three groups and the following results were obtained: $\alpha_K = 5.8 \pm 1.5$,⁶ $\alpha_K = 7.4_{-2.8}^{+8.2}$,¹ $\alpha_K = 8.4 \pm 0.5$,⁵ with $\alpha_K/\alpha_L = 5.8 \pm 0.3$,¹ $\alpha_L/\alpha_M = 4.3$,¹ and $\alpha_L/\alpha_{M1} = 4.5$.⁴ It is unfortunate that such uncertainty is present in the value of α since this

quantity enters in a sensitive way into the derivation of the Debye-Waller factor for platinum metal as obtained from the analysis of the recoilless emission and absorption of the 99-keV transition.⁷ It was mainly to determine this conversion coefficient that the present investigation was undertaken and the decay scheme of Au¹⁹⁵ was re-examined. Most of the measurements were carried out with standard scintillation spectrometers and coincidence circuits except for the lifetime of the 99-keV state which was determined by Mössbauer absorption.

II. APPARATUS AND MEASUREMENTS

A. γ -Ray Spectra and Coincidence Measurements

The scintillation counters used for these experiments were 1.5-in.-diam by 2-in.-thick NaI(Tl) detectors

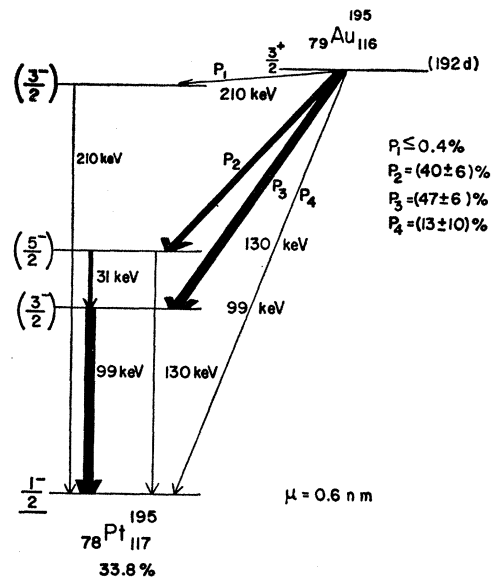

FIG. 1. Decay scheme of Au¹⁹⁵.

⁷ J. R. Harris, G. M. Rothberg, and N. Benczer-Koller, Phys. Rev. (to be published).

† This work was supported by the National Science Foundation.

¹ A. de-Shalit, O. Huber, and H. Schneider, *Helv. Phys. Acta* **25**, 279 (1952); L. P. Gillon, K. Gopalakrishnan, A. de-Shalit, and J. W. Mihelich, *Phys. Rev.* **93**, 124 (1954).

² J. M. Cork, M. K. Brice, L. C. Schmid, G. D. Hickman, and H. Nine, *Phys. Rev.* **94**, 1218 (1954).

³ V. R. Potnis, C. E. Mandeville, and J. S. Burlew, *Phys. Rev.* **101**, 753 (1956).

⁴ P. J. Cressman and R. G. Wilkinson, *Phys. Rev.* **109**, 872 (1958).

⁵ A. Bisi, E. Germagnoli, and L. Zappa, *Nuovo Cimento* **11**, 843 (1959).

⁶ F. K. McGowan and P. H. Stelson, *Phys. Rev.* **116**, 154 (1959).

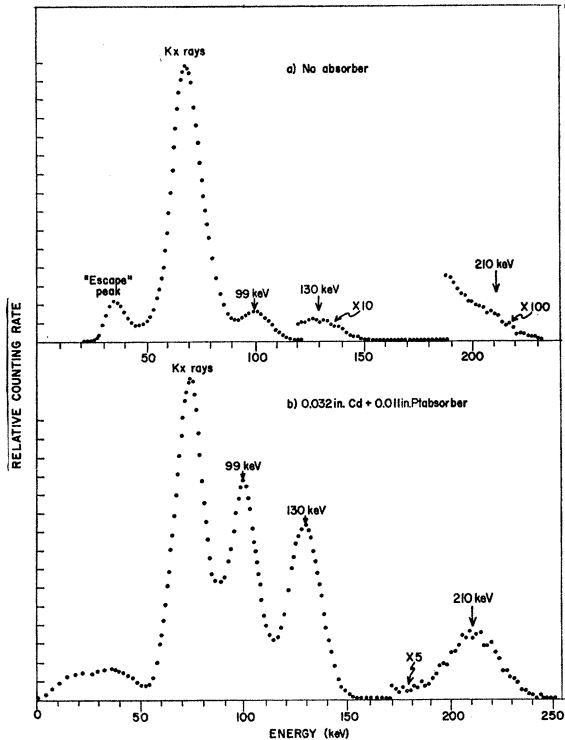

FIG. 2. Gamma-ray scintillation spectra measured with a 1.5-in. \times 2-in. NaI(Tl) crystal. The source detector distance was 40 cm. The background count has been subtracted before plotting. (a) Spectrum taken with no absorber between source and detector. (b) Spectrum observed with 0.032-in. Cd and 0.011-in. Pt absorbers placed over the crystal.

mounted on RCA-6342 photomultipliers. These counters were followed by amplifiers, single-channel pulse-height analyzers, a fast-slow coincidence circuit with a resolving time $\tau \approx 80$ nsec and a multichannel analyzer.

The measurements of the scintillation spectra were carried out with considerable precautions to avoid scattering with small energy loss of the low-energy radiations by the surroundings into the detectors, and to avoid pileup at 130 and 210 keV due to simultaneous detection of two or more x rays. Pileup was prevented by using weak sources and large source-detector distances. The absence of pileup was further verified by additional measurements of the scintillation spectra with Au, Sn, or Cd absorbers. A typical spectrum with no absorber is shown in Fig. 2(a), while a spectrum taken with 0.032 in. of Cd and 0.011 in. of Pt is displayed in Fig. 2(b). Five peaks are evident; of these, four correspond to the gamma-ray transitions at 31, 99, 130, and 210 keV and the fifth corresponds to platinum K x rays. The latter are a composite of the various $K\alpha_1$ (66.8 keV), $K\alpha_2$ (65.1 keV), $K\beta_1$ (75.8 keV), $K\beta_2$ (77.9 keV), $K\beta_3$ (75.4 keV), $K\beta_4$ (77.8 keV), and $K\beta_5$ (76.2 keV) lines with relative intensities $K\alpha_1$:

$K\alpha_2$: $K\beta_1$: $K\beta_2$ = 100: 54.7: 34.4: 9, where $K\beta_1 = K\beta_1 + K\beta_3 + K\beta_5$ and $K\beta_2 = K\beta_2 + K\beta_4$.⁸

Only a fraction of the line at ~ 35 keV in Fig. 2(a) consists of 31-keV gamma rays. The main contribution to this peak stems from platinum x rays stopping in the crystal and the iodine K x rays escaping. In order to determine this fraction, the absorption of this line by copper was measured. Indeed, for absorbers of thickness > 0.25 gm/cm², an exponential absorption curve was observed corresponding to an absorption coefficient $\mu = 1.06$ cm²/gm as expected for the composite x radiation. By extrapolating the straight portion of the absorption curve to zero thickness and subtracting it from the actual counting rate, the 31-keV contribution can be isolated. The absorption coefficient thus obtained for the 31-keV gamma rays was $\mu = (10.0 \pm 2.0)$ cm²/gm in good agreement with the expected value, and the fraction of 31-keV gamma rays in the peak was $(8 \pm 1)\%$.

This result was checked by comparing the relative intensities under the peak at ~ 35 keV and under the x ray peak as measured in two experiments, one with no absorber between source and detector, and the other one with a 0.030-in. copper absorber. In this last situation the 31-keV gamma ray is completely absorbed, and only the escape peak remains. The fraction of 31-keV gamma rays in the low-energy peak was determined by this method to be $(8.4 \pm 1.0)\%$, and an average value of $(8.2 \pm 0.7)\%$ was used as the final result.

Figure 3 shows the spectrum obtained with a proportional counter filled with slightly more than one atmosphere of an argon (90%)–methane (10%) mixture, and through a 0.005-in. Mylar window. The 31-keV line is clearly resolved, and the x ray peak is now split into the $K\alpha$ and $K\beta$ components.

The gamma spectrum was also observed with a Ge-Li

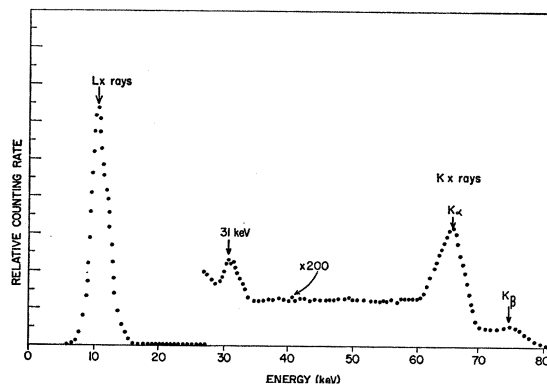

FIG. 3. Gamma-ray spectrum measured with an argon (90%)–methane (10%) proportional counter. The background count has been subtracted before plotting.

⁸ A. H. Wapstra, G. J. Nijgh, and R. van Lieshout, *Nuclear Spectroscopy Tables* (North-Holland Publishing Company, Amsterdam, 1959).

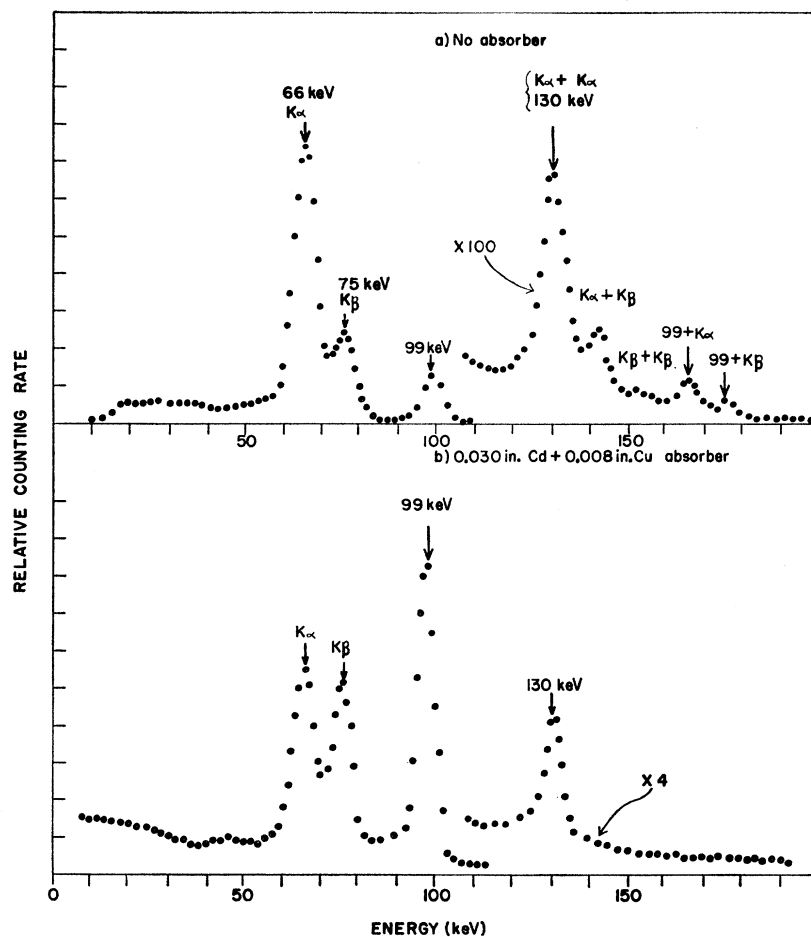

FIG. 4. (a). Gamma-ray spectrum obtained with a Ge Li-drifted counter of 3-cm² area and 0.5-cm depth, and no absorber between the source and the detector. All lines of energy greater than 130 keV can be explained qualitatively and quantitatively by pileup between various low-energy radiations as indicated above each peak. (b). Gamma-ray spectrum obtained under the same geometry conditions but with 0.030-in. Cd and 0.008-in. Cu absorbers. All the pileup peaks have thus been eliminated. In both spectra the background count has been subtracted before plotting.

drifted counter.⁹ Figure 4(a) shows the spectrum obtained without any absorber, while Fig. 4(b) shows the results obtained with 0.030-in. cadmium and 0.008-in. copper absorbers which prevent pileup. Again, the $K\alpha$ and $K\beta$ lines are clearly resolved and so are the 99- and 130-keV gamma rays. However, all lines of energy $E > 130$ keV seen in Fig. 4(a) disappear from the spectrum in Fig. 4(b) and can be easily explained qualitatively and quantitatively in terms of pileup of the various x rays among themselves or with the 99-keV transition as is shown in the figure. The 210-keV line is too weak to be seen on this scale. No γ rays other than the ones already discussed appear in the spectrum.

The coincidence measurements were carried out by displaying, on a multichannel analyzer, the spectrum in coincidence with a particular radiation selected by the single-channel analyzer of detector No. 1. Three sources were used for these measurements, of about 4, 6, and 16 mCi. The weakest source was made by depositing some Au^{195} on a 0.001-in.-thick Mylar foil, the

other two by evaporating Au^{195} on a 0.001-in. platinum foil. The sources were placed at distances varying between 2.5 and 5.0 cm from either counter. The ratio of true to accidental coincidences varied in the worst case from about 10 for coincidences with the 130-keV gamma ray to 15 and 30 for coincidences with the 99-keV gamma rays and with the K x rays, respectively. Accidental coincidences were always subtracted from all coincidence spectra. All coincidence experiments were performed twice; first in the geometry described above, and second with a 0.030-in. copper foil in front of counter No. 1 to prevent "cross-talk" between the counters. The results of all sets of experiments agreed within their statistical errors and were therefore averaged. Typical coincidence spectra are shown in Fig. 5.

It was the purpose of this investigation to determine experimentally the following quantities: P_1, P_2, P_3, P_4 and $P_1^K/P_1, P_2^K/P_2, P_3^K/P_3, P_4^K/P_4$ where the P_i are the relative transition probabilities for decay of Au^{195} by electron capture to the four lowest states of Pt^{195} subject to the condition $\sum_{i=1}^4 P_i = 1$, and the P_i^K/P_i are the ratio of K to total capture for each branch; P_{co}^{130} , the probability of crossover transition

⁹ The authors are greatly indebted to Dr. K. Jones, Dr. C. Chasman, and Dr. R. A. Ristinen for making their Ge counter available and for measuring the gamma-ray spectra. The detector used for this experiment was 3 cm² in area by 0.5 cm thick.

FIG. 5. Gamma-ray spectrum in coincidence with (a) the x rays, (b) the 99-keV gamma ray, (c) the 130-keV gamma ray. For this last measurement a 0.032-in. Cd absorber was placed between the source and the triggering detector to prevent the 130-keV pileup of two *K* x rays from triggering the detector.

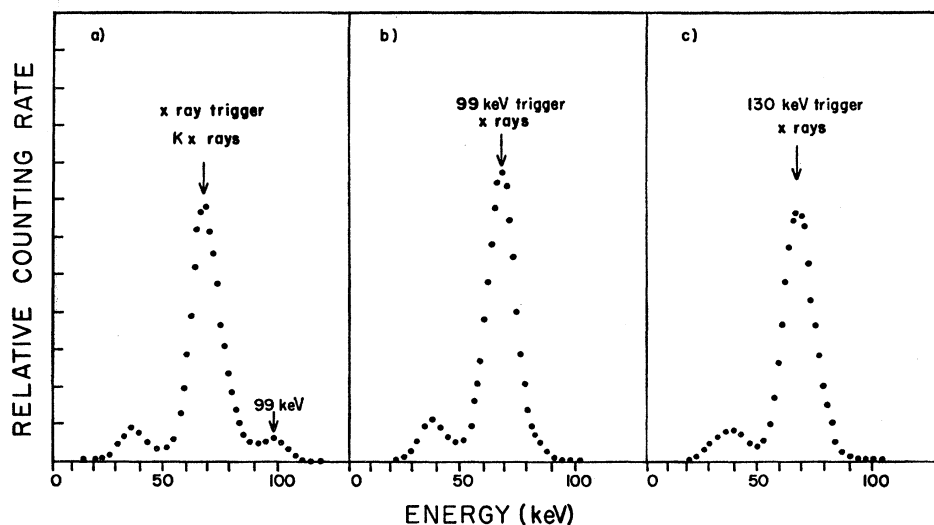

from the 130-keV state to ground; and α_j and α_{Kj} , the total and *K* internal conversion coefficients of the particular transition of energy denoted by the subscript *j*. Furthermore the absolute source strength N_0 , although of no general interest, appears in all expressions and must be considered as another unknown. Since it is possible to perform only seven significant, independent single and coincidence measurements, it becomes necessary to rely on theoretical predictions for some of the quantities listed. It turns out that $P_1^K/P_1=0$ because there is not enough energy available for *K* capture in that branch, and P_2^K/P_2 , P_4 and P_{co}^{130} are extremely small and only enter as a correction of the order of a few percent in the determination of α_{K99} , P_2 and P_3 . Furthermore α_{K130} , α_{130} , and α_{31} only appear in expressions multiplying P_{co}^{130} or P_2^K/P_2 . Therefore the theoretical values¹⁰ for these conversion coefficients $\alpha_{31}=34.2$, $\alpha_{K130}=0.46$, and $\alpha_{130}=1.75$ were used, assuming the 31-keV transition to be pure *M1*, and the 130-keV transition to be pure *E2*. These assumptions are justified by the experimental (M_I/M_{II}) ratio for the 31-keV transition and by the value of $(L_I+L_{II})/L_{III}$ of the 130-keV transition as determined by Cressman and Wilkinson.⁴ The experimental value $\alpha_K/(\alpha_L+\alpha_M)=4.7$ of de-Shalit *et al.*¹ for the ratio of the 99-keV transition conversion coefficients was used. This value is in excellent agreement with the theoretical value of 4.6.¹⁰

A sketch of how the seven independent measurements described above were used to extract information is given below; the exact expressions relating the unknown parameters to the measured quantities are given in the Appendix. In what follows N_i^j will be used to denote the number of photons of energy *i* in counter No. 2 in coincidence with photons of energy *j* triggering counter

No. 1. N_k represents the number of photons of energy *k* detected in a given counter. First P_{co}^{130} was determined from the relative intensities N_{130} and N_{31} of the 130- and 31-keV gammas. Then from the ratio N_x^{130}/N_{130} of x rays in coincidence with 130-keV gammas to the number of 130-keV gammas triggering counter No. 1, the ratio P_2^K/P_2 was established. This particular experiment was performed with 0.032 in. of cadmium absorber in front of counter No. 1 to prevent pileup of two x rays appearing as a 130-keV gamma and giving rise to a false number both of singles and of coincidences.

The third experiment determines the ratio N_x^x/N_{99}^x which is proportional to $\alpha_{K99}(1+A)$. *A* is an extremely small term containing the ratio $(P_2^K/P_2)P_{co}^{130}$ multiplied by other parameters of the decay not yet determined. However, it turns out that these are of the order of unity, and *A* is of the order of 0.26%. Hence, as a first approximation *A* can be neglected in α_{K99} in order to determine these other parameters, and will be reintroduced later in the final determination of α_{K99} . The fourth and fifth experiments yield the ratios N_{99}/N_{130} and N_x^{99}/N_{99} and therefore P_3/P_2 , P_3^K/P_3 and the correction factor *A*. From the ratio N_x/N_{130} together with the theoretical estimate for P_4^K/P_4 , the ratio P_4/P_2 will be determined.

P_4^K/P_4 was taken from theoretical predictions of Brysk and Rose¹¹ who have calculated *L/K* capture ratios as a function of energy. These ratios increase very slowly with decreasing capture energy until the neighborhood of the threshold, at which point they become infinite. If the Wapstra *et al.* estimate $L/(M+N+\dots)=3.79$ for the capture ratio for $Z=78$ is used,⁸ $P_2^L/P_2^K=(5.1\pm 0.2)$ and $P_3^L/P_3^K=(1.12\pm 0.30)$ are obtained. These ratios indicate transfer energies¹¹ for the P_2 and P_3 branches of (92 ± 5) keV and (115 ± 30) keV, respectively, and hence a total decay energy $W_0=(225+5)$ keV for the P_4 branch to the ground state of Pt¹⁹⁵. For

¹⁰ L. A. Sliv and I. M. Band, Reports Nos. 57ICCKI and 58ICCLL, Physics Department, University of Illinois, 1957-1958 (unpublished).

¹¹ H. Brysk and M. E. Rose, Rev. Mod. Phys. **30**, 1169 (1958).

TABLE I. Summary of results and comparison with previous experimental and theoretical work.

	P_1	P_2	P_3	P_4	P_2^K/P_2	P_3^K/P_3	W_0 (keV)	
This work	<0.004	0.40 ± 0.06	0.47 ± 0.10	0.13 ± 0.15	0.13 ± 0.01	0.40 ± 0.09	(222 ± 5)	
Bisi <i>et al.</i> ^a	0	0.50	0.50	0	0.154 ± 0.021	...	236	
	P_{co}^{130}	I_{31}	I_{99}	I_{130}	I_{210}	α_{K99}	$[\alpha_K/(\alpha_L+\alpha)]_{99}$	α_{99}
This work	$(5.2\pm 1.0)\%$	12.3 ± 1.8	100	7.7 ± 0.8	0.25 ± 0.03	5.9 ± 0.7		7.2 ± 0.7
Bisi <i>et al.</i> ^a		...	100	7.4	...	8.4 ± 0.5		
McGowan and Stelson ^b	10%					5.8 ± 1.5		
de-Shalit ^c						$7.4^{+8.2}_{-2.8}$	4.7	
Sliv ^d						$5.7(M1)$	4.6	$6.9(M1)$
						$0.69(E2)$	0.16	$5.0(E2)$

^a Reference 5.
^b Reference 6.

^c Reference 1.
^d Reference 10.

this energy Brysk and Rose give $P_4^K/P_4=0.71\pm 0.01$. N_{210}/N_{130} yields a value for P_1 whose upper limit depends upon the conversion coefficient α_{210} , and upon the minimum value of the crossover to cascade ratio for de-excitation of the 210-keV state. A minimum value $P_{co}^{210}=0.1$ was chosen for the cross-over probability. The angular correlation results of McGowan and Stelson yield a ratio $\delta=(E2/M1)^{1/2}=(0.37\pm 0.02)$ for the multipolarity of this transition and therefore a theoretical conversion coefficient $\alpha_{210}=0.77$. Finally, from the condition $\sum_{i=1}^4 P_i=1$, the absolute values of the P_i are settled.

There are six geometrical factors, the efficiencies for the five radiations under study and the solid angle that have not yet been taken into account. The product of the efficiency and solid angle were taken from the calculated values of Wolicki, Jastrow, and Brooks.¹² In general, these might differ somewhat from the actual values of the efficiencies. However, since the radiations in this problem are of relatively low energy and the crystals are large, the efficiencies for the four lowest energy radiations fall within 7% of unity. Furthermore in all expressions of major interest, and in particular in the expression yielding α_{K99} , ratios of efficiencies appear, and these ratios are likely to be much more reliable than the absolute values. The efficiencies of Wolicki *et al.* were corrected to account for the absorption of the incident radiation in the aluminum case surrounding the NaI(Tl) crystal and the Al₂O₃ reflector within the case. This correction is appreciable only for the 31-keV gamma rays. The transmissions T through the case for the five radiations were $T(31 \text{ keV}): T(x \text{ rays}): T(99 \text{ keV}): T(130 \text{ keV}): T(210 \text{ keV})=74\% \pm 7\%: 93\% \pm 5\%: 94\% \pm 5\%: 95\% \pm 5\%$. The fluorescence yield $\omega_K=0.952$ was obtained from the measurements of Hagedoorn and Wapstra.¹³

¹² E. A. Wolicki, R. Jastrow, and F. Brooks, National Research Laboratory Report 4833, 1956 (unpublished).

¹³ H. L. Hagedoorn and A. H. Wapstra, Nucl. Phys. **15**, 146 (1960).

The results of these experiments and of some of the previous experiments and theoretical estimates are listed in Table I. The errors quoted contain several contributions besides the statistical errors: a 5% error due to the uncertainty in the detector efficiency was included in results where the efficiency appears as an absolute quantity, while only a 2% error was assigned to efficiency ratios; and a 10% error due to the difficulty in determining the relative intensity of the five radiations from the scintillation spectra.

B. Mössbauer Absorption Measurements

a. 99-keV Transition

The recoilless resonance absorption of the 99-keV transition was studied and described in detail in a previous publication.⁷ From these studies, the width of the resonance line and hence a lower limit on the lifetime of the 99-keV state were determined. The observed half-life $\tau_{1/2}=(1.7\pm 0.2)10^{-10}$ sec is in good agreement with the only electronic measurement $\tau_{1/2}\sim 1.4\times 10^{-10}$ sec.¹⁴

b. 31-keV Transition

The Mössbauer resonance absorption at 20°K of a possible 31-keV ground-state transition by a 0.001-in. platinum absorber should be of the order of 61%. After correction for the large ratio of escape radiation to 31-keV gamma rays detected in a NaI(Tl) crystal, and for resonant self-absorption in the source, the effect should be reduced to 1.5%. No Mössbauer absorption line was observed of magnitude greater than 0.3% and of width ranging between 3.2×10^{-6} eV and 0.2×10^{-6} eV corresponding to a half-life 3×10^{-10} sec $\leq \tau_{1/2} \leq 5.4\times 10^{-9}$ sec. The absence of resonance absorption of the 31-keV transition confirms the McGowan and Stelson Coulomb excitation data and supports the proposed level scheme for Pt¹⁹⁵.

¹⁴ A. E. Blaugrund, Phys. Rev. Letters **3**, 226 (1959).

c. 130-keV Transition

The expected Mössbauer effect at 20°K for the 130-keV ground-state transition and the thickest absorber that could conveniently be used in this experiment (0.011 in.) would be about 0.75% if precautions are taken to avoid pileup. For this purpose a 0.032-in. cadmium absorber which reduced the x ray intensity by a factor of 10 with respect to the 130-keV intensity was used in these runs. These experiments were also designed to cover a possible range of half-lives for the 130-keV state between 1.3×10^{-10} and 14.5×10^{-10} sec. Again no effect was observed outside the statistical error of 0.2%. Another type of experiment was carried out with the source and the 0.011-in. platinum absorber rigidly clamped together. The complete gamma spectrum was displayed on the multichannel analyzer. The source-absorber temperature was alternated every 30 min between 20 and 65°K and the total counting rates N of the x rays, the 99- and the 130-keV photons were determined for each temperature. The Mössbauer effect in this case is given by $[N(65^\circ\text{K}) - N(20^\circ\text{K})]/N(65^\circ\text{K})$. The observed effect for the three transitions were $(-0.014 \pm 0.014)\%$, $(5.23 \pm 0.04)\%$, and $(0.26 \pm 0.05)\%$, respectively, to be compared with expected effects of 0, $(5.1 \pm 0.2)\%$ and $(0.75 \pm 0.2)\%$ (Fig. 6).

It is somewhat difficult to understand why the Mössbauer effect for the 130-keV gamma ray is so small. It is possible that the Debye-Waller factor of the source, which even for the 99-keV transition was considerably smaller than that for the absorber, is even smaller for the 130-keV transition; this effect may be due to imperfections in the source, or may be related to the recoil effects following the electron capture decay of the Au¹⁹⁵ source. Another possible explanation in terms of a mixing in the detector of the 130-keV ground-state transition with another nonresonant gamma ray of approximately the same energy is entirely ruled out by the purity of the gamma spectrum in the Ge counter.

III. DISCUSSION

As can be seen from the results listed in Table I, the present experiments yield a decay scheme for Au¹⁹⁵ essentially in agreement with former work. The main differences are that the electron-capture decay energies are somewhat smaller than those determined by Bisi *et al.*,⁵ there are small but non-negligible electron-capture branches to the ground and the third excited state, the cross-over branch from the second excited state is about half of what was assumed previously, and α_{K99} was determined with higher precision than previously.

The $\log ft$ values of the K capture transitions to the ground state and the first two excited states are 7.7, 7.4, and 8.1, respectively, in agreement with $\log ft$ values of first forbidden, nonunique transitions, and

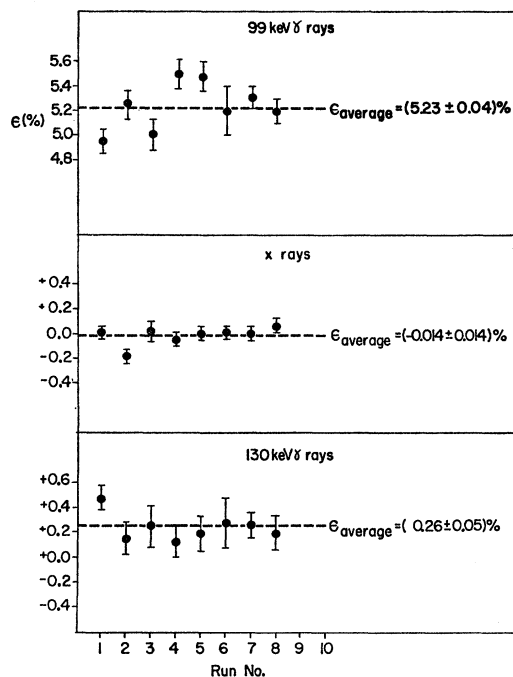

FIG. 6. Plot of the magnitude of the Mössbauer effect $[N(65^\circ\text{K}) - N(20^\circ\text{K})]/N(65^\circ\text{K})$ for the x rays and the 99- and 130-keV gamma rays, measured in consecutive runs of approximately 4 h each.

therefore are consistent with the spin and parity assignments.

The fact that P_{00}^{180} is only half of what was assumed by McGowan and Stelson⁶ in their Coulomb excitation studies implies that the half-life of the 130-keV state as deduced from the observed $B(E2)$ parameter becomes $\tau_{1/2} \approx (1.1 \pm 0.1) \times 10^{-9}$ sec instead of the 5.50×10^{-10} sec quoted in their paper.

The present value $\alpha_K = 5.9 \pm 0.7$ of the K internal conversion coefficient agrees well with the McGowan and Stelson⁶ measurement $\alpha_K = 5.8 \pm 1.5$, and with the theoretical value for a mixed $M1(98.6\%) + E2(1.4\%)^4$ transition, $\alpha_K = 5.9$, thus confirming the multipolarity of this transition. The total internal conversion coefficient $\alpha = 7.2 \pm 0.7$ was evaluated from the above value of α_K and the experimental ratio $\alpha_K/(\alpha_L + \alpha_M) = 4.7$.¹ The importance of this parameter in the study of the temperature dependence of the Mössbauer effect and hence of the Debye-Waller factor in platinum was discussed in detail in the previous publication.⁷

ACKNOWLEDGMENT

We wish to express our gratitude to S. Brawer who helped us extensively during the latter part of the experiment with the data collection and who wrote the computer programs for the analysis of the Mössbauer results.

APPENDIX

The relevant information about the decay of Au¹⁹⁵ is contained in P_i , P_i^K/P_i , P_{co} , and α_{K99} . These quantities are related to the experimental singles and coincidence rates N_k and N_i^j by the equations listed below.

$$N_{130}/N_{31} = [P_{co}^{130}/(1-P_{co}^{130})][(1+\alpha_{31})/(1+\alpha_{130})][\epsilon_{130}/\epsilon_{31}], \quad (A1)$$

$$N_x^{130}/N_{130} = (P_2^K/P_2)\epsilon_x\Omega_2\omega_K, \quad (A2)$$

$$N_x^x/N_{99}^x = 2\alpha_{K99}[\epsilon_x/\epsilon_{99}][1+A], \quad (A3)$$

$$A = \frac{(P_2^K/P_2)P_{co}^{130}[\alpha_{K130}/(1+\alpha_{130})][(1+\alpha_{99})/\alpha_{K99}]}{(P_2^K/P_2)(1-P_{co}^{130}) + (P_3^K/P_3)(P_3/P_2)},$$

$$N_{99}/N_{130} = [(1-P_{co}^{130})/P_{co}^{130} + P_3/P_2 P_{co}^{130}][(1+\alpha_{130})/(1+\alpha_{99})][\epsilon_{99}/\epsilon_{130}], \quad (A4)$$

$$N_x^{99}/N_{99} = [(1-P_{co}^{130})(P_2^K/P_2) + (P_3^K/P_3)(P_3/P_2)]\epsilon_x\Omega_2\omega_K/[(1-P_{co}^{130}) + P_3/P_2], \quad (A5)$$

$$N_x/N_{130} = [P_2^K/P_2 + P_{co}\alpha_{K130}/(1+\alpha_{130}) + (1-P_{co}^{130})\alpha_{K99}/(1+\alpha_{99}) + P_3/P_2 [P_3^K/P_3 + \alpha_{K99}/(1+\alpha_{99})] \\ + (P_4^K/P_4)(P_4/P_2)]\omega_K(\epsilon_x/\epsilon_{130})(1+\alpha_{130})/P_{co}^{130}, \quad (A6)$$

$$N_{210}/N_{130} = [(P_1/P_2)(P_{co}^{210}/P_{co}^{130})][(1+\alpha_{130})/(1+\alpha_{210})](\epsilon_{210}/\epsilon_{130}). \quad (A7)$$

In all these expressions it was assumed that the 130-keV state is formed mainly in the decay of Au¹⁹⁵ via the P_2 branch. This assumption is justified by the fact that within this approximation $P_1/P_2 \leq 10^{-2}$ for $P_{co}^{210} \geq 0.1$.

B¹¹(d, p)B¹² Angular Distributions at $E_d = 5.5$ MeV for the B¹² 2.62- and 2.72-MeV Levels

A. GALLMANN, F. HIBOU, AND P. FINTZ
Institut de Recherches Nucléaires, Strasbourg, France

AND

P. E. HODGSON AND E. K. WARBURTON*
Nuclear Physics Laboratory, Oxford, England
and
Institut de Recherches Nucléaires, Strasbourg, France
(Received 18 December 1964)

The angular distributions of the B¹¹(d, p) B¹² reaction leading to the 0.95-, 1.67-, 2.62-, 2.72-MeV levels of B¹² were measured at an incident deuteron energy of 5.5 MeV. The angular distribution of the elastically scattered deuterons from B¹¹ was also measured. The results were analyzed both by Butler theory and by zero-range distorted-wave Born-approximation calculations. The orbital angular momentum transferred in the reaction was determined to be $l_n = 1, 0, 0$, and (1) for these states of B¹². Some B¹¹($d, p\gamma$) B¹² measurements were made. The results for the decay of the 1.67-, 2.62-, and 2.72-MeV states were consistent with previous work. The 3.39-MeV level of B¹² was found to have a partial width for gamma decay which is less than 10% of the total width. The level structure of B¹² is compared with the spectrum of C¹² above 15-MeV excitation. Recent B¹¹(d, p) B¹² angular-distribution measurements of Mingay are used to analyze Doppler-shift measurements of Warburton and Chase for the B¹² 1.67- and 2.62-MeV levels. The result is limits of less than 10⁻¹³ sec on the mean lifetimes of both states.

I. INTRODUCTION

THERE have been numerous investigations¹⁻⁸ of the angular distributions of the B¹¹(d, p)B¹² reaction ($Q = 1.145$ MeV) leading to various bound states

of B¹². The angular distributions for the ground state and first two excited states in the energy region investigated are all indicative of a direct reaction mechanism and have been analyzed by either the plane-wave Born

* National Science Foundation senior postdoctoral fellow, 1963-4. Permanent address: Brookhaven National Laboratory, Upton, New York.

¹ J. R. Holt and T. N. Marsham, Proc. Phys. Soc. (London) **A66**, 1032 (1953).

² S. Gorodetzky, A. Gallmann, P. Fintz, and G. Bassompierre, J. Phys. Radium **22**, 573 (1961).

³ S. Gorodetzky, P. Fintz, and A. Gallmann, Compt. Rend. **255**, 879 (1962).

⁴ J. P. F. Sellschop (private communication); D. W. Mingay, thesis, University of the Witwatersrand, Johannesburg, 1964 (unpublished).

⁵ D. J. Pullen, D. H. Wilkinson, and A. B. Whitehead, *Proceedings of the Rutherford Jubilee International Conference, Manchester*,