

Melting and High-Temperature Electrical Resistance of Gold under Pressure*

DANIEL L. DECKER† AND HOWARD B. VANFLEET

Brigham Young University, Provo, Utah

(Received 2 November 1964)

The electrical resistance of gold was measured over the temperature range 30°C to the melting point and over a pressure range 0–70 kbar. At constant pressure, a sudden twofold increase in resistance sharply indicated the melting point and was used to determine the solid-liquid phase line to 70 kbar. The experimental melting curve has an initial slope, 5.91°C/kbar, in very good agreement with Clapeyron's equation, and has a form satisfying a Simon's equation with a coefficient $c=2.2\pm 0.1$. The electrical resistance data show a decrease in the temperature coefficient of resistivity at higher pressures, while the resistance at the melting point appears to be a constant independent of pressure.

I. INTRODUCTION

IN many high-pressure high-temperature experiments it would be convenient to use the electrical resistance of a material as an indication of its temperature. There have been occasions where the resistance of noble metals has been used for this purpose.^{1,2} In these cases it was assumed that the increase of resistance with temperature is independent of pressure; thus measurements at atmospheric pressure were used as the temperature calibration. One object of this experiment is to determine the temperature dependence of the electrical resistance of gold as a function of pressure. Resistance measurements were made from room temperature to the melting point for the pressure range 0–70 kbar. At the melting point there is an abrupt resistance increase; thus the melting temperature was also determined as a function of pressure.

Gold is ideal for this type of study. First it is chemically inert which is of prime importance to the experimentalist, for in high-pressure studies the materials are in intimate contact with their surroundings. The electronic and thermodynamic properties of gold however give rise to more fundamental reasons for studying this material. The conduction electrons in gold behave as nearly free electrons with an isotropic effective mass and there are no isomorphic phase transitions to pressures as high as 100 kbar.³ Thus one might expect the resistance and melting curves to be accurately represented by a simple semiclassical model of an ideal metal.

1. Electrical Resistance

The theory of the electrical resistance of metals at atmospheric pressure has met with considerable success,⁴ especially for metals in which the Fermi surface is nearly spherical and lies entirely within one Brillouin

zone. The extension of this theory to the range of high pressures is discussed by Lawson.⁵ In the region where the temperature is greater than approximately twice the Debye temperature θ , one can write a simple expression for resistance as a function of pressure P and temperature T . Starting from a formula for the pressure coefficient of resistance, derived by Lennsen and Michels⁶ for nearly free electrons, we arrive at the equation

$$R(P,T) = CT[V(P,T)]^{2\gamma-4/3}, \quad (1)$$

where C is a constant, $V(P,T)$ is the volume and γ is the Grüneisen constant. We now define the ratio

$$r_p(T, T_0) \equiv R(P, T)/R(P, T_0) \\ = T/T_0 [V(P, T)/V(P, T_0)]^{2\gamma-4/3}. \quad (2)$$

The accuracy of this equation at atmospheric pressure was determined by comparing the measured resistance ratio⁷ with that calculated from Eq. (2) using experimental thermal-expansion data^{8,9} and $\gamma=3.00$.¹⁰ Calculated and measured values agree to better than 0.5% from room temperature to the melting point. Another check on Eq. (1) is possible using compressibility measurements at room temperature^{11,12} and calculating $R(P, T_0)/R(0, T_0)$. These values agree with Bridgman's high-pressure resistance measurements³ to better than 1.5% up to 50 kbar. For high pressure and temperature effects it is convenient to write

$$r_p(T, T_0)/r_0(T, T_0) \\ = [V(P, T)V(0, T_0)/V(0, T)V(P, T_0)]^{2\gamma-4/3}. \quad (3)$$

All quantities on the right-hand side are known except $V(P, T)$. Even without an exact knowledge of the equation of state, it is obvious that (3) predicts a very small negative effect of pressure on $r_p(T, T_0)$. This is

* Supported by the U. S. Air Force Office of Scientific Research.

† Temporary address until September, 1965: University of California, Los Alamos Scientific Laboratory, Los Alamos, New Mexico.

¹ R. P. Huebener and C. G. Homan, *Phys. Rev.* **129**, 1162 (1963).

² R. D. Shelley, Master's thesis, Brigham Young University, Provo, Utah, 1964 (unpublished).

³ P. W. Bridgman, *Proc. Am. Acad. Arts Sci.* **81**, 169 (1952).

⁴ A. H. Wilson, *The Theory of Metals* (Cambridge University Press, Cambridge, England, 1936).

⁵ A. W. Lawson, *Progress in Metal Physics*, edited by B. Chalmers and R. King (Pergamon Press, New York, 1956), Vol. 6, p. 1.

⁶ M. H. Lennsen and A. Michels, *Physica* **2**, 1091 (1935).

⁷ Measurements made by N. R. Mitra in our laboratory at atmospheric pressure with $T_0=30^\circ\text{C}$.

⁸ F. C. Nix and D. MacNair, *Phys. Rev.* **60**, 597 (1941).

⁹ B. N. Dutta and B. Doyal, *Phys. Stat. Solidi* **3**, 473 (1963).

¹⁰ J. G. Collins, *Phil. Mag.* **8**, 323 (1963).

¹¹ P. W. Bridgman, *The Physics of High Pressures* (G. Bell and Sons, London, 1949), p. 161.

¹² W. B. Daniels and C. S. Smith, *Phys. Rev.* **111**, 713 (1958).

most easily recognized by noting that the right-hand side of (3) is the ratio of the thermal expansion at pressure P to that at atmospheric pressure, thus a quantity slightly less than unity. It is possible to estimate the initial decrease of $r_p(T, T_0)$ with pressure by differentiating Eq. (3) with respect to P and evaluating at $P=0$:

$$dr_p(T, T_0)/dP|_{P=0} = r_0(T, T_0)[2\gamma - \frac{4}{3}][K_{T_0} - K_T], \quad (4)$$

where K_T is the isothermal compressibility at temperature T .

2. Melting

The present theories of melting are only first-order approximations¹³ which yield a form known as Simon's equation¹⁴ for normal materials, i.e., those with a melting curve monotonically increasing with pressure. Simon's equation,

$$P_m/A + 1 = (T_m/T_{m,0})^c, \quad (5)$$

is an empirical relation containing two parameters, A and c . T_m is the melting temperature at pressure P_m and $T_{m,0}$ is the melting temperature at atmospheric pressure. Gilvarry¹³ has derived an expression for c using some simple assumptions about melting and his results are carried somewhat further by Babb.¹⁵ In the latter's article, c is given by the formula

$$c = (f + \mu)/(f - 1). \quad (6)$$

If f is assumed to be constant along the melting curve Babb shows that $f = 2\gamma_{m,0} + \frac{1}{3}$. The quantity μ is to be obtained from the volume dependence of the Grüneisen constant using a relation proposed by Gilvarry:

$$(\gamma - \frac{1}{3})/(\gamma_0 - \frac{1}{3}) = (V/V_0)^\mu. \quad (7)$$

In order to determine μ and $\gamma_{m,0}$ one must know how γ varies with volume. Using the Dugdale-MacDonald formula¹⁶ and shock compression data¹⁷ the value of μ is estimated to be 7.99 for gold. Assuming that γ is a function of volume only and employing the expansion of gold to the melting point¹⁸ one obtains $\gamma_{m,0} = 4.43$. These values substituted into Eq. (6) predict $c = 2.10$.

The parameter A can be written in terms of c by using the Clapeyron equation. Differentiating Eq. (5) with respect to T_m and evaluating the result at $T_m = T_{m,0}$ it follows that

$$dP_m/dT_m|_{T_{m,0}} = P_0' = Ac/T_{m,0} = (L/T_{m,0}\Delta V), \quad (8)$$

where L is the latent heat and ΔV is the volume change

at fusion. Therefore $A = L/c\Delta V$ and Simon's equation becomes

$$P_m = (L/c\Delta V)[(T_m/T_{m,0})^c - 1]. \quad (9)$$

Experimental results for $T_{m,0}$, L ,¹⁹ and ΔV ,^{20,21} at atmospheric pressure, are used in Eq. (9) thus leaving only one arbitrary parameter c to be empirically determined.

II. METHOD OF MEASUREMENT

The measurements were accomplished using a 600-ton tetrahedral anvil press²² with a sample container of pyrophyllite in the form of a regular tetrahedron $1\frac{1}{4}$ in. on an edge. The gold was supplied by Nesor Alloy Products Company in the form of 99.999% pure wire 3 mils in diameter. The sample was constructed as shown in Fig. 1. The distance between the potential contacts was about 1 mm and the leads to these contacts were brought out of the pressure cell through 13-mil stainless-steel tubing. Pyrophyllite sleeves were put around the steel tubing and the thermocouple wire to keep them from breaking while the gaskets were forming. The BN served to insulate the gold and the thermocouple from the heater and also to spread the heat to make the temperature more uniform.

Measurements were made at a fixed ram loading while increasing the current through the heater strip and simultaneously recording the thermocouple emf and the resistance between the potential leads. A Kepco 100 A, 8 V, dc regulated power supply served as a source of heater power. The resistance between the potential leads was measured with a four-lead Keithley milliohm meter, the output of which was fed to one axis of a Moseley X-Y recorder. The other axis of the recorder monitored the thermal emf from the thermocouple junction. At the melting point the resistance of

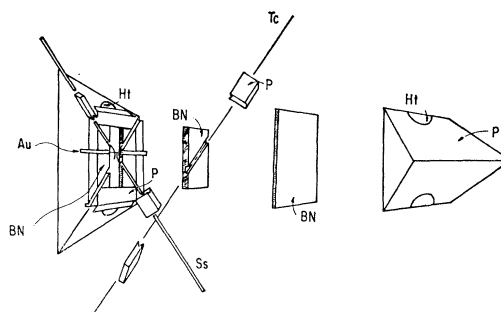

FIG. 1. High-pressure high-temperature sample chamber for resistance measurements in the tetrahedral anvil press. The lettered parts are: P, pyrophyllite; BN, boron nitride; Tc, thermocouple; Ss, stainless-steel tubes; Ht, heater tabs; Au, gold current leads.

¹³ J. J. Gilvarry, Phys. Rev. **102**, 308 and 325 (1956).

¹⁴ F. Simon and G. Glatzel, Z. Anorg. Allgem. Chem. **178**, 309 (1929).

¹⁵ S. E. Babb, Jr., J. Chem. Phys. **38**, 2743 (1963).

¹⁶ J. S. Dugdale and D. K. C. MacDonald, Phys. Rev. **89**, 832 (1953).

¹⁷ J. M. Walsh, M. H. Rice, R. G. McQueen, and F. L. Yarger, Phys. Rev. **108**, 196 (1957).

¹⁸ O. H. Krikorian, University of California, Lawrence Radiation Laboratory Report UCRL-6132, 1960 (unpublished).

¹⁹ Landolt-Börnstein Tables, edited by K. Schäfer and E. Lax (Springer-Verlag, Berlin, 1961), Vol. II, part 4, p. 243.

²⁰ L. Losana, Gazz. Chim. Ital. **68**, 836 (1938).

²¹ W. Krause and F. Sauerwald, Z. Anorg. Allgem. Chem. **181**, 347 (1929).

²² The press was similar to that described by J. D. Barnett and H. T. Hall, Rev. Sci. Instr. **37**, 175 (1964).

the wire suddenly increased by a factor of about 2.2. Thus the melting temperature was sharply defined at each pressure.

Because the wire was tightly confined at these pressures it was possible to melt the wire successively many times, changing the pressure after each melting. The ram loading was calibrated to indicate pressure by measuring the resistance transitions in Bi (25.4 kbar), Tl (37 kbar), and Ba (58 kbar), and interpolating between these values with a smooth curve.

III. MELTING CURVE

The temperature of melting was taken as the temperature at the beginning of the sudden resistance rise as indicated in Fig. 2. Because of the sharpness of the break in the resistance curve one can determine this point to better than $\pm 2^\circ\text{C}$. The accuracy of any temperature measurement however is probably only about $\pm 10^\circ\text{C}$, even though the thermocouple calibration at atmospheric pressure was accurate to $\pm 5^\circ\text{C}$ at these temperatures, because no pressure correction to the thermal emf was attempted.²³

Each run consisted of a set of melting points at various pressures. The results of the four successful melting runs did not all lie on the same curve. This could be due to variation in the thermocouple calibration or to thermal gradients along with the difficulty of placing the thermocouple junction at a point corresponding to the hottest region along the gold wire. Temperature gradients, large enough to account for the differences, are evident from the width of the transition which was between 20 and 30°C. In order to correct for this uncertainty the temperatures of each run were all raised or lowered by an amount such that the melting curves extrapolated to the correct melting point at atmospheric pressure with the slope calculated from Clapeyron's equation.²⁴ The corrections amounted to -13 , -11 , $+5$, and $+11^\circ\text{C}$ for the four runs. After this correction all points from all runs lay on a single smooth curve with a maximum scatter less than $\pm 7^\circ\text{C}$.

Another correction should be applied to the raw data because the pressure calibration was at room temperature rather than at the temperature of the experiment. The pressure cell expands with increasing temperature causing the pressure to rise. This does not appear as an increase on the oil pressure behind the rams because of internal friction in the pyrophyllite and friction in the pistons themselves. Above 40 kbar the gaskets are essentially immovable and it was assumed that the pressure increase due to heating was proportional to the temperature change from room tempera-

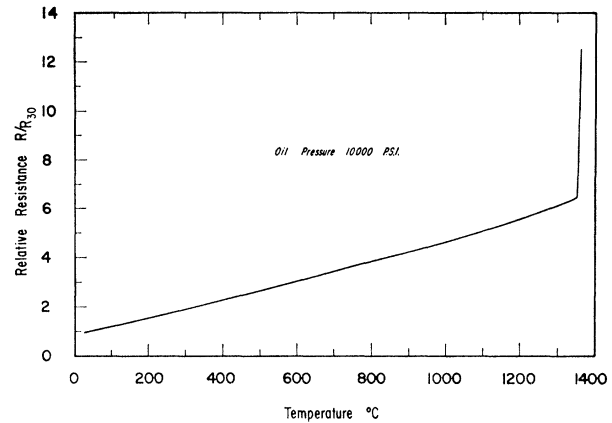

FIG. 2. Relative resistance of gold as a function of temperature at 10 000-psi oil pressure. (10 000-psi oil pressure corresponds to 52.2 kbar for the sample at room temperature.)

ture to the melting point. Below 15 kbar the gaskets are still forming and as the volume expands more material is forced into these gaskets between the anvils giving no pressure increase in this range. Between 15 and 40 kbar the correction was assumed to vary smoothly from 0 to the value at 40 kbar. Evidences for the above assumptions are: (a) Upon cooling the sample after melting at a pressure less than 15 kbar one notes a drop in the oil pressure. This indicates that the volume after the heating cycle is less than before allowing the rams to move in and the oil pressure to drop. (b) The raw melting curve between 15 and 40 kbar shows a slight upward curvature which is removed by applying the proposed pressure correction. The amount of the pressure correction above 40 kbar is not known so it was determined from the melting curve itself by assuming that this curve should have the form of Simon's equation.

The method of obtaining the pressure correction along with the coefficient c in Eq. (9) is outlined below. Substitution of $T_m = T_{m,0} + \delta T$ into Eq. (9) and expanding in a power series in $\delta T/T_{m,0}$ yields the following equation after some manipulation:

$$P_m - P_0' \delta T = \frac{(c-1)P_0'}{2} \frac{(\delta T)^2}{T_{m,0}} \left[1 + \frac{c-2}{3} \frac{\delta T}{T_{m,0}} \dots \right]. \quad (10)$$

If one plots experimentally measured values of $(P_m - P_0' \delta T)$ versus $(\delta T)^2$ as in Fig. 3 the points indicated by the open circles are obtained. The desired pressure correction is applied to the measurements above 40 kbar so as to cause them to fall along a curve satisfying (10) with a least-mean-square deviation. The final results are represented by the closed circles with $c = 2.2 \pm 0.1$ and a maximum pressure correction of 3.9 kbar at 66.7 kbar. The corrected results are finally graphed in Fig. 4.

²³ F. P. Bundy, J. Appl. Phys. 32, 483 (1961).

²⁴ It is to be noted that one set of measurements, shown by the point numbers 2, 3, 4, 5, 7, 8, and 10 in Fig. 4, extend down to 3.5 kbar and have an initial slope of $5.9 \pm 0.2^\circ\text{C}/\text{kbar}$ in excellent agreement with the value $5.91^\circ\text{C}/\text{kbar}$ calculated from Clapeyron's equation.

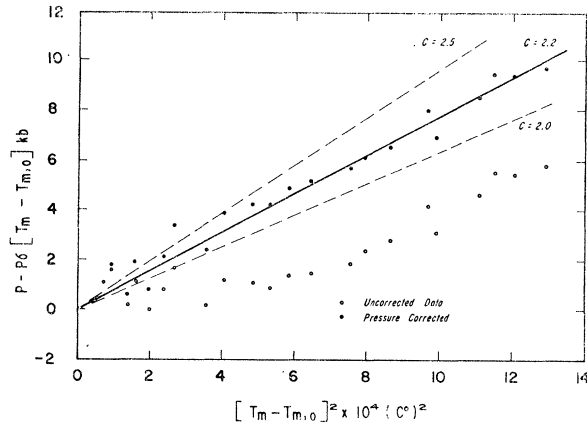

FIG. 3. Normalized melting pressure as a function of the square of the increase in melting temperature. This curve is used in the determination of the Simon equation parameter.

IV. RESISTANCE MEASUREMENT

The high-temperature measurements were made by heating the sample to the melting point at several fixed pressures. As discussed in the previous section the pressure increases as the temperature is raised. By using the pressure increase determined at the melting point and assuming a linear increase with temperature at intermediate points a small pressure correction was applied to the raw data. The results from 9 different samples are shown in Fig. 5 where the reference temperature T_0 was taken at 30°C. One can never be sure that the application of pressure will not alter the dimensions of the specimen; thus all results are given relative to the resistance at room temperature at each pressure. The initial decrease in $r_p(T, T_0)$ was calculated using Eq. (4) in which the compressibilities were estimated using Grüneisen's relation, $K_T = \alpha V / \gamma C_v$, with experimental values of thermal expansion.²⁵ The calculated decrease is shown as a solid line in Fig. 5. The data

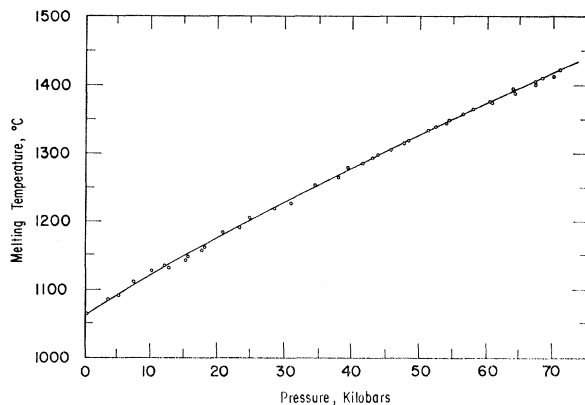

FIG. 4. Pressure dependence of the melting temperature of gold.

²⁵ See Refs. 8 and 9.

at higher temperatures appear to fall below this calculated curve. It is possible that the difference is due to the decrease in the equilibrium number of vacancies at high pressures.²⁶ The vacancy contribution to the resistance can be estimated from the measurements of Meechan and Eggleston.²⁷ The dashed curve in Fig. 5 is the calculated resistance ratio including the effect of vacancies.

The initial heating cycle generally gave a slightly larger value for $r_p(T, T_0)$ than successive cycles even at the same pressure. This may cause the results to be too low at higher pressures. To check this possibility, four runs were made at about 53 kbar, each sample being melted only once, and the resistance measured only on

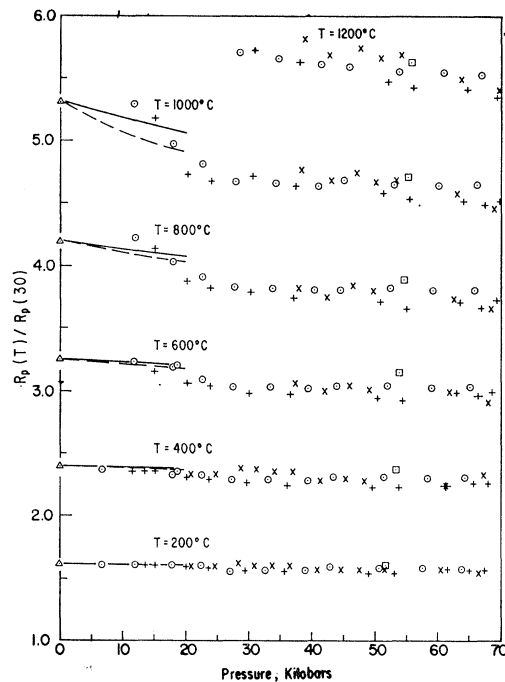

FIG. 5. Resistance of gold at temperature T to that at 30°C as a function of pressure. The solid line follows the calculated initial slope at zero pressure and the dashed line is the calculated curve after a vacancy correction is made.

the initial temperature increase. The average of these results, as shown by the squares in Fig. 5, was slightly higher than the other measurements but not significantly so. As the temperature increased the surrounding BN became conducting, the insulation resistance dropping to about 10 Ω at the melting point. This was due to a black substance that would form over the surface of the BN above 600°C. This material proved to be conducting and tended to short out the gold at high

²⁶ H. H. Grimes, National Aeronautics and Space Administration Technical Note, NASA TN D-2371, UR-64-201366 (National Aeronautics and Space Administration, Washington, D. C., July 1964).

²⁷ C. J. Meechan and R. R. Eggleston, *Acta Met.* 2, 680 (1954).

temperatures, possibly giving too low a value for $r_p(T, T_0)$.

The measurements at atmospheric pressure shown by the triangles in Fig. 5 were made in a muffle furnace in an air atmosphere. These data are about 3% larger than those reported by Meechan and Eggleston.²⁷

An independent measurement of $R(P, T)$ in a liquid system was made for temperatures up to 650°C and pressures to just above 50 kbar. The sample consisted of a 3.0-cm length of 3-mil gold wire with 1-mil potential leads 2.3 cm apart, immersed in petroleum ether. The gold wire and petroleum ether were contained in a $\frac{3}{16}$ -in.-diam thin-walled monel heater tube 0.45 in. long with a Teflon plug in each end. Values of $R_p(T)/R_p(30)$ agreed well with the data of Fig. 5 for all temperatures. The measurement of $R(P)$ at room temperature, however, has a negative curvature in contrast to Bridgman's data which has positive curvature over the same pressure range.³ It is believed that this data as tabulated in Table I is quite reliable, inasmuch as the sample showed no apparent deformation upon microscopic examination after removal from the press. Values calculated from Eq. (1) along with Bridgman's data are also shown in Table I for comparison.

TABLE I. Variation of resistance of gold with pressure at room temperature.

Pressure kbar	Present measurement	$R(P)/R(0)$	
		Bridgman ^a	Calculated from compressibility
0	1.000	1.000	1.000
10	0.981	0.970	0.972
20	0.950	0.945	0.944
30	0.918	0.920	0.916
40	0.886	0.895	0.889
50	0.853	0.875	0.862

^a See Ref. 3.

The resistance at any point can be determined relative to that at atmospheric pressure and 30°C by determining the ratio

$$\frac{R(P, T)}{R(0, T_0)} = \left[\frac{R(P, T)}{R(P, T_0)} \right] \left[\frac{R(P, T_0)}{R(0, T_0)} \right]. \quad (11)$$

The first factor on the right is given by the data in Fig. 5 and the second factor is obtained from Table I. From the experimental results we find that the ratio $R(P, T_m)/R(0, T_0)$ at the melting point is constant to within about $\pm 2\%$ at all pressures. Thus to within the accuracy of these measurements the resistance at the melting point is a constant independent of pressure.

V. CONCLUSIONS

This method of measuring melting temperatures at high pressures is more sensitive than other methods

previously tried. The melting temperature can be measured both on increasing and decreasing temperature with good reproducibility and the transition region is generally narrower than with other techniques. The results are also independent of the rate at which the temperature is changed. The melting curve of gold, reported here, is felt to be quite accurate even though the raw data had to be corrected. The correction amounted to less than 14°C in temperature and less than 9% in pressure for any point. These corrections make very little change in the position of the melting curve but they do affect the coefficient c in Simon's equation. It is possible to fit the uncorrected data reasonably well to the form of Simon's equation but the resulting expression has an unreasonably large initial slope and does not pass through the correct melting temperature at zero pressure. The coefficient c for the uncorrected data was about twice as large as that calculated from the data after correction. Our experimental value of $c = 2.2 \pm 0.1$ agrees very well with the value 2.1 estimated theoretically. No corrections were attempted to account for pressure effects on the thermocouple emf but it is felt that the method of analysis and the other corrections will partially compensate for any errors introduced here. To our knowledge no other melting curves measured to high pressures have been corrected for thermal-expansion effects. This correction would alter the Simon's coefficients calculated from these measurements and probably improve the agreement with theory.

This is one of the first attempts to make accurate resistance measurements at high pressures and temperatures. Measurements on the resistance of iron have been published by Clougherty and Kaufman,²⁸ but there is considerable scatter in their results and the ratio $R(R, T)/R(P, T_0)$ is very erratic. One of the greatest difficulties proved to be that of finding a good insulating material, that conducts heat rather well, whose electrical resistance is not adversely affected by the high temperatures. The results show relatively little scatter and follow the expected slight decrease of temperature coefficient of resistance with increasing pressure. However, our results show a more rapid initial decrease in this coefficient than one would expect from Eq. (4) but agree reasonably well with the analysis of Eq. (4) if one considers the rapid decrease in the equilibrium concentration of vacancies at high pressures.

From the result that the resistance at the melting point is constant one can show a very simple relation between the volume and temperature at the melting point. Inserting $T = T_m$ into Eq. (1) one arrives at the conclusion that $T_m V_m^{2\gamma-4/3} = \text{constant}$. It would be interesting to check out this relation using high-pressure x-ray techniques.

²⁸ E. V. Clougherty and L. Kaufman, in *The Physics and Chemistry of High Pressures* (The Society of Chemical Industry, London, 1963).