

Method of Reducing the Uncertainty in Neutrino Mass*

ROBERT R. LEWIS, JR.

Department of Physics, The University of Michigan, Ann Arbor, Michigan

(Received 14 May 1964)

Both the neutrino mass and the Fermi level of a degenerate neutrino gas are limited by experiments on the decay spectra near the maximum recoil momentum (or maximum electron energy). The possibility of studying this portion of the spectrum by resonance fluorescence of a subsequent gamma ray, is examined. Discussion of the resolution available with this technique indicates that an improvement in the limits on neutrino mass and Fermi level may be possible.

INTRODUCTION

IT has long been recognized that the upper limit of the electron spectrum in beta decay provides important information regarding the neutrino.¹ Since electrons with the maximum energy are emitted together with neutrinos of the minimum energy, this portion of the spectrum is strongly dependent on the neutrino mass. High-resolution measurements of the tritium spectrum provide the best existing limit to the neutrino mass² ($m_\nu \leq 200$ eV). More recently, it has been pointed out that these same measurements limit another important property of the neutrino—the Fermi level of a universal degenerate neutrino gas³ ($E_F \leq 200$ eV). The problem of improving the limits on these two parameters⁴ provides the motivation for this work; it is basically a problem in improving the instrumental resolution.

The same information present in the upper limit of the electron spectrum is, in principle, present in the line shape of the subsequent gamma spectrum, because the recoil momentum spectrum determines the line shape. Since the measurement of the shape of the gamma spectrum with high resolution is a completely different physical problem, we wish to focus attention on such means of improving the limits on m_ν and E_F . In particular, we will consider resonance fluorescence experiments in which the recoil momentum imparted by the beta decay provides the Doppler shift necessary to establish fluorescence.⁵ Such experiments have already been successfully performed and have provided a means of

determining the neutrino helicity⁶ and the electron-neutrino correlation function.⁷

A moment's consideration shows that existing fluorescence experiments are insensitive to m_ν and E_F , since relatively energetic neutrinos are involved. In designing an experiment to measure these parameters the neutrinos must be of very low energy, and so the electrons must carry off the full energy release. This gives a definite recoil momentum $p_0 = (W^2 - m^2)^{1/2}$ to the nucleus. The condition that this recoil be correct to produce fluorescence of the subsequent gamma is then simply $p_0 = E$. For such nuclei, resonance fluorescence will occur for those gamma rays emitted antiparallel to (and in coincidence with) electrons of maximum energy. It may be useful, but is not necessary, to demand coincidence of the two radiations. The experiment consists of observing the intensity of the fluorescent scattering versus the relative velocity of source and absorber, thus moving the absorption line over the high-energy end of the gamma spectrum. The shape of this end of the spectrum is sensitive to m_ν and E_F and is calculated in the following sections.

CALCULATION OF GAMMA SPECTRUM

In this section we will present the results of a calculation of the line shape of the gamma spectrum for a β - γ cascade. It is assumed throughout that the motion of the center of mass of the nucleus is that of a free particle of given mass.

A. Kinematics

Denote the levels of the nucleus by N, N_1, N_2 with masses M, M_1, M_2 and spins J, J_1, J_2 etc. Furthermore, introduce the conventional notation

$$M_1 = M + E,$$

$$M_2 = M_1 + W_0, \quad \text{setting } \hbar = 1, c = 1$$

everywhere. Then, application of energy-momentum conservation implies that the absorption line of the state N at rest is at $\omega_0 = E + E^2/2M$, whereas the emission line of the state N_1 at rest is at $\omega_1 = E - E^2/2M_1$. The emis-

* Supported in part by U. S. Office of Naval Research, Department of the Navy.

¹ J. Allen, *The Neutrino* (Princeton University Press, Princeton, New Jersey, 1958), Chap. 2.

² J. J. Sakurai, *Phys. Rev. Letters* **1**, 40 (1958).

³ S. Weinberg, *Phys. Rev.* **128**, 1457 (1962).

⁴ There are not necessarily only two parameters. It has been established that there are four different neutrino states $\nu_e, \bar{\nu}_e, \nu_\mu, \bar{\nu}_\mu$ with possibly different masses and Fermi levels. We are concerned here only with ν_e and $\bar{\nu}_e$ and will assume throughout that they have the same mass. Further we will assume either degenerate ν_e or degenerate $\bar{\nu}_e$, but not a mixture of the two. This is done in the interest of simplicity. The only simple theory which is ruled out of consideration is the CP-invariant neutrino degeneracy with both ν_e and $\bar{\nu}_e$ states symmetrically filled (and half-degenerate; see Ref. 3).

⁶ For a recent review of this subject, see F. R. Metzger, *Progr. Nucl. Phys.* **7**, 54 (1959).

⁶ M. Goldhaber, L. Grodzins, and A. W. Sunyar, *Phys. Rev.* **109**, 1015 (1958).

⁷ N. E. Booth, G. W. Hutchinson, A. M. Segar, G. G. Shute, and D. H. White, *Nucl. Phys.* **11**, 341 (1959).

sion line for gamma rays emitted in direction \hat{k} from state N_1 with momentum \mathbf{P} is at

$$\omega = \frac{\omega_1}{\gamma(1 - \mathbf{P} \cdot \hat{k} / \gamma M_1)},$$

where $\gamma = [1 - \beta^2]^{-1/2}$ is the time dilatation factor for the moving source. If we expand these results keeping only first-order terms in both E/M and β we obtain

$$\begin{aligned} \omega_0 &= E(1 + E/2M), \\ \omega_1 &\cong E(1 - E/2M), \\ \omega &\cong \omega_1(1 + \mathbf{P} \cdot \hat{k} / M). \end{aligned}$$

It will be convenient to introduce the quantity z (the component of \mathbf{P} parallel to \hat{k})

$$z = M[(\omega - \omega_1)/E] \cong \mathbf{P} \cdot \hat{k}$$

as the variable denoting the gamma energy; the spectrum emitted by a source at rest will be centered on $z=0$. The absorption line of a target at rest will be centered on $z=E$.

B. Matrix Element

We have previously formulated the calculation of the matrix element for this case.⁸ The square of the matrix element, suitably averaged over unobserved spins, can be written as

$$\langle |M|^2 \rangle_{\text{av}} \sim F(E_p) \left[1 + B \frac{\mathbf{p} \cdot \mathbf{q}}{E_p E_q} + C \frac{\mathbf{p} \cdot \hat{k} \mathbf{q} \cdot \hat{k} - \frac{1}{3} \mathbf{p} \cdot \mathbf{q}}{E_p E_q} \right].$$

Over-all constants have been dropped, but the full energy and angular dependence has been made explicit. This result is sufficiently similar to that of Ref. 7 that

$$N_{1,2}(z) = \int \int d^3p d^3q F(E_p) \left\{ 1 + B \frac{\mathbf{p} \cdot \mathbf{q}}{E_p E_q} + C \frac{\mathbf{p} \cdot \hat{k} \mathbf{q} \cdot \hat{k} - \frac{1}{3} \mathbf{p} \cdot \mathbf{q}}{E_p E_q} \right\} \delta(W_0 - E_p - E_q) \delta(\mathbf{p} \cdot \hat{k} + \mathbf{q} \cdot \hat{k} + z),$$

$$N_3(z) = \int \int d^3p d^3q F(E_p) \{ 1 + \dots \} \delta(W_0 - E_p - E_q) \delta(\mathbf{p} \cdot \hat{k} + \mathbf{q} \cdot \hat{k} + z) \Theta(E_q - E_F),$$

$$N_4(z) = N_1(z) + \int \int d^3p d^3q F(E_p) \{ 1 + \dots \} \delta(W_0 - E_p + E_q) \delta(\mathbf{p} \cdot \hat{k} - \mathbf{q} \cdot \hat{k} + z) \Theta(E_F - E_q),$$

where $\Theta(x) = 1$ for $x > 0$, $= 0$ for $x < 0$. These results are self-evident when one identifies $\mathbf{P} = -\mathbf{p} - \mathbf{q}$ for the decays and $\mathbf{P} = -\mathbf{p} + \mathbf{q}$ for the neutrino reactions. Consistent with our aim of including recoil effects only to first order in E/M , we have neglected the recoil energy $(\mathbf{p} + \mathbf{q})^2/2M$ in the beta transition. The over-all normalization of the spectra is arbitrary, but the relative normalization of N_1, \dots, N_4 is correct.

⁸ R. R. Lewis and R. B. Curtis, Phys. Rev. **110**, 910 (1958).

⁹ As was pointed out in Ref. 2, the γ_5 invariance of the theory rules out the appearance of certain terms in the matrix elements which would otherwise be present. There is therefore considerable simplification in the analysis of experimental results if this invariance is assumed. If the interaction contains only the combination $a\Psi_p$ with $a = \frac{1}{2}(1 + i\gamma_5)$, then the trace will contain a factor $a(\hat{q} + m_e)\bar{a} = a\hat{q}$ and so m_e does not appear explicitly. A similar simplification results in the Coulomb corrections: if the interaction contains a ψ_e , then the trace contains a factor

$$aF(E_p) \{ \gamma_4 E_p - \boldsymbol{\gamma} \cdot \mathbf{p} + \gamma m_e - i(Ze^2 m_e^2 / p) \gamma_4 \boldsymbol{\gamma} \cdot \mathbf{p} \} \bar{a} = aF(E_p) \hat{p}$$

and the Coulomb field alters the matrix element only by a multiplicative factor.

it is only necessary to comment on the differences:

(1) Experience has shown that $C_V \cong C_V'$ and $C_A \cong C_A'$ (γ_5 -invariant $V-A$ theory), and so

$$A = 1, \quad B = \frac{|C_V M_F|^2 - \frac{1}{3} |C_A M_{GT}|^2}{|C_V M_F|^2 + |C_A M_{GT}|^2}, \text{ etc.}$$

(2) Inclusion of a finite neutrino mass into this theory introduces no new terms depending explicitly on m_ν .⁹ The only modification necessary is to properly distinguish between momentum q and energy E_q .

(3) The matrix element for the neutrino reaction

$$\nu + N_2 \rightarrow N_1 + e$$

is also required for calculations with a neutrino degeneracy. It can be obtained from the above by the crossing relation by simply reversing the sign of E_q and \mathbf{q} . This is seen to leave the expression unchanged.

C. Gamma Spectrum

The distribution of decay events, and hence the spectrum of emitted gammas, can be obtained from this matrix element and the appropriate density of states. We will consider separately four possibilities:

- (1) $m_\nu = 0; E_F = 0$,
- (2) $m_\nu \neq 0; E_F = 0$,
- (3) $m_\nu = 0; E_F \neq 0$ for antineutrinos,
- (4) $m_\nu = 0; E_F \neq 0$ for neutrinos.

The spectra, designated by indices 1, \dots , 4, are found by evaluating the number of decays with fixed component of recoil momentum parallel to k :

In each of these integrals the azimuthal average of \mathbf{p} and \mathbf{q} about \hat{k} can be performed, and the variables x, y introduced

$$x = -\mathbf{p} \cdot \hat{k}, \quad y = -\mathbf{q} \cdot \hat{k},$$

with domains $-p \leq x \leq p; -q \leq y \leq q$. The resultant expressions are

$$N_{1,2} = \iint dE_p dE_q F(E_p) \iint dx dy \{E_p E_q + \alpha xy\} \delta(W_0 - E_p - E_q) \delta(x + y - z),$$

$$N_3 = \iint dE_p dE_q F(E_p) \iint dx dy \{E_p E_q + \alpha xy\} \delta(W_0 - E_p - E_q) \delta(x + y - z) \Theta(E_q - E_F),$$

$$N_4 = N_1 + \iint dE_p dE_q F(E_p) \iint dx dy \{E_p E_q + \alpha xy\} \delta(W_0 - E_p + E_q) \delta(x - y - z) \Theta(E_F - E_q),$$

with $\alpha = B + \frac{2}{3}C$. Next perform the integrals over the neutrino variables E_q and y . In the first integrals, set $E_q = W_0 - E_p, \quad q = [(W_0 - E_p)^2 - m_\nu^2]^{1/2}, \quad y = z - x$ and obtain

$$N_{1,2} = \iint_{D_{1,2}} dE_p dx F(E_p) \{E_p E_q + \alpha xy\},$$

$$N_3 = \iint_{D_3} dE_p dx F(E_p) \{E_p E_q + \alpha xy\}.$$

In the last, set $q = E_q = E_p - W_0, \quad y = x - z$ and obtain

$$N_4 - N_1 = \iint_{D_4} dE_p dx F(E_p) \{E_p E_q + \alpha xy\}.$$

The spectra are all symmetrical in z .

At this point it is very helpful to rely on a graphical representation of the domains of these integrals in the E_p, x plane. First draw the hyperbolas $p(E_p)$ and $q(E_p)$; the domain of integration is then, for given z , the interior of the intersection of the hyperbolas $p(E_p)$ and $z + q(E_p)$ [that is, $q(E_p)$ shifted upwards an amount z]. For N_3 and N_4 we must also include the straight lines $q = E_F$ as boundaries. If $m_\nu = 0$ then the hyperbola $q(E_p)$ degenerates into a pair of straight lines. A sample region for N_2 is sketched in Fig. 1.

If for any reason it is appropriate to perform the experiment by demanding coincidence between the resonant gamma ray and the electron, then the spectra can be calculated by modifying the limits of these integrals. In order to reduce background, it may be necessary to eliminate counts from events in which $E_p < \bar{E}_p$ and $X < \bar{X}$.

Many of the qualitative aspects of the spectrum are made clear by a study of these graphs. It is evident that the effects of m_ν and $E_F \neq 0$ are negligibly small for intermediate values of z ; only near the extreme ends of the spectrum does the value of these parameters strongly influence the shape.

D. Threshold Behavior

The exact evaluation of these spectra by analytical means is out of the question; numerical methods will have to be used for any given experiment. But the behavior near the upper limit can be studied in general. First the threshold value z^* must be found. Then, for small values of $\zeta = z^* - z$, the integrand must be expanded about a point in the small domain which contributes, and the integral performed. In Fig. 2 we show graphically an (exaggerated) sketch of these domains. The results for the location of the threshold are

$$z_1^* = (W_0^2 - m_e^2) = p_0,$$

$$z_2^* = [W_0^2 - (m_e + m_\nu)^2]^{1/2} \cong p_0 - m_e m_\nu / p_0,$$

$$z_3^* = [(W_0 - E_F)^2 - m_e^2]^{1/2} + E_F \cong p_0 - E_F [m_e^2 / p_0 (W_0 + p_0)],$$

$$z_4^* = [(W_0 + E_F)^2 - m_e^2]^{1/2} + E_F \cong p_0 + E_F [(W_0 + p_0) / p_0].$$

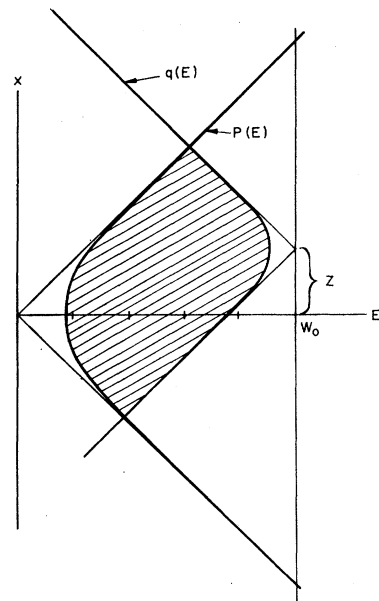

FIG. 1. Domain of integration in E_p, x plane for typical point in gamma spectrum.

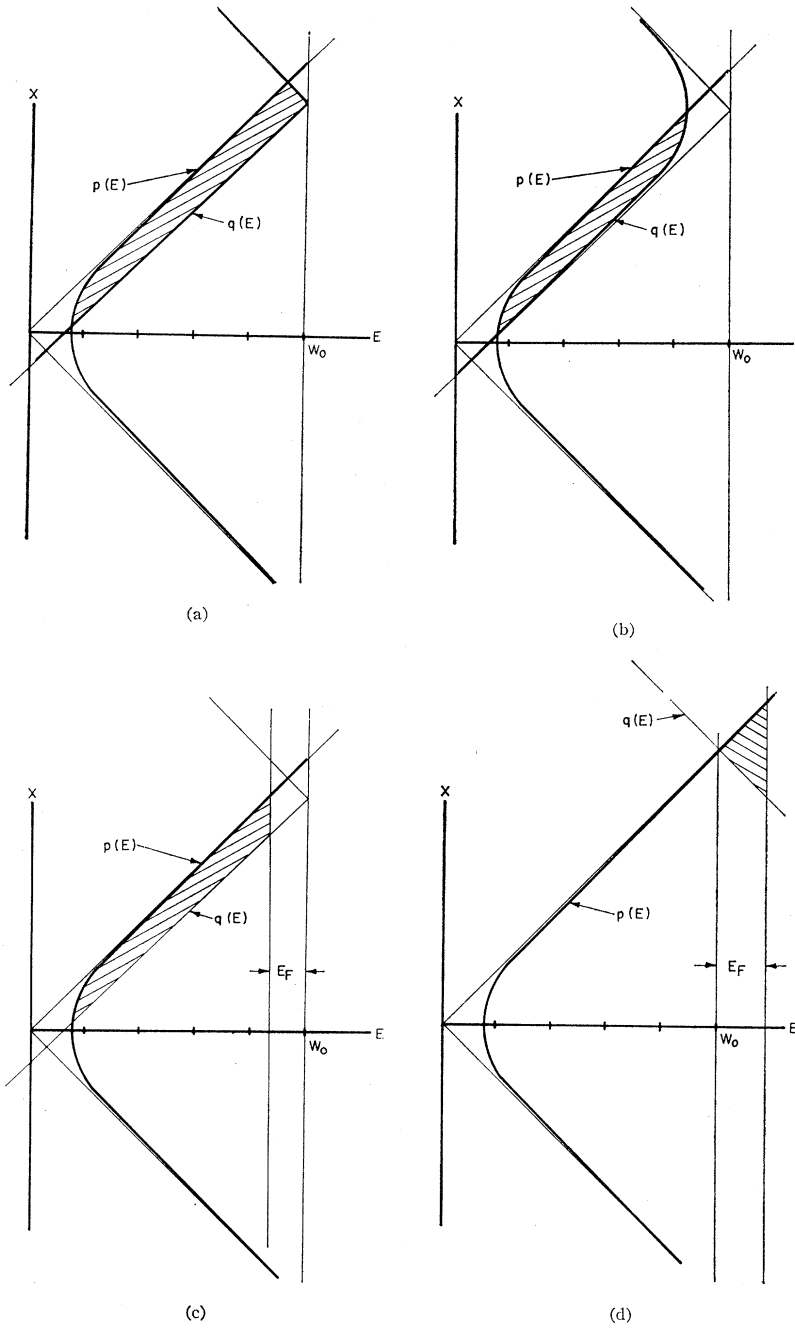

FIG. 2. Domains of integration for gamma spectra near threshold. The spectra N_1, N_2, N_3, N_4 are described in (a), (b), (c), and (d).

The results for the threshold behavior are¹⁰

$$\begin{aligned}
 N_1(\xi) &\cong \frac{2}{3} (p_0^3/m_e^4) (W_0^2 + \alpha p_0^2) \xi^3, \\
 N_2(\xi) &\cong \frac{2}{3} [(W_0^2 + \alpha p_0^2)/m_e^4] [2m_e m_\nu p_0 \xi]^{3/2}, \\
 N_3(\xi) &\cong \frac{1}{2} [p_0(W_0 + p_0)(W_0 + \alpha p_0)/m_e^2] E_F \xi^2, \\
 N_4(\xi) &\cong \frac{1}{2} [p_0(W_0 - \alpha p_0)/W_0 + p_0] E_F \xi^2.
 \end{aligned}$$

¹⁰ Only the leading term near threshold is included; the slight variation of $F(E_p^*)$ is ignored and a common factor $F(W_0)$ dropped; only the leading terms for small m_ν and E_F are retained.

These results show the sensitivity of the spectrum on the parameters m_ν and E_F . We see that there are quite characteristic shapes in the four models—if only the resolution is sufficient to see them.

DISCUSSION

The first requirement of a successful application of these calculations is a source satisfying the condition $p_0 \simeq E$, together with the many other requisites for a fluorescence experiment. This work was originally

motivated by the observation that the famous O^{14} decay satisfied these conditions: the discrepancy between momenta of the N^{14} gamma ray and the positron of maximum energy is only 44 keV/c out of 2311 keV/c, or about 2%. Moreover, the requirements of abundance of N^{14} , lifetime of N^{14*} , . . . are all adequately met. The N^{14} gamma ray has in fact already been seen to fluoresce. The discrepancy in momenta causes a shift of the absorption line away from the end of the spectrum, which must be compensated by a relative motion of source and detector: in this case the necessary velocity is 1×10^5 cm/sec to restore the resonance, and an additional velocity to move the resonance over the end point.

Such a close agreement between p_0 and E is more frequent than one might perhaps expect. A search of the nuclear data tables reveals further examples, the most favorable of which are selected for Table I, in which some of the relevant data are presented. The columns give, respectively, the transition, the abundance of the daughter nucleus, the momenta of the gamma ray and electron (in keV/c), the relative velocity (in cm/sec) necessary to establish fluorescence at the end point, and the mean life of the gamma emitting state (in sec). A positive value of the relative velocity refers to motion towards one another.

It was stressed in the introduction that the measurement of gamma ray energies with high resolution was a *different* physical problem from measurement of electron energies. But is it *easier* or *harder*? Of course the absolute resolution available with a fluorescence measurement is much better than for measurement of electron energies. But the relevant energies in the gamma-ray spectrum are also smaller, being reduced by roughly a factor (m_e/M). The full width of the gamma-ray line is $\omega = 2(p_0/M)E$, and the shift of the threshold for m_e and $E_F \neq 0$ is

$$\Delta\omega_2 = (m_e m_\nu / M p_0) E, \quad \Delta\omega_3 = [m_e^2 E_F / M p_0 (w_0 + p_0)] E, \\ \Delta\omega_4 = [(w_0 + p_0) E_F / M p_0] E.$$

One is faced with the problem of resolving these small shifts by reduction of the many sources of broadening. The feasibility of accomplishing this will be explored by several comments.

(1) Consider first a "typical" source, with $p_0 = E \simeq 1$ MeV, $A \simeq 100$; the recoil energy is $E^2/2M \simeq 5$ eV and so the full linewidth is $\omega \simeq 20$ eV and the required resolution is (with $m_\nu \simeq E_F \simeq 200$ eV) $\Delta\omega_2 \simeq 1 \times 10^{-3}$ eV, $\Delta\omega_3 \simeq 2 \times 10^{-4}$ eV, $\Delta\omega_4 \simeq 4 \times 10^{-3}$ eV. This resolution is comparable to a "typical" natural linewidth. But having assumed in the analysis a free *recoil* of the source, it seems we should assume a free thermal motion of source and detector, and hence a Doppler broadening, rather than natural broadening, of the lines. At room temperature, this implies $\Delta\omega_{\text{thermal}} = 2E(2kT \ln 2/M)^{1/2} \simeq 1$ eV, for our typical source. This indicates the complete

TABLE I. Data on sources (taken from Nuclear Data Sheets).

Source	Abundance (%)	E	p_0	$(p_0 - E)/M$	τ
$O^{14} \rightarrow N^{14a}$	99	2311	2267	$+1 \times 10^6$	7×10^{-14}
$Ga^{64} \rightarrow Zn^{64}$	49	3250	3280	-2×10^4	?
$Rb^{86} \rightarrow Sr^{86}$	10	1084	1093	-3×10^4	?
$I^{131} \rightarrow Xe^{131}$	21	638	666	-7×10^8	?
$Lu^{177} \rightarrow Hf^{177}$	18	321	459	-2×10^4	?

^a The 2311 gamma ray has been studied in fluorescence by C. P. Swann, V. K. Rasmussen, and F. R. Metzger, Phys. Rev. 121, 242 (1961).

impracticality of attempting to improve on the limits in this way.

(2) The thermal broadening can be eliminated by a number of possible tricks. Consider the case of the oxygen activity. It seems feasible to consider construction of a continuous source of O^{14} in which the atoms are ionized and accelerated slightly to form a well-collimated beam. The velocity and angular position of the detector can then be varied to sweep the absorption line over the desired portion of the spectrum, utilizing the first-order Doppler shift in frequencies. Assuming a negligible spread in velocity components transverse to the beam, the resolution is determined by the spread in longitudinal velocities and by the angular resolution. If the angle between beam direction and detector is θ , then $\Delta\omega/\omega = (v/c) \sin\theta \Delta\theta + \cos\theta (\Delta V/c)$. For angles near $\frac{1}{2}\pi$ the limiting factor is angular resolution, and near 0 is velocity resolution. It appears feasible to attain the desired resolution; energies of only a few volts suffice to establish resonance at angles $> \frac{1}{4}\pi$ where the angular resolution dominates. The necessary resolution is at least

$$\Delta\omega_4/\omega \simeq (W_0 + P_0) E_F / P_0 M \simeq 3 \times 10^{-8},$$

which implies an angular resolution

$$\Delta\theta \lesssim 3 \text{ mrad.}$$

It is difficult to say whether an experiment can be successfully performed with such narrow slits, in view of the severe limitations of intensity. The resolution seems accessible however.

(3) For the other sources, with a *reduction* of the gamma-ray energy required for fluorescence at the end point, one can consider utilizing the second order transverse Doppler shift ($\theta = \frac{1}{2}\pi$). This reduces the effect of a spread in velocities in the beam still further, but does not alter the required angular resolution, which is still dominated by first-order Doppler effect. For the activities in Table I, the required energies are from 60 to 120 keV.

(4) The most attractive possibility of all is the elimination of recoil effects by binding in crystals (recoilless radiation), with resolution comparable to the natural width. This subject is currently under investigation by the author.