

Isotopic Effects in the X-Ray Spectrum of Muonic Atoms of Ca^{40} and $\text{Ca}^{44}\dagger$

J. A. BJORKLAND, S. RABOY, AND C. C. TRAIL*
Argonne National Laboratory, Argonne, Illinois

AND

R. D. EHRLICH AND R. J. POWERS‡
University of Chicago, Chicago, Illinois

(Received 5 June 1964)

The $2p \rightarrow 1s$ transitions in muonic atoms of Ca^{44} and Ca^{40} were compared by use of a NaI(Tl) scintillation spectrometer with an anticoincidence annulus of NaI(Tl). It was found that the energy of the $2p \rightarrow 1s$ transition in Ca^{40} is 0.9 ± 0.3 keV greater than that in Ca^{44} .

I. INTRODUCTION

SOME of us participated in an earlier measurement¹ of the isotope shift of the $2p \rightarrow 1s$ transition in muonic atoms of Ca^{44} and natural Ca. This early result seemed to be based on a sound statistical analysis of the data although, as was noted in Ref. 1, the gain of the detecting apparatus shifted during the course of the experiment by an amount equivalent to about 60 keV at the energy of the mesic K_{α} transition in Ca. Nevertheless, the result reported for the isotopic shift was considered reliable and aroused interest among theoretical nuclear physicists.

The development and installation of the muon channel^{2,3} at the FM cyclotron of the University of Chicago produced a 20-fold increase in the intensity of the muons. It was therefore decided to repeat this measurement and take advantage of the increased muon intensity to enhance the quality of the data with no sacrifice in counting rate relative to that of Ref. 1.

Many precautions to maintain the stability of the electronics were taken. The more obvious precautions included lowering the values of the resistors between dynodes of the photomultiplier and using new power supplies to provide the larger currents with acceptable stability. An external voltage-stabilization circuit was used to compensate for any slow drifts. The multi-channel analyzer was gated to accept counts only during that part of the cyclotron pulse corresponding to high counting rates. During the time of accumulation of data (more than 1 week) the positions of the full-energy peaks of the muonic x rays of interest showed a maximum variation of only about 2 keV.

We now report the energy of the $2p \rightarrow 1s$ transition in the muonic atom of Ca^{40} is 0.9 ± 0.3 keV more energetic than that of Ca^{44} .

II. APPARATUS AND ELECTRONICS

Figure 1 is a layout of the experiment. The particle beam emerging from the University of Chicago muon channel was composed of muons, pions, and electrons in the proportions of about 2:2:1. The beam underwent momentum selection at approximately 150 MeV/c by a wedge magnet and was collimated to a $7\frac{1}{2} \times 7\frac{1}{2}$ -in. area by a Pb wall 2 ft thick. This beam delivers about 10 000 muons/sec in this area. About 5000 muons/sec stopped in the targets used in this experiment.

The muonic x rays resulting from an absorption of a muon in the target were detected by a scintillation spectrometer.⁴ The spectrometer consisted of a center crystal of NaI(Tl) (counter 8, $2\frac{1}{2}$ in. in diameter and 6 in. long) enclosed in an annulus of NaI(Tl). The annulus (counter 9, 8 in. o.d. by 12 in. long) was operated in an anticoincidence mode to suppress those events in the center crystal in which some of the energy of the gamma ray escaped the center crystal.

The telescope of counters in Fig. 1 was used to identify the absorption of a muon in the target. A schematic diagram of the electronics is shown in Fig. 2. A coincidence between counters 2, 4, and 5 identified an incident charged particle of the beam. An anticoincidence in counter 6 was required to ensure that the charged particles came to rest in the target. An anticoincidence from counter 7 was also required to guarantee that the NaI counter was not analyzing charged-particle events. Counter 3 was a Čerenkov detector operated in anticoincidence to eliminate events associated with the electrons in the beam. Some of the graphite was placed in front of the Čerenkov detector to slow the muons to an energy below the threshold detection level for muons for the Čerenkov detector. A “ μ -stop” pulse corresponding to coincidence (2,4,5; $\bar{3},\bar{6},\bar{7}$) was fed into one side of a 2-parameter system.⁵ A pulse from the scintillation spectrometer (No. 8) was fed to the other side of the 2-parameter circuit. The coincidence between the “ μ -stop” pulse and counter 8 in anticoincidence with counter 9 allowed the pulse

† Work supported by the U. S. Office of Naval Research and the U. S. Atomic Energy Commission.

* Present address: Brooklyn College, Brooklyn, New York.

‡ National Science Foundation fellow.

¹ H. L. Anderson, C. S. Johnson, E. P. Hincks, S. Raboy, and C. C. Trail, *Phys. Letters* **6**, 261 (1963).

² G. Culligan, H. Hinterburger, H. Øverås, V. L. Telegdi, and R. Winston, *Rev. Sci. Instr.* (to be published).

³ G. Culligan, R. A. Lundy, V. L. Telegdi, R. Winston, and D. D. Yovanovitch, *Rev. Sci. Instr.* (to be published).

⁴ C. C. Trail and S. Raboy, *Rev. Sci. Instr.* **30**, 425 (1959).

⁵ M. G. Strauss, *Proceedings of the Conference on the Utilization of Multiparameter Analyzers in Nuclear Physics, 1962, CU(PNPL)-227*, p. 95 (unpublished).

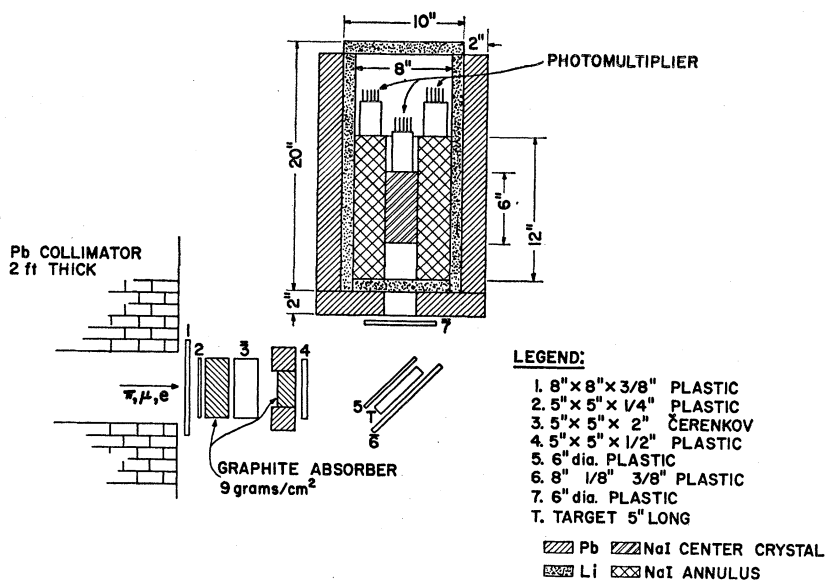

Fig. 1. Physical arrangement of apparatus for measurement of muonic x rays. An x-ray event which is analyzed consists of coincidence (245367; 89). A calibration event consists of coincidence (89; 157). Counter 8 is center crystal of NaI. Counter 9 is Annulus of NaI.

from No. 8 to pass through a linear gate in the 2-parameter system to a multichannel analyzer.

Because of the high counting rate in the annulus, about 30 000 counts/sec, the pulses from counter 9 were fed into a normally closed gate (external to the 2-parameter system) which was opened by signals from the center crystal (No. 8). This pulse was fed to the

2-parameter system with veto power over events from counter 8.

Pulses corresponding to coincidences between counters 1 and 2 were used to monitor the cyclotron beam. In the diagram all amplifiers, mixers, coincidence circuits, and multiplexers (unless otherwise specified) were the Barna-type transistorized units⁶ now in

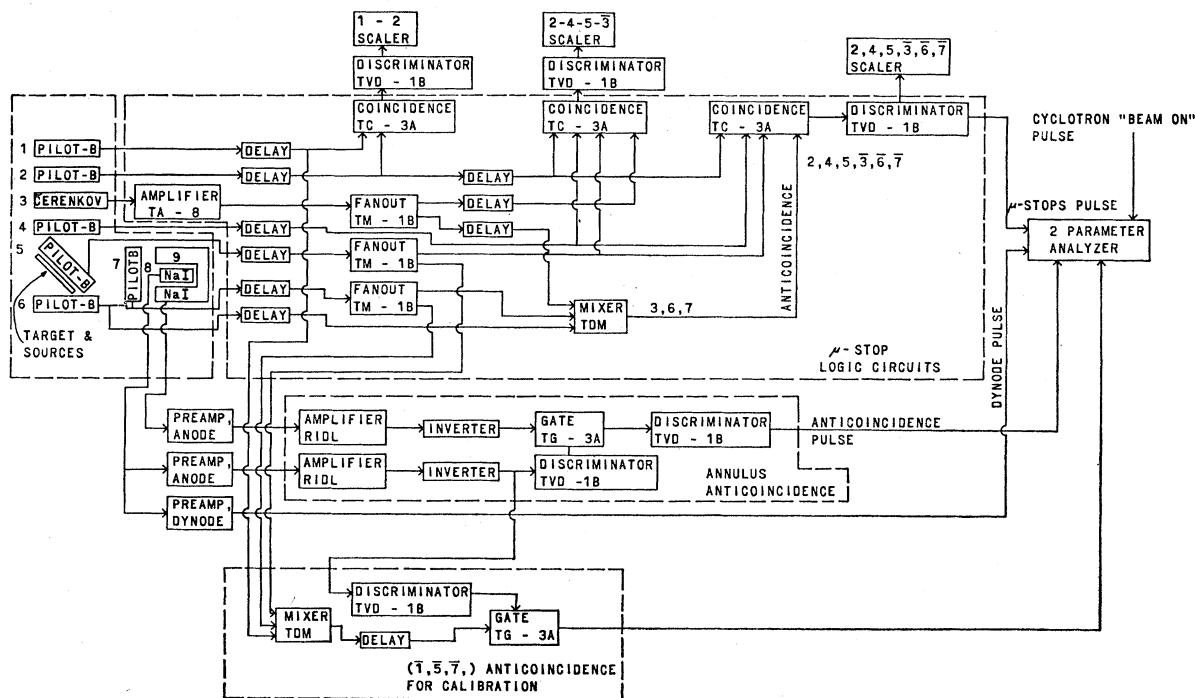
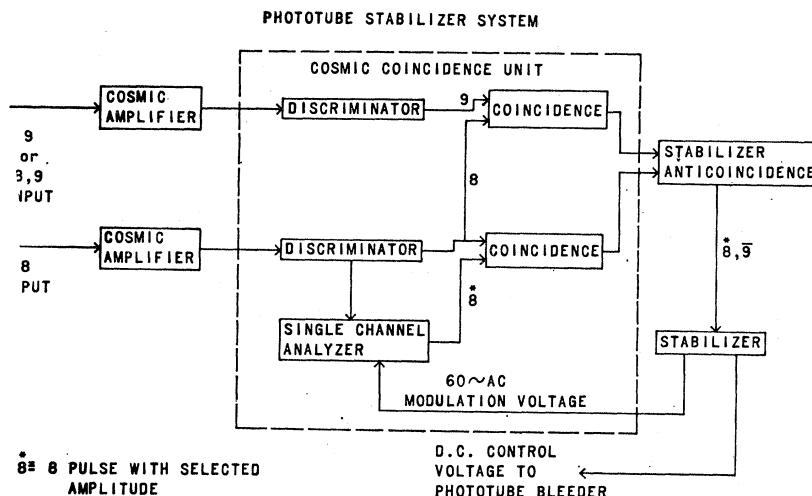

Fig. 2. Schematic diagram of circuitry to identify x rays associated with stopped muons.

⁶ A. Barna, J. H. Marshall, and M. Sands, Nucl. Instr. Methods 7, 124 (1960); California Institute of Technology Synchrotron Laboratory report No. CTSL-17 (unpublished); A. Barna and J. H. Marshall, California Institute of Technology Synchrotron Laboratory report No. CTSL-18 (unpublished).

FIG. 3. Schematic diagram of stabilizer circuit.



standard use at the Chicago synchrocyclotron. The RIDL amplifiers used in the 8-9 gate circuit were model 30-3.

In an attempt to make the system operate under identical conditions for both calibration and muonic runs, the analyzer itself was gated by a pulse from the cyclotron control system so that the events stored by the analyzer occurred during the most intense portion of the muonic beam. This point will be discussed more fully below. The pulses to be analyzed, whether calibration or muonic x-ray pulses, passed through the linear gate of the 2-parameter system which was opened by a pulse from a coincidence system in the 2-parameter circuits. We thus avoided uncertainties about level or gain shifts in the linear gate.

All muonic runs were carried out with the calibration sources present and all calibrations were performed with the beam on at full strength. During calibration runs, the requirement of a "μ stop" was removed and beam-associated events were vetoed by coincidence pulses from counters 1, 5, or 7. Such veto pulses were formed by mixing pulses 1, 5, and 7 and feeding the pulses into a normally closed gate. This gate was opened by properly delayed 8 pulses so that the number of 1, 5, and/or 7 pulses gated through was a maximum. We required the $\bar{7}$ condition for the calibration in order to simulate the conditions of data-taking during the x-ray run. The vetoes from counters 1 and 5 served to clean up the calibration spectra.

To reduce the drift in gain of the central phototube as a function of time, a DeWaard⁷ stabilizing circuit (Fig. 3) was used. This circuit stabilizes by monitoring the position of a photopeak which is present in the pulse-height spectrum. Any change in the photopeak position results in a change in the dc voltage applied to

the phototube that restores the position of the photopeak being monitored.

The photopeak position was monitored by switching a single-channel-analyzer window alternately along one edge of the photopeak and then along the other edge. An inequality in the number of counts was converted to a dc correction voltage. The switching rate was 60 cps, which was sufficiently different from the basic cyclotron cycle rate of about 70 cps to avoid correlation or interference between the switching rate and the cyclotron burst rate. An 80-sec time constant was used on the output to reduce statistical fluctuations.

The 662-keV gamma ray of Cs^{137} was used for stabilization. It was also used as a calibration line. We required the stabilization circuit to work on pulses from the center crystal (counter 8) in anticoincidence with pulses from the annulus (counter 9). This improved the stabilizing action by reducing the background under the photopeak.

The basic synchrocyclotron cycle rate, controlled by a rotating condenser system, was about 70 cps. The output beam from the machine was spread by a stochastic system such that the particle burst rate from

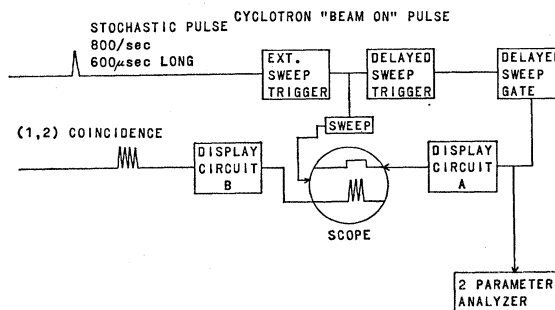

FIG. 4. Schematic diagram of circuit to provide a gating pulse synchronized with the cyclotron pulse.

⁷ H. DeWaard, *Nucleonics* 13, 36 (July 1955).

TABLE I. Positions (in the two banks) of the full-energy peaks of the calibration gamma rays.

Run No.	Peak position of 898-keV gamma ray		Peak position of 662-keV gamma ray		Peak position of 411-keV gamma ray	
	Bank 1	Bank 2	Bank 1	Bank 2	Bank 1	Bank 2
448	135.76 ±0.05	135.73±0.04	99.29±0.07	99.32±0.06	60.86±0.03	60.89±0.04
450	136.08 ±0.04	136.00±0.05	99.48±0.07	99.42±0.06	60.93±0.06	60.94±0.05
452	136.87 ±0.04	137.07±0.05	100.04±0.06	100.17±0.05	61.44±0.05	61.32±0.05
454	136.651±0.024	136.74±0.05	99.97±0.05	100.04±0.05	61.29±0.05	61.29±0.05
456	136.35 ±0.04	136.03±0.03	99.78±0.06	99.48±0.05	61.38±0.05	61.11±0.05
458	136.35 ±0.04	136.23±0.04	99.76±0.07	99.65±0.04	61.19±0.04	61.21±0.05
460	136.420±0.023	136.56±0.04	99.87±0.07	99.90±0.08	61.22±0.06	61.16±0.06
462	136.69 ±0.04	136.74±0.04	99.97±0.07	100.01±0.08	61.30±0.07	61.10±0.05
470	136.257±0.028	136.28±0.04	99.60±0.07	99.70±0.05	60.92±0.05	61.07±0.08
472	136.43 ±0.04	136.37±0.04	99.71±0.06	99.69±0.08	61.07±0.05	61.10±0.06
474	135.45 ±0.04	136.17±0.03	99.07±0.05	99.56±0.08	60.71±0.03	60.74±0.07

the machine was about 800 cps and the duty cycle was about 40–50%.

Since the muonic x rays were counted only during cyclotron “on” time, it was deemed advisable to take the calibration runs under the same conditions. Otherwise, changes in the crystal counting rate between the periods when the cyclotron beam was on and when it was off might shift the gain of the phototube system and affect the measured positions of the calibration lines. To prevent this, the multichannel analyzer was gated “on” for the x-ray measurements, and the calibration runs were gated “on” during the maximum particle rate of the cyclotron beam.

A delayed sweep system in an oscilloscope was controlled by a pulse from the cyclotron control system; by adjusting the sweep speeds and delays, it was possible to select any portion of the cyclotron cycle desired. Also, by observing the (1,2) counting rate on the oscilloscope screen, the beam emission cycle could be determined directly. A block diagram of the cyclotron gate system is shown in Fig. 4.

III. PROCEDURE

The data were collected in a manner similar to that used in Ref. 1. The targets were in the form of CaCO_3 powder. The Ca^{40} sample contained natural calcium

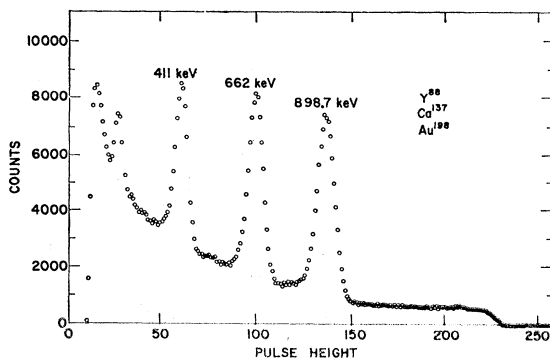

FIG. 5. Spectrum of calibration gamma rays used for the measurement.

which was 97% Ca^{40} and 2% Ca^{44} . The Ca^{44} sample was obtained from the Stable Isotopes Division of ORNL; it contained 95% Ca^{44} and 5% Ca^{40} . Both samples were contained in Lucite-filled boxes 0.81 in. thick and 2.5 in. in diameter, two boxes being used for each target. Both targets were of the order of 5 g/cm² thick.

Before each x-ray run, the two banks of the analyzer were calibrated with the 898-keV gamma rays⁸ from Y^{88} , the 662-keV gamma ray⁹ from Cs^{137} , and the 412-keV gamma ray¹⁰ from Au^{198} . During the calibration run, data were collected in one bank of 256 channels for 15 min (run A) and then in the second bank for 15 min (run B). This pattern was repeated in an ABBA fashion for a total time of about 1 h. During the calibration runs, the muon beam was kept on the target and the analyzer was gated by the cyclotron pulses and the (1,5,7) veto pulses. Although it was not the purpose of this experiment to measure the energy of the x ray, this calibration procedure was used to ensure that no differences were present in the two banks of the analyzer.

After a calibration run, an x-ray run was made. The

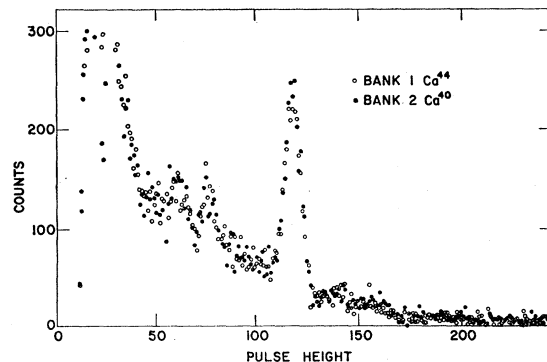

FIG. 6. Spectrum of muonic x rays from the sample enriched in Ca^{44} superimposed on that from natural Ca.

⁸ J. E. Monahan, S. Raboy, and C. C. Trail, Phys. Rev. **123**, 1373 (1961).

⁹ D. E. Muller, H. C. Hyat, D. J. Klein, and J. W. M. DuMond, Phys. Rev. **88**, 775 (1952).

¹⁰ B. Hamermesh and R. K. Smither, Ann. Phys. (N.Y.) **13**, 307 (1961).

TABLE II. Peak positions of the K_{α} x rays from the Ca⁴⁰ sample and the Ca⁴⁴ sample.

Run No.	Peak position, Ca ⁴⁰ sample (channels)	Peak position, Ca ⁴⁴ sample (channels)	Difference in peak position between samples $E_{K_{\alpha}}(\text{Ca}^{40}) - E_{K_{\alpha}}(\text{Ca}^{44})$		Weight (channels) ⁻²
			(channels)	(keV)	
	Bank 2	Bank 1			
449	117.68±0.17	117.66±0.15	+0.02±0.23	+0.13±1.5	18.9
453	118.16±0.17	118.18±0.23	-0.02±0.29	-0.13±1.9	11.9
459	118.20±0.16	118.04±0.11	+0.16±0.19	+1.0 ±1.2	28.0
471	118.42±0.18	118.19±0.13	+0.23±0.22	+1.5 ±1.4	20.7
	Bank 1	Bank 2			
451	118.09±0.13	117.78±0.16	+0.31±0.21	+2.0 ±1.3	22.7
455	118.26±0.15	118.21±0.10	+0.05±0.18	+0.32±1.2	31.0
461	118.03±0.17	118.06±0.12	-0.03±0.21	-0.19±1.4	22.7
473	118.29±0.17	118.02±0.14	+0.27±0.22	+1.8 ±1.4	20.7

Weighted mean: $E_{K_{\alpha}}(\text{Ca}^{40}) - E_{K_{\alpha}}(\text{Ca}^{44}) = 0.9 \pm 0.3$ keV
Arithmetic mean: $E_{K_{\alpha}}(\text{Ca}^{40}) - E_{K_{\alpha}}(\text{Ca}^{44}) = 0.9 \pm 0.3$ keV
These means include a 7% correction for the isotopic abundances in the two samples.

muon-stop pulse requirement was imposed on the analyzer, and x-ray data were accumulated from one of the calcium samples in the first bank of the analyzer (run A). After 15 min the second sample was placed in the target position and the x-ray data from it were accumulated for 15 min in bank 2 of the analyzer (run B). This procedure was repeated again in an ABBA manner for a total accumulation time of approximately 7 h. Fifteen such runs were taken, but problems with the cyclotron and the detecting equipment developed during seven of the runs so that these could not be used for analysis. The remaining eight runs were used in the analysis.

By suitably delaying the pulses from counter 8, we determined the spectra of accidental events in each sample. Our coincidence resolution time of about 34 nsec precluded measurable distortion from accidental coincidences. By suitably delaying the μ -stop pulse, we obtained the spectrum of gamma rays resulting from the capture of the muons in each isotope. We increased our resolving time to 150 nsec to get the capture-gamma-ray data. No gamma-ray peaks in the energy region of the x rays were observed in either sample. Neither the accidental coincidences nor the capture gamma rays caused any difficulties in the analysis of the data. These auxiliary spectra provided a convenient means of removing background from the muonic x-ray data.

IV. DISCUSSION OF RESULTS

Table I compares the calibration lines of the two banks; a typical calibration spectrum in one bank is presented in Fig. 5. Figure 6 shows a typical muonic x-ray spectrum and Table II summarizes the x-ray data.

The photopeaks for both calibration runs and x-ray runs were analyzed by making a χ^2 -minimization fit to the corrected data with a Gaussian.¹¹ The subtraction

techniques used to get the corrected data are described in detail in Ref. 11. The peak positions given in Tables I and II are the results of these fits. The uncertainties associated with the peak positions were obtained as part of the computational program and include the uncertainties arising from the "goodness of fit" as well as the uncertainties from the statistical significance of the data.

From Table I we see that the average differences in peak positions for the calibration lines are +0.05, -0.05, and +0.04 channels for the 898-, 662-, and 412-keV lines, respectively. The error assigned to these average differences is about ± 0.05 channels. This error is primarily a systematic error which is inferred from the individual fits to the full-energy peaks of the calibration lines. We feel that 0.05 channel represents the experimental limit to the separations we might hope to measure.

Table II lists the peak positions for the K_{α} x rays for the two samples, the differences (in channels and in keV), and the weights associated with each determination. The weights are determined by the square of the reciprocals of the uncertainties in the differences in the peak positions. It is interesting to note that the weights vary only by a factor of about 2.5, whereas in Ref. 1 the variation was as great as a factor of 9. The variation in the weights of the data in Ref. 1 was attributed to the variation in gain experienced during that experiment. Here the weights are more nearly equal and the result is the same whether one takes a weighted or arithmetic average of the data.

It is useful to point out here that the x-ray spectra of Ref. 1 had peak-to-valley ratios of about 2:1. In the present experiment, the ratios were about 4:1. This improvement in the quality of the spectra was made possible by the intense muon beam from the muon channel. This intense beam permitted the counter to be mounted at 90° to the beam and the x rays to be collimated onto the center crystal. Also the center crystal was positioned in the middle of the annulus, about 3 in.

¹¹ R. T. Julke, J. E. Monahan, S. Raboy, and C. C. Trail, Argonne National Laboratory Report ANL-6499 (unpublished).

from the entrance aperture. In Ref. 1, for intensity reasons, the spectrometer was mounted at 45° to the main beam and the center crystal was placed flush with the entrance aperture of the annulus. The arrangement in the present experiment gives a much cleaner spectrum.

In each experiment, we had eight runs to measure the differences. In Ref. 1 the amplitude of each peak was about 80 counts. In the present experiment the amplitude of each peak was about 200 counts.

As noted in Table II, we find the energy of the $2p \rightarrow 1s$ transition in muonic Ca^{40} is 0.9 ± 0.3 keV more energetic than that in muonic Ca^{44} .

If the radius of the charge distribution was the same for the Ca^{40} and Ca^{44} nuclei, the $2p \rightarrow 1s$ transition in Ca^{44} would be 0.2 keV more energetic than that in Ca^{40} because of the reduced mass effect.

Unfortunately, the result of this experiment is not in agreement with the earlier result of Ref. 1. We believe that the present experiment is superior in that we achieved a much more stable detecting system, that the quality of the spectra is superior, that possible sources of systematic error have been eliminated, and that greater statistical accuracy has been attained.¹²

ACKNOWLEDGMENTS

We wish to express our appreciation for the help we received in various forms from G. Culligan, W. Greenhow, H. Hinterberger, J. Peregrin, B. Sherwood, and V. L. Telegdi.

¹² We have been informed by Dr. C. Missim-Sabat that the group at Columbia University has made a similar measurement and has obtained 0.65 ± 0.27 keV for the difference between the $2p \rightarrow 1s$ transitions in muonic Ca^{40} and Ca^{44} . We appreciate Dr. Missim-Sabat's communicating his result to us prior to publication.

Angular Correlation Measurements in the Decay of Cd^{115m}

V. R. PANDHARIPANDE, R. P. SHARMA, AND GIRISH CHANDRA

Tata Institute of Fundamental Research, Bombay, India

(Received 6 April 1964)

Levels in In^{115} at 650, 930, 1125, 1285, 1420, and 1540 keV are populated in the decay of Cd^{115m} (43 days). The experimentally determined coefficients of the gamma-gamma angular correlation function for the cascades 485-930 and 160-1125 keV are $A_2 = -0.023 \pm 0.005$, $A_4 = 0.013 \pm 0.012$; $A_2 = -0.107 \pm 0.011$, $A_4 = 0.021 \pm 0.017$, respectively. The coefficient of the $\beta-\gamma$ directional correlation function between the unique first forbidden beta transition and the following 930-keV gamma ray is found as $A_2 = 0.0088 \pm 0.0076$. Spin assignments for the excited states in In^{115} , which are consistent with the experimental results, are $7/2$ (930 keV), $11/2$ (1125 keV), $9/2$ (1280 keV) and $9/2$ (1420 keV). The quadrupole-dipole mixing has been determined for the cascading gamma rays. From delayed-coincidence measurements, the half-lives of 930- and 1420-keV levels were found to be shorter than 3×10^{-10} sec and 1.1×10^{-9} sec, respectively.

I. INTRODUCTION

THE decay of Cd^{115m} with a half-life of 43 days to In^{115} has been studied previously¹⁻³ by using scintillation coincidence techniques and magnetic beta-ray spectrometer. The decay scheme is well established and is shown in Fig. 1. Spin and parity assignments to levels of In^{115} have been made on the basis of calculated $\log ft$ values for the beta transitions which are classified as first forbidden types. The measured spin and parity of Cd^{115m} is $11/2^-$,⁴ which correspond to an $h_{11/2}$ single-particle state for the odd neutron and those of In^{115} is $9/2^+$,⁵ indicating a $g_{9/2}$ state for the proton hole. The beta transition feeding the 930-keV level has been shown^{2,3} to be of unique first forbidden type. Nothing definite is known about the multi-

polarities of the gamma transitions as no internal conversion coefficients have been measured due to the intense beta transition to the ground state. The angular correlation between the 480- and 930-keV gamma rays has been measured by Varma and Mandeville¹ and by Van Der Kooi *et al.*,⁶ but their results are not in good agreement with each other as is evident from Table I. The latter group concludes that the quadrupole ad-

TABLE I. Angular correlation coefficients for the 480-930-keV cascade.

Authors	A_2	A_4
Varma ^a	0.017	0.016
Van Der Kooi ^b	-0.022 ± 0.006	0.029 ± 0.011
Present work	-0.023 ± 0.005	0.013 ± 0.012

^a Reference 1.

^b Reference 6.

¹ J. Varma and C. E. Mandeville, Phys. Rev. **97**, 977 (1955).

² O. E. Johnson and W. G. Smith, Phys. Rev. **116**, 992 (1959).

³ R. P. Sharma and H. G. Devare, Phys. Rev. **131**, 384 (1963).

⁴ B. Perry, M. N. McDermott, and R. Novick, Bull. Am. Phys. Soc. **7**, 533 (1962).

⁵ J. E. Mack, Rev. Mod. Phys. **22**, 64 (1950).

⁶ J. B. Van Der Kooi, H. J. Van Den Bold, and P. M. Endt, Physica **29**, 140 (1963).