

Mössbauer Effect Studies of the 103-keV Level on $\text{Eu}^{153}\dagger$

U. ATZMONY, A. MUALEM, AND S. OFER

Department of Physics, The Hebrew University, Jerusalem, Israel

(Received 9 July 1964)

The recoilless absorption spectra of the 103-keV γ rays from Eu^{153m} in Eu^{153} situated in europium oxide and in europium iron garnet were measured at 20°K. The source used was Sm^{153} in the form of an oxide at 20°K. With the Eu_2O_3 absorber an unsplit absorption line with (2.1 ± 0.4) mm/sec width at half-maximum was obtained. From the hyperfine Zeeman splittings obtained with the europium iron garnet absorber, a value of $(+2.01 \pm 0.09)$ nm. was found for the magnetic moment of the 103-keV level of the Eu^{153} . This value is in very good agreement with the predictions of the unified model.

INTRODUCTION

THE recoilless absorption spectra of the 103-keV γ rays from Eu^{153m} [$\tau = (5.1 \pm 0.5) \times 10^{-9}$ sec]¹ in Eu^{153} situated in europium oxide and in europium iron garnet (EuIG) were measured at 20°K. The magnitude of the effective magnetic fields (H_{eff}) acting on the Eu nucleus in EuIG as a function of temperature has already been previously determined from recoilless absorption measurements of the 21.7-keV γ rays of $\text{Eu}^{151,2,3}$. These measurements strongly supported the hypothesis that the admixture of the excited 7F_1 state of the Eu^{3+} ion in EuIG into the 7F_0 ground state produced by the exchange interaction, accounts essentially for the behavior of H_{eff} acting on the Eu nucleus in EuIG below its Curie temperature (about 550°C).⁴

The main purpose of the present work was to derive the value of the magnetic moment of the 103-keV level of Eu^{153} from the hyperfine Zeeman splittings of the recoilless absorption spectrum of the 103-keV γ rays of Eu^{153} in EuIG. The value of H_{eff} in EuIG at low temperatures ($\sim 600 \times 10^3$ Oe) is higher than in any other known ferrimagnetic compound of europium (in Eu metal, EuO, and EuS, the values of H_{eff} lie between 260 to 330 kOe).⁵ The chances of getting resolved absorption lines were therefore much better for an EuIG absorber than for any other absorber and therefore the present measurements were carried out with an EuIG absorber. The present experimental results indeed indicate that there is very little chance of obtaining resolved lines in the absorption spectrum of any other known ferrimagnetic compound of europium.

The spin and parity of the ground state of Eu^{153} are $\frac{5}{2}+$.⁶ The value of its magnetic moment is (1.507 ± 0.003) nm⁷ and of its quadrupole moment is

(2.4 ± 0.2) b.⁸ The spin and parity of the 103-keV level are $\frac{3}{2}+$. The 103-keV transition is predominantly $M1$.⁶ Eu^{153} is a strongly deformed nucleus ($\delta \sim 0.31$ for its ground state⁹). The value obtained in the present work for the magnetic moment of the 103-keV level is in very good agreement with the predictions of the unified model.⁹

EXPERIMENTAL DETAILS

The source used was Sm^{153} in the form of Sm_2O_3 . It was produced by neutron irradiation of natural Sm_2O_3 . 97-keV γ rays are also emitted in the decay of Sm^{153} , but their intensity relative to the 103-keV γ rays is only 2%⁶ and their effect on the absorption spectra was assumed to be negligible. The absorbers used were 0.15-g/cm² Eu_2O_3 and 1.9-g/cm² EuIG. The 103-keV radiation was detected by a NaI(Tl) scintillation counter. The absorption as a function of relative velocity between source and absorber was recorded automatically on a 400-channel pulse-height analyzer. A block diagram of the electronic system is shown in Fig. 1. The system was similar to those described in previous works,^{2,10} except that the modulation signal was taken from a pickup coil mounted on the loudspeaker and not from the driving signal after an appropriate phase change. A scale of velocities was established by using as a calibration the absorption spectrum of $\alpha\text{-Fe}_2\text{O}_3$, which has been previously investigated.¹¹ For some of the measurements velocities extending to few cm/sec were needed. On the other hand, the $\alpha\text{-Fe}_2\text{O}_3$ spectrum extends to about 1 cm/sec. In order that the calibration should cover the required range, the following procedure was used: The ac voltage applied to the loudspeaker was increased and the fraction of the pickup signal used for modulation was decreased. The ratio of the fractions of the pickup signals that were used for modulation in the calibration with $\alpha\text{-Fe}_2\text{O}_3$ and in the actual measurement was measured accurately using a helipot potentiometer. The velocity

† This work is supported in part by the U. S. National Bureau of Standards.

¹ P. Reyes-Suter and T. Suter, *Arkiv Fysik* **20**, 399 (1961); T. D. Nainan, *Phys. Rev.* **123**, 1751 (1961).

² I. Nowik and S. Ofer, *Phys. Rev.* **132**, 241 (1963).

³ D. Kienle, *Rev. Mod. Phys.* **36**, 372 (1964).

⁴ G. Gilat and I. Nowik, *Phys. Rev.* **130**, 361 (1963).

⁵ D. A. Shirley, R. B. Frankel, and H. H. Wickman, *Rev. Mod. Phys.* **36**, 392 (1964).

⁶ T. Suter, P. Reyes-Suter, S. Gustafsson, and I. Marklund, *Nucl. Phys.* **29**, 33 (1962).

⁷ M. Pichanick, P. G. H. Sandars, and G. U. Woodgate, *Proc. Roy. Soc. (London)* **257**, 277 (1960).

⁸ K. Krebs and R. Winkler, *Naturwiss.* **47**, 490 (1960).

⁹ B. R. Mottelson and G. Nilsson, *Kgl. Danske Videnskab. Selskab, Mat. Fys. Skrifter* **1**, No. 8 (1959).

¹⁰ R. Bauminger, S. G. Cohen, A. Marinov, and S. Ofer, *Phys. Rev.* **122**, 743 (1961).

¹¹ O. C. Kistner and A. W. Sunyar, *Phys. Rev. Letters* **4**, 421 (1960).

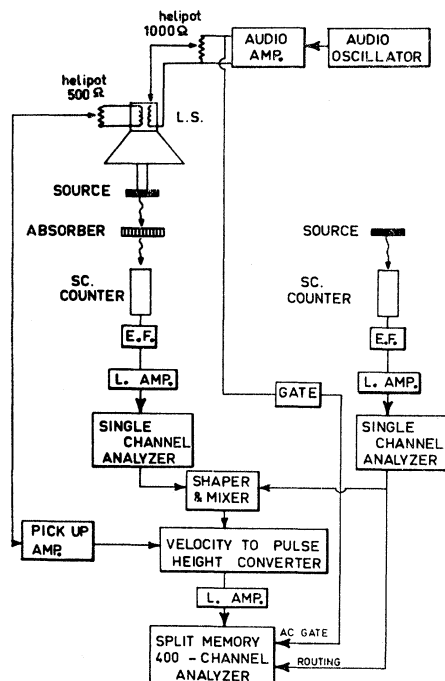

FIG. 1. Block diagram of the electronics used for the automatic measurement of the recoilless absorption as a function of relative velocity between source and absorber.

scales were inversely proportional to the fractions used which were measured by the helipot readings.

All measurements were carried out with both source and absorber at 20°K. The liquid-hydrogen cryostat used is shown in Fig. 2.

EXPERIMENTAL RESULTS

The spectrum obtained with the Eu_2O_3 absorber is shown in Fig. 3. The width of the absorption line at half-maximum is 2.1 ± 0.4 mm/sec. If we assume that the emission and the absorption lines have the same widths, our results show that the widths at 20°K are about 2.5 times the natural widths, as obtained from the lifetime of the 103-keV level. Assuming that the probability for recoil-free emission f is the same as the probability for recoil-free absorption, it is possible to calculate f at 20°K from the size and shape of the absorption spectrum obtained. The value derived for f at 20°K is $(5 \pm 1.0)\%$. From this value, we obtain a Debye temperature of about 225°K, using the Debye-Waller relation.¹² This value is very close to those obtained for other rare-earth oxides.^{13,14}

In Fig. 4(A) the absorption spectrum of EuIG is shown. Four resolved absorption lines are seen. The

¹² *The Mössbauer Effect* edited by H. Frauenfelder (W. A. Benjamin Inc., New York, 1962), p. 30.

¹³ S. Ofer, P. Avivi, R. Bauminger, A. Marinov, and S. G. Cohen, *Phys. Rev.* **120**, 406 (1960).

¹⁴ D. A. Shirley, M. Kaplan, R. W. Grant, and D. A. Keller, *Phys. Rev.* **127**, 2097 (1962).

selection rules for a pure $M1$ transition between levels with spins $\frac{5}{2}$ and $\frac{3}{2}$ permit 12 transitions between the sublevels. The fact that only four resolved lines are obtained shows that the gyromagnetic ratios of the ground state and the 103-keV state are such that many of the possible absorption lines overlap. A preliminary analysis of the spectrum showed that the absorption spectrum is consistent only with the assumption that the ratio of the g factors of the excited state and the ground state, respectively, is about 2. Following this interpretation the transitions between the sublevels are classified in Table I, according to their position in the absorption spectrum. The calculated relative transition probabilities are also given in this table. The absorption lines corresponding to transitions $\frac{1}{2} \rightarrow \frac{3}{2}$ and $-\frac{1}{2} \rightarrow -\frac{3}{2}$ were not detected because of their low relative intensities.

In the final analysis of the results a possible axially

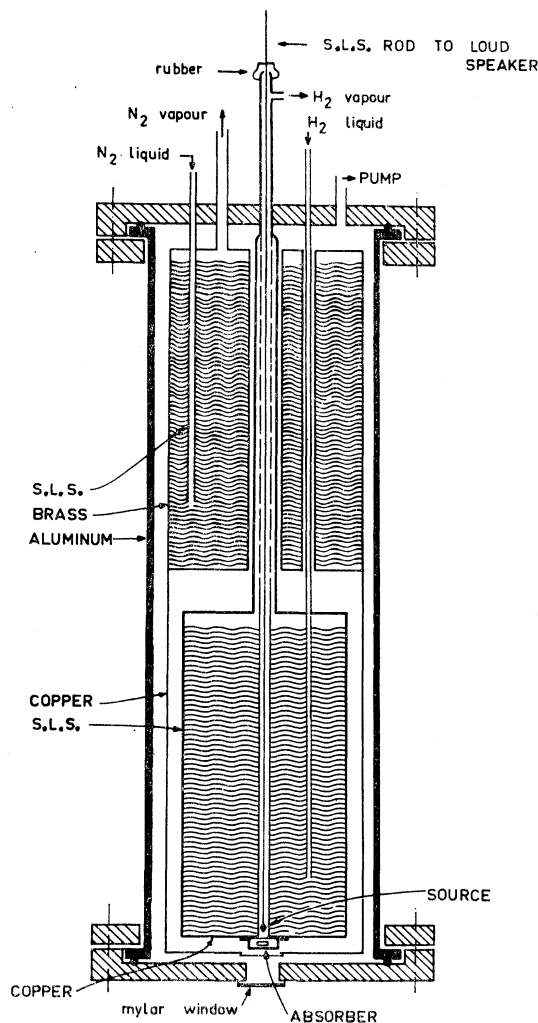

FIG. 2. Experimental arrangement for carrying out recoil-free absorption measurements with source and absorber at liquid-hydrogen temperature.

symmetric quadrupole interaction was taken into account and it was assumed that each level is split according to the following expression¹⁵

$$W = -mg\mu_n H_{\text{eff}} + \frac{1}{4}eqQ[3m^2 - I(I+1)]/[I(2I-1)],$$

where g is the gyromagnetic ratio of the level and Q its quadrupole moment. In addition, a possible shift ΔE between the centroids of the absorption line and the emission line was taken into account. From the analysis of the experimental results a value of 2.2 ± 0.3 was derived for the ratio g_1/g_0 , where g_1 and g_0 are the gyromagnetic ratios of the 103-keV level and the ground level, respectively. The analysis also indicated that the value of H_{eff} acting on the Eu nucleus at 20°K is about 600×10^3 Oe, in agreement with the value of $(585 \pm 15) \times 10^3$ Oe derived from the recoilless absorption measurements using the 21.6-keV γ rays of $\text{Eu}^{151,2,3}$. The magnetic moment of the 103-keV level can be determined quite precisely from the present results if in the analysis of the results we rely on the value of H_{eff} derived from the absorption measurements of the 21.6-keV γ rays of Eu^{151} in EuIG. Then, a value of 2.22 ± 0.08 is found for g_1/g_0 . The magnetic moment of the ground state was measured by Pichanick *et al.* and found to be $(1.507 \pm 0.003) \text{ nm}^7$ and therefore our results show that the magnetic moment of the 103-keV level is $(+2.01 \pm 0.09) \text{ nm}$. The results also indicate that the absolute values of eqQ/h for both the 103-keV level and the ground level are smaller than 200 Mc/sec. The value of $\Delta E/h$ was found to be $(0 \pm 20) \text{ Mc/sec}$. In Fig. 4(B), a reconstruction of the absorption spectrum of EuIG at 20°K, assuming a ratio of 2.2 for g_1/g_0 and neglecting the quadrupole interactions and the isomeric shift is shown. In the reconstruction, the theoretical relative transition probabilities were taken into account and it was assumed that each line had the

TABLE I. Identification of observed transitions between nuclear Zeeman levels.

Peak observed	Transition between Zeeman substates	Relative intensity
<i>a</i>	$\frac{1}{2} \rightarrow \frac{3}{2}$	0.1
<i>b</i>	$\frac{3}{2} \rightarrow \frac{5}{2}$	0.4
	$-\frac{1}{2} \rightarrow \frac{1}{2}$	0.3
<i>c</i>	$\frac{5}{2} \rightarrow \frac{7}{2}$	1
	$\frac{3}{2} \rightarrow \frac{5}{2}$	0.6
	$-\frac{1}{2} \rightarrow \frac{1}{2}$	0.6
<i>d</i>	$\frac{7}{2} \rightarrow \frac{9}{2}$	0.6
	$\frac{5}{2} \rightarrow \frac{7}{2}$	0.6
	$-\frac{1}{2} \rightarrow \frac{1}{2}$	1
<i>e</i>	$\frac{9}{2} \rightarrow \frac{11}{2}$	0.3
	$-\frac{1}{2} \rightarrow \frac{1}{2}$	0.4
<i>f</i>	$-\frac{1}{2} \rightarrow -\frac{3}{2}$	0.1

¹⁵ R. Bauminger, S. G. Cohen, A. Marinov, and S. Ofer, Phys. Rev. Letters 6, 467 (1961).

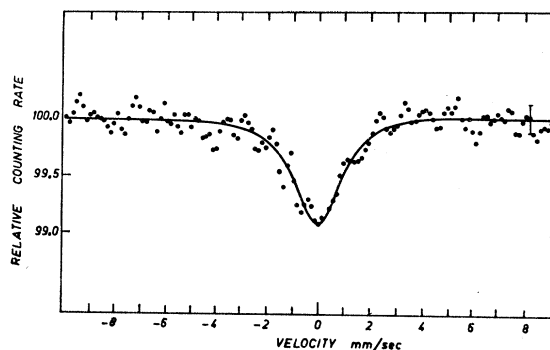

FIG. 3. The absorption by Eu_2O_3 at 20°K of the 103-keV γ ray emitted from an oxide source of Sm^{153} at 20°K, as a function of relative velocity between source and absorber.

same shape as the absorption spectrum of Eu_2O_3 at 20°K (Fig. 3). The agreement between the experimental and reconstructed spectra is seen to be excellent.

DISCUSSION

According to the unified model,⁹ the ground state and the 103-keV state of Eu^{153} are $[413, \frac{5}{2}^+]$ and $[411, \frac{3}{2}^+]$ Nilsson states, respectively. The magnetic moment of the 103-keV level can be calculated according to the unified model as a function of its deformation and for $\delta=0.31$ one obtains a value of 2.2 nm which is

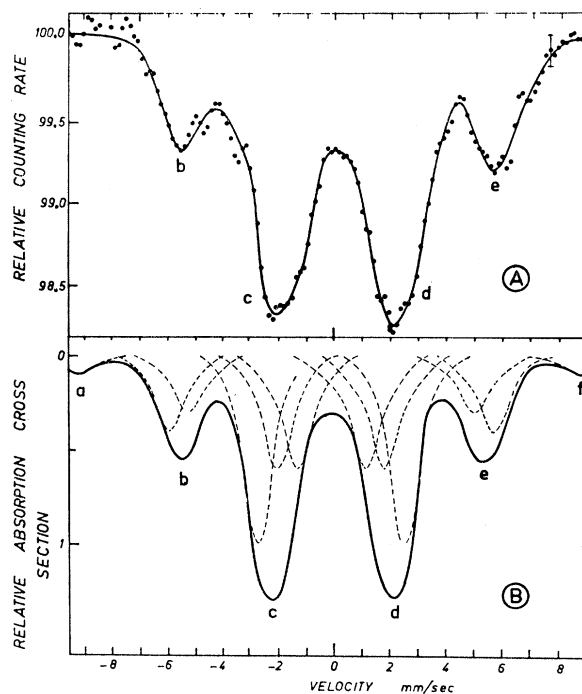

FIG. 4. (A) The absorption by europium iron garnet at 20°K of the 103-keV γ ray emitted in the decay of Sm^{153} , as a function of relative velocity between source and absorber. (B) Reconstructed absorption spectrum of EuIG at 20°K, assuming the splitting parameters obtained from the analysis of the experimental results and the theoretical transition probabilities.

in very good agreement with the present experimental results. The magnetic moment of the ground state of Tb^{159} , which is also probably a $[411, \frac{3}{2}^+]$ Nilsson state, was measured by Baker and Bleaney and found to be $(1.90 \pm 0.05) \text{ nm}^{16}$ (if Lindgren's values¹⁷ of $\langle 1/r^3 \rangle$ are used) which is very close to the present experimental value of the magnetic moment of the 103-keV level.

Gilat and Nowik calculated the effective electric field gradient at the Eu nucleus in EuIG, associated with the orientation of the orbital wave functions

¹⁶ J. M. Baker and B. Bleaney, Proc. Roy. Soc. (London) **A245**, 156 (1958).

¹⁷ I. Lindgren, Nucl. Phys. **32**, 161 (1962).

produced by the exchange interaction through the spin-orbit coupling. Their calculated value was $-55 \text{ Mc/sec per barn}$ at 20°K . For the ground state $Q=2.4 \text{ b}$ and therefore a value of about -130 Mc/sec is expected for eqQ_0 , neglecting other possible contributions to the electric field gradient.⁴ The present experimental upper limit of 200 Mc/sec for the absolute value of eqQ_0 is therefore not in contradiction with the theoretical prediction.

ACKNOWLEDGMENT

We would like to thank A. Mustachi for help in chemical problems.

Shapes of Allowed and Unique First-Forbidden β -Ray Spectra: In^{114} , K^{42} , Rb^{86} , Sr^{90} , and Y^{90}

H. DANIEL, G. TH. KASCHL, H. SCHMITT, AND K. SPRINGER

Max Planck Institute of Nuclear Physics, Heidelberg, Germany

(Received 29 July 1964)

The β -ray spectra of In^{114} , K^{42} , Rb^{86} , Sr^{90} , and Y^{90} (ground-state transitions) have been measured with the Heidelberg double-lens spectrometer. The allowed spectrum of In^{114} was found to have a purely statistical shape; the coefficient b of a possible b/W term turned out to be $b = (0.5 \pm 2.2) \times 10^{-2} mc^2$. The unique first-forbidden spectra of K^{42} , Rb^{86} , Sr^{90} , and Y^{90} were found to show very small but definite deviations from the simple unique shape.

I. INTRODUCTION

ACCORDING to the accepted theory of weak interaction, the shape of allowed spectra must be "allowed" or statistical, unless second-order terms contribute significantly. These second-order terms are (1) "regular" twice-forbidden contributions and (2) weak-magnetism terms.¹ Both kinds of terms have been observed. The largest deviation from the statistical shape was found²⁻⁹ in the decay of P^{32} and can fully be explained^{10,11} by the high ft value of this decay.

In the case of unique first-forbidden spectra, one expects a "unique" shape unless there are considerable (1) "regular" third-forbidden contributions and (2)

weak magnetism terms. The situation is, however, more complex.¹²

Previous work at laboratories in Heidelberg has verified the statistical shape for a number of allowed β -ray spectra.^{3,13-18} Similar results were obtained by other groups.^{2,7,8,19-21} These results are incompatible with the work of Langer and co-workers^{5,22-24} who have been reporting b/W type deviations from the statistical shape, with b values centered around $+0.3$. Such large

¹⁰ G. B. Henton and B. C. Carlson, ISC-1006 (1957) (unpublished).

¹¹ I. Iben, Phys. Rev. **109**, 2059 (1958).

¹² W. Bühring (private communication).

¹³ H. Daniel and U. Schmidt-Rohr, Nucl. Phys. **7**, 516 (1958).

¹⁴ H. Leutz, Z. Physik **164**, 78 (1961).

¹⁵ H. Daniel and Ph. Panussi, Z. Physik **164**, 303 (1961).

¹⁶ H. Daniel, O. Mehling, and D. Schotte, Z. Physik **172**, 202 (1963).

¹⁷ D. Schotte, Diplomarbeit Heidelberg, 1963 (unpublished).

¹⁸ H. Daniel, O. Mehling, P. Schmidlin, D. Schotte, and E. Thummernicht, Z. Physik **179**, 62 (1964).

¹⁹ F. Bonhoeffer, Z. Physik **154**, 62 (1959).

²⁰ I. Hofmann, SGAE-PH 13, Seibersdorf 1963 (unpublished).

²¹ H. Paul, F. P. Viehböck, P. Skarek, H. Bauer, I. Hofmann, and H. Wotke, Acta Phys. Austriaca **16**, 278 (1963).

²² J. H. Hamilton, L. M. Langer, and W. G. Smith, Phys. Rev. **112**, 2010 (1958); **119**, 772 (1960).

²³ J. H. Hamilton, L. M. Langer, and D. R. Smith, Phys. Rev. **123**, 189 (1961).

²⁴ D. C. Camp and L. M. Langer, Phys. Rev. **129**, 1782 (1963).

¹ M. Gell-Mann, Phys. Rev. **111**, 362 (1958).

² F. T. Porter, F. Wagner, Jr., and M. S. Freedman, Phys. Rev. **107**, 135 (1957).

³ H. Daniel, Nucl. Phys. **8**, 191 (1958).

⁴ R. L. Graham, J. S. Geiger, and T. A. Eastwood, Can. J. Phys. **36**, 1084 (1958).

⁵ O. E. Johnson, R. G. Johnson, and L. M. Langer, Phys. Rev. **112**, 2004 (1958).

⁶ D. Fehrentz and H. Daniel, Nucl. Instr. Methods **10**, 185 (1961).

⁷ R. T. Nichols, R. E. McAdams, and E. N. Jensen, Phys. Rev. **122**, 172 (1961).

⁸ P. Depommier and M. Chabre, J. Phys. Radium **22**, 656 (1961).

⁹ Ch'ing Ch'eng-Jui and L. S. Novikov, Zh. Eksperim. i Teor. Fiz. **42**, 364 (1962) [English transl.: Soviet Phys.—JETP **15**, 252 (1962)].