

Nuclear Quadrupole Interactions in Beryllium Oxide*

T. T. TAYLOR† AND T. P. DAS

Department of Physics, University of California, Riverside, California

(Received 15 July 1963; revised manuscript received 12 November 1963)

The importance of the contribution from higher multipole moments of oxygen ions to the electric field gradient at nuclei in a wurtzite-type ionic oxide, namely, beryllium oxide, is considered and, in particular, oxygen dipole moments are found to contribute significantly to the field gradient at beryllium ion sites. The dipolar polarizability of an oxygen ion bound in a beryllium oxide lattice is analyzed and a value of 2.19 \AA^3 is obtained. Using 7.0 \AA^5 for the quadrupolar polarizability of the same ion and considering the slight uncertainty associated with the sublattice displacement parameter u , the experimental quadrupole coupling constant for the Be^9 nuclei, $\pm 41 \pm 4 \text{ kc/sec}$, can be explained. The quadrupole coupling constant for O^{17} nuclei is also investigated and presented as a function of u . In this case, oxygen dipole moments do not contribute because of lattice symmetry; oxygen quadrupole moments do contribute, however.

I. INTRODUCTION

NUCLEAR magnetic resonance measurements in crystals without cubic symmetry yield^{1,2} the quadrupole coupling constant e^2qQ/h . In those cases where the local symmetry around the nucleus is less than threefold, the asymmetry parameter η may also be obtained provided the measurements are made on single crystals. Several examples of the calculation of electric field gradients in ionic crystals may be cited.³⁻⁹ Most of these involve the summing of contributions from the monopole moments of the ions and information on the degree of success of such calculations has often been obscured by the presence of structures such as ClO_3^- , BrO_3^- , NO_3^- , and others which cannot be adequately described by a monopole moment alone.

A few studies such as those of the metal resonances^{3,8,10,11} in BeO , Al_2O_3 , and Fe_2O_3 , the niobium resonance⁷ in KNbO_3 , and the halogen resonances⁹ in a number of metal halides, have involved lattices with only monatomic ions but even in these cases, the sums over monopole contributions, where attempted, have failed to explain the observed coupling constants. It has been suggested that covalent bonding between cations and anions is responsible for the disagreement between theory and experiment. Calculations^{12,13} on

alkali halide molecules, on the other hand, indicate that the field gradient at the positive ion nucleus is substantially affected by multipole moments, particularly the dipole moment, induced in the negative ion. It is noteworthy that, in the cases cited above, the negative ions have large polarizabilities and are situated at points in the lattice where electric fields may exist and induced dipole moments may be expected. The effect of dipole polarization in nonideal wurtzite structures has recently been investigated in ZnS by photovoltage studies¹⁴ and the explanation of the coupling constant of niobium in KNbO_3 has been facilitated by invoking the dipole moments induced on neighboring oxygen ions.⁷ In ionic solids, therefore, it seems appropriate to consider the contribution to the field gradient at the nuclei from multipole moments induced in the ions before drawing conclusions about the extent of covalent binding and its effects. In spite of the diffuseness of the O^{--} charge distribution in the oxides listed above, the compactness of the positive ions, as manifested by their small radii, argues against the possibility of much covalent bonding. The question can only be settled ultimately by careful band-structure calculations.

The electrostatic effects of higher multipole moments of ions in a crystal lattice have been discussed theoretically and methods for the calculation of the crystalline potential and its derivatives in lattices of sources having arbitrary multipolar composition are in existence.¹⁵⁻¹⁸

This article considers the question of higher multipole moments and their effect upon field gradient at the ionic nuclei in beryllium oxide. This substance has a nonideal wurtzite structure with ions at the positions given in Table I. The unit cell is illustrated in Fig. 1. The lattice parameters of BeO at 21°C have recently been determined¹⁹ with high accuracy: $c=4.3772 \pm 0.0002 \text{ \AA}$, $a=2.6979 \pm 0.0001 \text{ \AA}$, and $c/a=1.62245$

* Supported in part by the U. S. National Science Foundation.

† Permanent address: Department of Physics, Loyola University of Los Angeles, Los Angeles 45, California.

¹ A. K. Saha and T. P. Das, *Nuclear Induction* (Saha Institute of Nuclear Physics, Calcutta, India, 1957), Chap. 6.² M. H. Cohen and F. Reif, in *Solid-State Physics*, edited by F. Seitz and D. Turnbull (Academic Press Inc., New York, 1957), Vol. 5.³ R. Bersohn, *J. Chem. Phys.* **29**, 326 (1958).⁴ R. A. Bernheim and H. S. Gutowsky, *J. Chem. Phys.* **32**, 1072 (1960).⁵ David H. Anderson, *J. Chem. Phys.* **35**, 1353 (1961).⁶ Gerald Burns, *Phys. Rev.* **123**, 1634 (1961).⁷ Robert R. Hewitt, *Phys. Rev.* **121**, 45 (1961).⁸ J. F. Hon, *Phys. Rev.* **124**, 1368 (1961).⁹ R. G. Barnes, S. L. Segel, and W. H. Jones, Jr., *J. Appl. Phys.* **33**, 296 (1962).¹⁰ R. V. Pound, *Phys. Rev.* **79**, 685 (1950).¹¹ O. C. Kistner and A. W. Sunyar, *Phys. Rev. Letters* **4**, 412 (1960).¹² T. P. Das and M. Karplus, *J. Chem. Phys.* **30**, 848 (1959).¹³ Gerald Burns, *Phys. Rev.* **115**, 357 (1959).¹⁴ S. G. Ellis, F. Herman, E. E. Loebner, W. J. Merz, C. W. Struck, and J. G. White, *Phys. Rev.* **109**, 1860 (1958).¹⁵ F. W. DeWette and B. R. A. Nijboer, *Physica* **24**, 1105 (1958).¹⁶ F. W. DeWette, *Physica* **25**, 1225 (1959).¹⁷ R. R. Hewitt and T. T. Taylor, *Phys. Rev.* **125**, 524 (1962).¹⁸ T. T. Taylor, *Phys. Rev.* **127**, 120 (1962).¹⁹ B. Bellamy, T. W. Baker, and D. T. Livey, *J. Nucl. Mater.* **6**, 1 (1962).

TABLE I. Crystallographic positions of ions in the hexagonal unit cell of BeO.

Ion	Abbreviated designation	Positions in unit cell
Be ⁺⁺	R	(0,0,0); ($\frac{1}{3}, \frac{2}{3}, \frac{1}{2}$)
O ⁻⁻	X	(0,0,u); ($\frac{1}{3}, \frac{2}{3}, \frac{1}{2}+u$)

± 0.00013 . The sublattice displacement parameter u is not so well known and the best value presently available²⁰ to the authors is 0.378. Whereas c and a are unequivocally defined by the periodicity of the lattice, the very meaning of u is contingent upon an adequate definition of the ionic centroid. This question arises again in connection with ionic polarizability and a working definition of the ionic centroid is given. Using this, contributions to the field gradient are calculated as functions of u and it is found that a value quite close to 0.378 yields results in agreement with experiment. It may be remarked that the field gradient produced by the monopole moments alone vanishes at $u=0.37765$, hence, it is absolutely essential to invoke the higher moments.

The numerical calculations reported here were performed on an IBM 1620 computer.

Gaussian units are used throughout this article.

II. GENERAL THEORY

Following the notation of Saha and Das,¹ the expansion of a Laplacian electrostatic potential about a point \mathbf{r}_e is characterized by the coefficients \mathcal{E}_l^m :

$$V(\mathbf{r}) = \sum_{l=0}^{\infty} \sum_{m=-l}^l \mathcal{E}_l^m |\mathbf{r}-\mathbf{r}_e|^{l+1} (4\pi/2l+1)^{1/2} Y_l^{m*}(\theta, \phi), \quad (2.1)$$

where θ and ϕ express the direction of $\mathbf{r}-\mathbf{r}_e$. Similarly, the electric multipole moments of a localized charge distribution, reckoned with respect to the point \mathbf{r}' , are denoted Q_l^m :

$$Q_l^m = \int \rho |\mathbf{r}-\mathbf{r}'|^l \left(\frac{4\pi}{2l+1} \right)^{1/2} Y_l^m(\theta, \phi) d\tau, \quad (2.2)$$

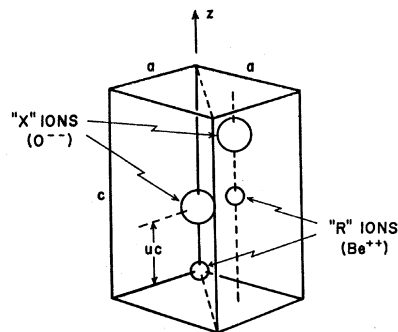

FIG. 1. Hexagonal unit cell of BeO.

where θ and ϕ now express the direction of $\mathbf{r}-\mathbf{r}'$ and ρ is the charge density. Our definition of the surface harmonics Y_l^m , given in Ref. 1, is consistent with that used by Condon and Shortley,²¹ Ramsey,²² Pound,¹⁰ and many others; the \mathcal{E}_l^m and Q_l^m symbols are, respectively, equal to the $F_q^{(k)}$ and $Q_q^{(k)}$ used by Ramsey with $k=l$ and $q=m$. The C_l^m and B_l^m of Hewitt and Taylor¹⁷ reduce to \mathcal{E}_l^m and Q_l^m only for $m=0$.

The \mathcal{E}_l^m coefficients are related to the derivatives of the potential evaluated at \mathbf{r}_e . If $\mathbf{p}=\nabla$, the operator $\mathbf{p}^l Y_l^m(\theta, \phi)$ has meaning since it is a homogeneous polynomial in $\partial/\partial x$, $\partial/\partial y$, and $\partial/\partial z$. Following the example of Cohen,²³ it is not difficult to show that

$$\mathcal{E}_l^m = [2^l (\frac{1}{2})_l]^{-1} [\mathbf{p}^l (4\pi/2l+1)^{1/2} Y_l^m(\theta, \phi) V]_{\mathbf{r}_e}, \quad (2.3)$$

where $(z)_l$ means $\Gamma(l+z)/\Gamma(z)$. Using (2.3) and letting \mathbf{E} represent the electric field at the expansion point, it is seen that

$$\mathcal{E}_1^0 = \partial V / \partial z = -E_z; \quad (2.4)$$

$$\begin{aligned} \mathcal{E}_1^{\pm 1} &= 2^{-1/2} (\mp \partial V / \partial x - i \partial V / \partial y) \\ &= 2^{-1/2} (\pm E_x + i E_y). \end{aligned} \quad (2.5)$$

Similar relationships for the \mathcal{E}_2^m coefficients may be found in Ref. 1, p. 370.

Because of the negative sign in (2.4), the authors choose to define the multipolar polarizability tensor $\alpha_{l', m', l''}^m$ of a localized charge distribution by the equation

$$Q_{l', m'} = -\alpha_{l', m', l''}^m \mathcal{E}_l^m. \quad (2.6)$$

Only axial components ($m=m'=0$) of the dipolar and quadrupolar polarizability tensors occur in the remainder of this article, hence, the less cumbersome symbols α and β are used for these two quantities, respectively. Thus,

$$Q_1^0 = -\alpha \mathcal{E}_1^0 \quad \text{or} \quad \mathcal{P}_z = \alpha E_z, \quad (2.7)$$

and

$$Q_2^0 = -\beta \mathcal{E}_2^0. \quad (2.8)$$

Attention is directed to the fact that the quantity \mathcal{E}_2^0 , which is here called the "axial field gradient" is actually one-half of the quantity conventionally designated by this term. Similarly, the quantity Q_2^0 which we label the "axial quadrupole moment" is one-half the conventional axial quadrupole moment. In spite of this disagreement with convention, the notational system employing the \mathcal{E}_l^m and Q_l^m symbols has valuable internal consistencies and the authors choose to use it in all analyses and calculations. The necessary factor of 2 is supplied at the very end when the coupling constant, $e^2 q Q / h$, is calculated.

Correlative to the polarizability of a single localized charge distribution or source, we introduce another tensor $G_{l', m', l''}^m$ which is a function of the crystal structure

²¹ E. U. Condon and G. H. Shortley, *The Theory of Atomic Spectra* (Cambridge University Press, Cambridge, 1953), p. 52.

²² Norman F. Ramsey, *Molecular Beams* (Oxford University Press, London, 1955), pp. 52-57.

²³ M. H. Cohen, *Phys. Rev.* **95**, 674 (1954).

²⁰ G. A. Jeffrey, G. S. Parry, and R. L. Mozzi, *J. Chem. Phys.* **25**, 1024 (1956).

and the location of the expansion point relative thereto. This four-index symbol is equal to the potential component \mathcal{E}_l^m generated at the expansion point per multipole moment Q_{l^m} of contributing sources situated at lattice points. Thus,

$$\mathcal{E}_l^m = G_l^{m_l, m'} Q_{l^m}. \quad (2.9)$$

In the event the expansion point coincides with a source, the effect of this source is deleted. The problem of finding the $G_l^{m_l, m'}$ symbols is the problem of *lattice summation* and is well understood. The G symbols used here were calculated by the method of Refs. 17 and 18; the actual formulas employed, translated into the present nomenclature, appear in Appendix A.

In finding the crystalline potential due to the multipole moments of the ions, consistency conditions must be satisfied since the crystalline potential itself induces all moments higher than the monopole. In the subsequent analysis, we consider moments only as high as $l'=2$.

$$\begin{pmatrix} G_{1R1R} + \alpha_R^{-1} & G_{1R1X} & G_{1R2R} & G_{1R2X} \\ G_{1X1R} & G_{1X1X} + \alpha_X^{-1} & G_{1X2R} & G_{1X2X} \\ G_{2R1R} & G_{2R1X} & G_{2R2R} + \beta_R^{-1} & G_{2R2X} \\ G_{2X1R} & G_{2X1X} & G_{2X2R} & G_{2X2X} + \beta_X^{-1} \end{pmatrix} \begin{pmatrix} Q_{1R} \\ Q_{1X} \\ Q_{2R} \\ Q_{2X} \end{pmatrix} = \begin{pmatrix} -G_{1R0R}Q_{0R} - G_{1R0X}Q_{0X} \\ -G_{1X0R}Q_{0R} - G_{1X0X}Q_{0X} \\ -G_{2R0R}Q_{0R} - G_{2R0X}Q_{0X} \\ -G_{2X0R}Q_{0R} - G_{2X0X}Q_{0X} \end{pmatrix}. \quad (2.10)$$

In BeO, the R ions constitute an hexagonal close-packed system with nonideal c/a ratio. The X ions constitute an identical system which interpenetrates the R system but is displaced from the latter by a distance uc in the z direction. From the identical character of the two systems, we conclude that

$$G_{lRlR} = G_{lXlX}. \quad (2.11)$$

It also follows that the total structure viewed from an R site with the observer looking in the $+z$ direction will appear the same as if viewed from an X site with the observer looking in the $-z$ direction, except that R and X ions will be interchanged in the two cases. Thus interchanging R and X is equivalent to changing the sign of the z coordinate, and

$$G_{lRlX} = (-1)^{l+l'} G_{lXlR}. \quad (2.12)$$

An obvious corollary is

$$G_{lRlR} = G_{lXlX} = 0 \quad \text{for } l+l' \text{ odd}. \quad (2.13)$$

This relationship immediately reduces six of the G

As indicated earlier, $m'=0$ for all of these since both R and X ions are situated on a threefold axis of symmetry. For simplicity, the m' superscript is omitted entirely; Q_{0R} , Q_{1R} , and Q_{2R} , respectively, represent the monopole, axial dipole, and axial quadrupole moments of the Be^{++} ion and α_R and β_R represent its dipolar and quadrupolar polarizabilities. The same notations with X substituted for R apply to the O^{--} ion. The G symbols are also simplified by omitting superscripts; R and X identifications are added, however. Thus G_{lRlX} means the \mathcal{E}_l^0 potential component generated at the site of a type R ion per Q_{l^0} moment of all type X ions.

The consistency conditions form a set of simultaneous linear equations with Q_{1R} , Q_{1X} , Q_{2R} , and Q_{2X} as the unknowns and Q_{0R} and Q_{0X} as knowns. The fields and field gradients established by the monopole moments are the driving forces of the system and are put on the right-hand side. The equations may be written as follows:

symbols in (2.10) to zero. Application of (2.11) and (2.12) reduces the remaining number of apparently independent G symbols from eighteen to nine, namely, G_{1X1X} , G_{2X2X} , G_{1X1R} , G_{1X2R} , G_{2X1R} , G_{2X2R} , G_{1X0R} , G_{2X0R} , and G_{2X0X} .

We now invoke some equivalences for axial lattice sums listed in Appendix A. Using these, it is found that

$$G_{1X2R} = -G_{2X1R}. \quad (2.14)$$

$$G_{2X0R} = -\frac{1}{2}(G_{1X1R} + \frac{1}{3}8\pi\tau_0); \quad (2.15)$$

$$G_{2X0X} = -\frac{1}{2}(G_{1X1X} + \frac{1}{3}8\pi\tau_0), \quad (2.16)$$

where $\tau_0 = \frac{1}{2}3^{1/2}a^2c$, the volume of the unit cell. These three relationships further reduce the number of independent G symbols from nine to six. Values of the G symbols relevant to the present article are given in Tables II and III.

III. IONIC POLARIZABILITY

With regard to dipolar polarizability, the simple model of Fig. 2 is adopted. The ion is assumed to con-

TABLE II. Calculated values of the u -independent G symbols for the BeO structure with $c/a = 1.62245$. Symbol τ_0 indicates volume of unit cell.

Quantity	Value
$a^3 G_{1X1X} = a^3 G_{1R1R}$	-6.01575
$a^5 G_{2X2X} = a^5 G_{2R2R}$	5.06433
$a^3 G_{2X0X} = a^3 G_{2R0R}$	0.0267064
$a^3 \frac{1}{3}8\pi\tau_0$	5.96234

FIG. 2. Simple model of ion showing core bound to sheath centroid. Restoring mechanism symbolized by spring with elastic constant K_0 .

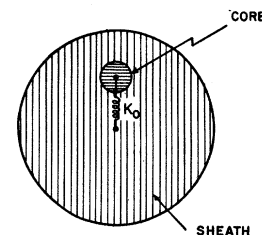

TABLE III. Calculated values of the u -dependent G symbols for the BeO structure with $c/a=1.62245$ and four assumed values of u .

Quantity	Value			
u	0.3765	0.3770	0.3775	0.3780
$a^2G_{1X0R} = -a^2G_{1R0X}$	0.0190600	0.0240425	0.0289680	0.0338368
$a^3G_{1X1R} = a^3G_{1R1X}$	-6.17707	-6.10678	-6.03668	-5.96679
$a^4G_{2X1R} = -a^4G_{2R1X}$				
$= a^4G_{1R2X} = -a^4G_{1X2R}$	43.3918	43.2662	43.1406	43.0149
$a^3G_{2X0R} = a^3G_{2R0X}$	0.107367	0.072218	0.037170	0.002224
$a^5G_{2X2R} = a^5G_{2R2X}$	77.3760	77.4051	77.4400	77.4807

sist of a core having charge eZ_c , in which most of the mass resides, and a sheath with charge $-eZ_s$. In the present article, the core is considered to be the nucleus; the sheath, the entire electronic configuration. Other allocations of charge between core and sheath are conceivable and the implications of this are discussed below. It is assumed that the distortion of the polarized ion may be regarded simply as a relative displacement between the charge centroid of the core and that of the sheath against quantum mechanical restoring forces symbolized by the spring of elastic constant K_0 . We may immediately write the dipolar polarizability of the free ion at optical frequency (where the heavy core undergoes negligible displacement) as

$$\alpha' = K_0^{-1}e^2Z_s^2. \quad (3.1)$$

This result and others are summarized in Table IV.

Calculations by Pauling,²⁴ by Wikner and Das,²⁵ and by Sternheimer²⁶ agree that the free-ion dipolar polarizability of Be^{++} is about 0.008 \AA^3 . For the O^{--} ion, on the other hand, Pauling obtains 3.88 \AA^3 . In view of these figures and similar ones for the quadrupolar polarizabilities, the external effects of all moments of the Be^{++} ions higher than the monopole are neglected in the final calculations in this article.

An O^{--} ion bound in BeO is illustrated symbolically in Fig. 3. Here it is assumed that the bonding, which again is quantum mechanical, may be regarded as acting on the sheath centroid and may be symbolized

TABLE IV. Axial dipolar polarizabilities of an ion with core charge eZ_c and sheath charge $-eZ_s$ under various conditions. K_0 and K are elastic constants defined in text.

Formula	Description
$\alpha' = K_0^{-1}e^2Z_s^2$	Dipolar polarizability at optical frequency for free ion.
$\alpha'' = (K_0 + K)^{-1}e^2Z_s^2$	Dipolar polarizability at optical frequency for ion bound in crystal lattice.
$\alpha = K_0^{-1}e^2Z_c^2$	Apparent dipolar polarizability of ion in permanent local crystalline field.
$\tilde{\alpha} = e^2[K_0^{-1}Z_c^2 + K^{-1}(Z_c - Z_s)^2]$	Incremental dipolar polarizability of ion with respect to additional local static field.

²⁴ L. Pauling, Proc. Roy. Soc. (London) **A114**, 191 (1927).

²⁵ E. G. Wikner and T. P. Das, Phys. Rev. **107**, 497 (1957).

²⁶ R. M. Sternheimer, Phys. Rev. **107**, 1565 (1957).

by four springs connected to adjacent Be^{++} ions. Static electric field due to sources within the crystal is present at the O^{--} ion sites, hence, the bonding system is permanently stressed and the O^{--} sheath centroid occupies an equilibrium position z' with respect to the Be^{++} ion immediately below it in the arrangement of Fig. 3. This position z' is regarded as *the* position of the O^{--} ion and the reference with respect to which its moments are to be calculated. In view of the permanent field, the spring K_0 is also stressed and the O^{--} ion has a permanent dipole moment with respect to the point at z' because of the displacement of its core. The ratio of this moment to the permanent crystalline field is called the apparent polarizability, α . Thus,

$$\alpha = K_0^{-1}e^2Z_c^2. \quad (3.2)$$

The principal objective of this section is to obtain the apparent polarizability for the O^{--} ion. One might think this task trivial since K_0 can be eliminated between (3.1) and (3.2) yielding

$$\alpha = \alpha' Z_c^2 / Z_s^2. \quad (3.3)$$

Actually, α can also be obtained from the quantities α'' and $\tilde{\alpha}$ of Table IV. The latter method is preferable for two reasons: (1) both α'' and $\tilde{\alpha}$ have been measured experimentally, whereas we must rely upon a calculated value for α' ; and (2) when α is obtained from α'' and $\tilde{\alpha}$, the result is found to be very insensitive to the allocation of charge between ion core and sheath, whereas when α is obtained from α' the result is quite sensitive to this allocation as is obvious from (3.3). We now discuss α'' and $\tilde{\alpha}$ and the method of obtaining α from them.

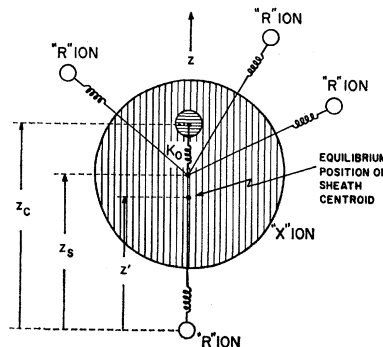

FIG. 3. An O^{--} or type X ion bound in the BeO lattice. Sheath centroid is shown displaced from equilibrium position for clarity.

With the O^{--} ion sheath centroid in its equilibrium position at z' , an additional local field at optical frequency may be impressed. The heavy core will not respond to this field, but the sheath will attempt to follow the field against the combined action of the restoring forces associated with the bond to the core and with the external bonding. If the elastic constant in the z direction of the external bonding is K , one has for the optical polarizability of the bound ion

$$\alpha'' = (K_0 + K)^{-1} e^2 Z_s^2. \quad (3.4)$$

Finally, an additional local static or quasistatic field may be applied at the O^{--} sites by plating electrodes on a single crystal and applying a potential difference. The result desired is that obtained with c/a held constant, that is, under conditions of constant strain. Experimental work in this area is usually done under conditions of constant stress, but a theory exists²⁷ whereby the former results can be inferred from the latter. (The distinction is actually inconsequential in BeO, which is only very weakly piezoelectric.) Calling the additional local field E_{za} , it is seen that the sheath centroid of the O^{--} ion will migrate to a new position z_s such that

$$z_s - z' = K^{-1} e (Z_c - Z_s) E_{za}. \quad (3.5)$$

At the same time, the O^{--} core migrates to a new position z_c , where

$$z_c - z_s = K_0^{-1} e Z_c (E_{zc} + E_{za}), \quad (3.6)$$

and E_{zc} is the permanent crystalline field. Adding these results, one obtains

$$z_c - z' = K_0^{-1} e Z_c (E_{zc} + E_{za}) + K^{-1} e (Z_c - Z_s) E_{za}. \quad (3.7)$$

The total dipole moment is given by

$$p_z = e Z_c (z_c - z') - e Z_s (z_s - z'); \quad (3.8)$$

$$p_z = e^2 [K_0^{-1} Z_c^2 (E_{zc} + E_{za}) + K^{-1} Z_c (Z_c - Z_s) E_{za} - K^{-1} Z_s (Z_c - Z_s) E_{za}]. \quad (3.9)$$

The incremental polarizability $\tilde{\alpha}$ is the derivative $\partial p_z / \partial E_{za}$. Thus,

$$\tilde{\alpha} = e^2 [K_0^{-1} Z_c^2 + K^{-1} (Z_c - Z_s)^2]. \quad (3.10)$$

The two elastic constants K_0 and K may be eliminated among Eqs. (3.2), (3.4), and (3.10) to yield a quadratic equation in α . Of the two solutions of this equation, the one with physical meaning is

$$\alpha = \frac{1}{2} \{ \tilde{\alpha} + \xi \alpha'' + [\tilde{\alpha}^2 - \tilde{\alpha} \alpha'' (1 + \xi^2) + \alpha''^2 \xi^2]^{1/2} \}, \quad (3.11)$$

where $\xi = (2Z_c/Z_s) - 1$.

We now proceed to obtain values of α'' and $\tilde{\alpha}$ from experimental dielectric constants. Clausius-Mossotti theory is adequate at the level of accuracy attempted here; it is, however, possible to construct a more

sophisticated theory using the lattice sums of the previous section. Tessman, Kahn, and Shockley²⁸ give $\alpha'' = 1.29 \text{ \AA}^3$ directly for O^{--} in BeO. Austerman, Berlincourt, and Krueger²⁹ report $7.66 \pm 4\%$ for the 33 component of the dielectric tensor at constant stress in BeO single crystal; other data in the same article indicate that the value at constant strain is negligibly different from this. We find, then, that $\tilde{\alpha} = 2.27 \text{ \AA}^3 \pm 1.4\%$.

When these values of α'' and $\tilde{\alpha}$ are substituted into (3.11) with $Z_c = 8$ and $Z_s = 10$, the result is

$$\alpha = \alpha_X = 2.19 \text{ \AA}^3. \quad (3.12)$$

If one chooses to regard the oxygen nucleus and the $1s^2$ configuration together as the core with the $2s^2 2p^6$ configuration as the sheath, then $Z_c = 6$, $Z_s = 8$, and α_X becomes equal to 2.15 \AA^3 . The small difference between this and the previous value is reassuring, as is the precision of the value of $\tilde{\alpha}$ upon which α_X principally depends. We regard $Z_c = 8$ as more realistic than $Z_c = 6$ and therefore adopt 2.19 \AA^3 as the more probable value. Considering the uncertainty of some of the other quantities with which we are concerned here, the dipolar polarizability of the O^{--} ion is remarkably well established.

A value for the quadrupolar polarizability of O^{--} is obtained from a theoretical paper by Burns and Wikner.³⁰ We use

$$\beta_X = 7.0 \text{ \AA}^3, \quad (3.13)$$

which is an average of two results given by these authors. The precision of this result is probably considerably less than that associated with the dipolar polarizability.

IV. RESULTS AND CONCLUSIONS

As indicated earlier, the higher moments of the Be^{++} ion are to be neglected in solving Eq. (2.10); we therefore set Q_{1R} and Q_{2R} equal to zero and these equations become

$$\begin{bmatrix} G_{1X1X} + \alpha_X^{-1} & 0 \\ 0 & G_{2X2X} + \beta_X^{-1} \end{bmatrix} \begin{bmatrix} Q_{1X} \\ Q_{2X} \end{bmatrix} = \begin{bmatrix} -G_{1X0R} Q_{0R} \\ -G_{2X0R} Q_{0R} - G_{2X0X} Q_{0X} \end{bmatrix}. \quad (4.1)$$

The solution of the above is very simple and Q_{1X} is independent of any assumptions regarding β_X ; Q_{2X} , of α_X . Values calculated from (4.1) are given in Table V.

The total field gradient at the Be^{++} ion \mathcal{E}_{2R} is

²⁸ Jack R. Tessman, A. H. Kahn, and William Shockley, Phys. Rev. **92**, 890 (1953).

²⁹ S. B. Austerman, D. A. Berlincourt, and H. H. A. Krueger, J. Appl. Phys. **34**, 339 (1963).

³⁰ Gerald Burns and E. G. Wikner, Phys. Rev. **121**, 155 (1961).

²⁷ IRE Standards on Piezoelectric Crystals, 1957, Proc. IRE **46**, 764 (1958).

TABLE V. Calculated results for four assumed values of u : higher moments of the O^{--} ion, field gradients at Be^{++} and O^{--} ion sites, and coupling constants. Lattice parameter $a=2.6979 \text{ \AA}$; e is charge of proton.

Quantity	Value				
u	0.3765	0.3770	0.3775	0.3780	
Q_{1X}/ea	-0.01292	-0.01629	-0.01963	-0.02293	
Q_{2X}/ea^2	-0.006330	-0.003572	-0.000821	0.001921	
$a^3 \mathcal{E}_{2R}$	due to all monopoles	-0.1613	-0.0910	-0.0209	0.0490
	due to O^{--} dipoles	0.5605	0.7050	0.8470	0.9865
e	due to O^{--} quadrupoles	-0.4898	-0.2765	-0.0636	0.1489
	total	-0.0906	0.3375	0.7625	1.1844
	Be ⁹ coupling constant	-13 kc/sec	49 kc/sec	110 kc/sec	170 kc/sec
$a^3 \mathcal{E}_{2X}$	due to all monopoles	0.1613	0.0910	0.0209	-0.0490
	due to O^{--} quadrupoles	-0.0321	-0.0181	-0.0042	0.0097
e	total	0.1292	0.0729	0.0167	-0.0393
	O^{17} coupling constant	-355 kc/sec	-200 kc/sec	-46 kc/sec	108 kc/sec

calculated in the following way:

$$\mathcal{E}_{2R} = G_{2R0R}Q_{0R} + G_{2R0X}Q_{0X} + G_{2R1X}Q_{1X} + G_{2R2X}Q_{2X}. \quad (4.2)$$

The dimensionless quantity $a^3 \mathcal{E}_{2R}/e$ and the terms which compose it are given in Table V and are plotted with respect to u in Fig. 4. The coupling constant is related to \mathcal{E}_{2R} as follows:

$$e^2 q Q / h = (eQ/h)(1 - \gamma_\infty) 2 \mathcal{E}_{2R}. \quad (4.3)$$

Here $(1 - \gamma_\infty)$ is the antishielding factor introduced by Sternheimer³¹⁻³³ who gives 0.811 for $(1 - \gamma_\infty)$ of the Be^{++}

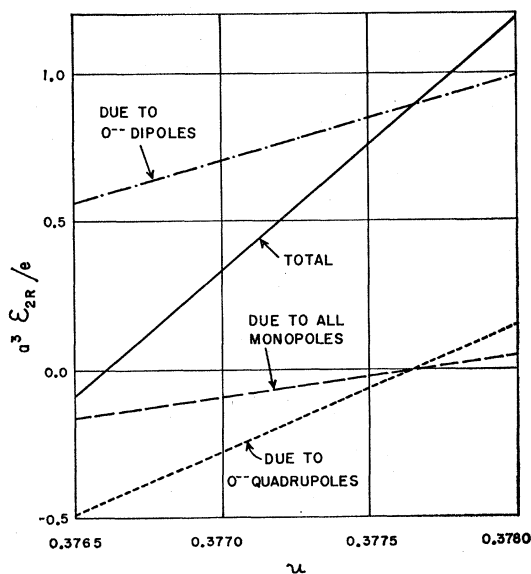

FIG. 4. Electric field gradient at Be^{++} or type R ion site in BeO .

³¹ R. M. Sternheimer, Phys. Rev. **84**, 244 (1951).

³² H. M. Foley, R. M. Sternheimer, and D. Tycko, Phys. Rev. **93**, 734 (1954).

³³ R. M. Sternheimer and H. M. Foley, Phys. Rev. **102**, 731 (1956).

ion.³⁴ Lurio³⁵ has made a tentative determination of $+0.05$ b for Q of the Be^9 nucleus. Using these values, the coupling constant for Be^9 has been calculated and is listed as a function of u in Table V. Hon's experimental value⁸ of $\pm 41 \pm 4$ kc/sec agrees with the present calculations for u slightly less than 0.377. Considering the x-ray value of 0.378 obtained by Jeffrey, Parry, and Mozzi,²⁰ there is reasonable agreement between theory and experiment. Further refinement cannot be expected until more precise values of Q , u , and the quadrupolar polarizability of O^{--} become available.

The rapid variation of the field gradient with respect to u is a singular feature of this problem and it is conceivable that, at some future time, nuclear resonance measurements will be considered more effective than x-ray diffraction for the final and precise determination of certain crystal structure parameters. The same conclusion could be drawn from the work of Brun and Hafner³⁶ who made an analogous calculation on Al_2O_3 using a summation in the real lattice over a relatively limited number (about 2500) of ions.³⁷

If the nuclear magnetic resonance of the spin- $\frac{5}{2}$ nucleus O^{17} could be studied in BeO , possibly using an enriched sample, more information relevant to the present problem could be obtained. Because of the vanishing of G_{2X1X} and of the relatively negligible part played by the higher moments of the Be^{++} ion, the field gradient at an O^{--} site depends only upon the monopole contribution and upon the effect of the

³⁴ R. M. Sternheimer, Phys. Rev. **115**, 1198 (1959).

³⁵ Allen Lurio (private communication).

³⁶ E. Brun and S. Hafner, Z. Krist. **117**, 63 (1962).

³⁷ R. R. Sharma and T. P. Das have in progress an extensive program for investigating the crystalline fields in Al_2O_3 , Cr_2O_3 , and Fe_2O_3 to interpret the available experimental data in much the same manner as the present article. Their summations extend over much larger numbers of ions (about 10^6) than Brun and Hafner considered, and they make use of the very recent crystal structure data of R. E. Newnham and Y. M. De Haan, Z. Krist. **117**, 235 (1962) and of G. Shirane, D. E. Cox, W. J. Takei, and S. L. Ruby, J. Phys. Soc. Japan **17**, 1598 (1962).

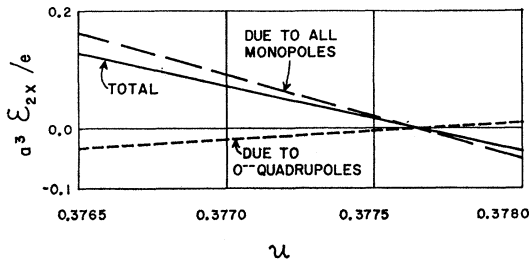

FIG. 5. Electric field gradient at O^{2-} or type X ion site in BeO.

quadrupole moments induced in the O^{2-} ions. Thus,

$$\mathcal{E}_{2X} = G_{2X0R}Q_{0R} + G_{2X0X}Q_{0X} + G_{2X2X}Q_{2X}. \quad (4.4)$$

Again the dimensionless quantity $a^3 \mathcal{E}_{2X}/e$ is presented in Table V and Fig. 5. Burns and Wikner³⁰ give 29.22 for $(1-\gamma_\infty)$ of the O^{2-} ion and Kamper, Lea, and Lustig³⁸ obtain -0.0265 b for Q of the O^{17} nucleus. On the basis of these values, the coupling constant of O^{17} was calculated and is also given in Table V. An experimental determination of this quantity would be very interesting³⁹ since it would shed light on the quadrupole polarizability of O^{2-} without invoking the dipolar polarizability of this ion.

ACKNOWLEDGMENTS

The authors are happy to acknowledge private communications from Allen Lurio of the IBM Watson Laboratory relevant to the nuclear quadrupole moment of Be⁹ and from D. A. Berlincourt of the Clevite Corporation on the relationship between dielectric tensors at constant stress and at constant strain in BeO.

APPENDIX A: CALCULATION OF G SYMBOLS

It is not difficult to rederive the lattice sum method reported by Hewitt and Taylor¹⁷ in terms of the notation of this article and to arrive at an expression for \mathcal{E}_l^m at a given expansion point due to a lattice of multipolar sources, each having moment $Q_{l'm'}$. Dividing the former by $Q_{l'm'}$, one obtains an expression for G_l^m :

$$G_l^m = \begin{cases} -\delta_{l0} \delta_{m0} (l + \frac{3}{2}) n r_1^{-(2l+1)} / n! \\ 0 \end{cases} \\ -\delta_{0l} \delta_{0l} \pi N q r_1^2 / (\frac{3}{2} + n) \\ + \frac{4\pi i^l}{2^l (\frac{3}{2})_l} \sum_{\mathbf{h}} \frac{A(\mathbf{h})}{Q_{l'm'}} (2\pi \mathbf{h})^{l-2} \Lambda_{n+l+\frac{3}{2}}(2\pi \mathbf{h} r_1) \\ \times (4\pi/2l+1)^{1/2} Y_l^m(\theta_{\mathbf{h}}, \phi_{\mathbf{h}}). \quad (A1)$$

³⁸ R. A. Kamper, K. R. Lea, and C. D. Lustig, Proc. Phys. Soc. (London) **B70**, 897 (1957).

³⁹ We are indebted to one of the referees for suggesting the possibility of detecting the sign of the coupling constant by incrementing the natural field gradient through the external application of an electric field or a mechanical stress.

Here the upper value in the braces is to be used if a source is actually present at the expansion point, otherwise the lower value (zero) is to be used. This change, which is appreciable, arises because the effect of a source *at* the expansion point is deleted, but the effect of a source only slightly removed from the expansion point is included and is powerful. N_q is the number of monopoles per unit cell and comes into play only if G_0^0 is being calculated. The distance parameter r_1 must be chosen so that a sphere of this radius contains all charge belonging to the source at the origin (if there is one) and no charge belonging to any other source. The quantity n is an arbitrary non-negative integer and the function $\Lambda_\nu(z) = \Gamma(1+\nu)(2/z)^\nu J_\nu(z)$.

The Fourier coefficient $A(\mathbf{h})$ was derived¹⁸ using a model in which the charge density of each source resides on a spherical shell of radius s_1 . Introducing present notation, the expression for $A(\mathbf{h})/Q_{l'm'}$ for a unit cell containing N sources at positions \mathbf{r}_k' and for $\mathbf{h} \neq 0$ becomes:

$$\frac{A(\mathbf{h})}{Q_{l'm'}} = \tau_0^{-1} \left[\sum_{k=1}^N \exp(-2\pi i \mathbf{h} \cdot \mathbf{r}_k') \right] \frac{(-2\pi i \mathbf{h})^{l'}}{2^{l'} (\frac{3}{2})_{l'}} \\ \times \Lambda_{l'+\frac{3}{2}}(2\pi h s_1) (4\pi/2l'+1)^{1/2} Y_{l'm'}(\theta_{\mathbf{h}}, \phi_{\mathbf{h}}). \quad (A2)$$

The quantity in square brackets is the structure factor for the N sources. The values of s_1 and r_1 are interdependent since in no case may r_1 be greater than $r_0 - s_1$, where r_0 is the distance from the expansion point to the center of the nearest source. In most cases it is convenient to let $s_1 \rightarrow 0$, whereupon the Λ function in (A2) may simply be set equal to unity. It must be remembered that $A(0) = 0$ even for $l' = 0$ because of the compensating background charge density which must be present in this case.

If $l' = 0$, which means that the sources are monopoles, the Fourier coefficients simplify very considerably. This may be exploited by invoking the equivalence relations developed in Ref. 18 whereby all G symbols with $m = m' = 0$ and $l + l' = L$, a constant, are related. Thus, if $L \geq 3$, one has

$$G_l^0 = (-1)^l \binom{L}{l} G_L^0, \quad (A3)$$

where

$$\binom{L}{l}$$

is a binomial coefficient. When $L = 2$, a Lorentz term involving N_d , the number of dipoles per unit cell, must be included and

$$G_l^0 + \delta_{l2} \frac{4\pi N_d}{3\tau_0} = (-1)^l \binom{L}{l} G_L^0. \quad (A4)$$