

# Dynamical Approach to the Unitary-Symmetry Mass Formula Based on $\omega$ - $\varphi$ Mixing\*

J. J. SAKURAI†

*The Enrico Fermi Institute for Nuclear Studies and Department of Physics,  
The University of Chicago, Chicago, Illinois*

(Received 10 May 1963)

Possible dynamical mechanisms that give rise to the unitary-symmetry mass formula of Gell-Mann and Okubo are discussed with special emphasis on a model based on  $\omega$ - $\varphi$  mixing. In addition to accounting for the mass formula in a rather natural manner, the  $\omega$ - $\varphi$  mixing model has the following distinctive features: (1) It explains why the mass formula fails for the vector meson octet. (2) It requires  $m_p < m_M$  provided  $m_\pi < m_K$ . (3) It leads to  $|m_\Xi - m_N| \gg |m_\Sigma - m_\Lambda|$ , provided the couplings of the vector mesons to the baryons are predominantly of the  $F$  type (as expected from the point of view of the conserved-vector-current theory). (4) It justifies the conjecture that it is more proper to use, in the mass formula,  $(\text{mass})^2$  for the mesons, but just the mass for the baryons. (5) The corrections to the mass formula are expected to be of the order of a few percent if the major contribution to the self-energies of the strongly interacting states comes from the region of a few BeV. A quantitative estimate of the  $\omega$ - $\varphi$  mixing is made, and it is shown that the observed 1020-MeV  $\varphi$  meson (the observed 780-MeV  $\omega$  meson) is about a 60-40 mixture (a 40-60 mixture) in intensity of the  $T=0$  member of a unitary octet and a unitary singlet. We also show that a pair of mass formulas of the Gell-Mann-Okubo type are "self-consistent" provided the cutoff momentum (in the perturbation-theoretic sense) is much greater than a typical difference within a unitary multiplet.

## I.

AMONG the various schemes of strong-interaction symmetry proposed in the past several years, the most promising and attractive scheme appears to be the "eightfold way" (the octet version of unitary symmetry) of Gell-Mann<sup>1</sup> and Ne'eman.<sup>2</sup> From the theoretical point of view, this model is the simplest model of higher symmetry that can accommodate vector mesons which are coupled to conserved and quasiconserved currents of strong interactions.<sup>3-6</sup> From the experimental point of view, the various strongly interacting states are beginning to fit into multiplet patterns characteristic of the model.<sup>7</sup>

There is, however, little doubt that the real charm of the eightfold way lies in the success of the unitary-symmetry mass formula,<sup>8</sup> first derived by Gell-Mann<sup>1</sup> for a unitary octet and, subsequently, generalized by Okubo<sup>9</sup> to any unitary multiplet. It is now well-known that the relations

$$\frac{1}{2}(m_\Sigma + m_\Xi) = \frac{1}{4}(3m_\Lambda + m_\Sigma), \quad (1)$$

$$\mathfrak{B} = \begin{pmatrix} (\Sigma^0/\sqrt{2}) + (\Lambda/\sqrt{6}) & \Sigma^+ & \bar{p} \\ \Sigma^- & (-\Sigma^0/\sqrt{2}) + (\Lambda/\sqrt{6}) & n \\ \Xi^- & \Xi^0 & -(2/\sqrt{6})\Lambda \end{pmatrix},$$

$$\bar{\mathfrak{B}} = \begin{pmatrix} (\bar{\Sigma}^0/\sqrt{2}) + (\bar{\Lambda}/\sqrt{6}) & \bar{\Sigma}^- & \bar{\Xi}^- \\ \bar{\Sigma}^+ & (-\bar{\Sigma}^0/\sqrt{2}) + (\bar{\Lambda}/\sqrt{6}) & \bar{\Xi}^0 \\ \bar{p} & \bar{n} & -(2/\sqrt{6})\bar{\Lambda} \end{pmatrix}, \quad (6)$$

\* This work supported by the U. S. Atomic Energy Commission.

† Alfred P. Sloan Foundation Fellow.

<sup>1</sup> M. Gell-Mann, *Phys. Rev.* **125**, 1067 (1962). (See especially Sec. VIII); California Institute of Technology Synchrotron Laboratory Report, CTSL-20, 1961 (unpublished).

<sup>2</sup> Y. Ne'eman, *Nucl. Phys.* **26**, 222 (1961).

<sup>3</sup> C. N. Yang and R. L. Mills, *Phys. Rev.* **96**, 191 (1954).

<sup>4</sup> J. J. Sakurai, *Ann. Phys. (N. Y.)* **11**, 1 (1960).

<sup>5</sup> A. Salam and J. C. Ward, *Nuovo Cimento* **20**, 419 (1961).

<sup>6</sup> M. Gell-Mann and S. L. Glashow, *Ann. Phys. (N. Y.)* **15**, 437 (1961).

<sup>7</sup> See, for example, S. L. Glashow and A. H. Rosenfeld, *Phys. Rev. Letters* **10**, 192 (1963).

<sup>8</sup> See, however, S. A. Goudsmit, *Phys. Rev. Letters* **10**, 149 (1963).

<sup>9</sup> S. Okubo, *Progr. Theoret. Phys. (Kyoto)* **27**, 949 (1962).

<sup>10</sup> For the  $J = \frac{3}{2}^+$  decuplet see also S. L. Glashow and J. J. Sakurai, *Nuovo Cimento* **25**, 337 (1962); **26**, 622 (1962); M. Gell-Mann, in *Proceedings of the 1962 International Conference on High-Energy Physics at CERN* (CERN Scientific Information Service, Geneva, 1962), p. 805.

and

$$\lambda_8 = \frac{1}{\sqrt{3}} \begin{pmatrix} 1 & 0 & 0 \\ 0 & 1 & 0 \\ 0 & 0 & -2 \end{pmatrix}. \quad (7)$$

Note that it is the absence of a term of the type

$$\text{Tr}(\bar{\mathfrak{B}}\lambda_8\mathfrak{B}\lambda_8)$$

$$\mathcal{P} = \begin{pmatrix} (\pi^0/\sqrt{2}) + (\eta/\sqrt{6}) & \pi^+ & K^+ \\ \pi^- & (-\pi^0/\sqrt{2}) + (\eta/\sqrt{6}) & K^0 \\ K^- & \bar{K}^0 & -(2/\sqrt{6})\eta \end{pmatrix}. \quad (9)$$

Because of charge conjugation invariance which requires that  $K$  and  $\bar{K}$  (but not  $N$  and  $\bar{N}$ ) be degenerate, Eq. (8) contains one less parameter than Eq. (5).

Before we consider various (fictitious and realistic) models that lead to (5) and (8), let us first observe that the success of the mass formula would be much *less* surprising in the symmetric Sakata model<sup>11</sup> than in the octet version of unitary symmetry. In the Sakata model, the most natural cause for the breakdown of unitary symmetry is the mass difference between  $N(=p, n)$  and  $\Lambda$ , analogous to (and as mysterious as or no more mysterious than) the  $\mu$ - $e$  mass difference.<sup>12</sup> If we start with a symmetry-breaking term in the Lagrangian of the form

$$-\frac{1}{3}(m_\Lambda - m_N)(\bar{p}p + \bar{n}n - 2\bar{\Lambda}\Lambda) = -[(m_\Lambda - m_N)/\sqrt{3}]\bar{b}\lambda_8 b, \quad (10)$$

where

$$b = \begin{pmatrix} p \\ n \\ \Lambda \end{pmatrix}, \quad \bar{b} = (\bar{p}, \bar{n}, \bar{\Lambda}),$$

then bound states constructed out of fundamental Sakata particles and anti-Sakata particles, such as the pseudoscalar mesons, are expected to satisfy the Gell-Mann-Okubo mass formula, provided the forces responsible for binding the Sakata particles and the anti-Sakata particles are unitary symmetric. (We may conceive of an analogous situation in nuclear physics; if the binding energies of the nucleons in nuclei were independent of electric charge so that the only isospin violating effects were due to the  $n$ - $p$  mass difference, then the members of a nuclear isospin multiplet would satisfy a simple mass formula linear in the third component of isospin  $T_3$ .) Even in the octet version of unitary symmetry, it is possible to give an entirely analogous "derivation" of the mass formula (1) by regarding the baryon octet as the bound state of two

that enables us to express the four baryon masses in terms of the three parameters  $m_0$ ,  $m_1$ , and  $m_2$  leading to the nontrivial relation (1). Similarly, the mass formula for the pseudoscalar mesons (2) is completely equivalent to the statement that the sum of the mass terms in the effective Lagrangians for the pseudoscalar mesons is given by

$$-L_m = \mu_0^2 \text{Tr}(\mathcal{P}\mathcal{P}) + \mu_1^2 \text{Tr}(\mathcal{P}\lambda_8\mathcal{P}), \quad (8)$$

where

fictitious unitary triplets, one transforming like the representation  $\mathbf{3}$ , say  $(D^+, D^0, S^0)$  with baryon number one and  $m_D \neq m_S$ , and the other transforming like the representation  $\mathbf{3}^*$ , say  $(\delta^-, \bar{\delta}^0, \bar{\sigma}^0)$  with baryon number zero and  $m_\delta \neq m_\sigma$ .<sup>13</sup> Such a "derivation," however, does not seem realistic since, in the octet version of unitary symmetry, the primitive unitary triplets themselves do not correspond to physically realizable states.

An alternative approach to the unitary-symmetry mass formula has been advocated by Okubo<sup>9</sup> who starts by postulating the existence of a symmetry-breaking Hamiltonian  $H_A$  that transforms like the  $T=0$  member of a unitary octet. The mass formula then follows to first order in  $H_A$ , but to all orders in unitary-symmetric Hamiltonians  $H_S$ .

As an example of a symmetry-breaking interaction that satisfies the Okubo criteria, let us consider a model in which the  $\eta$  meson is a "schizon" in the sense of  $SU(3)$  [just as the photon is a "schizon" in the sense of  $SU(2)$ ]. The usual unitary-symmetric interaction between the pseudoscalar octet and the baryon octet can be written as

$$L_S = g_1 \text{Tr}(\bar{\mathfrak{B}}i\gamma_5\mathcal{P}\mathfrak{B}) + g_2 \text{Tr}(\bar{\mathfrak{B}}i\gamma_5\mathfrak{B}\mathcal{P}). \quad (11)$$

Let us add to (11) another interaction,

$$L_A = g'\eta \text{Tr}(\bar{\mathfrak{B}}i\gamma_5\mathfrak{B}). \quad (12)$$

In (11) the  $\eta$  meson appears as the  $T=0$  member of the pseudo-scalar octet, whereas in (12) it appears as a unitary singlet; or, alternatively, if we always regard the  $\eta$  as the  $T=0$  member of the pseudoscalar octet, then (11) transforms like a unitary singlet, while (12) transforms like the  $T=0$  member of a unitary octet. By considering baryon self-energy diagrams, it is easy to see that the combined effect of (11) and (12) would lead to the Gell-Mann mass formula (1) to first order in  $g'$ , but to all orders in  $g_1$  and  $g_2$  provided the eight baryons are degenerate to start with.

We may parenthetically remark that we would not,

<sup>11</sup> M. Ikeda, S. Ogawa, and Y. Ohnuki, *Progr. Theoret. Phys. (Kyoto)* **22**, 715 (1959); Y. Yamaguchi, *Suppl. Progr. Theoret. Phys. (Kyoto)*, **11**, 1 (1959); J. Wess, *Nuovo Cimento* **15**, 52 (1960).

<sup>12</sup> A. Gamba, R. E. Marshak, and S. Okubo, *Proc. Natl. Acad. Sci. U. S. A.* **45**, 881 (1959).

<sup>13</sup> J. J. Sakurai, in *Proceedings of the 1962 International Summer School of Physics "Enrico Fermi,"* Varenna, Lake Como (to be published).

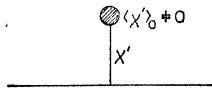

FIG. 1. Tadpole diagram that may give rise to the unitary-symmetry mass formula.

in general, obtain a mass formula of the Gell-Mann–Okubo type if unitary symmetry were violated in a random way. For instance, by taking seriously the once popular idea that the pion-baryon couplings are “strong,” we may increase uniformly all pion-baryon coupling constants that appear in (11) leaving the  $K$  baryon and the  $\eta$  baryon coupling constants unchanged; the result we get for the baryon mass levels in lowest order is quite different from the Gell-Mann relation (1).<sup>14</sup> Indeed, the most remarkable aspect of the “eight-fold way” is not so much the approximate symmetry itself, but the singularly elegant way in which the symmetry is broken.

As another, perhaps more esoteric, example, let us consider a model in which we postulate the existence of a scalar meson octet, say  $\pi'$ ,  $K'$ ,  $\bar{K}'$ ,  $\chi'$ , and the non-invariance of the physical vacuum under unitary symmetry. In such a model, the vacuum expectation value of the  $T=0$   $\chi'$  field may not necessarily vanish; if so, the famous “tadpole” mechanism,<sup>15–17</sup> symbolically represented by Fig. 1, will give rise to the unitary-symmetry mass formula.

### III.

None of the mechanisms discussed in the previous section appear to simultaneously satisfy the requirements of aesthetical appeal and physical plausibility. In fact, until recently, it has been rather difficult to construct a realistic symmetry-breaking interaction that gives rise to the Gell-Mann–Okubo mass formula. (Okubo himself gave no examples of  $H_A$  in his paper.<sup>9</sup>) Fortunately, the very recent discovery of the 1020-MeV meson by the BNL-Syracuse group<sup>18</sup> with exactly the same quantum numbers ( $T=0$ ,  $J^{PC}=1^{--}$ ) as the 780-MeV  $\omega$  meson enables us to construct a more natural and realistic mechanism that may account for the success of the Gell-Mann–Okubo mass formula.

Whenever we have two strongly interacting states with the same quantum numbers, it is, in general, impossible to prevent mixing between them unless there exists a strict selection rule that forbids such a mixing.

<sup>14</sup> In the first paper of Ref. 10, S. L. Glashow and J. J. Sakurai state that the mass formula follows to lowest order in any symmetry breaking interaction. This statement is obviously incorrect. In contrast the global-symmetry mass formula of M. Gell-Mann [Phys. Rev. **106**, 1296 (1957)] and D. Kleitman [Phys. Rev. **107**, 1453 (1957)]  $\frac{1}{2}(m_N + m_\Sigma) = \frac{1}{2}(m_\Lambda + 3m_\Xi)$  is true to lowest order in any asymmetric  $K$  couplings.

<sup>15</sup> J. Schwinger, Ann. Phys. (N. Y.) **2**, 407 (1957).

<sup>16</sup> A. Salam and J. C. Ward, Phys. Rev. Letters **5**, 390 (1960).

<sup>17</sup> A. Salam, Rev. Mod. Phys. **33**, 428 (1961). See also J. Goldstone, Nuovo Cimento **19**, 154 (1961).

<sup>18</sup> L. Bertanza, V. Brisson, P. L. Connolly *et al.* Phys. Rev. Letters **9**, 180 (1962); P. Schlein, W. E. Slater, L. T. Smith, D. H. Stork, and H. K. Ticho, *ibid.* **10**, 368 (1963); P. L. Connolly E. L. Hart, K. W. Lai *et al.*, *ibid.* **10**, 371 (1963).

In the case of  $\omega$  and  $\varphi$ , exact unitary symmetry will forbid  $\omega$ - $\varphi$  mixing, but we know that in the real world, unitary symmetry is only approximate. So the observed 780-MeV  $\omega$  meson and the 1020-MeV  $\varphi$  meson are expected to be linear superpositions of the form

$$\begin{aligned} |\varphi\rangle &= \cos\lambda |\varphi^{(0)}\rangle + \sin\lambda |\omega^{(0)}\rangle, \\ |\omega\rangle &= -\sin\lambda |\varphi^{(0)}\rangle + \cos\lambda |\omega^{(0)}\rangle, \end{aligned} \quad (13)$$

where  $\omega^{(0)}$  transforms like a pure unitary singlet, and  $\varphi^{(0)}$  is the  $T=0$  member of a pure unitary octet (whose other members are  $\rho^{\pm,0}$ ,  $M^{+,0}$ ,  $M^-$ , and  $\bar{M}^0$ ). In writing down (13), we have assumed that there are no vector mesons other than  $\rho$ ,  $\bar{M}$ ,  $M$ ,  $\varphi$ , and  $\omega$ . The observed  $\omega$  and  $\varphi$  are, of course, eigenstates of the mass-squared operator which is diagonal in the  $\varphi$ - $\omega$  representation. On the other hand, the mass squared operator is not diagonal in the  $\varphi^{(0)}$ - $\omega^{(0)}$  representation.

More formally speaking, the two Proca equations for the  $\varphi^{(0)}$  and  $\omega^{(0)}$  “fields” (which are assumed to be coupled to conserved currents) can be written as

$$(\square^2 - \mathfrak{M}^2) \begin{pmatrix} \varphi_\mu^{(0)} \\ \omega_\mu^{(0)} \end{pmatrix} = - \begin{pmatrix} J_\mu^{(8)} \\ J_\mu^{(1)} \end{pmatrix}, \quad (14)$$

where

$$\mathfrak{M}^2 = \begin{pmatrix} m_\varphi^{(0)2} & m_{\varphi\omega}^2 \\ m_{\varphi\omega}^2 & m_\omega^{(0)2} \end{pmatrix}. \quad (15)$$

Here  $J_\mu^{(8)}$  and  $J_\mu^{(1)}$  respectively transform like the  $T=0$  member of a unitary octet and a unitary singlet. The off-diagonal elements  $m_{\varphi\omega}^2$  (which can be taken as real and positive in the stable-particle approximation by suitably adjusting the phase of the  $\varphi^{(0)}$  state) characterize the strength of the transition

$$\varphi^{(0)} \rightleftharpoons \omega^{(0)}.$$

In the Hamiltonian formalism, the presence of  $m_{\varphi\omega}^2$  in  $\mathfrak{M}^2$  implies the existence of a symmetry-breaking interaction

$$H_A = \frac{1}{2} m_{\varphi\omega}^2 \{ \omega_\mu^{(0)} \varphi_\mu^{(0)} + \varphi_\mu^{(0)} \omega_\mu^{(0)} \}. \quad (16)$$

We are not necessarily suggesting that there exists a “fundamental” interaction of the form (16) in our Lagrangian. It may well be that exact  $SU(3)$  symmetry is dynamically unstable against  $\omega$ - $\varphi$  mixing, and a phenomenological interaction of the form (16) emerges “spontaneously,” even though the theory itself is completely symmetric to start with, along the lines suggested by Heisenberg,<sup>19</sup> Nambu,<sup>20</sup> Baker and Glashow,<sup>21</sup> and many others. In any case, from an immediate practical point of view, it does not make too much

<sup>19</sup> W. Heisenberg, Z. Naturforsch. **14**, 441 (1959).

<sup>20</sup> Y. Nambu, in *Proceedings of the 1960 Annual International Conference on High-Energy Physics at Rochester*, edited by E. C. G. Sudarshan, Z. H. Tinslot, and A. C. Melissinos (Interscience Publishers, Inc., New York, 1960) p. 858; Y. Nambu and G. Jona-Lasinio, Phys. Rev. **122**, 345 (1961).

<sup>21</sup> M. Baker and S. L. Glashow, Phys. Rev. **128**, 2462 (1962).

difference whether we regard (16) as "fundamental" or "phenomenological."

In the subsequent sections, we calculate the self-energies of the various strongly interacting particles by taking (16) seriously. To the extent that (16) satisfies the Okubo requirement of transforming like the  $T=0$  member of a unitary octet, it is of no surprise that we obtain the Gell-Mann-Okubo mass formula in lowest order. But as we go along, we will encounter other interesting features unique to the  $\omega$ - $\varphi$  mixing model.

#### IV.

Let us start with the self-energies of the pseudoscalar mesons. Using charge conjugation invariance and unitary symmetry, we readily see that the only simple diagrams (involving two-particle intermediate states) that give rise to lowest-order violations of unitary symmetry are of the type shown in Fig. 2(a). Now, the trilinear interaction between the pseudoscalar meson

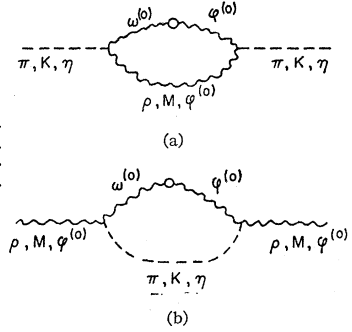

FIG. 2. Mechanism responsible for the mass formula for the pseudoscalar mesons (a) and the vector mesons (b).

octet and the vector meson octet of the pseudoscalar-vector-vector form is unique; it must necessarily be the kind Gell-Mann calls the  $D$  type:

$$\sqrt{2}g_1[\text{Tr}(\mathcal{U}\mathcal{P}\mathcal{U}) + \text{Tr}(\mathcal{U}\mathcal{U}\mathcal{P})] = 2^{3/2}g_1 \text{Tr}(\mathcal{U}\mathcal{U}\mathcal{P}), \quad (17)$$

where

$$\mathcal{U} = \begin{bmatrix} (\rho^0/\sqrt{2}) + (\varphi^{(0)}/\sqrt{6}) & \rho^+ & M^+ \\ \rho^- & (-\rho^0/\sqrt{2}) + (\varphi^{(0)}/\sqrt{6}) & M^0 \\ M^- & M^0 & -(2/\sqrt{6})\varphi^{(0)} \end{bmatrix}. \quad (18)$$

The couplings among the vector octet, the pseudoscalar octet, and the vector singlet are also unique:

$$g_0\omega^{(0)} \text{Tr}(\mathcal{P}\mathcal{U}). \quad (19)$$

The space properties of the vertices in both cases must be of the form

$$i\epsilon_{\mu\nu\lambda\sigma}k_\mu^{(1)}\epsilon_\nu^{(1)}k_\lambda^{(2)}\epsilon_\sigma^{(2)}, \quad (20)$$

where  $k^{(1)}$  ( $k^{(2)}$ ) and  $\epsilon^{(1)}$  ( $\epsilon^{(2)}$ ) refer to the four-momentum and the four-polarization vector of the vector meson 1 (2). Using

$$g(\pi^+\varphi^{(0)}\rho^-):g(K^+\varphi^{(0)}M^-):g(\eta\varphi^{(0)}\varphi^{(0)}) \\ = 2/\sqrt{3}: -1/\sqrt{3}: -2/\sqrt{3}, \quad (21)$$

which follows from (17), we can readily write down the self-energies for the pseudoscalar mesons due to Fig. 2(a):

$$\delta m_\pi^2 = (2/\sqrt{3})g_0g_1m_{\varphi\omega}^2I^{(1)}, \\ \delta m_K^2 = -(1/\sqrt{3})g_0g_1m_{\varphi\omega}^2I^{(1)}, \\ \delta m_\eta^2 = -(2/\sqrt{3})g_0g_1m_{\varphi\omega}^2I^{(1)}, \quad (22)$$

where  $I^{(1)}$  is an integral common to all three meson states. Eq. (22) is, of course, completely equivalent to the mass formula (2). Note that it is (mass)<sup>2</sup>, rather than just the mass that arises naturally, in agreement with Feynman.<sup>22</sup>

We now consider the vector-meson octet. We again have only one kind of simple symmetry-breaking dia-

grams, as shown in Fig. 2(b). Using (21), we obtain

$$\delta m_\rho^2 = (2/\sqrt{3})g_0g_1m_{\varphi\omega}^2I^{(2)}, \\ \delta m_M^2 = -(1/\sqrt{3})g_0g_1m_{\varphi\omega}^2I^{(2)}, \\ \delta[m_{\varphi^{(0)}}]^2 = -(2/\sqrt{3})g_0g_1m_{\varphi\omega}^2I^{(2)}, \quad (23)$$

leading to

$$m_M^2 = \frac{1}{4}\{3[m_{\varphi^{(0)}}]^2 + m_\rho^2\}. \quad (24)$$

There is a well-known theorem based on the Lehmann spectral representation that states that the self-energies of interacting bosons must be negative.<sup>23-25</sup> In our case, the sign of  $g_0$  and  $g_1$  are not known, and this general theorem is not directly applicable. However, we know that the general theorem would be applicable if the internal  $\varphi^{(0)}$  line were replaced by an  $\omega^{(0)}$  line (which physically means that we are considering an  $\omega^{(0)}$ - $\omega^{(0)}$  junction due to, say, baryon pairs, in place of the  $\omega^{(0)}$ - $\varphi^{(0)}$  junction). So both  $I^{(1)}$  and  $I^{(2)}$  must be negative. Since the coupling constants  $g_0$  and  $g_1$  are common to Figs. 2(a) and 2(b), we get the interesting result

$$(m_M - m_\rho)(m_K - m_\pi) > 0. \quad (25)$$

In other words, if we take seriously the idea that the meson mass differences within the unitary multiplets are due to Fig. 2(a) and 2(b), then we can actually "predict" that the  $M$  ( $=K^*$  888) mass must be higher than the  $\rho$ (750) mass, provided the  $K$ (495) mass is

<sup>23</sup> H. Lehmann, *Nuovo Cimento* **11**, 343 (1954).

<sup>24</sup> W. E. Thirring, *Principles of Quantum Electrodynamics* (Academic Press Inc., New York 1958), Chap. 14.

<sup>25</sup> K. Johnson, *Nucl. Phys.* **25**, 435 (1961).

<sup>22</sup> R. P. Feynman (private communication).

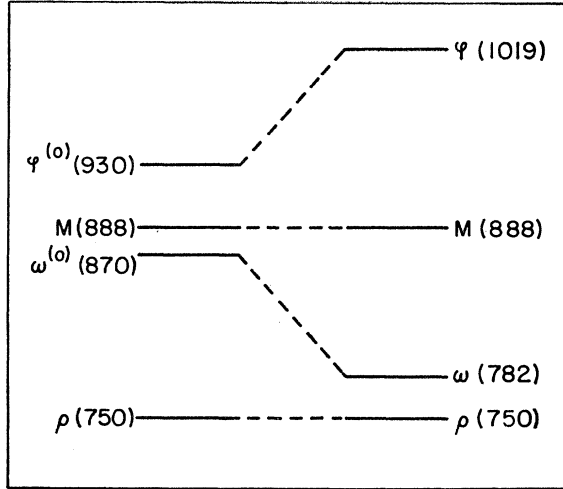

FIG. 3. Energy-level diagram for the vector mesons.

higher than the  $\pi(137)$  mass. This agrees with observation.

Equation (24) gives a  $\varphi^{(0)}$  mass of 930 MeV when the observed  $\rho$  and the  $M$  mass are substituted. This value is to be compared with the observed  $\varphi$  and  $\omega$  mass of 1020 and 782 MeV, respectively. It has already been argued that this discrepancy may be attributed to  $\omega$ - $\varphi$  mixing.<sup>1,26</sup>

In the presence of a strong  $\omega$ - $\varphi$  mixing we cannot directly observe  $m_{\varphi^{(0)}}$ . But from the computed  $m_{\varphi^{(0)}}$  and the observed  $m_{\omega}$  and  $m_{\varphi}$  we can solve for the mixing angle  $\lambda$  that appears in Eq. (13). All we have to note is that the matrix

$$\begin{pmatrix} \cos\lambda & \sin\lambda \\ -\sin\lambda & \cos\lambda \end{pmatrix} \quad (26)$$

transforms the  $\mathfrak{M}^2$  matrix (15) into the diagonal form,

$$\begin{pmatrix} m_{\varphi}^2 & 0 \\ 0 & m_{\omega}^2 \end{pmatrix} = \begin{pmatrix} m_{\varphi^{(0)2}} + m_{\varphi\omega}^2 & 0 \\ 0 & m_{\omega^{(0)2}} - m_{\varphi\omega}^2 \end{pmatrix}. \quad (27)$$

Solving this straightforward eigenvalue problem, we have

$$\tan 2\lambda = \frac{[(m_{\varphi}^4 - m_{\varphi^{(0)4}})(m_{\omega^{(0)4}} - m_{\omega}^4)]^{1/2}}{2m_{\varphi^{(0)2}} - m_{\varphi}^2 + m_{\omega}^2}. \quad (28)$$

Numerically we obtain  $\lambda \approx 38^\circ$ . This means that the observed 1020-MeV  $\varphi$  meson is the  $T=0$  member  $\varphi^{(0)}$  of the vector-meson octet 61% of the time (in intensity) and the unitary singlet  $\omega^{(0)}$  39% of the time.<sup>27</sup> It is important to note that despite the approximate mass degeneracy between  $\omega$  and  $\rho$ , the 782-MeV  $\omega$  meson is the  $T=0$  member of the vector meson octet only 39% of the time. Figure 3 summarizes the situation.

<sup>26</sup> J. J. Sakurai, Phys. Rev. Letters **9**, 472 (1962).

<sup>27</sup> This point has been discussed independently by J. Kalckar (to be published).

From a more practical point of view, a knowledge of  $\lambda$  is of some interest in connection with the partial decay width of the process

$$\varphi \rightarrow K + \bar{K}.$$

Previously, we have remarked that the partial width for this process would be 3.2 MeV if the  $\varphi$  were the  $T=0$  member of the vector-meson octet, and zero if the  $\varphi$  were a unitary singlet.<sup>26</sup> A mixing angle of  $39^\circ$  then implies

$$\Gamma(\varphi \rightarrow K + \bar{K}) \approx 1.9 \text{ MeV},$$

which is not in contradiction with the data of the BNL-Syracuse and UCLA groups<sup>18</sup>:

$$\Gamma_{\text{tot}} \approx 1_{-1}^{+2} \text{ MeV} \quad (\Gamma_{\text{tot}} > 0) \quad \text{BNL-Syracuse}$$

$$\Gamma_{\text{tot}} \lesssim 5 \text{ MeV} \quad \text{UCLA}$$

$$\Gamma(\varphi \rightarrow \rho + \pi) / \Gamma(\varphi \rightarrow K + \bar{K}) = 0.35 \pm 0.2 \quad \text{BNL-Syracuse}$$

## V.

We now turn our attention to the baryon mass differences. As far as the couplings of the unitary-singlet vector meson  $\omega^{(0)}$  to the baryons are concerned, there is no ambiguity; omitting the  $\gamma_{\mu}$ 's and the  $\sigma_{\mu\nu}$ 's, we have the unique form

$$f_B \omega^{(0)} \text{Tr}(\bar{\mathfrak{B}}\mathfrak{B}) = f_B \omega^{(0)} [\bar{p}p + \bar{n}n + \bar{\Lambda}\Lambda + \bar{\Sigma}^+\Sigma^+ + \dots]. \quad (29)$$

Note that it is impossible to couple the  $\omega^{(0)}$  meson to bilinear vector currents constructed out of the pseudo-scalar fields in a unitary symmetric way and that at zero-momentum transfer, the  $\sigma_{\mu\nu}$  couplings of the type (29), as well as couplings of the type  $\omega^{(0)} \text{Tr}(\mathcal{P}\mathcal{U})$ , [cf., Eq. (20)] vanish. So the unitary-singlet vector meson  $\omega^{(0)}$  is precisely the kind coupled "universally" to the baryon current.<sup>4,28</sup>

In contrast to the couplings of the unitary singlet, the couplings of the vector meson octet to the baryon octet are not unique. Omitting the  $\gamma_{\mu}$ 's and the  $\sigma_{\mu\nu}$ 's, we have,<sup>1</sup> for the effective Lagrangian,

$$\sqrt{2}\gamma [\beta \text{Tr}(\bar{\mathfrak{B}}\mathcal{U}\mathfrak{B} + \bar{\mathfrak{B}}\mathfrak{B}\mathcal{U}) + (1-\beta) \text{Tr}(\bar{\mathfrak{B}}\mathcal{U}\mathfrak{B} - \bar{\mathfrak{B}}\mathfrak{B}\mathcal{U})]. \quad (30)$$

As is well known, one of the most attractive features of the octet version of unitary symmetry is that it can accommodate, in a very natural and elegant manner, the vector mesons coupled to the exactly conserved isospin and hypercharge currents<sup>3,4,29</sup> together with strangeness-bearing  $M$  mesons coupled to partially conserved strangeness-changing currents. In order that this attractive feature be realized, however, the  $\gamma_{\mu}$  couplings of the  $D$  type must necessarily vanish at

<sup>28</sup> Y. Fujii, Progr. Theoret. Phys. (Kyoto) **21**, 232 (1959).

<sup>29</sup> In contrast, in the vector meson theory of A. Salam and J. C. Ward<sup>6</sup> based on the symmetric Sakata model, the  $T=0$  member of the vector-meson octet is not coupled to the hypercharge current.

zero-momentum transfer, or in the language of (30),  $\beta$  must be zero for the Dirac form factor at zero-momentum transfer. Even within the framework of such a theory, it is possible that the  $\gamma_\mu$  couplings at finite momentum transfer and the  $\sigma_{\mu\nu}$  couplings contain  $D$  type components, especially if the couplings of the pseudoscalar octet to the baryon octet involve a mixture of  $D$  and  $F$  (as suggested by the dynamical calculations of Martin and Wali,<sup>30</sup> Cutkosky,<sup>31</sup> and others<sup>32,33</sup> based on the idea that the observed  $J = \frac{3}{2}^+$  baryon isobars are due to attractive forces generated by Yukawa-type couplings of the pseudoscalar mesons) or, more generally speaking, if  $R$  (hypercharge-reflection) invariance is violated. We may recall that a similar situation exists in the couplings of the  $A_\mu$  field to the neutron; although the  $\gamma_\mu$  coupling of the photon to the neutron must be *strictly* zero at zero-momentum transfer, its  $\sigma_{\mu\nu}$  coupling need not (and, in fact, does not) vanish.

We calculate the baryon mass differences using Fig. 4(a) to obtain

$$\begin{aligned}\delta m_N &= f_B \gamma [\sqrt{3}(1-\beta) - (\beta/\sqrt{3})] m_{\varphi\omega}^2 I^{(3)}, \\ \delta m_\Lambda &= -(2f_B \gamma \beta/\sqrt{3}) m_{\varphi\omega}^2 I^{(3)}, \\ \delta m_\Sigma &= (2f_B \gamma \beta/\sqrt{3}) m_{\varphi\omega}^2 I^{(3)}, \\ \delta m_\Xi &= f_B \gamma [-\sqrt{3}(1-\beta) - (\beta/\sqrt{3})] m_{\varphi\omega}^2 I^{(3)},\end{aligned}\quad (31)$$

where  $\beta$ ,  $\gamma$ , and  $f_B$  now represent some kind of "over-all" mixing parameter and coupling constants that simulate and average over the effects due to the  $\gamma_\mu$  and the  $\sigma_{\mu\nu}$  couplings with appropriate form factors. Equation (31) immediately gives the Gell-Mann mass formula (1).

It is interesting to note that if we had pure  $F$ -type couplings (corresponding to  $\beta=0$ ) for both the  $\gamma_\mu$  and  $\sigma_{\mu\nu}$  couplings for all  $q^2$ , then we would have an equal spacing rule

$$m = m_0'(1 + a'Y), \quad (32)$$

even for the baryon octet with  $\Lambda$  and  $\Sigma$  being degenerate. The actual experimental situation is not too far from this:

$$\begin{aligned}m_\Xi - m_N &= 380 \text{ MeV}, \\ m_\Sigma - m_\Lambda &= 75 \text{ MeV}.\end{aligned}$$

If we solve for the "average" mixing parameter  $\beta$  in (31) using the observed baryon mass differences, we obtain

$$\begin{aligned}\beta &\approx -0.4, \\ (\beta/1-\beta)^2 &\approx 0.09,\end{aligned}$$

which corresponds to a mixing angle of  $78^\circ$  (to be compared with  $90^\circ$  for pure  $F$ ;  $0^\circ$  for pure  $D$ ) in Cutkosky's notation.<sup>31</sup> In obtaining this value we have ignored many effects; for instance, the internal baryon line in Fig. 4(a) may be replaced by a line corresponding to

<sup>30</sup> A. W. Martin and K. C. Wali, Phys. Rev. **130**, 2455 (1963).

<sup>31</sup> R. E. Cutkosky (to be published).

<sup>32</sup> R. H. Capps, Nuovo Cimento **27**, 1208 (1963).

<sup>33</sup> Y. Hara and Y. Miyamoto (to be published).

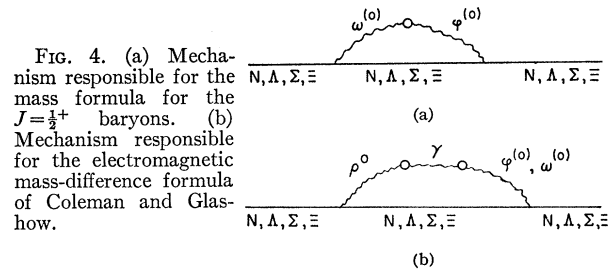

any baryon isobar that transforms like a unitary octet (fortunately, the lowest-lying  $J = \frac{3}{2}^+$  isobars, being members of a decuplet, do not contribute). For this reason, it might not be too meaningful to attach much significance to our numerical value of  $\beta$ . It is, however, gratifying from the conserved-vector point of view that the  $F$ -type couplings are dominant, on the average, if we take Fig. 4(a) seriously.

Before we leave the subject of the stable  $J = \frac{1}{2}^+$  baryon octet, we briefly comment on the electromagnetic-mass-difference formula of Coleman and Glashow<sup>34</sup>:

$$m(\Xi^-) - m(\Xi^0) + m(n) - m(p) = m(\Sigma^-) - m(\Sigma^+), \quad (33)$$

which gives a  $\Xi^- - \Xi^0$  mass difference of 5.2 MeV, in rough agreement with the very preliminary experimental data.<sup>35,36</sup> The point of view that the mass differences within a unitary multiplet are due to  $\omega$ - $\varphi$  mixing naturally leads us to the speculation that the mass differences within an isospin multiplet are also due to vector-particle mixings. To the extent that  $\rho^0$ ,  $\omega$ ,  $\varphi$ , and the photon are all vector particles with  $Q=0$ ,  $C=-1$ ,  $J^P=1^-$ , electromagnetic mixing among them, e.g.,  $\rho^0 \rightarrow \gamma \rightarrow \omega$ , may be appreciable.<sup>37</sup> For this reason, it is conceivable that mechanisms of the type shown in Fig. 4(b), which lead to the Coleman-Glashow formula irrespective of the relative strength of the  $\rho^0 \leftrightarrow \gamma$ ,  $\omega^{(0)} \leftrightarrow \gamma$ ,  $\varphi^{(0)} \leftrightarrow \gamma$  amplitudes, may account for the major parts of the electromagnetic mass differences within isospin multiplets.

## VI.

It has already been suggested that the low-lying  $J = \frac{3}{2}^+$  baryons  $N_{3/2}^*(1235)$ ,  $Y_1^*(1380)$ , and  $\Xi_{1/2}^*(1530)$  belong to the tenfold representation of  $SU(3)$  together with a metastable  $Y=-2$ ,  $T=0$  hyperon predicted at 1685 MeV. The mass formula for this representation reduces to the famous equal-spacing rule (32), which seems to be very well satisfied.

More recently, Martin and Wali<sup>30</sup> have performed an approximate multichannel  $N/D$  calculation to obtain

<sup>34</sup> S. Coleman and S. L. Glashow, Phys. Rev. Letters **6**, 423 (1961).

<sup>35</sup> F. Solmitz, Bull. Am. Phys. Soc. **7**, 610 (1962); D. H. Stork, *ibid.* **8**, 46 (1963).

<sup>36</sup> J. Leitner (private communication), based on the work of the BNL-Syracuse group.

<sup>37</sup> See, for example, S. L. Glashow, Phys. Rev. Letters **7**, 469 (1961); Y. Nambu and J. J. Sakurai, *ibid.* **8**, 79 (1962).

the positions, as well as the widths, of the  $J=\frac{3}{2}^+$  baryons. In their calculations,  $N$  is approximated by the Born matrix corresponding to the exchange of baryons in pseudoscalar meson-baryon scattering amplitudes, and the dynamical  $J=\frac{3}{2}^+$  resonances emerge as zeros of the determinant of  $D$ . The observed *asymmetric* masses of the pseudoscalar mesons and the baryons and unitary-*symmetric* coupling constants are used as input parameters. Their work indicates that the calculated positions for the  $J=\frac{3}{2}^+$  isobars satisfy the equal-spacing rule to an accuracy of about 30%.

On the other hand, it is likely that the observed masses of the  $J=\frac{3}{2}^+$  baryons satisfy the equal-spacing rule much more exactly than such  $N/D$  calculations indicated. Therefore, it is worth examining an alternative approach to the mass levels of the  $J=\frac{3}{2}^+$  decuplet.

Unlike Martin and Wali, we do not propose to "explain" the existence of the  $J=\frac{3}{2}^+$  decuplet. Instead, let us just assume that the  $J=\frac{3}{2}^+$  baryons exist and that they are degenerate before we turn on  $\omega$ - $\varphi$  mixing. We again compute the self-energy contributions from diagrams of the type Fig. 4(a) where the  $J=\frac{1}{2}^+$  baryons are now replaced by  $J=\frac{3}{2}^+$  baryons. Now, in contrast to (30), the unitary symmetric couplings of the vector-meson octet to the bilinear currents formed out of the  $J=\frac{3}{2}^+$  decuplet turn out to have a unique form. This follows from the decomposition

$$10 \times 10^* = 1 + 8 + 27 + 64, \quad (34)$$

in which the **8** appears only once. (In contrast the **8** appears twice in the decomposition of the product  $8 \times 8$ .) Meanwhile, the idea that the  $\varphi^{(0)}$  is coupled to the hypercharge (which transforms like the  $T=0$  member of a unitary octet) is consistent with unitary symmetry (even though it is not necessarily required by it). Since there is only one way to couple the  $\varphi^{(0)}$  to the baryon decuplet, the strength of the coupling of the  $\varphi^{(0)}$  to the  $J=\frac{3}{2}^+$  baryon must necessarily be proportional to the hypercharge  $Y$  in *any* theory based on the octet version of unitary symmetry. As for the unitary singlet  $\omega^{(0)}$ , it must, of course, be coupled "universally" to each member of the  $J=\frac{3}{2}^+$  decuplet. Therefore, our  $\omega$ - $\varphi$  mixing model immediately gives the equal-spacing rule (32).

### VII.

We have succeeded in obtaining various mass formulas of the Gell-Mann-Okubo type by considering graphs in which the  $\omega^{(0)}$ - $\varphi^{(0)}$  junction appears only once. The reader may naturally ask: What about the corrections to the mass formulas due to graphs in which the  $\omega^{(0)}$ - $\varphi^{(0)}$  junction appears more than once.

In our model, the problem of justifying the unitary-symmetry mass formula is essentially the same as the problem of justifying perturbation theory with the perturbation Hamiltonian

$$\frac{1}{2} m_{\varphi\omega}^2 [\omega_{\mu}^{(0)} \varphi_{\mu}^{(0)} + \varphi_{\mu}^{(0)} \omega_{\mu}^{(0)}],$$

where the coupling constant  $m_{\varphi\omega}^2$  is numerically equal to

$$m_{\varphi\omega}^2 = m_{\varphi}^2 - [m_{\varphi}^{(0)}]^2 = 0.17 \text{ BeV}^2.$$

Therefore, the dimensionless constant that characterizes the strength of the perturbation is

$$m_{\varphi\omega}^2 / \langle m^2 \rangle_{\text{av}}$$

where  $\langle m^2 \rangle_{\text{av}}$  is some characteristic-mass squared. The larger  $\langle m^2 \rangle_{\text{av}}$  is, the less surprising will be the success of the mass formula.

The self-energy diagrams considered in the previous sections are badly divergent.<sup>38</sup> So just from dimensional considerations, we see that diagrams in which the  $\omega^{(0)}$ - $\varphi^{(0)}$  junction appears twice are less divergent than similar diagrams in which the  $\omega^{(0)}$ - $\varphi^{(0)}$  junction appears only once, by a factor of  $m_{\varphi\omega}^2/\Lambda^2$ , where  $\Lambda$  is of the order of the cutoff momentum, or, more generally, the typical virtual momentum responsible for the dominant contributions to the self energies. With  $\Lambda$  of the order of 2 BeV/ $c$ , we have

$$m_{\varphi\omega}^2/\Lambda^2 \sim 4\%,$$

which is not very large [especially if we recall that the right-hand and left-hand sides of the Gell-Mann formula (1) differ by as much as 7 MeV which is to be compared to the observed  $\Lambda N$  mass difference of 175 MeV]. In other words, we have a plausible explanation of the success of the Gell-Mann-Okubo mass formula, provided the major contributions to the self-energy integrals come from virtual momenta of the order of a few BeV/ $c$  or greater.

### VIII.

So far, we have considered only diagrams with  $\omega^{(0)}$ - $\varphi^{(0)}$  junctions. Once we have mass differences in one unitary multiplet, diagrams that may "look" unitary symmetric can produce symmetry-violating effects in some other unitary multiplet. For this reason, let us study, as an example, the effect of the baryon mass differences on the pseudoscalar meson self energies.

We have, for the self energies of the  $i$ th meson,

$$\delta m_i^2 = \sum_{jk} \frac{2ig_{ijk}^2}{(2\pi)^4} \int d^4p \times \text{Tr} \left\{ \gamma_5 \frac{1}{i\gamma \cdot p + m_j} \gamma_5 \frac{1}{i\gamma \cdot (p-k) + m_k} \right\} \Big|_{k^2 = -m_i^2}, \quad (35)$$

where  $m_j$  and  $m_k$  refer to the actual asymmetric masses of the  $j$ th and  $k$ th baryons that appear in the lowest-order self-energy diagram. Let us expand the baryon

<sup>38</sup> The only exception to this remark is the baryon diagram of Fig. 3(a) with *pure*  $\gamma_{\mu}$ -type couplings.

propagator in powers of mass differences as follows:

$$\frac{1}{i\gamma \cdot p + m_j} = \frac{1}{i\gamma \cdot p + m_B} - \frac{\delta m_j}{(i\gamma \cdot p + m_B)^2} + \frac{(\delta m_j)^2}{(i\gamma \cdot p + m_B)^3} - \cdots, \quad (36)$$

$$\delta m_j \equiv m_j - m_B,$$

where  $m_B$  is some reference mass which may be taken to be  $\frac{1}{2}(m_N + m_\Sigma)$ . We can then write

$$\delta m_i^2 = C_i^{(0)} I_0 + \sum_j C_{ij}^{(1)} \delta m_j I_1 + \sum_{jk} C_{ijk}^{(2)} (\delta m_j)(\delta m_k) I_2 + \cdots, \quad (37)$$

where  $C_i^{(0)}$ ,  $C_{ij}^{(1)}$ , and  $C_{ijk}^{(2)}$  can be expressed in terms of the coupling constants  $g_{ijk}$ , and  $I_0$ ,  $I_1$ , and  $I_2$  are integrals that depend only on  $m_B$  and the cutoff  $\Lambda$ .

If  $g_{ijk}^2$  satisfy the requirements imposed by unitary symmetry, the zeroth-order term  $C_i^{(0)} I_0$  is independent of  $i$  and does not give rise to meson mass differences. It is easy to show (by group-theoretic considerations or by explicit calculations) that the first-order term  $\sum_j C_{ij}^{(1)} \delta m_j I_1$  gives rise to the meson mass differences that satisfy the octet mass formula (2) provided we start with the baryon mass differences that satisfy the mass formula and the coupling constants that obey unitary symmetry. Conversely, if we start with the pseudoscalar mesons whose mass differences satisfy the mass formula, then we can generate, by considering baryon self-energy diagrams, baryon mass differences that satisfy the mass formula (1) to first order in  $\delta m_i^2$ . Thus, a pair of mass formulas of the Gell-Mann-Okubo type are "self-consistent" if we terminate the series at this stage.

It is crucial to note the degrees of divergence of the integrals that appear in (37). The zeroth-order term is quadratically divergent; the first-order term, which is really responsible for the mass formula, is only linearly divergent; the second-order term, which violates the mass formula, is only logarithmically divergent; and the rest gives convergent results. In other words, the corrections to the mass formula are expected to be of the order of  $\delta m_j/\Lambda$ . So, once again, for large values of  $\Lambda$ , the success of the Gell-Mann-Okubo formula is not too mysterious.<sup>39</sup>

Although we have used the language of perturbation theory both in this section and in the previous sections, we feel that, even in a more realistic treatment of the mass-difference problem, one of the necessary conditions for the success of the unitary-symmetry mass formula is

<sup>39</sup> S. L. Glashow [Phys. Rev. **130**, 2132 (1963)] also emphasizes the role played by the smallness of  $\delta m_j/\Lambda$  in his attempt to understand the success of the mass formula within the framework of a four-fermion model in which unitary symmetry is broken "spontaneously."

the existence of substantial contributions from high-energy or high-mass states.

## IX.

To summarize, we have shown that  $\omega$ - $\varphi$  mixing provides a very natural symmetry-breaking mechanism that leads to the mass formula of Gell-Mann and Okubo. Some of the distinctive features of our model are the following:

(a) The model does not require the existence of any additional particle or resonance yet to be discovered.

(b) We must have  $m_\rho < m_M$  provided  $m_\pi < m_K$ , where Figs. 2(a) and 2(b) are assumed.

(c) The failure of the mass formula for the vector mesons is not surprising.

(d) The model leads to  $|m_\Sigma - m_N| \gg |m_\Sigma - m_\Lambda|$  provided the couplings of the vector mesons to the baryons are predominantly of the  $F$  type (as expected from the conserved-vector-current point of view), where Fig. 4(a) is assumed.

(e) The mass formula of Coleman and Glashow can be explained along similar lines.

(f) We can justify the conjecture that it is more proper to use, in the mass formula,  $(\text{mass})^2$  for the mesons and just the mass for the baryons.

(g) The corrections to the mass formula are expected to be of the order of a few percent if the major contributions to the self-energies of strongly interacting states come from the region of a few BeV.

We have also shown in Sec. VIII that there is some kind of "self-consistency" between a pair of unitary-symmetry mass formulas provided contributions from high energies play important roles in determining the mass spectrum of strongly interacting particles.

We have not explained why there is  $\omega$ - $\varphi$  mixing to start with. But this might not necessarily be regarded as a defect of the model; after all, nobody has succeeded in explaining why the electromagnetic couplings destroy charge independence in such a way that  $Q$  is equal to  $T_3 + \frac{1}{2}Y$ .

*Note added in proof.* In writing down Eq. (27) we have assumed that  $m_\varphi^{(0)2} \approx m_\omega^{(0)2}$ . More precisely, we should have

$$m_\varphi^2 = \frac{1}{2}(m_\omega^{(0)2} + m_\varphi^{(0)2}) + [m_\varphi^4 + \frac{1}{4}(m_\varphi^{(0)2} - m_\omega^{(0)2})^2]^{1/2}$$

$$m_\omega^2 = \frac{1}{2}(m_\omega^{(0)2} + m_\varphi^{(0)2}) + [m_\omega^4 + \frac{1}{4}(m_\varphi^{(0)2} - m_\omega^{(0)2})^2]^{1/2}.$$

This, however, does not significantly affect our numerical values of  $\lambda$  and  $m_\varphi^2$ . Meanwhile  $\omega$ - $\varphi$  mixing has recently been discussed by a number of authors: S. Okubo, Phys. Letters **5**, 165 (1963); S. L. Glashow, Phys. Rev. Letters **11**, 48 (1963); J. Ginibre (to be published).

## ACKNOWLEDGMENTS

It is a pleasure to thank Professor S. L. Glashow, Professor M. Gell-Mann, Dr. P. G. O. Freund, and Dr. A. P. Balachandran for many valuable discussions.