

Precision Lifetime Measurements on Positive and Negative Muons*

S. L. MEYER, E. W. ANDERSON, E. BLESER,† L. M. LEDERMAN,
J. L. ROSEN, J. ROTHBERG,‡ AND I-T. WANG

Columbia University, New York, New York

(Received 31 July 1963)

An experiment to measure and compare the free decay rates of positive and negative muons is described. Muons from the Nevis synchrocyclotron were stopped in a liquid-hydrogen target containing less than 1 ppm D₂ and less than 1 part in 10⁹ of other impurities. In this situation, the rate of μ⁻ capture in H₂ was the only significant correction to the free decay rate of μ⁻ and was measured in a separate experiment. The lifetimes were monitored by measuring the time intervals between muon stops and decay electrons using a transistorized digitron of 30-nsec channel width. Electronic circuitry of the "interference remover" type was employed to eliminate time-dependent background. μ⁻ and μ⁺ lifetimes were measured with the same apparatus and under essentially the same conditions of rate and geometry. The ratio of the lifetimes is expected to be particularly insensitive to any systematic errors. We have obtained: τ_{μ⁻} = 2.198 ± 0.002 μsec (hydrogen correction made), τ_{μ⁺} = 2.197 ± 0.002 μsec, R = τ_{μ⁻}/τ_{μ⁺} = 1.000 ± 0.001.

I. INTRODUCTION

THIS paper presents a description and the results of a measurement of the ratio of the lifetimes of the positive and negative muons as well as the absolute magnitudes. Preliminary results have been reported elsewhere.¹

The comparison of μ⁻ and μ⁺ lifetimes is motivated by the proof² that *CPT* invariance guarantees the equality of free decay lifetimes for particle and antiparticle. Since the *CPT* theorem rests upon very basic postulates of modern theory,³ sensitive experimental tests should be made. Sachs⁴ has suggested other tests based on the *K*₀-*K*₀ system and has stressed that an observation which fails to find a particle-antiparticle difference (as ours has) does not establish *CPT* invariance but only that either *CP* or *CPT* invariance in this reaction holds to the accuracy achieved. The experimental problem of a good comparison of particle-antiparticle lifetimes is made difficult by competing processes which occur when negative particles are brought to rest in matter. Thus, negative pions, kaons, etc., are hardly ever observed to decay at rest. The best previous comparison of particle-antiparticle lifetimes is that deduced from the μ⁺ lifetime and the μ⁻ lifetime extrapolated from measurement of disappearance rates in light nuclei.⁵ With the various uncertainties in the corrections due to capture rate, orbital motion, and binding energy, this comparison shows equality to within several percent. Only in the

case of muons stopping in hydrogen (or helium) is the perturbation small enough to permit a sensitive determination of τ_{μ⁻} comparable to τ_{μ⁺}. The capture-rate perturbation is of the order of 0.1% and has been determined to 8% in a separate experiment.⁶ Thus, by alternately stopping μ⁺ and μ⁻ in the same apparatus, it was possible to measure the ratio independent of any systematic bias which might have existed.

The theoretical interest in the free lifetime of the muon stems from the fact that its value can be predicted from the *ft* value of O¹⁴ on the hypothesis of a universal Fermi interaction (UFI) and the conserved vector current theory (CVC⁷). The closeness of the predicted and previously observed lifetimes is certainly enough to establish the essential validity of the theory, especially in view of the recent verification as observed in the decay spectra of B¹² and N¹².⁸ It is in fact the precise deviation of the two numbers (2 ± 0.5% after radiative corrections) that may teach us something new, be it the nuclear physics of O¹⁴ or intermediate boson corrections to the lifetime of the muon.

II. EXPERIMENTAL METHOD

A. Geometry and Beam

Figure 1 shows the arrangement of counters and hydrogen target. The counter labeled *N* was a liquid scintillation counter (NE213 viewed by an EMI 9530-B phototube). Counter *A* was 3/8-in. Pilot *B* scintillator viewed by a 6810A photomultiplier. In the concomitant measurement of the rate of muon capture in liquid hydrogen, the *N* served as a proton recoil neutron detector, while *A* acted as the anticounter. The *N* and *A* shown made up only one of a set of four such pairs symmetrically disposed around the hydrogen target. The

⁶ J. Rothberg, E. W. Anderson, E. Bleser, L. M. Lederman, S. L. Meyer, J. Rosen, and I-T. Wang, *Bull. Am. Phys. Soc.* **8**, 33 (1963); *Phys. Rev.* **132**, 2664 (1963).

⁷ R. P. Feynman and M. Gell-Mann, *Phys. Rev.* **109**, 193 (1958).

⁸ T. Mayer-Kuckuk and F. C. Michel, *Phys. Rev. Letters* **7**, 167 (1961); Y. K. Lee, L. W. Mo, and C. S. Wu, *ibid.* **10**, 253 (1963).

* Work supported in part by the Office of Naval Research.

† Present address: Brookhaven National Laboratory, Upton, New York.

‡ Present address: Yale University, New Haven, Connecticut.

¹ E. W. Anderson, E. Bleser, S. L. Meyer, J. Rosen, J. Rothberg, and I. T. Wang, *Proceedings of the International Conference on High Energy Physics, Geneva, 1962* (CERN Scientific Information Service, Geneva, Switzerland, 1962), p. 417.

² T. D. Lee and C. N. Yang, *Phys. Rev.* **105**, 1671 (1957); G. Luders and B. Zumino, *ibid.* **106**, 385 (1957).

³ W. Pauli, *Niels Bohr and the Development of Physics* (Pergamon Press, Ltd. London, 1955); G. Luders, *Kgl. Danske Vidensk. 28*, No. 5 (1954).

⁴ R. G. Sachs, *Phys. Rev.* **129**, 2280 (1963).

⁵ J. C. Sens, *Phys. Rev.* **113**, 679 (1959); D. D. Yovanovitch, *ibid.* **117**, 1580 (1960); M. Eckhause, Carnegie Institute of Technology Report NYO 9286 (February 1962).

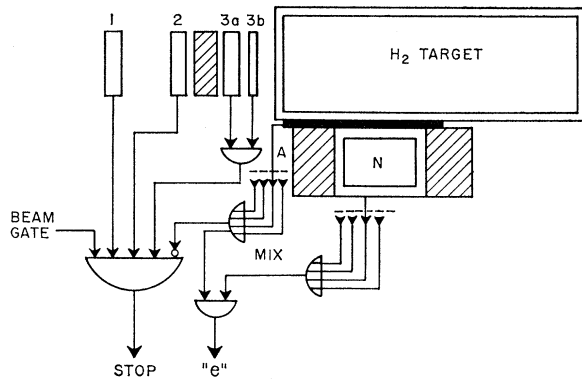

FIG. 1. Block diagram of the relevant electronics and counters used in this measurement.

absorber was so chosen that the beam particles of interest had a stopping distribution axially centered relative to the N counters. The μ^+ and μ^- lifetime measurements were frequently alternated. The absorber was varied so that "stops" for negative runs meant muon stops (purified muon beam) while pions were stopped in the case of the positive running. The synchrocyclotron vibrating target was used throughout with the optimum part of the spill being gated. There is no appreciable rf structure in this type of beam spill. The duty cycle (instantaneous rate/average rate) was ~ 3 . Decay electrons were indicated by a coincidence NA .

B. Time Measurement

The time intervals between "stops" and "e's" were monitored with a "digitron" or digital time analyzer⁹ designed in this laboratory by W. LeCroy and W. Sippach. The time base was produced by a 100 Mc/sec crystal-controlled cw oscillator. The intervals were measured by scaling the sinusoidal waves gated by start and stop pulses. The stability of the time base was checked to be better than 1 part in 10^5 over a period of days. Although the basic oscillator frequency was 100 Mc/sec, the channel time width was variable. The lifetime runs used a width of 30 nsec. Since the start and stop pulses were not coherent with the oscillator, there was an individual time jitter associated with each event. However, the frequency division was done after the start-stop gating and hence the effective resolution is described by a trapezoid with 40-nsec base and 20-nsec flat top.

The start and stop pulses were derived from the muon (pion) stop and the electron pulses via circuitry of the "interference remover" type. To eliminate time-dependent background, the two sets of pulses were purified separately. This is to say, no muon pulse was accepted if there was another pulse on the same line within 15 μ sec before or 8 μ sec after the pulse in question.

⁹ R. A. Swanson, Rev. Sci. Instr. 31, 149 (1960). See also Ref. 13.

The electron pulses were similarly and independently purified.

The principal functions of these rejection criteria are: (1) to eliminate events in which there is confusion as to which muon of a time cluster of pulses is responsible for a given electron; (2) eliminate events in which, for a given muon, there appears more than one candidate pulse for the electron, i.e., there is an electron and an accidental; (3) do all this in a manner which is essentially uncorrelated with the time difference between the muon stopping and the decay.

A schematic diagram of the interference remover logic is shown in Fig. 2. Other circuit functions: (1) provide a start-stop pair only if a purified electron follows a purified muon by less than 8 μ sec; (2) retim the pulses by having the logical outputs, which may have slight time jitter as a result of incoherent gating processes, gate the delayed "raw" input pulses. Since it was possible to utilize the parallel access to the RIDL analyzer memory used to store the 100-Mc/sec scaler outputs, a process which requires only 25 μ sec, no specific dead time circuitry was required other than that provided by the interference remover logic. In addition to permitting faster data storage than heretofore possible, this feature eliminates the need to restore the confusion circuitry after the dead time which can be a subtle and complicated business.

All the electronic circuits were of a modular, plug-in type.

C. Background Effects

The absence of beam structure in the gated part of the vibrating target spill, together with the interference remover logic, insures that any residual background is constant in time. This background arises from the presence of isolated pulses on the muon and electron lines, which are uncorrelated with each other.

Although frequent changes from positive to negative muons normalize away most systematic errors which exist *a priori*, there remain several effects which must be considered. The capture of negative muons is per-

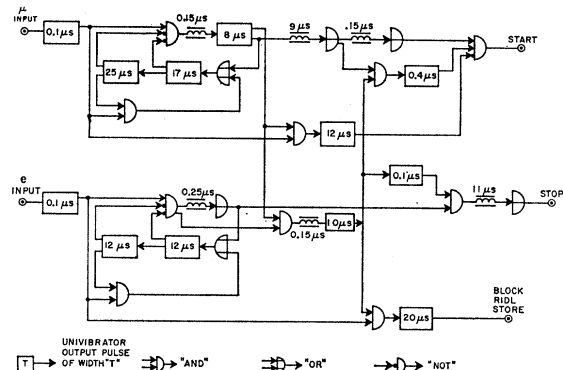

FIG. 2. Block logic of the interference-remover and gating circuitry.

haps the most obvious effect. Capture in high Z (wall) material is characterized by short lifetimes. Thus, it is only necessary to wait a few channels to eliminate the effect of high Z capture. The target was constructed exclusively of high Z material (zirconium and stainless steel) for this very reason. The possible capture in low Z matter is another question important in this context and, of course, also in the muon capture rate measurement. The purity of the hydrogen used in the target was held to better than 1 part in 10^9 and less than 1 ppm of deuterium. To reduce carbon contamination, the counter immediately before the target was only 0.020 in. thick. The anticounters were put in direct anticoincidence with the beam to preclude stoppings in the scintillator and were constructed with thin wrappings. As a result, the number of electrons from muon stoppings in carbon was completely negligible. The effect of the $\pi^+ \rightarrow \mu^+ + \nu$ decay was removed from the positive data, again, by the simple expedient of deleting a few early channels from the analysis. Another effect which one must consider is the difference in polarization of the μ^- and μ^+ , the μ^- being completely depolarized in liquid hydrogen.¹⁰ However, the use of stopped pions as a source of μ^+ , the geometry of the detector situation, and the small ambient field remaining in the iron shielding house, ensured that this effect was negligible for the positive data.

A systematic effect which must always be considered in this type of measurement is the possibility of rate dependence. Direct-current coupled logic circuitry was employed exclusively in efforts to preclude this type of dependence. Tests with random pulses derived from radioactive sources at various counting rates were taken at the same low rate of approximately 500 muon stops/sec. Confusion elimination resulted in the blocking of about 8% of the muon pulses. The electron detection efficiency was $\sim 15\%$. Data taking proceeded at about 250 000 events/h.

In the case of the positive runs, pions were stopped and it was feasible to vary the rate although, again, most of the data were taken at low rate, comparable to that of the negative muons. Some remarks on possible rate dependence in muon lifetime measurements are deferred to an Appendix. A plot of the data versus rate is shown in Fig. 3 and is consistent with a horizontal straight line.

III. ANALYSIS

The raw data for this measurement consisted of the numbers of counts stored in each of the 400 channels of the RIDL analyzer memory. Output was via Hewlett-Packard parallel printer and Tally paper tape punch. The punched paper tape was converted to punch cards using the IBM 1620 computer at the Nevis Laboratories. As a running check during the experiment, the life-

¹⁰ A. Ignatenko, L. B. Egorov, B. Khalupa, and D. Chultem, Zh. Eksperim. i Teor. Fiz. 35, 894 (1958) [translation: Soviet Phys.—JETP 8, 621 (1959)].

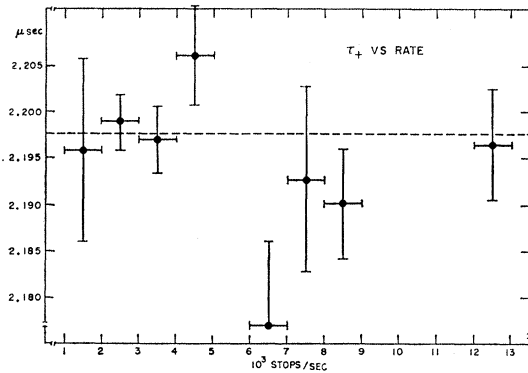

FIG. 3. Plot of the values of the lifetimes of positive muons versus pion stop rate.

times were quickly determined by a maximum likelihood method similar to that of Peierls.¹¹ This procedure used the following equation:

$$\frac{\Delta}{2} \coth\left(\frac{\Delta}{2\tau}\right) = \bar{t} + \frac{T}{e^{T/\tau} - 1},$$

where Δ is the channel width; T is the maximum time interval observed; $\bar{t} = \sum n_k(k - \frac{1}{2})\Delta / \sum n_k$, \bar{t} represents the "average" time; n_k is the number of counts in the k th channel. It is sufficient to treat the channels as rectangular and centered at the midpoints. The best fit value τ was determined numerically for each run using the 1620. The values so obtained were in good agreement with those from the more comprehensive final analysis. The final analysis involved fitting the raw data to a function of the form

$$Ne^{-T/\tau} + B$$

using the χ^2 procedure. This analysis was done using the IBM 7090 of the Columbia University Computing Center. The constant background resulted from the absence of beam structure and the logic of the interference remover circuitry. B was of the order of a fraction of a tenth percent of the peak channel count. A sample of the raw data is shown in Fig. 4. The time interval recorded covered approximately three muon lifetimes after time zero and about one-half lifetime before time zero.

As a check on the stability of the system, frequent alternations of cyclotron and magnet polarities were made so that positive and negative runs were made in close time proximity and under essentially the same conditions. It is thus reasonable to group our results according to these alternations. A plot of the results is presented in Fig. 5. Time proceeds from left to right—the first negative run was followed by the first positive run and so on.

A summary of the analysis for the 86 runs represented by the plot in Fig. 5 is presented in Table I. The errors

¹¹ R. E. Peierls, Proc. Roy. Soc. (London) A149, 467 (1935).

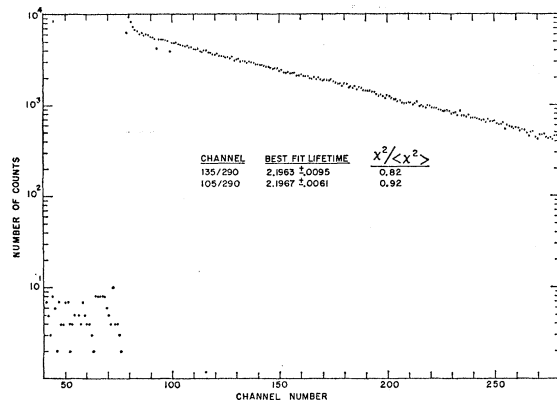

FIG. 4. Sample data. Note the presence of two "bad" channels near channel 100. These result from digital arithmetic errors. They were searched for in the analysis program and rejected. Typically 1 or 2 channels per run were so rejected and careful study indicates that the possible bias resulting from this sort of rejection is negligible. The effect of muon capture in iron can be seen in the early channels.

indicated are statistical only, as obtained from the χ^2 analysis for the individual runs. χ^2 for the best fit value of the negative muon lifetime is approximately at the 3% level. This is not alarming especially since most of the fluctuation can be traced to one grouping—4—, so the bulk of the data is not at all suspect.

The results for the ratio of positive and negative lifetimes are summarized in Table II. Since the uncertainty in the capture correction contributes very little to the error in the ratio one can, without loss of precision, take the individual ratios of corresponding negative and positive groups with the correction included. *A priori*, one would expect the individual ratios to compensate for any drifts, electronic or otherwise. It is obvious that one sees no difference between the results of the individual ratios and that for the over-all ratio of the net lifetimes.

IV. RESULTS

A. This Experiment

The results are as follows:

$$R = \tau_{\mu^-} / \tau_{\mu^+} = 1.000 \pm 0.001,$$

$$\tau_{\mu^+} = 2.197 \pm 0.002 \text{ } \mu\text{sec},$$

$$\tau_{\mu^-} = 2.198 \pm 0.002 \text{ } \mu\text{sec}.$$

The negative lifetime has been corrected for the capture rate from the $p\mu p$ molecule ($\Lambda_{p\mu p}$). As noted earlier the ratio should be particularly insensitive to systematic errors.

B. Previous Experiments

Although μ^- , μ^+ lifetime comparisons have been made in some light elements,¹² there are essentially no results on the free μ^- lifetime and on the ratio.

¹² M. Eckhause, Carnegie Institute of Technology Report NYO 9286 (February 1962).

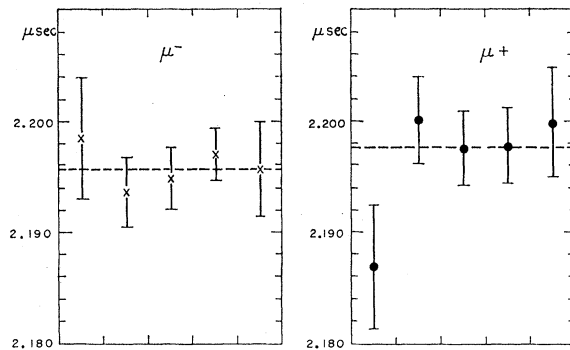

FIG. 5. Plot of the negative muon lifetimes and the positive muon lifetimes obtained in this measurement.

The μ^+ lifetime measurements, current as of September 1961, have been summarized by Lundy.¹³ Due to the improvements in technique, especially the use of digitron-type instruments and interference remover logic to eliminate time-dependent background, the measurements prior to Lundy's are perhaps not directly comparable to the latest results. The most recent measurements of τ_{μ^+} known to the authors are listed in Table III. There is good agreement among the various experiments.

Combining our value with those of the two experiments^{12,13} which have been published in detail, yields with good consistency $2.200 \pm 0.0015 \text{ } \mu\text{sec}$.

C. Theoretical Relationships

The ideas of a universal Fermi interaction and a conserved vector current enable one to compare the coupling constant in muon decay with that in a pure Fermi transition such as O^{14} beta decay. The basic relations are

$$f_l G_V^2 = \pi^3 \hbar^7 \ln 2 / m_e^5 c^4$$

in a pure Fermi beta decay, and

$$\tau_{\mu} G_{\mu}^2 = 192 \pi^3 \hbar^7 / m_{\mu}^5 c^4$$

in muon decay.

The most current value for the $O^{14} \rightarrow N^{14*}$ transition is¹⁴

$$f_l = 3066 \pm 10 \text{ sec}.$$

When Coulomb corrections are included the result is

$$G_V = 1.4145 \pm 0.0022 \times 10^{-49} \text{ erg cm}^3.$$

Before this value for the coupling constant can be used to predict a value for the muon lifetime, radiative corrections to both the muon decay and the O^{14} decay must be made. If one includes the radiative corrections due to Kinoshita and Sirlin,¹⁵ the predicted

¹³ R. A. Lundy, Phys. Rev. **125**, 1686 (1962).

¹⁴ R. K. Bardin, C. A. Barnes, W. A. Fowler and P. A. Seeger, Phys. Rev. **127**, 583 (1962).

¹⁵ T. Kinoshita and A. Sirlin, Phys. Rev. **113**, 1652 (1959).

value becomes

$$\tau_\mu = (2.286 \pm 0.008) \mu\text{sec.}$$

In this case, the radiative corrections to the muon decay are finite while those to the nuclear beta decay diverge and must be treated with a cutoff at the nucleon mass.

If one assumes the existence of a vector boson to mediate the weak interactions,¹⁶ the prediction of the muon lifetime from the measurements on O^{14} , including radiative corrections, has been calculated¹⁷

$$\tau_\mu = 2.286 \left\{ 1 - \frac{3}{5} \left(\frac{m_\mu}{m_W} \right)^2 + \frac{3\alpha}{\pi} \ln \frac{m_W}{m_N} \right\} \mu\text{sec.},$$

where m_W is the mass of the boson; m_N is the nucleon

TABLE I. Summary of runs.

Group	No. of runs	Mean lifetime ^a	Statistical error	Variance	χ^2
1-	5	2.1982	0.0053	0.0055	4.35
2-	10	2.1936	0.0031	0.0028	7.12
3-	18	2.1948	0.0026	0.0030	22.85
4-	18	2.1970	0.0022	0.0035	41.48
5-	7	2.1956	0.0042	0.0033	3.76
Total	58	2.1957	0.0014	0.0016	80.67
1+	3	2.1868	0.0055	0.0053	1.86
2+	6	2.1998	0.0037	0.0034	4.17
3+	7	2.1974	0.0032	0.0023	2.95
4+	5	2.1976	0.0034	0.0023	1.84
5+	4	2.1997	0.0046	0.0038	2.07
Total	25	2.1972	0.0017	0.0015	17.32

^a In units of μsec . Uncorrected for hydrogen capture.

TABLE II. Lifetime ratios.^a

<i>Individual Ratios</i>	
1-/1+	$= 1.0061 \pm 0.0035$
2-/2+	$= 0.9981 \pm 0.0022$
3-/3+	$= 0.9997 \pm 0.0019$
4-/4+	$= 1.0006 \pm 0.0018$
5-/5+	$= 0.9990 \pm 0.0028$
Weighted average:	1.0001
Statistical error:	± 0.0010
Variance:	± 0.0010
Chi-square:	4.04
<i>Over-all lifetime ratio</i>	
Negative lifetime/positive lifetime	$= 1.0005 \pm 0.0011$
Net result: Ratio	$= 1.000 \pm 0.001$

^a Capture correction of $\Lambda_{\tau\mu\mu} = 464 \pm 42 \text{ sec}^{-1}$ has been included.

¹⁶ M. Goldberger, *Proceedings of the Tenth Annual International Rochester Conference on High Energy Physics, 1960* (Interscience Publishers, Inc., New York, 1960), p. 732; S. Oneda and J. Pati, *Phys. Rev. Letters* 2, 125 (1959); T. D. Lee and C. N. Yang, *Phys. Rev.* 119, 1410 (1960).

¹⁷ T. D. Lee, *Phys. Rev.* 128, 899 (1962).

TABLE III. Recent measurements of τ_μ^+ .

Group	Lifetime (μsec)
Chicago ^a	2.203 ± 0.002
Carnegie ^b	2.202 ± 0.004
CERN ^c	2.198 ± 0.001
This experiment	2.197 ± 0.002

^a See Ref. 13. This paper actually quotes 2.203 ± 0.004 but to 98% confidence.

^b Reference 12.

^c Reference 1, p. 417.

mass; e.g., if $m_W \approx m_k$, $\tau_\mu \approx 2.220 \mu\text{sec}$. A recent theory due to Feinberg and Pais¹⁸ would further decrease τ_μ due to m_W but the radiative effects have not yet been calculated.

Differences of opinion exist concerning the nuclear physics situation in O^{14} . Recent work¹⁹ has indicated that configuration mixing in the O^{14} case may cause the Fermi matrix element to differ from $\sqrt{2}$ by an amount sufficient to account for differences between G_V and G_μ of as much as 1%.

D. Lifetime Ratio

As a search for breakdown in CPT invariance, we have established the equality of positive and negative muon lifetimes to within 0.1%. It seems possible to improve this by not more than a factor of 10. It should perhaps be reemphasized that CPT invariance is sufficient but not necessary for the equality of particle-antiparticle lifetimes. Inequality of lifetimes would show that neither CP nor CPT invariance holds in weak interactions. Should such an inequality be found, T invariance could be tested in muon decay by a search for transverse e polarization. The equality of the lifetimes found, however, implies only that either CP or CPT holds (or both). Other work in this laboratory²⁰ has established the equality of magnetic moments of positive and negative muons to 3 parts in 10^4 . However, the technique used yields deviations which can inevitably be blamed on environmental effects. Clearly, improvements here lie in carrying out a "g-2" measurement for negative muons.

ACKNOWLEDGMENTS

The authors wish to express their appreciation to the entire staff of the Nevis Laboratories whose constant cooperation made this experiment possible. We especially wish to thank Dr. Daniel Tycko and Mr. Donald Burd of Nevis whose help was indispensable in the data reduction and analysis.

¹⁸ G. Feinberg (private communication).

¹⁹ H. A. Weidenmuller, *Phys. Rev.* 127, 537 (1962).

²⁰ J. Menes, Columbia University Nevis Rept. 101 (1962).

APPENDIX

Test for Rate Dependence

The data of the present measurement are plotted versus π^+ stopping rate in Fig. 3. For convenience in display, all runs falling in a given range of abscissa have been statistically weighted and assigned to the center of the interval. A straight-line fit (to the actual data rather than the lumped data mentioned) has been made using,

$$T = aR + T_0,$$

where R is the instantaneous stopping rate in $10^8/\text{sec}$; T_0 is the intercept at zero rate. The results of this calculation are,

$$a = -0.00068 \pm 0.00057$$

$$T_0 = 2.2003 \pm 0.0031.$$

It is interesting to note that if one applies this test to the Chicago data,¹³ one obtains

$$a = +0.00125 \pm 0.00038,$$

$$T_0 = 2.1991 \pm 0.0015.$$

Proton-Proton Bremsstrahlung and the Off-Energy-Shell Behavior of the p - p Interaction*

M. I. SOBEL

Harvard University, Cambridge, Massachusetts

AND

A. H. CROMER

Northeastern University, Boston, Massachusetts

(Received 29 March 1963; revised manuscript received 24 July 1963)

The cross section for proton-proton bremsstrahlung at 160-MeV incident energy is calculated using the Yale and the Brueckner-Gammel-Thaler phenomenological nucleon-nucleon potentials. The cross section depends strongly on the off-energy-shell behavior of the T matrix for these potentials. Results for these two potentials differ by a factor of two to three, indicating that bremsstrahlung experiments should be able to distinguish between them.

I. INTRODUCTION

IN recent years extensive experimental effort has gone into obtaining precise measurements of the high-energy proton-proton differential cross section, polarization, and triple scattering parameters, and a number of phenomenological potentials have been found to fit these data.¹ However, scattering experiments of this kind can only determine the asymptotic behavior of the p - p wave function and hence only the behavior of the p - p interaction on the energy shell. Thus different phenomenological potentials which are equally successful in fitting the p - p scattering data can be expected to give quite different results for processes which depend on their off-energy-shell behavior.

The nuclear matter problem is an important example of a problem which requires knowledge of the nucleon-nucleon interaction off the energy shell. Using various phenomenological potentials, Brueckner and Masterson²

obtained quite different values for the binding energy and equilibrium density of nuclear matter, depending on the potential used. This work shows that we are still far from a complete determination of the nucleon-nucleon interaction.

For such a determination it will probably be necessary to investigate more closely those simple processes in which off-energy-shell effects are expected to be important. Everett^{3,4} has studied off-energy-shell effects in inelastic quasifree proton-deuteron scattering. However just at the quasifree peak the kinematics are such as to minimize the amount of energy nonconservation in the scattering matrix.⁵ Thus he found the effect was small and essentially masked by uncertainties in the calculation of multiple scattering effects.

The natural process to investigate for off-energy-shell effects is nucleon-nucleon bremsstrahlung, since multiple scattering corrections are expected to be small compared to off-energy-shell effects. In this paper calculations are made of the p - p bremsstrahlung cross section using two of the potentials studied by Brueckner

* Partially supported by grants from the National Science Foundation and the U. S. Army Research Office, Durham, North Carolina.

¹ B. P. Nigam, *Rev. Mod. Phys.* **35**, 117 (1963). This is the most recent review article on the status of the nucleon-nucleon interaction and references to the literature can be found here.

² K. A. Brueckner and K. S. Masterson, Jr., *Phys. Rev.* **128**, 2267 (1962).

³ A. Everett, Ph.D. thesis, Harvard University, 1960 (unpublished).

⁴ A. Everett, *Phys. Rev.* **126**, 831 (1962).

⁵ A. Cromer, *Phys. Rev.* **129**, 1680 (1963).