

Measurements of the First Townsend Ionization Coefficient in Neon and Hydrogen

LORNE M. CHANIN AND G. D. RORK

Honeywell Research Center, Hopkins, Minnesota

(Received 20 June 1963; revised manuscript received 14 August 1963)

Measurements have been made of the electron-ionization coefficient α/p_0 in neon and in hydrogen over an extended range of E/p_0 . In neon the present results at low E/p_0 are in agreement with the values previously obtained by Kruithof and Penning. In hydrogen for E/p_0 values less than those corresponding to the Paschen minimum, the present results are in agreement with those of Rose and other previous investigators. From measurements of the variation of α/p_0 as a function of the electron-collision number, information has been obtained concerning whether or not the electrons are in equilibrium with the applied electric fields.

I. INTRODUCTION

THE present investigation was initiated in an attempt to obtain measurements of the electron-ionization coefficient¹ α for various concentrations of hydrogen in neon. Prior to investigating these mixtures studies were conducted in pure neon and hydrogen. The purpose of the present article is to report the findings of these studies; the mixture measurements will be reported at some future date. According to the theory developed by Townsend² and subsequent workers, the growth of prebreakdown currents in uniform electric fields as the result of ionization by electron impact and secondary electron production is given by

$$\frac{I(x)}{I(0)} = \frac{\exp \alpha(x-x_0)}{1 - \gamma \{ \exp [\alpha(x-x_0)] - 1 \}} \quad (1)$$

for $x \geq x_0$.

Here x is the electrode separation, x_0 is related to the minimum distance the electron swarm must traverse to attain an equilibrium energy characteristic of the applied E/p_0 (electric field to pressure ratio, $p_0 = 273 p/T$). $I(0)$ is a small initial photoelectron current (externally generated) and γ is a generalized coefficient referring to electron production due to secondary processes. Equation (1) is often expressed in terms of the efficiency function η used by Penning and co-workers³⁻⁵ where $\eta = \alpha/E$ and x_0 is replaced by the corresponding quantity V_0 .

Several assumptions are involved in the derivation of the above expression. The applied electric field is assumed to be uniform; if the field is nonuniform the exponential terms must be replaced by integrals over the appropriate limits of x . In addition, it is assumed that the electron-energy distribution is in equilibrium with the field (for distances greater than x_0). Clearly for the case of high E/p_0 at low pressures (where most

high E/p_0 measurements are performed) if the number of electron collisions is not sufficiently great, the electrons will not reach equilibrium. Equation (1) also assumes that space charge effects are absent; this assumption requires that $I(0)$ be maintained small $< 10^{-9}$ A/cm². Moreover, electron losses by diffusion and attachment processes are assumed negligible, and finally α/p_0 and γ are assumed constant for a given E/p_0 .

For any particular value of E/p_0 a plot of $\ln I$ as a function of either electrode separation x or applied voltage V is initially linear. Thus, in the linear range measurements of the current as a function of x while maintaining E/p_0 constant, providing that γ is sufficiently small, yield the appropriate values of α/p_0 . In practice this method has been frequently used to determine ionization coefficients. Eventually, as the voltage or distance is increased to sufficiently high values, the γ term in the denominator becomes large giving rise to an up-curving in the $\ln I$ versus V curve and finally results in gas breakdown. In addition to measuring α/p_0 from the slope of the linear portion of $\ln I$ versus V curves, Townsend⁶ has shown that by measuring three currents I_1 , I_2 , and I_3 , corresponding to distances x_1 , x_2 , x_3 such that $x_1 < x_2 < x_3$, α/p_0 may be determined without any assumptions concerning x_0 , I_0 , or γ . This method has been used by Kruithof and Penning³ for the case of $x_2 - x_1 = x_3 - x_2 = b$, for which they have shown that α/p_0 can be evaluated from the expression

$$\exp \alpha b = I_3/I_1(I_2 - I_1/I_3 - I_2). \quad (2)$$

The determination of the other three unknowns [γ , x_0 , $I(0)$] in Eq. (1) involves an assumption concerning the value of one of them.

In recent years several articles^{7,8} in this field have indicated that, while the initial portion of the $\ln I$ versus x curve may appear linear, contributions from the secondary coefficient γ cannot be ignored. The method then used to evaluate α/p_0 is similar to that used by Kruithof and Penning. In the present studies α/p_0 was

¹ An excellent summary of work in this field is given in L. B. Loeb, *Basic Processes of Gaseous Electronics* (University of California Press, Berkeley, 1955), Chap. 8.

² J. S. Townsend, *Electricity in Gases* (Oxford University Press, London and New York, 1915).

³ A. A. Kruithof and F. M. Penning, *Physica* **3**, 515 (1936).

⁴ A. A. Kruithof and F. M. Penning, *Physica* **4**, 430 (1937).

⁵ M. J. Druyvesteyn and F. M. Penning, *Rev. Mod. Phys.* **12**, 87 (1940).

⁶ J. S. Townsend and S. P. MacCallum, *Phil. Mag.* **6**, 857 (1928).

⁷ E. Jones and F. Llewellyn Jones, *Proc. Phys. Soc. (London)* **72**, 363 (1958).

⁸ D. E. Davies and J. G. C. Milne, *Brit. J. Appl. Phys.* **10**, 301 (1959).

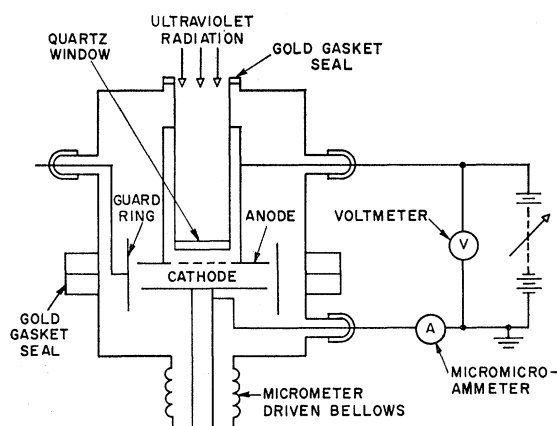

Fig. 1. Schematic diagram of the experimental tube and part of the associated circuitry.

evaluated in what appeared to be a linear portion of the curves both by the two- and three-point methods. In addition the values thus obtained were compared with those calculated using the three-point method applied to an obviously nonlinear portion of the curve, and finally with values calculated over the entire range of x used in a particular $\ln I$ versus x measurement.

In performing measurements of this type one of the more difficult problems is that of determining the approximate value of x_0 or V_0 . This difficulty arises from the fact that in order to solve for x_0 , γ , or $I(0)$, assumptions must be made concerning the value of at least one of them. Kruithof and Penning assumed that $x_0 = \text{I.P.}/E$, where I.P. corresponds to the ionization potential. Using a method of successive approximations more accurate values of x_0 or V_0 were then evaluated from a knowledge of the values of the other variables. Jones and Llewellyn Jones⁷ and Davies and Milne⁸ have determined values of x_0 assuming values of $I(0)$ as estimated from their $\ln I$ versus x curves. More recently Davies *et al.*⁹ have used a criterion developed by Gosseries¹⁰ to determine the values of x such that $x > x_0$. This criterion involves plotting $I(x)^{-1}$ as a function of $I(x + \Delta x)^{-1}$ for constant values of Δx . Departures from linearity at small x are then interpreted as either due to nonuniform fields or values of x such as $x < x_0$. It should be noted that Gosseries' method tends to weight variations of I for small x more strongly than at large x as a result of this method of plotting the data. In the present work, estimates of x_0 values assuming values of $I(0)$ using equations given by either Kruithof and Penning, Jones and Llewellyn Jones, or Davies and Milne were found to vary considerably, presumably due to uncertainties of the values of $I(0)$ and γ and thus were not considered reliable. In the present studies Gosseries type of plots were often used

as a guide to indicate the approximate x_0 or V_0 values. As discussed in Sec. III, a more reliable method of determining if the electrons are in equilibrium with the field involves calculations of α/p_0 as a function of the electron-collision number for a given $\ln I$ versus x curve.

In the present studies a number of $\ln I$ versus V curves were fitted using the corresponding values of α/p_0 and γ . This procedure was, however, not followed routinely principally because of large errors ($\sim 50\%$) associated with the determination of γ .

II. APPARATUS

Figure 1 shows a simplified drawing of the experimental tube and the electrical connections. The tube was constructed of stainless steel No. 304 and has two demountable gold gasket flanges to facilitate cleaning and assembly operations. The anode consists of an 8-cm diam nickel disk with a 2-cm diam center portion removed. A fine nickel mesh (100 lines/in.) was nickel brazed to the anode surface—resulting in an approximate 70% transparency. The cathode consisted of an 8-cm diam polished nickel plate. The edges of both electrodes were carefully finished to avoid edge effects. In the initial measurements a guard ring electrode was used to determine the importance of any such effects; in every case they were found to be of no significance. The anode-cathode separation was varied by means of a micrometer-driven bellows assembly which maintained the electrodes parallel to each other and permitted a variation of x from 0–2.5 cm with an accuracy of 10^{-3} cm. Following a given set of measurements the tube was routinely demounted and carefully examined for distortion of the anode-grid surface due to high-temperature bakeout. In all cases such distortion was found to be negligible. Ultraviolet radiation was introduced into the tube through an ultra-pure silica quartz window which was demountable from the tube by means of a gold wire gasket seal. A high-pressure mercury vapor lamp (100-W Osram) was used to provide a steady source of ultraviolet, constant to within 2%. Typical photoelectric currents were approximately 10^{-10} A. Reduction of the light intensity by a factor of approximately 50 had no detectable effect on the measured values of α/p_0 . From measurements of the photoelectric current in vacuum as a function of anode potential, contact potentials were measured and found to be approximately 0.5 V. For most of the measurements this amounts to less than a 1% correction. In addition to adequate shielding of the leads external to the tube, precautions were taken to eliminate the possibility of undesired electrical breakdown within the tube. Voltages applied to the tube were obtained from a battery supply. The voltages were measured using a Sensitive Research precision voltmeter with an accuracy of 0.25%. Currents were read with an accuracy of 2% using a Keithley model 400 micro-microammeter.

The gas handling system on which the tube was

⁹ D. Kenneth Davies, F. Llewellyn Jones, and C. G. Morgan, Proc. Phys. Soc. (London) **80**, 898 (1962).

¹⁰ A. Gosseries, Physica **6**, 458 (1939).

mounted was of the Alpert type¹¹ and used Granville-Phillips bakeable valves and capacitance manometer. Figure 2 shows a schematic drawing of the vacuum system. Following bakeout at temperatures of approximately 400°C for 15 h, the system attained pressures of roughly 10⁻⁹ Torr with rates of rise of contamination pressure on the order of 10⁻¹⁰ Torr/min. The gas samples used in these studies were either Airco or Linde Reagent grade gases. In view of the serious effects which minor impurity concentrations can have on measurements of this type, an attempt was made to insure that the measurements were performed on gas samples as relatively free from contamination as possible. The procedure finally adopted consisted of the combined use of liquid nitrogen traps and cataphoretic cleaning.^{12,13} Thus, the gases were first cataphoretically cleaned for at least 24 h at currents >50 mA at high pressures, then introduced through the liquid nitrogen trap into the tube. The cataphoresis discharge was maintained during the measurements. For the case of neon, evidence was obtained which clearly indicated the removal of impurities upon extending cleaning. Thus, at low E/p where α/p_0 is most sensitive to impurities and in general increased in their presence, cleaning had the effect of reducing α/p_0 . It has previously been observed¹⁴ that cleaning procedures have little effect on α/p_0 values measured in hydrogen. In the present studies in hydrogen no definite evidence was obtained that either liquid nitrogen trapping or cataphoretic gas purification had an influence on the measured values of α/p_0 .

III. MEASUREMENTS IN NEON

Figure 3 shows several examples of current versus voltage measurements obtained in neon. In those

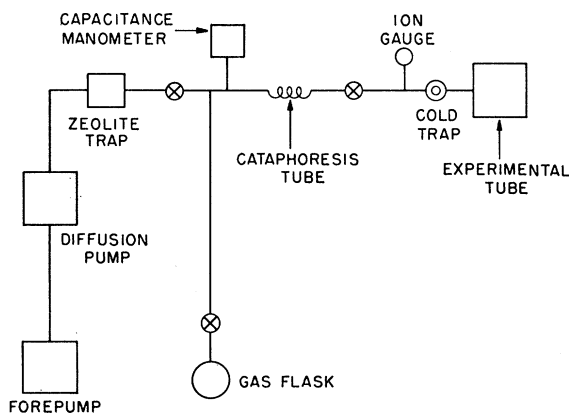

FIG. 2. Schematic drawing of the high-vacuum gas-handling system.

¹¹ D. Alpert, *Handbuch der Physik*, edited by S. Flügge (Springer-Verlag, Berlin, 1957), Vol. 12.

¹² R. Riesz and G. H. Dieke, *J. Appl. Phys.* **25**, 196 (1954).

¹³ A. L. Schmeltekopf, Jr., Doctorial dissertation, University of Texas, Austin, Texas, 1962 (unpublished).

¹⁴ A very complete survey of early studies in hydrogen is given by D. J. Rose, *Phys. Rev.* **104**, 273 (1956).

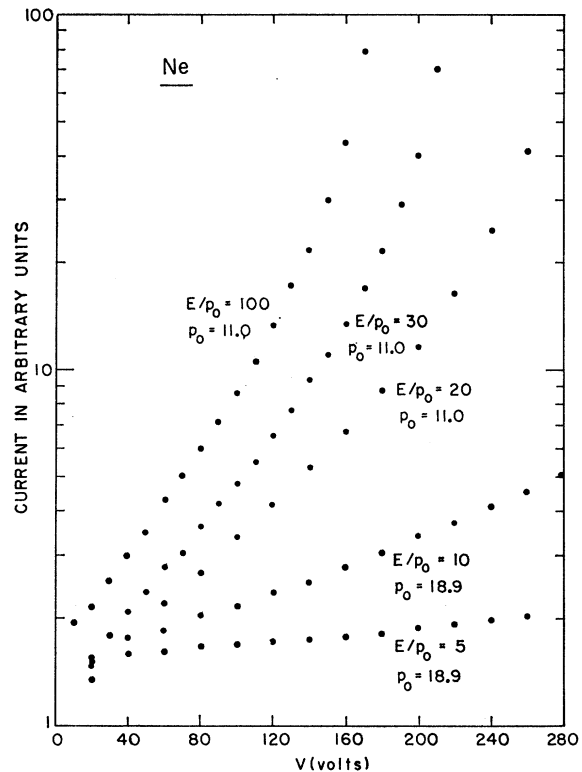

FIG. 3. Examples of measurements in neon of the current as a function of voltage for various E/p_0 values.

instances where possible the data were extended out to potentials close to the breakdown potential, thus permitting comparison of α/p_0 values from various portions of the $\ln I$ versus V curves. The measurements were restricted to current values less than 10⁻⁸ A in order to prevent serious alteration of the cathode surface due to ion bombardment and minimize space-charge effects. At low E/p_0 values, the initial current values were observed to decrease with increasing V presumably due to back diffusion effects; in addition a step-like behavior⁴ corresponding to the onset of ionization was also observed.

For each $\ln I$ versus V plot α/p_0 was calculated in the apparently linear region both by the two-point slope method and by the three-point method given by Eq. (1). Moreover a comparison was made of the α/p_0 values calculated by applying the three-point method to various regions of the $\ln I$ versus V curves. Comparison of results in the linear range showed that, in general, α/p_0 values calculated using the two-point slope method were higher than those calculated using the three-point method. The difference can be accounted for by the failure of the two-point method to take into account the secondary-emission coefficient.

For $E/p_0 < 10$ V/cm \times Torr, since the differences in current values are very small, the normal three-point method leads to considerable errors. Under these conditions it has been shown by Kruthof and Penning³

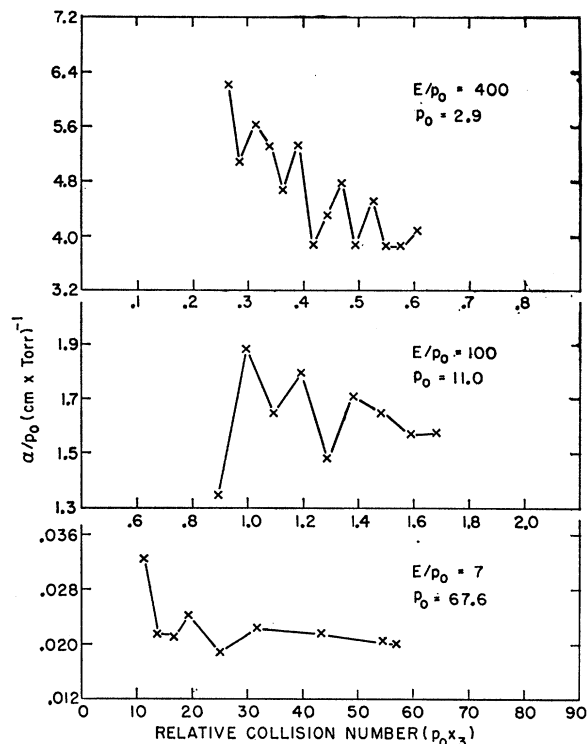

FIG. 4. The variation of α/p_0 in neon with the relative collision number p_0x_3 .

that Eq. (1) reduces to

$$d \ln I(x)/dx = \alpha(1+\gamma). \quad (3)$$

In the present studies this method was used to evaluate α/p_0 for $E/p_0 < 10$ V/cm \times Torr. The values of γ which were used¹⁵ were extrapolations of values calculated at high E/p_0 using formula given by Davies and Milne. In general, the correction for the effect of γ was $\sim 10\%$.

For $E/p_0 > 20$, the α/p_0 values calculated using the three-point analysis applied to the curved regions were always smaller than those calculated from the linear regions. This difference could not be accounted for by a failure to take into account secondary-emission coefficients since the three-point analysis does not require a knowledge of γ in computing α/p_0 . Moreover, since values of Δx in the comparison were chosen equivalent, the discrepancy could not be accounted for on the basis that Δx values in the linear range were too small. In order to further investigate the difference in α/p_0 values deduced from different portions of the curve, calculations were made of the variation of α/p_0 for a

¹⁵ Using the formula given by Davies and Milne in Ref. 8, calculations were also made both for x_0 and γ values for a number of $\ln I$ versus V curves. In these calculations it is necessary to assume values of $I(0)$; these were estimated from the current-voltage measurements assuming no back diffusion. Typical values of γ computed by this method were on the order of 0.07. In every case experimental points used to determine γ were taken at distances greater than the x_0 values calculated using Davies and Milne's formula.

given $\ln I$ versus V curve as a function of the relative number of collisions which the electrons undergo in passing from the cathode to the anode. Figure 4 shows a plot of α/p_0 as a function of relative collision number¹⁶ for several values of E/p_0 . From Fig. 4 it will be noted that for $E/p_0 = 7$, α/p_0 is relatively independent of the number of collisions once the electrons have undergone a sufficient number of them, thus indicating that the electrons are in equilibrium, i.e., $x > x_0$ and also that α/p_0 and γ are constant. For large values of $E/p_0 > 20$, however, it was observed that α/p_0 was a strong function of the collision number; thus α/p_0 had a damped type

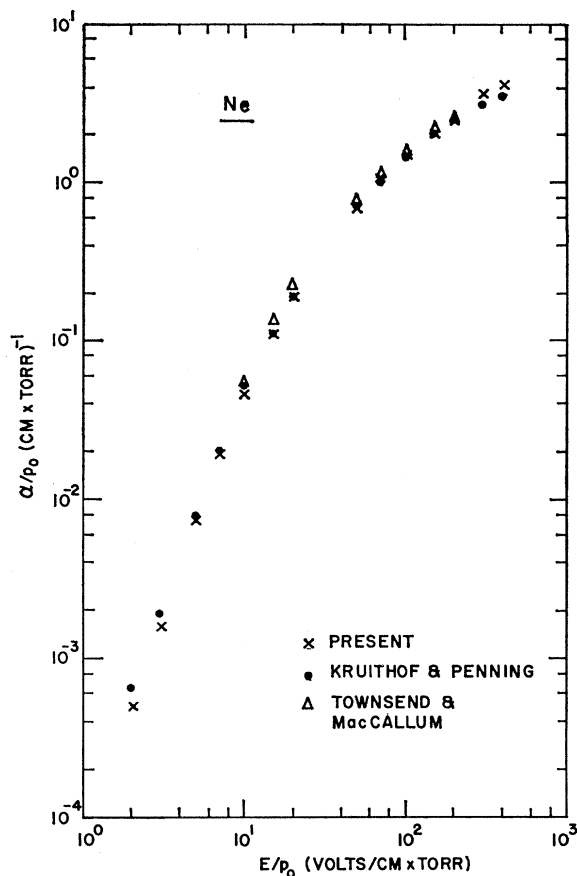

FIG. 5. The variation of α/p_0 with E/p_0 in neon. The present data for $E/p_0 < 100$ represent average values, under conditions such that the electrons are apparently in equilibrium. The data for $E/p_0 > 100$ are not believed significant due to nonequilibrium conditions.

¹⁶ The actual number of collisions made by the electrons in crossing the electrode separation x is equal to $v_c x / w_e$, where v_c is the collision frequency and w_e is the electron-drift velocity. In the present discussion we are only interested in the general variation of α/p_0 with the relative collision number p_0x where the value of x was chosen to be x_3 in the three-point analysis. The determination of the actual collision number at high E/p_0 is made difficult due to a lack of basic data. For the case of neon approximate values of the maximum number of actual collisions for the cases shown in Fig. 4 for $E/p_0 = 7, 100,$ and 400 are $4000, 30,$ and 7 , respectively.

of oscillatory behavior such that in the limit of sufficient collisions the α/p_0 value for a given collision number approaches a final equilibrium value. This behavior is exhibited in Fig. 4 for the case of $E/p_0=100$. For $E/p_0=400$, as shown in Fig. 4, not only does α/p_0 have a strong oscillatory behavior, but also as the collision number increases, the average value of α/p_0 decreases. The origin of the oscillatory variation may result from a changing or fluctuating electron-energy distribution. Such a variation has previously been observed by Kruithof and Penning at low E/p_0 values for the case of neon-argon mixtures. The marked decrease (55%) in α/p_0 with collision number as shown for $E/p_0=400$ in Fig. 4 is interpreted as being due to the electrons not having achieved equilibrium with the applied electric field. It is clear that in evaluating α/p_0 as a function of relative collision number in this manner, by necessity, Δx values must be chosen to be relatively small with the result that errors in determining α/p_0 are greater than the normal 5% error. Thus, in the present studies, such measurements are used only to determine the qualitative variation of α/p_0 with collision number, that is, as a test as to whether or not the electrons are in equilibrium with the applied electric field. From the behavior at $E/p_0=400$ it seems apparent that the electrons are not in equilibrium; there is, however, some indication that for the maximum collision number equilibrium conditions may be approached. It is clear that different sets of experimental data will give the same values of α/p_0 if the analyses are conducted out to approximately the breakdown potential, since, regardless of the pressure at which the measurements are made, the p_0x product will be the same in all cases. Thus, even though there is good agreement between the α/p_0 values of various workers, if the electrons are not in equilibrium the data are not meaningful.

The decrease in the value of α/p_0 with increasing collision number at high E/p_0 values may be explained by considering that the energy gain per mean free path may be comparable to, or larger than the average

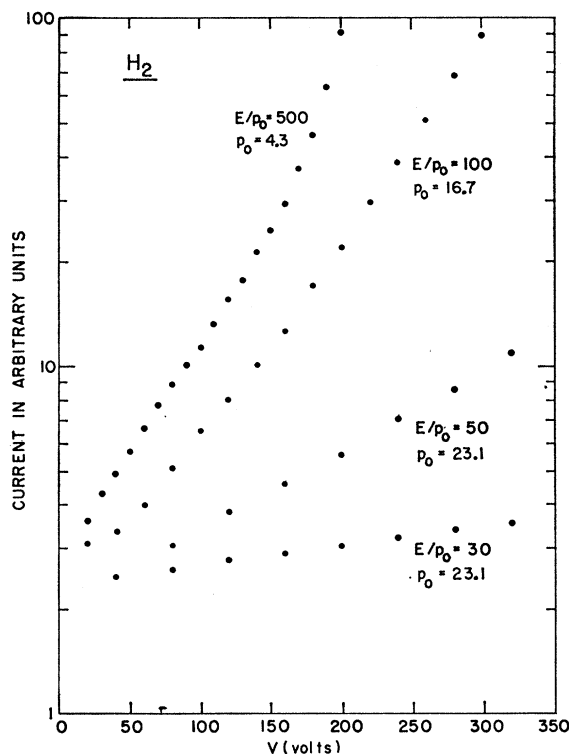

Fig. 6. Examples of measurements in hydrogen of the current as a function of voltage for various E/p_0 values.

electron energy. Hence, with increasing number of collisions, the average electron energy increases and since the probability of ionization decreases with increasing electron energy at these values of E/p_0 , α/p_0 will consequently decrease. This type of anomalous behavior has previously been predicted by Loeb.¹ In the present studies a number of measurements were made in different gas samples at different pressures for a fixed E/p_0 . In each case, calculations of α/p_0 versus collision number reproduced the general oscillatory behavior within the experimental error. From a series of plots similar to those shown in Fig. 4 it was concluded that, for values of $E/p_0 > 100$, the electrons were not in equilibrium with the applied electric field.

Figure 5 shows a plot of α/p_0 as a function of E/p_0 ; the average values of Kruithof and Penning⁴ and those of Townsend and MacCallum⁶ are shown for comparison with the present results.¹⁷ The present values shown in Fig. 5 for $E/p_0 < 100$ represent average values of α/p_0 for many measurements at various pressures and under conditions such that the collision number is sufficient so that the electrons are apparently in equilibrium. In addition, x_1 in the three-point analysis was selected to

¹⁷ The values of α/p_0 attributed to Townsend and MacCallum were prepared from their table of α/p versus E/p by assuming a reference temperature of 300°K. An α/p_0 versus E/p_0 curve was drawn through points thus obtained and comparison values taken from the curve.

TABLE I. Ionization coefficient α/p_0 ($\text{cm} \times \text{Torr}$)⁻¹ versus E/p_0 ($\text{V}/\text{cm} \times \text{Torr}$) in neon.

E/p_0	Present pressure range	α/p_0		
		Present	Kruithof and Penning	Townsend and MacCallum
2	52.4 to 68.5	0.0005	0.00066	...
3	52.4 to 68.5	0.00154	0.00192	...
5	10.5 to 68.5	0.00726	0.00800	...
7	10.5 to 68.5	0.0196	0.0204	...
10	9.1 to 68.5	0.0462	0.0501	0.054
15	9.1 to 43.2	0.113	0.116	0.136
20	4.25 to 43.2	0.198	0.192	0.228
50	1.59 to 43.2	0.680	0.715	0.785
70	1.59 to 30.0	1.03	1.04	1.13
100	1.25 to 21.2	1.53	1.49	1.58
150	1.25 to 21.2	2.16	2.11	2.15
200	1.25 to 13.5	2.62	2.60	2.60
300	1.25 to 13.5	3.60	3.22	...
400	1.25 to 10.6	4.12	3.56	...

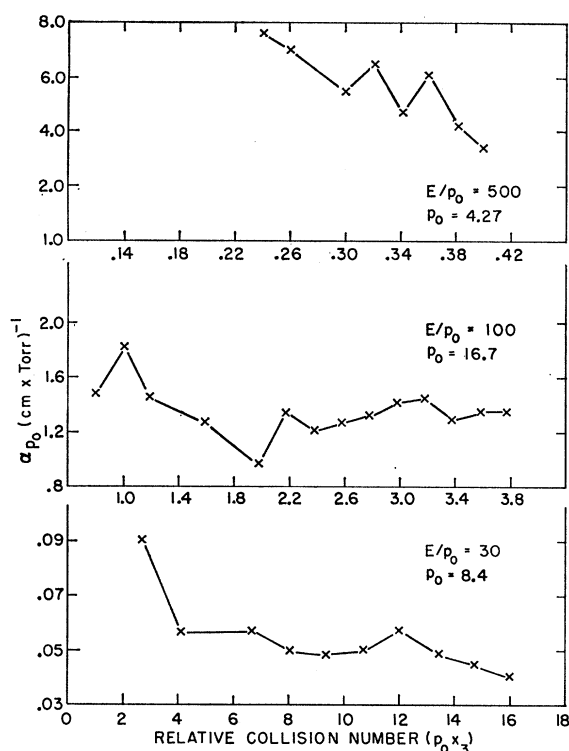

FIG. 7. The variation of α/p_0 in hydrogen with the relative collision number $p_0 x_3$.

be greater than x_0 which was inferred from Gosseries' plots and the value of Δx was chosen to be as large as possible to minimize errors in α/p_0 . For $E/p_0 > 100$ the electrons are not believed to be in equilibrium; thus the significance of the corresponding α/p_0 values is questionable. The data shown in Fig. 5 are given in tabular form in Table I. Also given in Table I is the range of pressures studied in the present work for each value of E/p_0 .

From Fig. 5 it will be noted that at the lowest values of E/p_0 the present results lie below the corresponding results of Kruthof and Penning. At slightly higher values of E/p_0 , the α/p_0 values of Townsend and MacCallum are larger than those of either Kruthof and Penning or those of the present study.¹⁸ For low E/p_0 values, gas purity is of considerable importance, in particular when the gas is contaminated with small concentrations which form a Penning mixture with the main gas.^{19,20} Since, at higher E/p_0 values, the Penning

¹⁸ The neon used by Townsend and MacCallum was subjected to a high-frequency discharge as a means of removing impurities. There is reason to believe, however, that their neon was contaminated; thus their data at very low E/p_0 (not shown in Fig. 5), which they believed questionable, lie considerably above the present results and has the typical α/p_0 behavior of a contaminated gas.

¹⁹ Recent measurements by Davies and Milne (Ref. 8) in neon in which small amounts of argon were suspected are in serious disagreement with present values.

²⁰ Purification procedures for the neon used by Kruthof and Penning included subjecting the gas to a form of cathaphoretic cleaning (2-5 mA for 1 h).

effect becomes negligible, the agreement at high E/p_0 between the various sets of data may be understood.

It has previously been noted⁵ that for E/p_0 values in excess of the Paschen minimum (in neon for $E/p_0 > 100$) measured values of α/p_0 tend to lose their significance. Considering that for the case of $E/p_0 > 100$ measurements at pressures ~ 1 Torr are made under conditions such that the number of electron collisions in crossing the electrode gap is extremely small,¹⁶ the nonequilibrium behavior as evidenced in Fig. 4 for the case of $E/p_0 = 400$ may be easily understood. Under these conditions the character of this type of measurement changes from that of a swarm to roughly a beam type of measurement.

IV. MEASUREMENTS IN HYDROGEN

Typical current versus voltage measurements in hydrogen are shown in Fig. 6. As in the case of neon, α/p_0 was calculated using both two- and three-point methods in the linear range and in addition three-point analysis was also used to determine α/p_0 in the nonlinear region.²¹ In the linear range both methods gave the same average values. Moreover, with the exception of high $E/p_0 > 100$, values obtained in the nonlinear portion

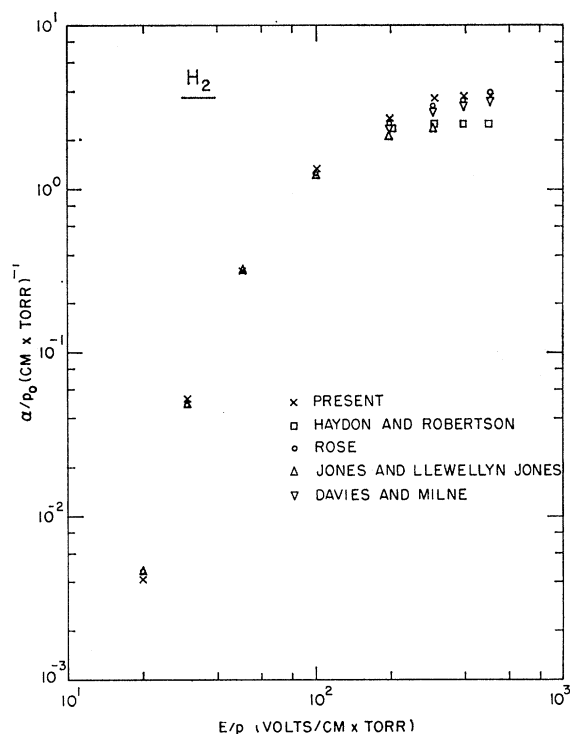

FIG. 8. The variation of α/p_0 with E/p_0 in hydrogen. The present data for $E/p_0 < 150$ represent average values, under conditions such that the electrons are apparently in equilibrium. The data for $E/p_0 > 150$ are not believed significant due to nonequilibrium conditions.

²¹ Calculations of γ and x_0 were also made for a number of measurements in hydrogen. In general the calculated γ values were smaller than in neon.

TABLE II. Ionization coefficient α/p_0 (cm \times Torr)⁻¹ versus E/p_0 (V/cm \times Torr) in hydrogen.

E/p_0	Present pressure range	α/p_0				
		Present	Rose	Jones and Llewellyn Jones	Davies and Milne	Haydon and Robertson
20	4.27 to 23.1	0.0041	0.0046	0.0046
30	4.27 to 23.1	0.051	0.0495	0.0495
50	1.02 to 23.1	0.310	0.315	0.315	0.317	0.315
100	1.02 to 16.7	1.29	1.26	1.25	1.26	1.25
200	1.02 to 16.7	2.64	2.55	2.12	2.38	2.38
300	1.02 to 16.7	3.57	3.21	2.40	2.97	2.55
400	1.02 to 8.85	3.7	3.6	...	3.22	2.55
500	1.02 to 6.15	3.7	3.9	...	3.46	2.55

were in agreement with those measured in the linear range.

The agreement at low E/p_0 values between the two- and three-point methods is in accordance with the fact that in hydrogen, γ at these energies is relatively small. As in the neon studies, α/p_0 was calculated for a given $\ln I$ versus V curve as a function of the relative number of collisions²² which the electrons undergo in passing from cathode to anode. Figure 7 shows the variation of α/p_0 for several values of E/p_0 . As for the case of neon it will be noted that at low E/p_0 , α/p_0 does not exhibit a pronounced variation with collision number once the electrons have undergone a sufficient number of collisions. For moderate E/p_0 values, however, α/p_0 is observed to have an oscillatory behavior, while for $E/p_0=500$, α/p_0 exhibits a strong decrease (90%) with increasing collision number. From a number of plots similar to those shown in Fig. 7 we conclude that in hydrogen the electrons are not in equilibrium with the field for $E/p_0 > 150$.

Figure 8 shows a plot of the average values of α/p_0 as determined in the present studies. For comparison with the present values, the average values of Rose, Jones and Llewellyn Jones, Davies and Milne, and Haydon and Robertson^{23,24} are also given. The data shown in Fig. 8 are given in tabular form in Table II, together with the pressure range investigated for each E/p_0 value in the present studies. It will be noted that for E/p_0 values up to 100 the present results are in good agreement with the results of previous investigators.

In the present studies, both at high and low E/p_0 evidence was obtained which substantiated evidence obtained earlier^{14,25} that (α/p_0) determinations in

hydrogen are rather insensitive to impurities. Thus, in the present work, both cataphoretic cleaning and liquid nitrogen trapping had no observable effect on measured α/p_0 values. It is thus highly improbable that discrepancies at high E/p_0 can be accounted for on the basis of impurities. It has previously been indicated⁷ that differences between the data of Rose and Jones and Llewellyn Jones at high E/p_0 may be accounted for by the failure to take into proper account secondary emission. From the present studies the relatively good agreement between the present data and that obtained by Rose suggests that the discrepancy may not be accounted for in this manner, since the present analysis includes the secondary emission while Rose's measurements did not. The present measurements indicate that at high E/p_0 values the electrons are not in equilibrium with the field and since α/p_0 is a strong function of the collision number, differences in values can be accounted for on this basis.

V. CONCLUSIONS

The present measurements show that from studies of the ionization coefficient as a function of collision number, information can be obtained concerning whether or not the electrons are in equilibrium with the applied field. It has been found that agreement of results between various investigators at high E/p_0 may be understood; however, that the data are not generally meaningful is a result of nonequilibrium conditions. The general variation of α/p_0 with collision number observed in neon and hydrogen has also been recently observed by the authors for the case of helium.

ACKNOWLEDGMENTS

The authors wish to thank Dr. H. J. Oskam of the Plasma Physics group at the University of Minnesota for his interest and the benefit derived from many helpful discussions concerning this work. In addition, they are also indebted to various members of the Physical Electronics Section of the Honeywell Research Center for their interest and assistance in this study.

²² For the case of $E/p_0=30, 100, 500$ in hydrogen, the approximate values of the maximum number of actual collisions are 8000, 80, 10, respectively.

²³ S. C. Haydon and A. G. Robertson, Proc. Phys. Soc. (London) **78**, 92 (1961).

²⁴ The values of α/p_0 attributed to Jones and Llewellyn Jones and Haydon and Robertson were inferred from curves passing through their data points.

²⁵ H. A. Blevin, S. C. Haydon, and J. M. Somerville, Nature **179**, 38 (1957). The α/p_0 values reported in this study cover an E/p_0 range from 20-190. These measurements which are in agreement with Rose's data were performed on hydrogen believed to be seriously contaminated with impurities.