

Decay of Sc⁴⁸

MANNY HILLMAN*

Brookhaven National Laboratory, Upton, New York

(Received 16 October 1962)

A previously unreported gamma ray of approximately 175 keV and 7% abundance was found in the decay of Sc⁴⁸. This necessitates a revision of the decay scheme to include a second beta group with an end-point energy of approximately 475 keV. The presence of the new gamma and second beta group was confirmed by means of gamma-gamma and beta-gamma coincidence counting techniques.

THE decay of Sc⁴⁸ has been studied in numerous laboratories. The most recent of these studies was reported by Van Nooijen^{1,2} in which a summary of earlier work is given. Basically, the decay scheme of Sc⁴⁸ as reported is illustrated in Fig. 1. A single beta group with a 651-keV end-point energy is followed by three gamma rays (1.04, 1.30, and 0.98 MeV) in cascade. Apparently, however, the low-energy part of the gamma spectrum has not been investigated.¹⁻⁵

In the course of an investigation⁶ concerned with 14-MeV neutron cross-section measurements, the gamma spectrum of Sc⁴⁸ obtained from the V⁵¹(n,α)Sc⁴⁸ reaction was found to contain a peak in the 175 keV area (Fig. 2). That this gamma (of 7% abundance) belongs to the decay of Sc⁴⁸ was confirmed by the constancy of its specific activity during various chemical purification procedures, by the determination of its half-life and by the coincidence studies described in the following sections.

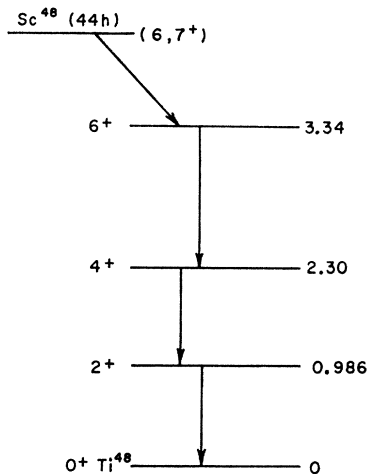

FIG. 1. Decay scheme of Sc⁴⁸.

* This work was performed under the auspices of the U. S. Atomic Energy Commission.

¹ B. Van Nooijen, Doctoral Dissertation, Technische Hogeschool Te Delft, Netherlands, 1948 (unpublished).

² B. Van Nooijen, J. Konijn, A. Heyligers, J. F. Van der Brugge, and A. H. Wapstra, *Physica* **23**, 753 (1957).

³ B. Hamermesh, V. Hummel, L. Goodman, and D. Engelkemeir, *Phys. Rev.* **87**, 528 (1952).

⁴ H. Casson, L. S. Goodman, and V. E. Krohn, *Phys. Rev.* **92**, 1517 (1953).

⁵ M. J. Sterk, A. H. Wapstra, and R. E. W. Kropveld, *Physica* **18**, 135 (1953).

⁶ M. Hillman, *Nucl. Phys.* **37**, 78 (1962).

PREPARATION OF SOURCES

Sources for gamma spectroscopy were prepared by the V⁵¹(n,α)Sc⁴⁸ reaction. Pure vanadium foils were irradiated with 14.5-MeV neutrons obtained from the BNL Van de Graaff generator using the T(d,n)He⁴ reaction. Sources obtained in this fashion were exceptionally pure radiochemically and were used directly.

For sources for beta spectrometry, the Sc⁴⁸ was prepared by the V⁵¹(n,α)Sc⁴⁸ reaction by irradiation of ~100 g of vanadium pentoxide. The oxide was dissolved in alkali. The mixture was acidified. Iron carrier was added and the mixture was rendered alkaline. The ferric hydroxide, which carried practically all of the Sc⁴⁸, was separated by centrifuging, and was cleaned of most of the occluded vanadate by dissolving in acid and reprecipitating with base several times. Most of the iron was then extracted into ether from a 6-8 N hydrochloric acid solution. A small amount of iron carrier was then added and the purification procedure was repeated. The aqueous solution was then brought to pH 3 and the scandium was extracted with a 0.5M solution of TTA (thenoyltrifluoroacetone) in benzene. The benzene solution was washed several times with water to remove all ammonium chloride and then extracted with 2N hydrochloric acid. The acid solution was washed several times with benzene to remove all TTA. The solution was evaporated to a very small volume and then to dryness on 0.25-mil Mylar treated with insulin. The source prepared in this way was very thin and virtually free from interfering solids. The source was grounded with Aquadag.

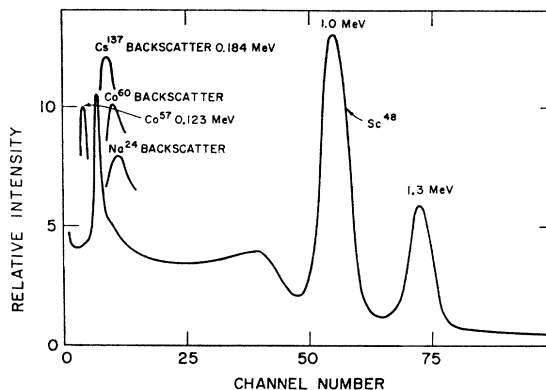

FIG. 2. Gamma spectrum of Sc⁴⁸.

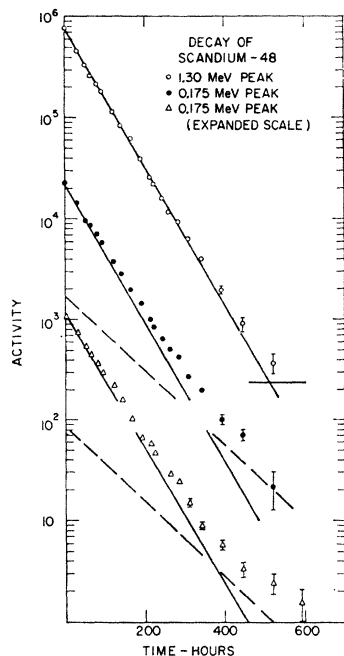

FIG. 3. Decay curves of photopeaks from the Sc^{48} gamma spectrum: (a) the 1.30-MeV photopeak —○, (b) the 0.175-MeV photopeak for one spectrometer gain setting —●, and (c) the 0.175-MeV photopeak for a higher gain setting (expanded scale) —△. Curves are displaced for clarity.

GAMMA SPECTRUM

The gamma rays were detected using a 3 in. \times 3 in. NaI(Tl) crystal for the higher energy gammas and both 3 in. \times 3 in. and 1.5 in. \times 1.5 in. NaI(Tl) crystals for the low-energy gamma. A sample spectrum is illustrated in Fig. 2. Featured are the 1.3-MeV photopeak, the unresolved doublet at 1.0 MeV which have been previously observed and interpreted, and their associated Compton distributions. The backscatter peak associated with the high-energy gammas here appears as a shoulder on the right slope of a sharp, previously unreported photopeak at ~ 175 keV. The backscatter peaks and photopeak of the other nuclides in the illustration were used to calibrate the energy of the new peak.

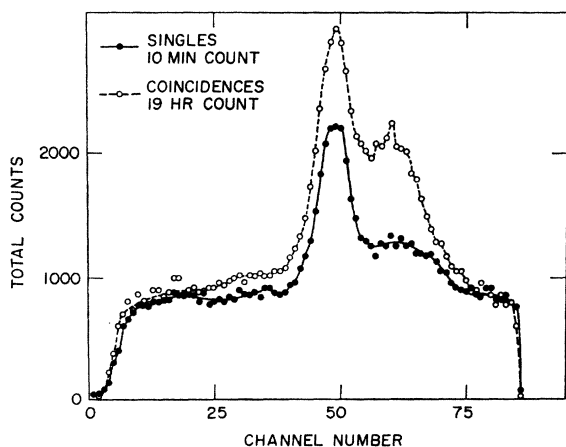

FIG. 4. Gamma spectra of Sc^{48} in the 175-keV area: (a) singles spectrum —●, and (b) spectrum in coincidence with 1.30-MeV gammas —○.

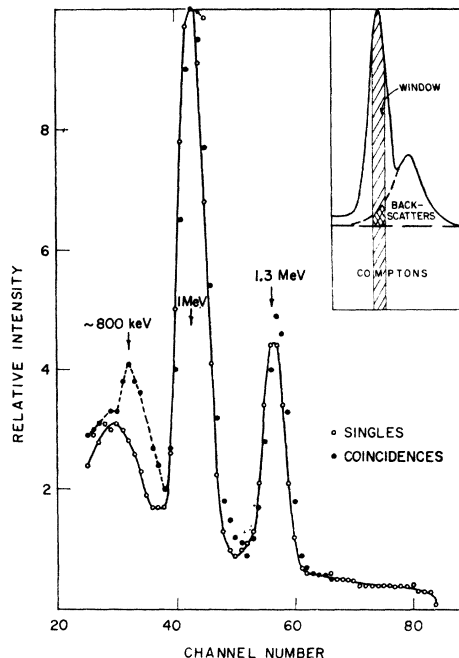

FIG. 5. Gamma spectra of Sc^{48} in the high energy area: (a) singles spectrum —○, and (b) spectrum in coincidence with 175-keV gammas. Window of gammas in 175-keV area used for coincidence experiment.

Originally this photopeak was considered to have arisen from the decay of Sc^{47} which may have been formed from the $\text{V}^{50}(n,\alpha)\text{Sc}^{47}$ reaction. However, to obtain the 160-keV gamma of Sc^{47} in such intensity requires the reaction to have an inordinately high cross section (~ 1.2 b). The formation of Sc^{47} from the $\text{V}^{51}(n,\alpha)\text{Sc}^{47}$ reaction had been considered energetically unlikely. Bormann⁷ and co-workers, however, in determining the excitation function of the $\text{V}^{51}(n,\alpha)\text{Sc}^{47}$ reaction, have measured the 160-keV peak (unresolvable from the 175-keV gamma of Sc^{48}) reporting a half-life of 82 h and a cross section for the reaction with 14-MeV neutrons of 3 ± 2 mb. This half-life determination was repeated. The decay of the peak was followed for about thirteen half-lives of Sc^{48} (seven of Sc^{47}) and compared with the decay of the 1.30-MeV peak (Fig. 3). By means of a least-squares analysis, the half-life of the 1.30-MeV peak, as expected, was found to be 44.1 ± 0.3 h. When analyzed as a two-component system with a half-life of the second component assigned as 3.4 days, the half-life of the 175-keV peak was found to be 43.9 ± 0.6 h for one spectrometer gain setting and 45.2 ± 1.5 h for a second gain setting. The second component was found to be present in $7.6 \pm 2.5\%$ and $7.9 \pm 1.1\%$ of the total, respectively. Certainly, at the initial time of counting, no more than 10% of the 175-keV gamma was due to the presence of Sc^{47} . These percentages are given as upper limits since there is no

⁷ M. Bormann, S. Cierjacks, R. Langkau, and H. Neuert, Z. Phys. 166, 477 (1962).

real assurance that a second component had a half-life of 3.4 days or that it was Sc^{47} if it did. Based on the above data, the cross section for the $V^{51}(n, n\alpha)Sc^{47}$ reaction is less than 0.3 mb. Thus, Sc^{47} was eliminated from consideration as the major source of the 175-keV gamma.

GAMMA-GAMMA COINCIDENCES

The low-energy gamma spectrum in coincidence with the 1.30-MeV photopeak is given in Fig. 4 along with the "singles" spectrum. Both consist of a 175-keV photopeak and of a backscatter peak and Compton distribution which were generated from higher energy gammas. The ratio of the photopeak height to the Compton distribution intensity is greater for the coincidence spectrum than for the "singles" spectrum. This is due to the fact that only the Comptons of the 1.0-MeV doublet are in coincidence with the 1.30-MeV photopeak. The relative intensity of the Comptons in the coincidence spectrum is thus expected to be reduced by one-third.

The data above demonstrate that the 175-keV gamma is in coincidence with the 1.30-MeV gamma. The data concerning the coincidences with the 0.98-1.04-MeV doublet, which is not illustrated since it is virtually identical to Fig. 4, demonstrates only that the 175-keV gamma is in coincidence but does not determine whether it is in coincidence with both gammas. The latter question is resolved by examination of the high-energy gammas in coincidence with the 175-keV gamma (Fig. 5). Since there is virtually no change in the relative peak heights of the (0.98-1.04)-MeV doublet and the 1.30-MeV gamma, the 175-keV gamma is in coincidence with both the 0.98- and the 1.04-MeV gammas.

A small additional peak at ~ 800 keV is in the coincidence spectrum. By means of ancillary experi-

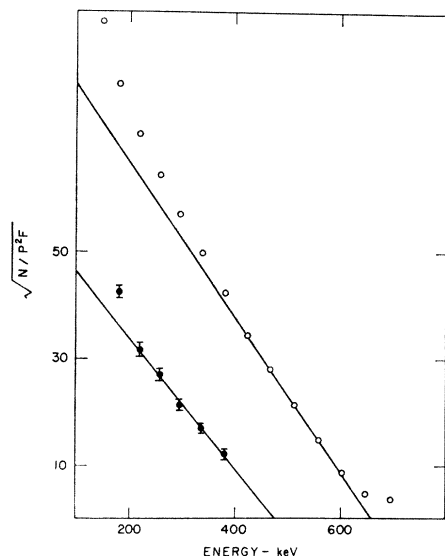

FIG. 6. Kurie plot of beta spectrum of Sc^{48} .

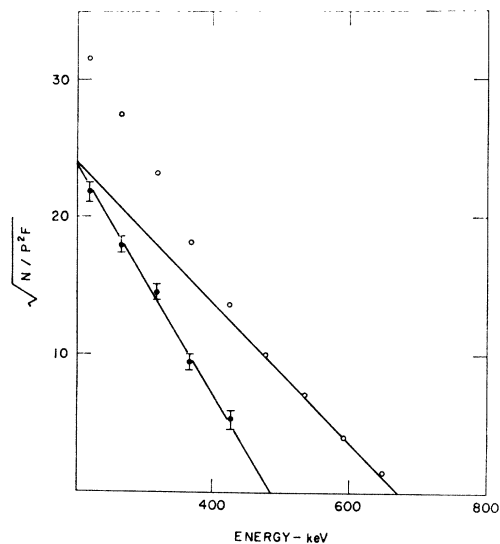

FIG. 7. Kurie plot of beta spectrum of Sc^{48} in coincidence with 175-keV gammas.

ments this was shown to be an intensified Compton edge caused by coincidences with a small part of the backscatters of the high-energy gammas which overlap the 175-keV peak. The intensification of the Compton edge is due to 100% angular correlation at 180° between the backscatters and the Compton edge.

BETA SPECTRUM AND BETA-GAMMA COINCIDENCES

The betas were detected and analyzed by an iron-free intermediate-image beta-ray spectrometer.⁸ In order to obtain maximum transmission the annulus was kept wide open, reducing the resolution, however, to 4%. The gammas were detected by a 6-mm-thick sodium iodide crystal coupled to a relatively noise-free photomultiplier tube through a light pipe (to remove the tube from the magnetic field). When desired, both

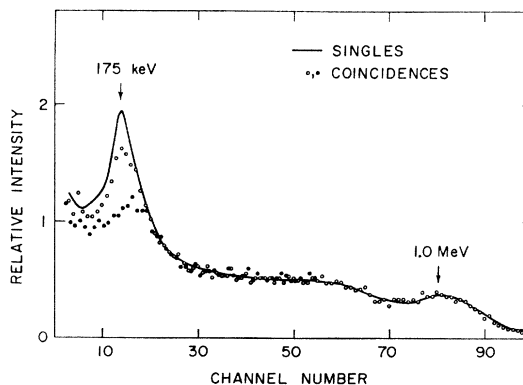
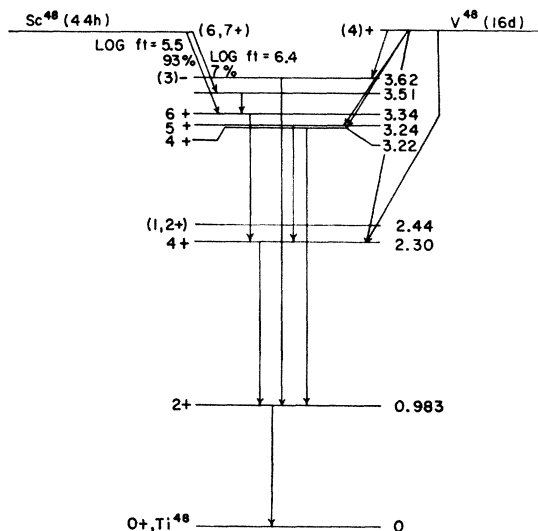

FIG. 8. Gamma spectra of Sc^{48} : (a) singles spectrum —, (b) spectrum in coincidence with 316 ± 13 keV electrons —○, and (c) spectrum in coincidence with 534 ± 21 keV electrons —●.

⁸ D. E. Alburger, Rev. Sci. Instr. 27, 991 (1956).

FIG. 9. Decay schemes of Sc^{48} and V^{48} .

signals were examined for coincidence. In this fashion were determined the "singles" beta spectrum (Fig. 6), the beta spectrum in coincidence with 175-keV gammas (Fig. 7), the gamma spectrum in coincidence with 316 ± 13 keV electrons from the beta spectrum (Fig. 8), and the gamma spectrum in coincidence with 534 ± 21 keV electrons (Fig. 8).

In contrast with the observations of Van Nooijen^{1,2} and co-workers, the "singles" beta spectrum (Fig. 6) was found to have two beta groups with end-point energies of 658 ± 26 and 475 ± 23 . There appear to be some anomalies at energies below 200 keV which may be due to sample thickness or noise. Van Nooijen's Sc^{48} source was said to contain some Sc^{47} as an impurity. When corrected for this impurity, which has two beta groups with end-point energies of 610 (26%) and 450 (74%) keV, his Kurie plot of the residue was found to be straight. However, the energies of the Sc^{47} betas are similar to those of Sc^{48} . Despite the absence of further details of the correction procedure, it might be reasonable to suspect that over-correction had caused the loss of the lower energy beta group of Sc^{48} which was observed in the present work. Furthermore, for this work, Sc^{47} is present as an impurity to the extent of less than 0.7%. Therefore, there is certainly no correction warranted.

Much firmer confirmation of the low-energy beta arises from the coincidence studies. The relative intensity of the low-energy beta is markedly increased in the

beta spectrum in coincidence with 175-keV gammas (Fig. 7). The high-energy betas are due to coincidences with Compton and backscatter radiation of the high-energy gammas. Since the 175-keV gammas are comparable in intensity to the Compton and backscatter radiation under the 175-keV peak, the relative beta intensities should also be comparable. In the coincidence spectrum, the low-energy beta intensity was found to be about 42% of the total. In the "singles" spectrum, the low-energy betas were found to be about 16% of the total, but anomalies observed in the lower energy points tend to render this latter result as too high. The relative intensities determined from the gamma spectrum is preferable.

Of interest in the gamma spectra in coincidence with different energy betas is the nature of the spectra in the 175-keV area (Fig. 8). Significantly, the 175-keV peak is missing in the gamma spectrum in coincidence with 534-keV betas while it is almost completely present in the spectrum in coincidence with 316-keV betas. These data again demonstrate that there are two betas, one in coincidence with a 175-keV gamma. Both betas are apparently in coincidence with the higher energy gammas.

CONCLUSIONS

The results presented in the preceding sections demonstrate that the decay scheme of Sc^{48} requires two beta groups, one followed by three gammas in cascade and the second followed by four gammas in cascade. This is illustrated in Fig. 9 along with the latest information⁹ on the decay of V^{48} . From the log ft value (6.4), the 475-keV beta transition may be allowed or first forbidden. The spin and parity of the Sc^{48} ground state have been reported as 6+ by Van Nooijen,¹ although this has been questioned.⁹ On this basis the spin of the 3.51-MeV level of Ti^{48} can be 5, 6, or 7+. A spin of 8+ is also possible. Insufficient data are available to improve this assignment.

ACKNOWLEDGMENTS

I am indebted to Dr. David E. Alburger for the use of the Van de Graaff and for aid in the beta spectrometry experiments, and to various members of the Nuclear Chemistry Group of BNL's Chemistry Department and to several members of the Hot Laboratory for valuable discussions. J. Daane and Miss J. Ford helped with some of the chemical separations.

⁹ R. A. Ristinen, A. A. Bartlett, and J. J. Kraushaar, *Bull. Am. Phys. Soc.* **7**, 341 (1962).