

in the double-scattering correction. The two different values for the uncertainty in the double-scattering correction were based on a feeling that the amount of this correction was most likely underestimated.

Theoretical curves calculated by Bjorklund and Fernbach¹⁵ are also presented in Fig. 5. The calculations are for an optical-model potential having a real central well with rounded edges and surface absorption and spin-orbit terms. These calculations give the shape-elastic scattering only and would be expected to give values lower than the experimental values which include the compound-elastic scattering. The slight energy difference between the theoretical and experimental curves should not significantly affect a comparison of the two.

The data points for indium could almost fit the theoretical curve within counting statistics except for the high side of the peak near $\cos\theta=1/2$, although the fit at the large angles would be marginal. The silver data do not show as good an agreement, being lower than the theoretical curve over a much larger range of

¹⁵ F. Bjorklund and S. Fernbach, University of California Radiation Laboratory Report, UCRL-4927-T, 1957 (unpublished); also Phys. Rev. **109**, 1295 (1958).

the whole curve. It is not likely that the difference in the agreement between silver and indium is due to experimental and calculational procedures since these were essentially identical for the two elements.

The theoretical fits were based upon a large variety of experimental data. The 7-MeV calculations were based in part upon data in which inelastically scattered neutrons with more than 80% of the energy of elastically scattered neutrons might have been counted. This could have resulted in an appreciably larger inelastic scattering contribution than in the case of the present experiment where the effective bias was set at about the 90% level.

ACKNOWLEDGMENTS

The authors wish to express thanks to Dr. R. O. Bondelid and Dr. E. A. Wolicki, who assisted in the early stages of the experiment; to Mrs. Josephine Eves, who transcribed the printed pulse-height data records onto punched-paper tape; to the staff of the NAREC for their suggestions on computer programming for the data treatment; and to S. Chappell, who checked some of the hand calculations.

Some Gamma-Ray Cascades in Rh¹⁰³, Ce¹⁴⁰, and Dy¹⁶⁰†

S. I. H. NAQVI* AND B. G. HOGG

Allen Physics Laboratory, The University of Manitoba, Winnipeg, Canada

(Received October 27, 1961; revised manuscript received June 20, 1962)

The 445–53 keV cascade in Rh¹⁰³ was found to have an intensity <0.5 relative to 1000 for the intensity of the most intense, 498-keV, gamma ray in the decay scheme. No evidence was found for a 323-keV gamma ray in this scheme. Spins of 5/2 for the 538-keV level and 7/2 for the 650-keV level in Rh¹⁰³ are assigned in keeping with the relative intensities of <0.5 and 4 for the 445- and 538-keV gamma rays, respectively. Cascades of 1088–814, 1415–487, and 1596–306 keV have been observed in Ce¹⁴⁰ and a level at 3498 keV introduced into the scheme. The beta feed to this level is estimated to be ~0.002% of the most intense beta group in the decay of La¹⁴⁰. Cascades of 87–1312 and 197–1200 have been observed in Dy¹⁶⁰ and a level at 1484 keV is introduced.

INTRODUCTION

MANY cases of nuclear de-excitation occur through a series of cascades to the ground state. The total energy involved in the various cascades between two given levels is, of course, the same.

A sum-coincidence spectrometer¹ is particularly useful in studying weak gamma-ray cascades, especially in cases where the decay is complex. The spectrum that one obtains for a two-gamma cascade is uncluttered by Compton edges and gamma rays from the other transi-

tions in the decay. The spectrum shows prominently only the sum peak and the two gamma rays of the cascade.

In these experiments sources of Ru¹⁰⁸, La¹⁴⁰, and Tb¹⁶⁰ of ~5 μ C strength each were used to investigate a number of cascades from excited states of Rh¹⁰³, Ce¹⁴⁰, and Dy¹⁶⁰, respectively.

APPARATUS AND METHOD²

A block diagram of the apparatus is shown in Fig. 1. The two NaI(Tl) detectors are Harshaw "Integral Line" detector type 6S4/2 (1.5- \times 1-in. crystal coupled to a 2-in. photomultiplier tube). Occasionally and with-

† Supported by the Defense Research Board of Canada and the National Research Council of Canada.

* Now at St. Paul's College, The University of Manitoba, Winnipeg, Canada.

¹ A. M. Hoogenboom, Nuclear Instr. **3**, 57 (1958).

² S. I. H. Naqvi, Nuclear Instr. (to be published).

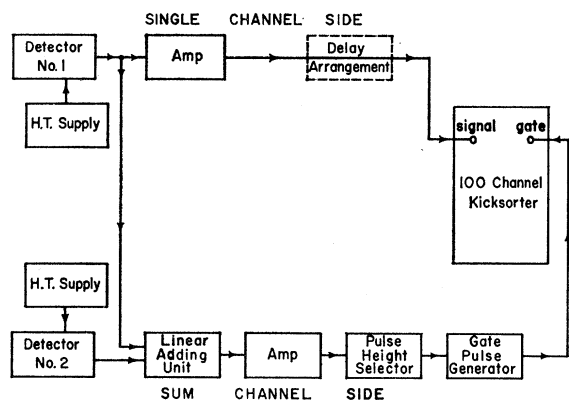
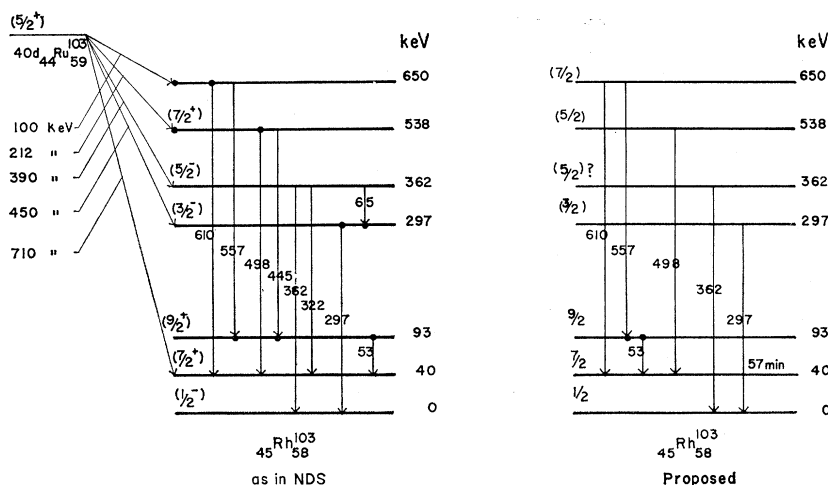

FIG. 1. Block diagram of the sum-coincidence spectrometer.

in a microsecond of each other, each detector receives and totally absorbs one of the gamma rays from the cascade. If the detectors are arranged to have the same energy calibration, the output from the linear summing unit will give a pulse corresponding to the total energy in the cascade. The single-channel pulse-height analyzer is used to select the pulses corresponding to the sum peak and pass a signal to the gate pulse generator which will allow the 100-channel kicksorter to view the pulses from the first detector and summing with other corresponding pulses from the second detector to give the total pulse height for the cascade are observed. The final display is a spectrum reduced to the sum peak and pairs of peaks which together sum to the sum peak.

To avoid the radiation scattered from one crystal reaching the other, no parts of the crystals were allowed to face each other directly. The angle between the crystals was selected so that there was maximum amount of lead between the detectors.

FIG. 2. The Rh^{103} decay scheme.

RHODIUM-103

An energy scheme for Rh^{103} constructed from previously available data³ is shown on the left-hand side of Fig. 2. In this decay scheme a 557–53 keV cascade in competition with a 610-keV crossover and a 445–53 keV cascade in competition with a 498-keV crossover gamma ray have been indicated to accommodate, mainly, Saraf's results.⁴

The existence of the 557–53 keV cascade was confirmed by setting a gate on the sum channel corresponding to 610 keV and observing the spectrum. This is shown by Fig. 3, curve B. A normal scintillation spectrum is also shown and labeled A. The appearance of peaks at 53 and 57 keV in the sum-coincident spectrum confirms the existence of this cascade and the large sum peak at 610 indicates that the crossover transition of 610 keV is more favored than the cascade transition. The peak at 498 keV is the chance peak from the very intense 498-keV gamma ray.

A similar search for the 445–53 keV cascade gave a negative result. Four experiments of 1000 min each were performed and we set an upper limit of 0.5 for the intensity of the cascade relative to an intensity of 1000 assigned to the 498-keV crossover.

A search for the 323-keV transition, previously reported,⁵ was made and not found.

For Rh^{103} various arguments, summarized by Singh,⁶ are in favor of spin 1/2 for the ground level, 7/2 for the 40-keV isomeric level, 9/2 for the 93-keV level, and 5/2 or 7/2 for the levels at 538 and 650 keV. The intensities of the 445- and 557-keV gamma rays relative to their crossovers as measured in the present investigation favor a spin of 5/2 for the 538-keV level and 7/2 for the 650-keV level. The NDS scheme gives a spin of 7/2 for the 538-keV level and leaves the 650-keV

³ *Nuclear Data Sheets*, National Academy of Sciences-National Research Council (U. S. Government Printing Office, Washington, D. C.). Henceforth denoted by NDS.

⁴ B. Saraf, *Phys. Rev.* **97**, 715 (1955).

⁵ H. H. Forster and A. Rosen, *Phys. Rev.* **98**, 1172 (1955); *Nuovo cimento* **1**, 972 (1955).

⁶ B. P. Singh, *Nuclear Phys.* **21**, 450 (1960).

level unassigned. This was done in the NDS, to include the results of Flack and Mason⁷ who measured the angular correlation of the 557-53 and 445-53 keV cascades following Saraf's report of the existence of these cascades in about equal intensity. Since then measurements on the same cascades have been reported by Singh⁶ and it is interesting to note that his experiments confirm the angular correlation results of Flack and Mason for the 557-53 keV cascade and do not confirm the angular correlation results for the 445-53 cascade. This discrepancy is removed if the 445-53 cascade is assumed not to exist, as indicated by our experiment, and the assumption is made that these previous experimenters were encountering difficulties in observing the weak 445-keV gamma ray because of the very intense neighboring 498-keV gamma ray.

Failure to observe the 322-keV gamma ray in the present investigation means that if its conversion line reported by Forster and Rosen⁵ is real, the transition is almost completely converted. This does not agree with the calculation of Sliv and Band,⁸ if the spin assignment of 5/2 for the 362-keV level given in the NDS is true.

CERIUM-140

The energy levels given in the NDS scheme are shown in Fig. 4 for Ce^{140} . There are a number of uncertain (dotted) levels because of the lack of β decay information.

A sum-coincidence spectrum set on the sum peak of 1902 keV is shown in Fig. 5. The spectrum has six peaks (aside from the sum peak) and indicates three cascades; 306-1596, 487-1415 and 814-1088 keV. A possible way of fitting these cascades, not inconsistent with the shell model, is to assume a level at 3498 keV above the ground state. These three cascades have been drawn on the

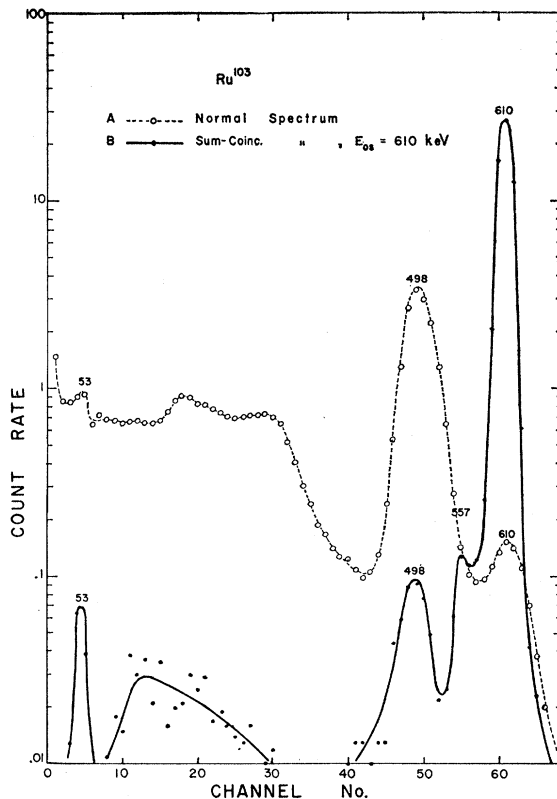

FIG. 3. The sum-coincidence spectrum observed when the gate is set on the 610-keV sum peak in Ru^{103} decay.

right-hand side of Fig. 4 between the proposed 3498-keV level and existing level at 1596 keV and involving intermediate levels at 2410, 2083, and 1902 keV.

From a total absorption spectrum of La^{140} performed

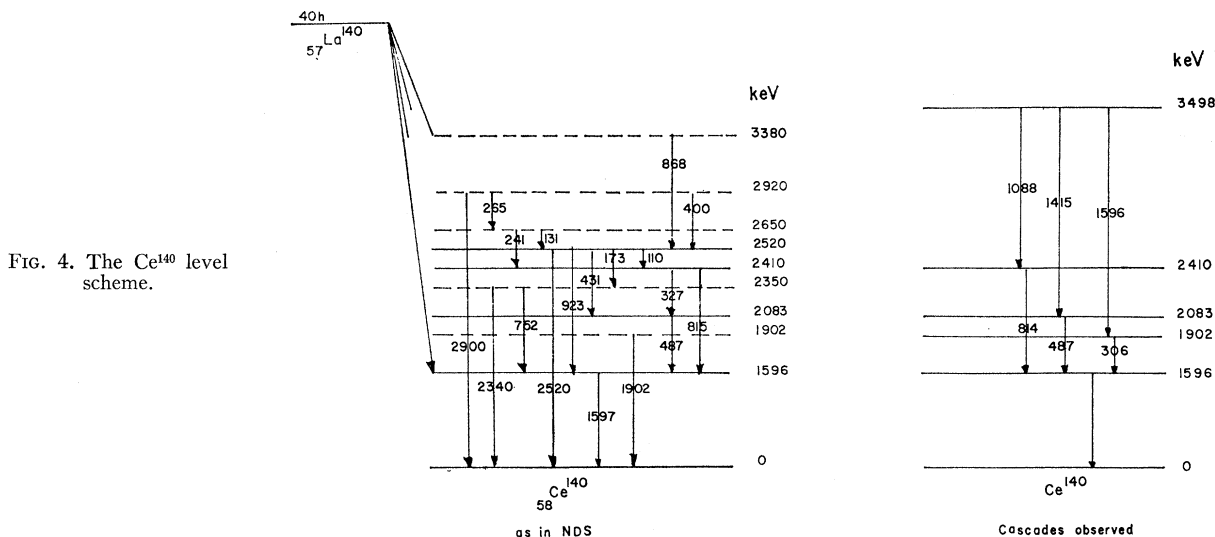

FIG. 4. The Ce^{140} level scheme.

⁷ F. C. Flack and P. Mason, Proc. Phys. Soc. (London) **71**, 247 (1958).

⁸ L. A. Sliv and I. M. Band, Leningrad Physico-Technical Institute Report, 1956 [translation: Report 57ICC, K 1, issued by Physics Department University of Illinois, Urbana, Illinois (unpublished)].

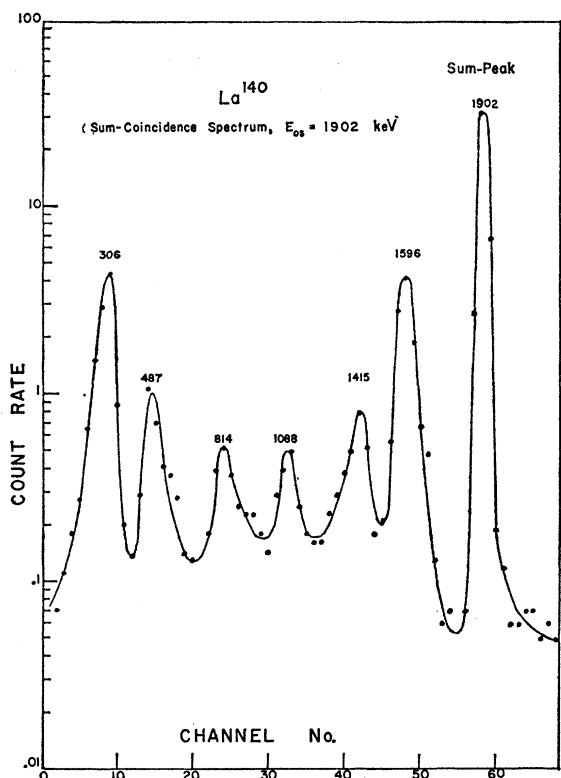

FIG. 5. The sum-coincidence spectrum observed when the gate is set on the 1902-keV sum peak in La^{140} decay.

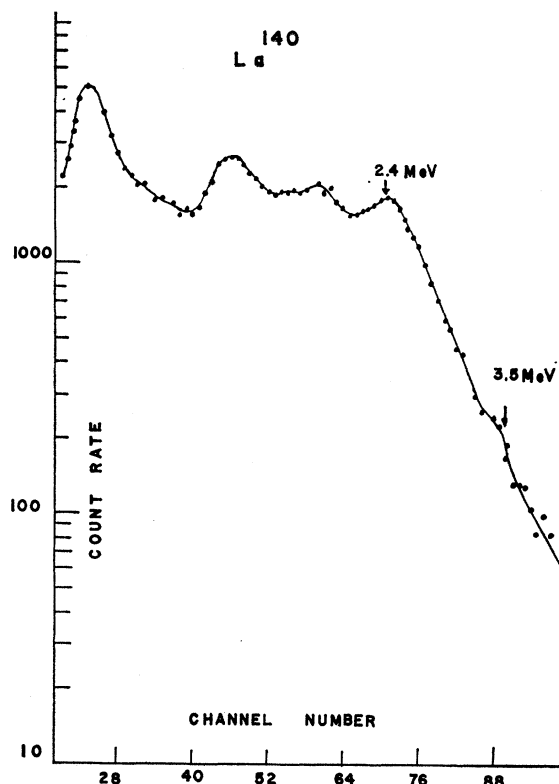

FIG. 6. The total absorption spectrum of La^{140} showing the high-energy region.

in a well type 4-in. \times 4-in. NaI crystal, shown in Fig. 6, a sum peak of 3.5 MeV of low intensity appears. An estimate of the beta feed to this level by a comparison

of the 3.5- and 2.4-MeV gamma intensities leads to an intensity of the predicted beta transition of $\sim 0.002\%$ of the most intense beta group.

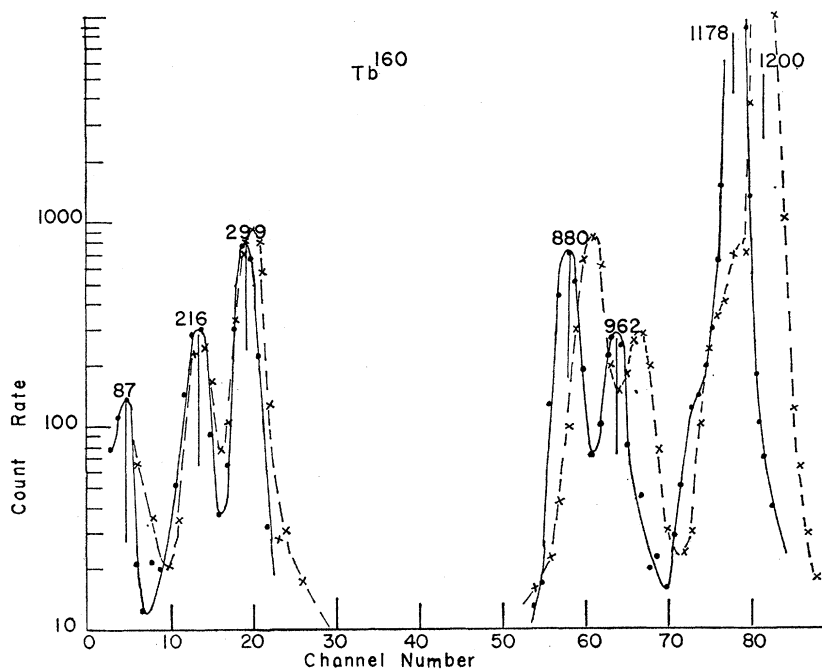
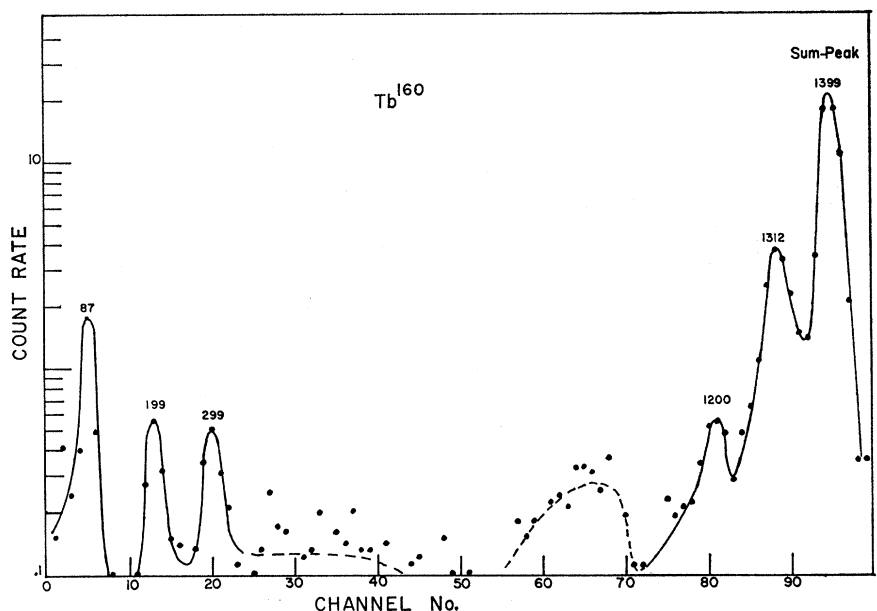

FIG. 7. The sum-coincidence spectra for Tb^{160} decay with the gate set at 1178 keV, full curve, and the gate set at 1200 keV, broken curve. The energies appearing above the peaks in the full curve are in keV and are noted by vertical lines.

FIG. 8. The sum-coincidence spectrum for Tb^{160} decay with the gate set at 1399 keV.



DYSPROSIUM-160

Possible levels in Dy^{160} at 87, 284, 966, 1048, 1200, 1265, 1358, and 1395 keV can be inferred from the combined investigations of Clark and Knowles,⁹ Nathan,¹⁰ and Bäckstrom *et al.*¹¹ Recently, on energy considerations, Ewan *et al.*¹² have suggested removal of the level at 1200 keV and inserted one at 1284 keV.

A sum coincidence spectrum with the gate set at 1200 keV is shown in Fig. 7 by the broken curve. Two cascades appear in this spectrum along with a chance line from the high-intensity 87-keV gamma ray. The same two cascades are moved to lower energies as shown in Fig. 7 by the full curve where the sum coincidence gate was set at 1178 keV. They correspond to transitions previously known between the 1265-966-87 keV levels

and the 1265-1048-87 keV levels. No information from this experiment would necessitate a level at 1200 keV.

Figure 8 is a sum coincidence spectrum with the gate set at 1399 keV. Two cascades, 87-1312 and 199-1200 keV appear together with a chance 299 and a considerable unresolved portion of low intensity between 299 and 1200 keV. The 87-1312 keV cascade easily fits into transitions between the levels 1399-87-0 keV. The 199-1200 keV cascade would seem to fit the transitions between the 1399-1200-0 keV levels, and thus would seem to support the postulation by Bäckstrom *et al.*¹¹ of a level at 1200 keV. Since, however, the existence of the 1200-keV level is in serious doubt¹² it is possible to postulate a level ~ 1200 keV above the 284-keV level at ~ 1484 keV. This would allow the observed cascade to come down from the 1484 to the 284 to the 87-keV level. The existence of the 197-keV gamma ray between 284- and 87-keV levels is well known. This postulated level at ~ 1484 keV could be one of a rotational band of which the 1399-keV (3-) level is also a member.

⁹ M. A. Clark and J. W. Knowles, *Bull. Am. Phys. Soc.* **2**, 231 (1957).

¹⁰ O. Nathan, *Nuclear Phys.* **4**, 125 (1957).

¹¹ G. Bäckstrom, J. Lindskog, O. Bergman, E. Bashandy, and A. Bäcklin, *Arkiv Fysik* **15**, 121 (1959).

¹² G. T. Ewan, R. L. Graham, and J. S. Geiger, *Nuclear Phys.* **22**, 610 (1961).