

at the excitation energy of this experiment, so the assumption $\Gamma_p \approx \Gamma_t$ is used.

ACKNOWLEDGMENTS

The authors wish to express their appreciation for the work of Dr. Kenneth Purser in the alpha-yield experi-

ment; the many helpful discussions with Professor Daniel Ling, Professor Ralph Krone, and Professor Frank Prosser; the help of Harlan Graber with computer work; and the assistance of Richard Moore and Denny Watson on all phases of the experiments.

4.48-MeV Level of $\text{Ca}^{40}\dagger^*$

R. D. BENT, D. E. BLATCHLEY, AND W. W. EIDSON
Indiana University, Bloomington, Indiana
 (Received May 14, 1962)

The reaction $\text{Ca}^{40}(\alpha, \alpha'\gamma)$ was studied using particle-gamma coincidence techniques and the 22-MeV alpha-particle beam from the Indiana University cyclotron. The 4.48-MeV level of Ca^{40} is observed to decay strongly to the 3.73-MeV 3^- level. An upper limit of 5% is placed on the intensity of the ground-state transition. The weakness of the ground-state transition is strong evidence against a 1^- assignment for the 4.48-MeV level. This result, together with other data, indicates that the 4.48-MeV level is 5^- .

I. INTRODUCTION

DURING the past few years several different spin and parity assignments have been made for the 4.48-MeV level of Ca^{40} . A 1^- assignment was suggested

by the $\text{Ca}^{40}(\alpha, \alpha')$, $E_\alpha = 43$ MeV, angular distribution and $\text{Ca}^{40}(\alpha, \alpha'\gamma)$ particle-gamma angular correlation measurements of Shook.¹ The $\text{Ca}^{40}(\alpha, \alpha')$, $E_\alpha = 44$ MeV, angular distribution measurements of Saudinos *et al.*² indicated a 5^- assignment but did not exclude 1^- . The $\text{Ca}^{40}(p, p'\gamma)$, $E_p = 150$ MeV, particle-gamma angular correlation measurements of Rowe *et al.*³ yielded a 3^- assignment. The present experiment was undertaken to help determine the spin and parity of the 4.48-MeV level.

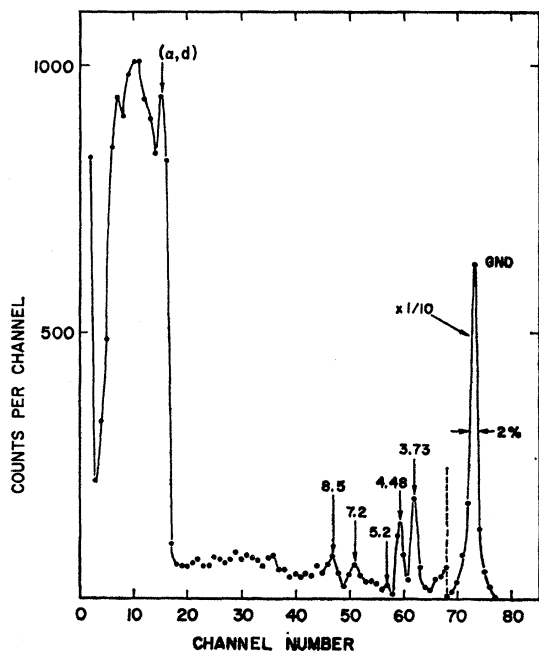

FIG. 1. Charged particle spectrum from the bombardment of a 0.5-mg/cm² natural calcium foil with 22-MeV alpha particles. $\theta_{\text{lab}} = 32\frac{1}{2}$ deg.

[†] Supported in part by the Office of Naval Research.

* A preliminary report of this work was presented at the Washington meeting of the American Physical Society, 1962 [Bent, Blatchley, and Eidson, *Bull. Am. Phys. Soc.* 7, 302 (1962)].

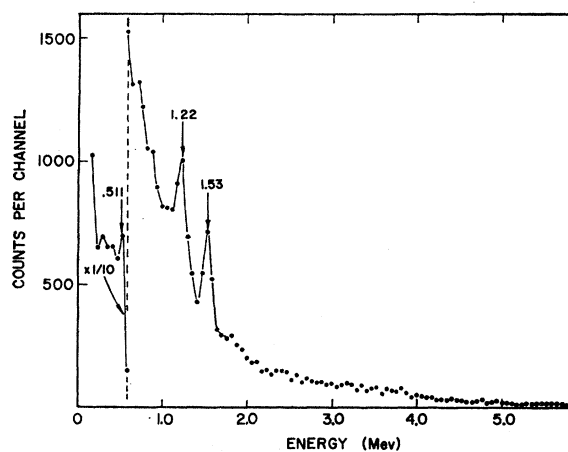

FIG. 2. Single-crystal gamma-ray spectrum from the bombardment of a 0.5-mg/cm² calcium foil with 22-MeV alpha particles. $\theta_\gamma = 90$ deg.

¹ G. B. Shook, *Phys. Rev.* 114, 310 (1959).

² J. Saudinos, R. Beurtey, P. Catillon, R. Chaminade, M. Crut, H. Faraggi, A. Papineau, and J. Thirion, *Compt. rend.* 252, 260 (1961).

³ D. J. Rowe, A. B. Clegg, G. L. Salmon, and D. Newton, *Proceedings of the Rutherford Jubilee International Conference*, Manchester, 1961 (Heywood & Co., Ltd., London, 1961).

II. APPARATUS AND PROCEDURES

The apparatus used to make the measurements reported in this paper was the same as that used in earlier work⁴ except for the changes described below.

A Hughes solid-state detector was used for charged particle energy measurements. It was placed 2 in. from the target and collimated with a vertical slit $\frac{1}{2}$ in. high $\times \frac{3}{16}$ in. wide. The gamma ray detector was a Harshaw 3×3 -in. NaI(Tl) crystal placed in the scattering plane with its front face $4\frac{1}{2}$ in. from the target. Targets were prepared by vacuum evaporation of natural calcium onto microscope slides. Self-supporting calcium foils approximately 1 in. square and 0.5 mg/cm^2 thick were then peeled off the slides using a razor blade. These foils were quickly mounted and placed in a vacuum and were found to contain negligible oxygen contamination.

The data shown in Figs. 2 to 7 were recorded with an RIDL 100-channel pulse-height analyzer. No corrections have been applied to the data points for background or accidental coincidence counts. The coincidence runs were made with an average beam current of about $0.001 \mu\text{A}$.

III. EXPERIMENTAL RESULTS

Figure 1 shows the charged particle spectrum obtained with the solid-state detector at a laboratory angle of $32\frac{1}{2}$ deg with respect to the beam direction. This spectrum shows strong peaks corresponding to the 3.73- and 3.90-MeV (unresolved) and 4.48-MeV states of Ca^{40} . Inelastic alphas corresponding to the 3.35-MeV 0^+ level are not observed at this angle or at other angles between $\theta_{\text{lab}} = 20$ and 140 deg.⁵ The strong peaks below channel 15 are attributed to deuterons from the reaction $\text{Ca}^{40}(\alpha, d)\text{Sc}^{42}$.

Figure 2 shows a single crystal gamma-ray spectrum obtained with the 3×3 NaI crystal. The strong peaks at 1.22 and 1.53 MeV are tentatively assigned to the reaction $\text{Ca}^{40}(\alpha, d\gamma)\text{Sc}^{42}$. Gamma rays at 0.75 and 3.8 MeV from the reaction $\text{Ca}^{40}(\alpha, \alpha'\gamma)$ are barely resolved in this single-crystal spectrum. The 0.511- and 1.28-MeV gamma rays from a Na^{22} source were used for energy calibration.

⁴ R. D. Bent and W. W. Eidson, Phys. Rev. **122**, 1514 (1961).

⁵ It was also observed in the experiments of Shook (reference 1) and Saudinos *et al.* (reference 2) at about 44-MeV bombarding energy that the 3.35-MeV 0^+ state of Ca^{40} is not excited with detectable intensity by inelastic alpha-particle scattering. This state is readily excited, however, by inelastic proton scattering. In the $\text{Ca}^{40}(p, p')$ experiments of Braams [C. M. Braams, Phys. Rev. **101**, 1764 (1956)] at 6.92-MeV bombarding energy the 3.35-MeV 0^+ state is excited with about the same intensity as the 3.73- and 4.48-MeV states. The weak excitation of the 3.35-MeV 0^+ state by inelastic alpha scattering can be qualitatively understood if it is assumed that the alpha scattering occurs mainly at the nuclear surface by direct interaction, and that the 0^+ excited state has a configuration such as $(d_{3/2})^{-2}(f_{7/2})^2$, requiring the excitation of two nucleons by the scattered particle. A scattered alpha particle then has a low probability for exciting two nucleons by successive collisions, whereas a proton, which penetrates further into the nucleus, may more readily do so.

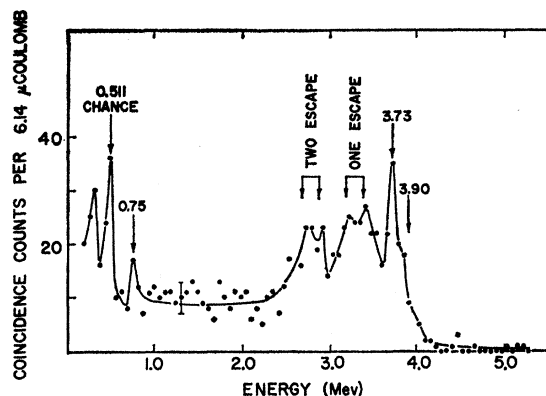

FIG. 3. Gamma-ray spectrum coincident with inelastically scattered alpha particles corresponding to the 3.73- and 3.90-MeV (unresolved) states of Ca^{40} . $\theta_\gamma = 90$ deg, $\theta_{\alpha'} = 32\frac{1}{2}$ deg. Time = 2 h, 29 min. True/chance = 80.

Figure 3 shows the gamma-ray spectrum coincident with inelastically scattered alpha particles corresponding to the 3.73- and 3.90-MeV states of Ca^{40} . The total time required for this run was 2 h, 29 min. No corrections have been applied for background or accidental coincidence counts. A true/chance ratio of 80 is obtained by comparing Fig. 3 with Fig. 2. This spectrum shows strong peaks corresponding to a 3.73-MeV gamma ray, weak evidence for a 3.9-MeV gamma ray, and a weak 0.75-MeV peak which is due to the inclusion within the particle window of some alpha particles corresponding to the 4.48-MeV state (see Fig. 4). The 0.511-MeV peak is due to accidental coincidences.

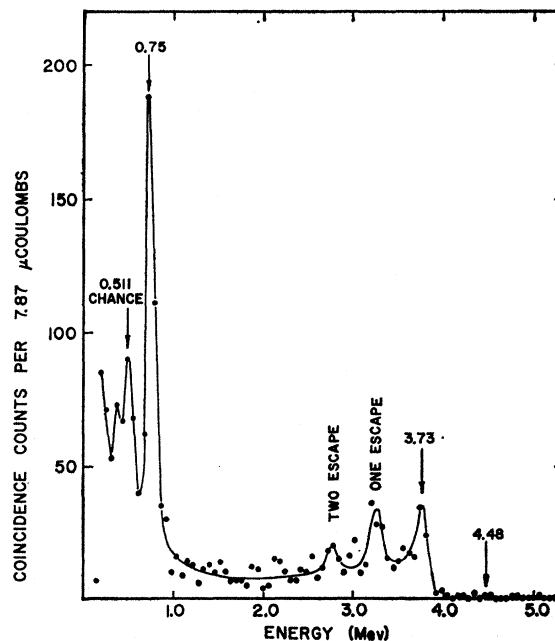

FIG. 4. Gamma-ray spectrum coincident with inelastically scattered alpha particles corresponding to the 4.48-MeV state of Ca^{40} . $\theta_\gamma = 90$ deg, $\theta_{\alpha'} = 32\frac{1}{2}$ deg. Time = 2 h, 37 min. True/chance = 90.

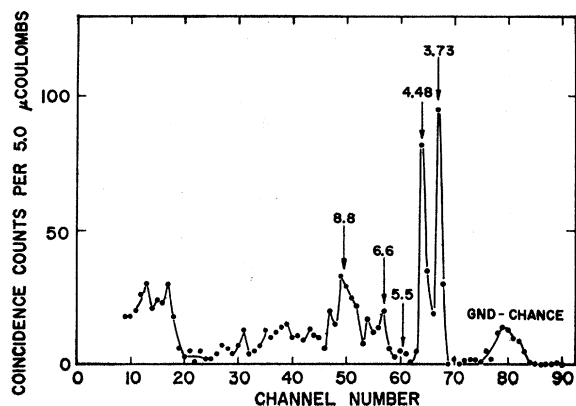

FIG. 5. Charged-particle spectrum coincident with 2.95- to 3.85-MeV gamma radiation. $\theta_\gamma = 90$ deg, $\theta_{\alpha'} = 32\frac{1}{2}$ deg. Time = 2 h. True/chance = 240.

Figure 4 shows the uncorrected gamma-ray spectrum coincident with inelastically scattered alpha particles corresponding to the 4.48-MeV state of Ca^{40} . Peaks are seen corresponding to gamma rays with energies of 0.75 and 3.73 MeV. Correcting for detector efficiency, these two gamma rays are found to have about the same intensity. This clearly shows that the 4.48-MeV level cascades to the 3.73-MeV level with the emission of a 0.75-MeV cascade gamma ray. No ground-state transition from the 4.48-MeV level is observed. An upper limit of 5% is placed on the intensity of this branch. Upper limits of 10% are placed on the 4.48 \rightarrow 3.35 and 4.48 \rightarrow 3.90 branches.

To check these results, measurements were made of charged particle spectra coincident with gamma rays of various energies. Figure 5 shows the uncorrected particle spectrum coincident with 2.95 to 3.85-MeV gamma radiation. A comparison of this spectrum with Fig. 1 gives a true/chance ratio of 240.

Figure 6 shows the particle spectrum coincident with 4.1- to 4.6-MeV gamma radiation. A comparison of Fig. 6 with Fig. 5 shows that the intensity of the ground state branch from the 4.48-MeV level is less than 2%, in agreement with the results obtained from Fig. 4. The few counts at 3.7 and 4.48 MeV in Fig. 6 may be due to the inclusion within the gamma-ray window of some 3.7-MeV gamma rays due to pile-up.

Figure 7 shows the particle spectrum coincident with 0.45- to 0.90-MeV gamma radiation. This spectrum

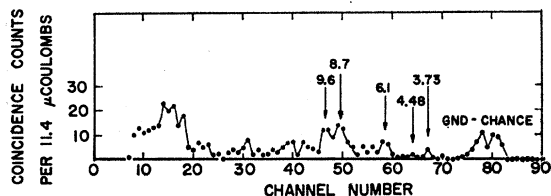

FIG. 6. Charged-particle spectrum coincident with 4.1- to 4.6-MeV gamma radiation. $\theta_\gamma = 90$ deg, $\theta_{\alpha'} = 32\frac{1}{2}$ deg. Time = 5 h, 11 min. True/chance = 150.

verifies the existence of the low-energy cascade transition from the 4.48-MeV level. Taking into consideration the fact that the gamma-ray window used for this spectrum was about six times more efficient for counting 0.75-MeV gamma radiation than for counting 3.7-MeV gamma rays, Fig. 7, together with Fig. 4, shows that the 4.48-MeV level decays with greater than 96% probability by low-energy cascade. Figure 7 also shows states at about 6.6 and 8.7 MeV in Ca^{40} and low-energy deuteron peaks which are coincident with low-energy gamma radiation.

The broadening of the ground-state peaks in Figs. 5 to 7 is probably due to the use of too low an operating voltage on the solid-state detector for these runs, which allowed some elastically scattered alpha particles to penetrate through the sensitive region of the detector.

Figure 8 is an energy level diagram for Ca^{40} which summarizes the results obtained from the present experiments for the decay of the 4.48-MeV level.

IV. DISCUSSION OF RESULTS

In the discussion that follows, it is assumed that the 3.73-MeV level of Ca^{40} is 3^- . Several experiments^{2,3,6} support this assignment.

If a 1^- spin and parity assignment is made for the 4.48-MeV level, then the extreme single-particle estimate⁷ gives the result that the 4.48-MeV $E1$ transition to the ground state should be 4×10^7 times more intense than the 0.75-MeV $E2$ cascade transition. Experimentally, we find that the intensity of the 4.48-MeV ground-state transition is less than 5% that of the 0.75-MeV cascade transition. This requires, assuming a maximum $E2$ enhancement of 1000, an $E1$ strength of $|M|^2 < 2$

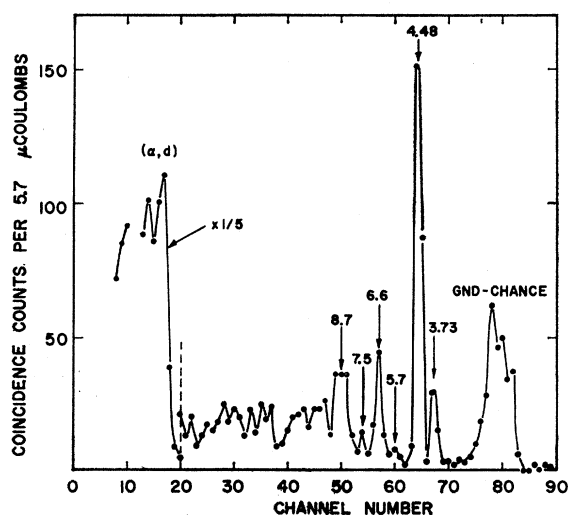

FIG. 7. Charged-particle spectrum coincident with 0.45- to 0.90-MeV gamma radiation. $\theta_\gamma = 90$ deg, $\theta_{\alpha'} = 32\frac{1}{2}$ deg. Time = 1 h, 54 min. True/chance = 150.

⁶ R. H. Helm, Phys. Rev. **104**, 1466 (1956).

⁷ D. H. Wilkinson, *Nuclear Spectroscopy, Part B*, edited by F. Ajzenberg-Selove (Academic Press Inc., New York, 1960).

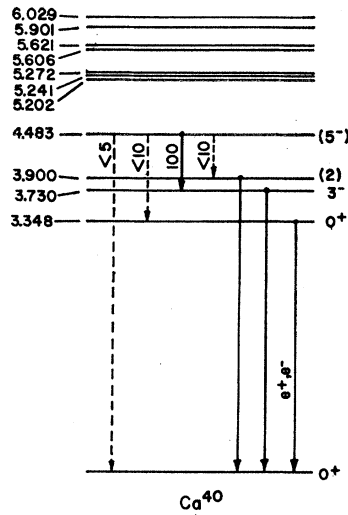

FIG. 8. Energy levels of Ca^{40} .

$\times 10^{-6}$, in Weisskopf units. The weakest known⁷ isotopic-spin-forbidden $E1$ transitions in light nuclei have strengths of about $|M|^2 = 10^{-5}$. Weaker $E1$ transitions are found in heavy nuclei for transitions between collective states. If the Ca^{40} 4.48-MeV level has single-particle structure, it is unlikely that it is 1^- .

The present experiment was performed at only one set of angles. It is possible that the angles chosen, $\theta_{\alpha'} = 32\frac{1}{2}$ deg, $\theta_{\gamma} = 90$ deg, were not optimum for detecting a weak 4.48-MeV transition. It is expected, however,

that $\alpha' - \gamma$ angular correlation effects probably are not strong enough to alter the main conclusion.

The $\text{Ca}^{40}(\alpha, \alpha')$ angular distribution measurements of Saudinos *et al.*² suggest that the 4.48-MeV level is 5^- but do not exclude the possibility of 1^- . The failure in the present experiment to detect the ground-state transition from the 4.48-MeV level is strong evidence against the 1^- assignment. These two experiments together, then, indicate that the 4.48-MeV level is 5^- .

To the author's knowledge, there have been no theoretical predictions for the position of a low-lying 5^- state in Ca^{40} . Carter, Pinkston, and True⁸ have calculated the lowest odd parity excited energy levels of the doubly closed shell Pb^{208} nucleus by a shell-model approach considering a single proton or a single neutron to be excited out of the Pb^{208} core. It would be interesting to see what similar calculations would predict for Ca^{40} . Here low-lying negative-parity levels corresponding to the excitation of single nucleons from the $2s$ and $1d$ shells to the $1f$ and $2p$ shells are expected. A 5^- state can be formed by coupling an $f_{7/2}$ particle to a $d_{3/2}$ hole.

V. ACKNOWLEDGMENTS

The authors are indebted to Professor M. B. Sampson for his advice and assistance in achieving optimum cyclotron performance and to Professor A. C. G. Mitchell for his encouragement and support.

⁸ J. C. Carter, W. T. Pinkston, and W. W. True, *Phys. Rev.* **120**, 504 (1960).