

Determination of $M1$ - $E2$ Mixing Amplitudes in Mg^{25} , Al^{27} , Si^{29} , and P^{31}

G. J. McCALLUM*

Atomic Energy of Canada Limited, Chalk River, Ontario, Canada

(Received March 13, 1961)

A method of analyzing gamma-ray angular distribution and direction-polarization data to yield values for the relative amplitudes of mixed multipole gamma-ray transitions is described. The analysis of the data does not demand a knowledge of the mechanism of formation of the gamma-emitting level. Measurements are reported on some mixed $M1$ - $E2$ de-excitation gamma rays from low-lying levels in Mg^{25} , Al^{27} , Si^{29} , and P^{31} ; these levels were excited by inelastic proton scattering. The following results were obtained:

Nucleus	Initial state		Final state		$E2$ amplitude $M1$ amplitude
	Energy (Mev)	Spin and parity	Energy (Mev)	Spin and parity	
Mg^{25}	0.98	$\frac{3}{2}^+$	ground state	$\frac{5}{2}^+$	0.30 ± 0.15
	0.98	$\frac{3}{2}^+$	0.58	$\frac{1}{2}^+$	0.15 ± 0.05
Al^{27}	1.01	$\frac{3}{2}^+$	ground state	$\frac{5}{2}^+$	-0.32 ± 0.14
Si^{29}	1.28	$\frac{3}{2}^+$	ground state	$\frac{1}{2}^+$	0.21 ± 0.03
P^{31}	1.27	$\frac{3}{2}^+$	ground state	$\frac{3}{2}^+$	-0.25 ± 0.15

1. INTRODUCTION

A DETERMINATION of the linear polarization of gamma radiation can yield information on the multipole mixing ratio and the parity change between the initial and final states involved in the transition. Although a knowledge of the multipole mixing ratio can often provide a useful test of a nuclear model, to date few polarization measurements have been reported on the de-excitation radiation of excited states of nuclei formed in nuclear reactions.

Until recently the methods commonly used in nuclear reaction studies to determine multipole mixing ratios of gamma rays demanded a knowledge of the reaction mechanism. Where these methods can be applied they have the great advantage that one simple measurement (e.g., a direct angular correlation) usually suffices to determine the mixing ratio. In the case of de-excitation gamma rays from levels of spins 1 or $\frac{3}{2}$, the direct angular correlation must be supplemented by some other measurement, such as a direction-polarization determination,^{1,2} or a triple angular correlation,³ to obtain a value for the mixing ratio. More recently Litherland and Ferguson⁴ have developed techniques for analyzing the results of triple angular correlation experiments; these methods enable level spins and multipole mixing ratios to be obtained without a knowledge of the reaction mechanism.

The present paper follows in the spirit of the work of Litherland and Ferguson, and in Sec. 2 we show that simultaneous direct angular correlation and linear polarization measurements yield a numerical expression for the mixing ratio independently of the reaction mechanism. In general, this expression gives two possible

values for the multipole mixing ratio of the radiation concerned.

In Secs. 3 and 4 the experimental procedures used in determining the direction polarization correlations in the present measurements are described, and in Sec. 5 the results are presented.

The following mixed $M1$ - $E2$ transitions were studied in the present experiments: (i) 0.980-Mev $\frac{3}{2}^+ \rightarrow \frac{5}{2}^+$ transition to ground state and the 0.400-Mev $\frac{3}{2}^+ \rightarrow \frac{1}{2}^+$ transition to the first excited state in Mg^{25} ; (ii) 1.013-Mev $\frac{3}{2}^+ \rightarrow \frac{5}{2}^+$ transition to ground state in Al^{27} ; (iii) 1.28-Mev $\frac{3}{2}^+ \rightarrow \frac{1}{2}^+$ transition to ground state in Si^{29} ; and (iv) 1.27-Mev $\frac{3}{2}^+ \rightarrow \frac{1}{2}^+$ transition to ground state in P^{31} . Measurements were made on these nuclei because the cross section for excitation by inelastic proton scattering is high and some direct angular correlation measurements were already available. In addition, since the unified model had already been applied with some success to the description of these nuclei,⁵⁻⁸ the results of the present measurements could provide further tests of the model.

Although in the experiments reported here inelastic proton scattering was used to excite the levels of interest, the method applies generally to all types of reactions, providing the gamma ray under investigation is emitted by one state of definite spin and parity, and no previous radiation (particle or gamma ray) is observed. The method cannot be applied to mixed de-excitation gamma rays from levels of spin $\frac{1}{2}$.

2. THEORY

The determination of only $E2/M1$ amplitude mixing ratios is considered in this paper, although the analysis

* Seconded from the Institute of Nuclear Sciences, Wellington, New Zealand.

¹ F. K. McGowan and P. H. Stelson, Phys. Rev. **109**, 901 (1958).

² M. Suffert, P. M. Endt, and A. M. Hoogenboom, Physica **25**, 659 (1959).

³ C. Broude, L. L. Green, and J. C. Willmott, Proc. Phys. Soc. (London) **72**, 1115 (1958).

⁴ A. E. Litherland and A. J. Ferguson, Can. J. Phys. (to be published).

⁵ A. E. Litherland, H. McManus, E. B. Paul, D. A. Bromley, and H. E. Gove, Can. J. Phys. **36**, 378 (1958).

⁶ E. Almqvist, D. A. Bromley, H. E. Gove, and A. E. Litherland, Nuclear Phys. **19**, 1 (1960).

⁷ D. A. Bromley, H. E. Gove, and A. E. Litherland, Can. J. Phys. **35**, 1057 (1957).

⁸ C. Broude, L. L. Green, and J. C. Willmott, Proc. Phys. Soc. (London) **72**, 1122 (1958).

applies equally well to M2/E1 mixtures and with some extension to higher multipole mixtures. Furthermore, it is assumed that the gamma-ray transitions under discussion proceed from one state of definite spin and parity to another state of definite spin and parity. In this case, both the angular correlation and direction-polarization correlation of the gamma ray with respect to the incident-beam direction can be expanded in terms of Legendre and associated Legendre polynomials of even order if we confine our discussion to linear polarization measurements. Following the suggestion of Rose⁹ we will define a mixing ratio δ in terms of the reduced matrix elements so that the intermediate state always appears on the left in the reduced matrix elements; that is,

$$\delta = \langle J \| L' \| I \rangle / \langle J \| L \| I \rangle,$$

where J is the spin of the intermediate level, I the spin of the final level, and L and L' ($L' > L$) are the multiplicities of the gamma rays under investigation.

The angular distribution $W(\theta)$ of gamma rays of mixed multipolarity LL' emitted following de-excitation of a nuclear level of spin J to a state of spin I is given by the relation¹⁰

$$W(\theta) \approx W_{LL}(\theta) + 2\delta W_{LL'}(\theta) + \delta^2 W_{L'L'}(\theta), \quad (1)$$

where

$$W_{LL'}(\theta) = \sum_k (-)^{I-J+k/2} \rho_{k0} Z_1(LJL'J, Ik) P_k(\cos\theta). \quad (2)$$

$$a_2/a_0 = \frac{-(-)^{I-J} \rho_{20} \{Z_1(1J1J, I2) + 2\delta Z_1(1J2J, I2) + \delta^2 Z_1(2J2J, I2)\}}{\rho_{00}(1+\delta^2)(2J+1)^{\frac{1}{2}}}, \quad (5a)$$

and

$$a_4/a_0 = \frac{(-)^{I-J} \rho_{40} \delta^2 Z_1(2J2J, I4)}{\rho_{00}(1+\delta^2)(2J+1)^{\frac{1}{2}}}, \quad (5b)$$

since $Z_1(LJLJ, I0) = (-)^{J-I} (2J+1)^{\frac{1}{2}}$ for all L and $Z_1(LJL'J, I0) = 0$ for $L \neq L'$.

The linear polarization intensity distribution for a gamma ray of multipolarity LL' can be expressed^{10,14} as

$$W_{LL'}(\theta, \gamma) = \sum_k (-)^{I-J+k/2} \rho_{k0} Z_1(LJL'J, Ik) \times \{P_k(\cos\theta) + (\pm)_{L'} K_k(LL') \cos 2\gamma P_k^2(\cos\theta)\}, \quad (6)$$

where θ is the angle between the gamma ray and the incident beam direction, and γ is the angle between the

$P_k(\cos\theta)$ is a Legendre polynomial of order k ; θ is measured relative to the incident-beam direction. ρ_{k0} , the statistical tensor¹⁰ describing the orientation of the gamma-emitting level, may be expressed in terms of the population $P(m)$ of the magnetic substates m of the level of spin J , by the relation

$$\rho_{k0} = \sum_m (-)^{J-m} P(m) (JJm-m | k0), \quad (3)$$

where $(JJm-m | k0)$ denotes the Clebsch-Gordan vector addition coefficient, and the Z_1 coefficient¹¹ is defined as

$$Z_1(LJL'J', Ik) = R(i^{L'-\pi'-L+\pi+2}) [(2L+1)(2L'+1)(2J+1)(2J'+1)]^{\frac{1}{2}} \times (LL'-11 | k0) W(LJL'J', Ik),$$

where R denotes "real part of," and π is zero for electric radiation and unity for magnetic radiation. The Racah W coefficients^{10,11} are nonzero only if the triads $(LL'k)$ and $(JJ'k)$ form the sides of a triangle. For transitions of the type under consideration, only terms up to $P_4(\cos\theta)$ will therefore appear in the Legendre polynomial expansion of the observed angular correlation, which may therefore be expressed as

$$W(\theta) = a_0 P_0(\cos\theta) + a_2 P_2(\cos\theta) + a_4 P_4(\cos\theta). \quad (4)$$

The expressions assume point detectors, and appropriate corrections¹² for finite detector size must, of course, be made in practical applications. From Eqs. (1), (2), and (4) we therefore obtain¹³ for the case of M1-E2 mixtures

gamma ray and the plane of the reaction after Compton scattering (see Fig. 1). The + sign in Eq. (6) is taken if the $2L'$ -pole radiation is electric, and the - sign, if magnetic. The quantity

$$K_k(LL') = -[(k-2)!/(k+2)!]^{\frac{1}{2}} \times (LL'11 | k2) / (LL'1-1 | k0)$$

has been tabulated by Fagg and Hanna,¹⁴ as well as numerical values of the associated Legendre function $P_k^2(\cos\theta)$ appearing in Eq. (6).

In practice, the intensities of the polarized radiation in the reaction plane and perpendicular to the reaction plane are usually measured; we may therefore define the polarization $P(\theta)$ of a mixed multipole transition by

$$P(\theta) = \frac{W_{LL}(\theta, \gamma=0^\circ) + 2\delta W_{LL'}(\theta, \gamma=0^\circ) + \delta^2 W_{L'L'}(\theta, \gamma=0^\circ)}{W_{LL}(\theta, \gamma=90^\circ) + 2\delta W_{LL'}(\theta, \gamma=90^\circ) + \delta^2 W_{L'L'}(\theta, \gamma=90^\circ)}, \quad (7)$$

with $W_{LL'}(\theta, \gamma)$ given by (6).

⁹ M. E. Rose, Oak Ridge National Laboratory Report ORNL-2516, 1958 (unpublished).

¹⁰ S. Devons and L. J. B. Goldfarb, *Handbuch der Physik*, edited by S. Flügge (Springer-Verlag, Berlin, 1957), Vol. 42, p. 326.

¹¹ W. T. Sharp, J. M. Kennedy, B. J. Sears, and G. M. Hoyle, Chalk River Report CRT-556, 1954 (unpublished).

¹² M. E. Rose, *Phys. Rev.* **91**, 610 (1953).

¹³ It can be seen that if the statistical tensors are known, an angular distribution measurement alone suffices to determine δ uniquely, if there are two nonzero ratios of the angular distribution expansion coefficients. See, for example, the Coulomb excitation measurements of reference 1.

¹⁴ L. W. Fagg and S. S. Hanna, *Revs. Modern Phys.* **31**, 711 (1959).

At $\theta=90^\circ$ the general expression for the polarization reduces to

$P(\theta=90^\circ)$

$$= \frac{(-)^{J-I}(1+\delta^2)(2J+1)^{\frac{1}{2}} - (\rho_{20}/\rho_{00})\{Z_1(1J1J,I2) - 2\delta Z_1(1J2J,I2) + \delta^2 Z_1(2J2J,I2)\} + (\rho_{40}/\rho_{00})\delta^2 Z_1(2J2J,I4)}{(-)^{J-I}(1+\delta^2)(2J+1)^{\frac{1}{2}} + 2(\rho_{20}/\rho_{00})\{Z_1(1J1J,I2) + \delta^2 Z_1(2J2J,I2)\} - \frac{1}{4}(\rho_{40}/\rho_{00})\delta^2 Z_1(2J2J,I4)} \quad (8)$$

Provided that the polarization measurement is made using the same reaction at the same energy at which the direct angular distribution was made, the statistical tensors in Eqs. (5a), (5b), and (8) are identical and may therefore be eliminated. In general, two values of δ are obtained, and except in the case of equal roots further information is required to remove this ambiguity. It should be noted that this result has been obtained without a knowledge of details of the formation of the level in question, and no assumption need be made that the reaction proceeds through an isolated resonance of the compound nucleus. The ambiguity can be removed if an angular distribution measurement of the gamma ray under investigation is made and details of the statistical tensors of the radiating level are known. For this measurement a different reaction may be used to populate the level of interest. Capture reactions for which details of the capturing state are known can often be used to determine the statistical tensors. Another method is to use the results of a special type of triple angular correlation measurement in which only those gamma rays emitted from particular magnetic substates are selected.¹⁵ An example of this is discussed in more detail in Sec. 4. The advantage of this latter method is that again no assumptions need be made that the reaction proceeds through an isolated resonance of the compound nucleus.

3. DETECTION SYSTEM

The experimental arrangement used for the simultaneous determination of the polarization and angular distribution of gamma rays emitted following inelastic proton scattering, is shown schematically in Fig. 1. The

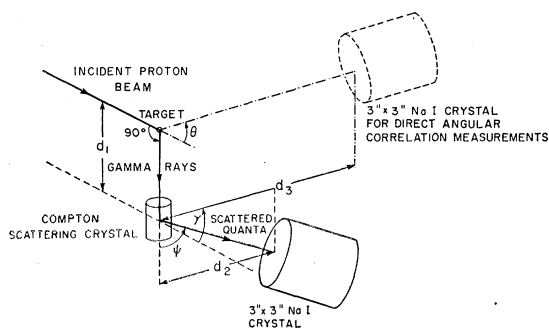

FIG. 1. Experimental arrangement employed for the simultaneous determination of the angular distribution and linear polarization of gamma rays excited by inelastic proton scattering.

¹⁵ A. E. Litherland and G. J. McCallum, Can. J. Phys. **38**, 927 (1960). The convention adopted in the present paper for the definition of δ was also used in this work.

Chalk River 3-Mv electrostatic accelerator provided the proton beams used in the experiments.

The polarization of gamma rays emitted at 90° to the incident-beam direction was measured by a Compton scattering polarimeter consisting of a scatterer, a 1-in. diam \times 1-in. thick NaI crystal, and a detector of the scattered quanta, a 3-in. diam \times 3-in. thick NaI crystal. The larger crystal could be rotated about an axis defined by the target center and the axis of the 1-in. diam crystal. Because of the sensitivity of the Compton scattering process to the polarization of the incident quanta, the linear polarization of the gamma rays can be determined by measuring the distribution of the Compton-scattered quanta as a function of the azimuthal angle γ . The relevant formalism has been given in the review article by Fagg and Hanna.¹⁴

If N is the ratio of the number of quanta scattered into the large counter when $\gamma=0^\circ$, to the number when $\gamma=90^\circ$, then the polarization P , defined earlier, is given by the relation

$$P = (1 - NR)/(N - R), \quad (9)$$

where R is the particular value of the ratio N obtained for a gamma ray completely polarized in the reaction plane.¹⁶ In the case of ideal geometry using point scatterers and detectors, R is simply the ratio of cross sections, $d\sigma(0^\circ)/d\sigma(90^\circ)$ for Compton scattering. The problems arising in the determination of P and R in the case of finite geometries are discussed below.

In practice, the spectrum of recoil electrons in the small crystal, in fast coincidence with the scattered quanta detected by the movable counter, was displayed on a 100-channel pulse-height analyzer. This arrangement permitted complex spectra to be analyzed. The reason for displaying the electron-recoil spectra rather than the spectra of the scattered quanta lies in the superior line shape of the former. To reduce random coincidences the larger crystal was shielded from direct radiation from the target by a 3-in. thick slab of lead. The distances d_1 and d_2 were 6.5 in. and 5.3 in., respectively. The coincidence resolving time was 25 nsec.

The crystal used to measure the direct angular correlation was placed as shown in Fig. 1; the distance d_3 varied between 10 and 25 in., depending on the gamma ray yield. The two large crystals were moved simultaneously; the lower crystal analyzed the polarization of quanta emitted at 90° to the incident beam by determining the intensity of gamma rays scattered at an

¹⁶ Note that the R defined here is the reciprocal of that used in reference 14.

angle γ with respect to the reaction plane, while the upper crystal determined the intensity of direct radiation emitted at an angle $\theta (= \gamma)$.

4. CALIBRATION OF THE POLARIMETER

As noted previously, in determining linear polarization from the azimuthal anisotropy of Compton-scattered radiation, it is necessary to know the expected anisotropy for a completely polarized gamma ray. In the case of a point scatterer and detector, the ratio R is simply the ratio of the differential cross sections for Compton scattering, $d\sigma_0/d\sigma_{90}$, of a gamma ray completely polarized in the reaction plane. The lowest curve in Fig. 2 shows this ratio plotted as a function of incident gamma-ray energy for a scattering angle $\psi = 81.5^\circ$. We will consider the effects of the finite size of the detector and scatterer, in turn. When the detector of the scattered quanta subtends a finite angle, the anisotropy is reduced; the value of R for two detector apertures, obtained by integration of the differential cross section, is shown in Fig. 2.¹⁷ These curves apply for a mean scattering angle of 81.5° , the value obtaining in the present experiments.

The first result of the finite extent of the scatterer is that we measure the polarization of gamma rays emitted over a range of angles with respect to the particle beam—our dimensions were chosen to limit this range to within less than $\pm 5^\circ$ of the mean angle, which was 90° in the present experiment. The finite dimensions of the scatterer also present problems for the accurate determination of the polarization of the gamma rays even if their direction is well defined; among the factors which

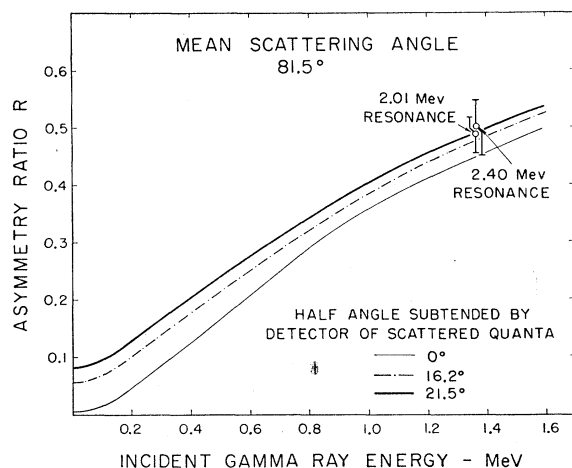

FIG. 2. Asymmetry ratio R , for gamma rays completely polarized in the reaction plane as a function of incident gamma-ray energy, for various detector apertures. These curves apply for a mean scattering angle of 81.5° . Experimental points obtained using the 1.37-Mev electric quadrupole radiation from the reaction $Mg^{24}(p, p'\gamma)Mg^{24}$.

¹⁷ These computations were carried out on the Chalk River Datatron computer by Mrs. L. L. Larson, using a program kindly prepared by Dr. J. M. Kennedy.

should be considered are the dependence of the mean scattering angle on the gamma-ray energy caused by changes in the average distance traveled by the quanta before scattering, and the effects of double scattering. The mean scattering angle can be calculated from a knowledge of the incident gamma-ray energy and the measured energy of the peak of the electron recoil spectrum. The effect of double scattering is difficult to assess, and this problem is being investigated. The experiment reported below, however, does suggest that with the geometry employed, the finite dimensions of the scatterer do not seriously modify the value of R calculated by integration of the differential Compton scattering cross section over the angles subtended by the detector of the scattered quanta.

Litherland and Gove¹⁸ have shown that the determination of the anisotropy of the 1.37-Mev pure $E2$ gamma ray excited in the reaction $Mg^{24}(p, p'\gamma)Mg^{24}$ can serve as a useful check on the calculated value of R ; this reaction was also used in the present experiment. For a pure $E2$ gamma ray with measured Legendre polynomial angular distribution coefficients a_0, a_2, a_4 the predicted polarization¹⁴ at 90° is given by the relation

$$P = (a_0 + a_2 + a_4) / (a_0 - 2a_2 - \frac{1}{4}a_4).$$

Taking into account the finite angle to the beam subtended by the scatterer, this relation is modified to

$$P = (a_0 + a_2 + 0.986a_4) / (a_0 - 1.995a_2 - 0.248a_4).$$

It can be seen that this represents only a small change from the point counter value.

Direct angular correlation and polarization measurements were made at the 2.01- and 2.40-Mev resonances¹⁹ in the $Mg^{24}(p, p'\gamma_{1.37})Mg^{24}$ reaction. A $40\text{-}\mu\text{g}/\text{cm}^2$ target of $^{20}Mg^{24}$ on a 0.020-in. tantalum backing was used. In obtaining the angular distribution coefficients from these and all subsequent measurements reported, corrections were made for gamma-ray absorption in the target backing and for the finite dimensions of the detectors. These latter corrections²¹ were very small as large source-detector distances were used; in the 2.01- and 2.40-Mev measurements the distances were 40 cm and 63 cm, respectively. A typical gamma-ray spectrum obtained at the 2.01-Mev resonance is shown in Fig. 3(a). The Legendre polynomial expansion coefficients were obtained by a least-squares fit to the experimental data, using the Chalk River Datatron computer; the results at 2.01 Mev are shown in Fig. 3(b). At the 2.01-

¹⁸ A. E. Litherland and H. E. Gove, Can. J. Phys. **39**, 471 (1961).

¹⁹ A. E. Litherland, E. B. Paul, G. A. Bartholomew, and H. E. Gove, Phys. Rev. **102**, 208 (1956).

²⁰ All the isotopically enriched targets used in the experiments reported were obtained from the Electromagnetic Separation Group, Atomic Energy Research Establishment, Harwell, England.

²¹ The appropriate finite geometry corrections are tabulated in a report by A. R. Rutledge, Chalk River Report CRP-851, 1959 (unpublished).

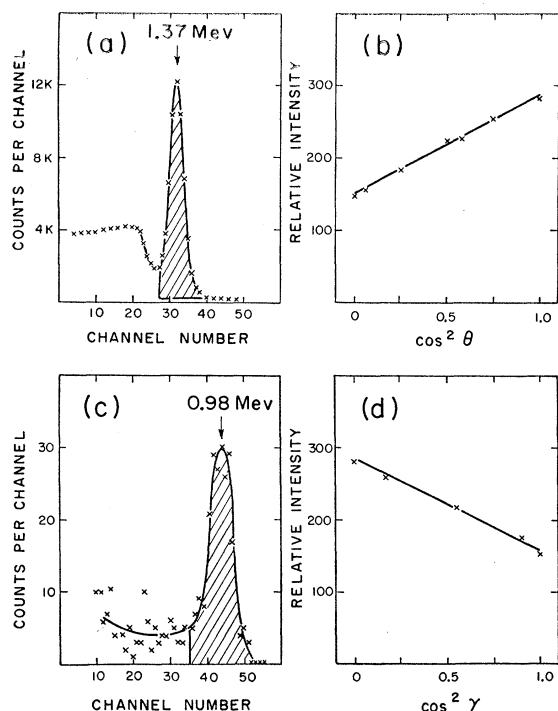

FIG. 3. $Mg^{24}(p,p'\gamma)Mg^{24}$ reaction. (a) Typical direct gamma-ray spectrum taken at the 2.01-Mev resonance. (b) The experimental results of the angular distribution measurements at 2.01 Mev are plotted together with the least-squares fit shown by the solid line. (c) Typical recoil electron spectrum obtained from the 1×1 in. diam crystal. (d) Intensity distribution of the Compton-scattered radiation together with the least-squares fit.

Mev resonance, the only significant coefficient was the $P_2(\cos\theta)$ term having the value 0.46 ± 0.01 ; at the 2.40-Mev resonance, the P_2 and P_4 terms were significant having the values 0.55 ± 0.02 and -0.52 ± 0.02 , respectively. These may be compared with the results of Litherland *et al.*¹⁹ They obtained $a_2 = 0.45 \pm 0.01$ at the 2.01-Mev resonance and $a_2 = 0.52 \pm 0.01$ and $a_4 = -0.58 \pm 0.01$ at the 2.40-Mev resonance.

In the evaluation of linear polarization, a measurement of the scattered intensity at $\gamma = 0^\circ$ and $\gamma = 90^\circ$ suffices to determine the ratio N , in Eq. (9). However, it was felt useful to make measurements of the intensity of the scattered radiation as a function of the angle γ , since this permitted a better check to be made on the internal consistency of the results. By measuring intensities in the two quadrants from $\gamma = -90^\circ$ to $\gamma = +90^\circ$, any anisotropy arising from lateral beam displacements was eliminated. A typical recoil-electron spectrum is shown in Fig. 3(c), and in Fig. 3(d) the results of a least-squares fit of the experimental results to the form $a + b \cos^2\gamma$ is illustrated. From the analyses, the following values of N were obtained: (1) $N = 0.54 \pm 0.02$ at 2.01 Mev, and (2) $N = 0.53 \pm 0.02$ at 2.40 Mev.

Using relation (9) and the results quoted above, two values for the asymmetry ratio R for 1.37-Mev gamma rays were obtained. These have been plotted in Fig. 2

together with the theoretical value for a point scatterer and ideal detector, as well as for finite detectors subtending angles of 16.2° and 21.5° . The finite dimensions of the scatterer are expected to somewhat reduce the asymmetry, but the true value should lie between the 16.2° and 21.5° curves. The agreement between the experimental points and computed curves show that the omission of the effects of double scattering cannot be serious at this energy.

In the measurements to be reported, an asymmetry ratio appropriate to a detector of scattered quanta subtending an angle of 19° has been assumed. In computing the polarization from experimental determinations of the asymmetry, an uncertainty of $\pm 5\%$ has been assumed in the value of R obtained from Fig. 2.

5. RESULTS

Mg^{25}

Measurements were made to determine the mixing ratio of the two de-excitation gamma rays from the second excited state of Mg^{25} . Details of the low-lying levels in Mg^{25} are illustrated in Fig. 4(a). Since the two gamma rays of interest result from de-excitation of the same level, the same statistical tensors describe both cases, and the ambiguity in the roots of the quadratic

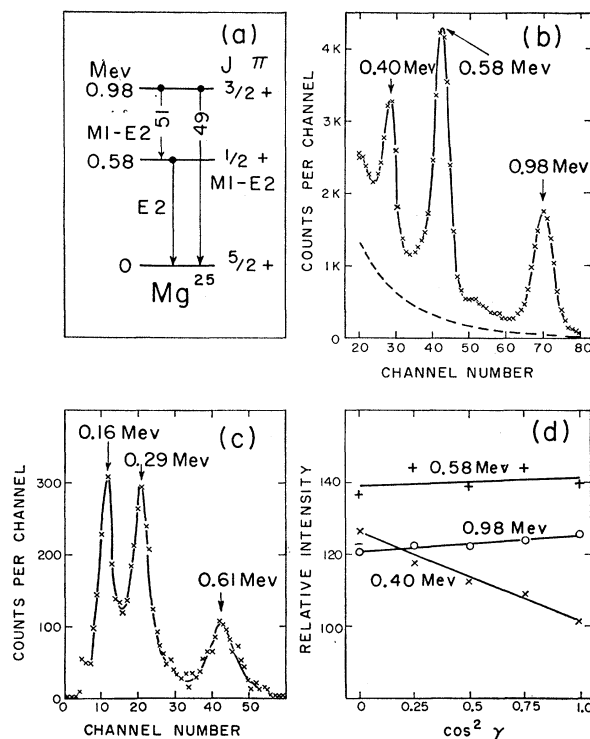

FIG. 4. $Mg^{25}(p,p'\gamma)Mg^{25}$ reaction. Measurements made at the 1.91-Mev resonance. (a) Details of the low-lying levels of Mg^{25} . (b) Direct gamma-ray spectrum. The room background is indicated by the dashed line. (c) Electron recoil spectrum. (d) Intensity distributions of the Compton-scattered radiation together with least-squares fit of the data to the predicted form, $a + b \cos^2\gamma$.

equations in the mixing ratios may in principle be eliminated. Furthermore, the 580-keV gamma ray arising from de-excitation of a level of spin $\frac{1}{2}$ has an isotropic and unpolarized de-excitation radiation which can be used to check for experimental asymmetries.

An enriched target of $Mg^{25} \sim 30 \mu g/cm^2$ thick on a 0.020-in. Ta backing was used for the experiment. Polarization and angular distribution measurements were made at the resonance in the $Mg^{25}(p, p'\gamma)Mg^{25}$ reaction²² corresponding to an incident proton energy of 1.91 MeV. From data such as those illustrated in Fig. 4(c), the intensities of the scattered radiation were measured as a function of the angle γ , and from this the linear polarization of the gamma rays emitted at 90° to the incident beam was deduced. The results of these measurements, together with the least-squares fit of the data to the form $a + b \cos^2 \gamma$, are illustrated in Fig. 4(d). The following values of N were obtained; $N = 1.04 \pm 0.01$, $1.02_6 \pm 0.02_3$, and 0.81 ± 0.02 for the 980-, 580-, and 400-keV transitions, respectively. The value of N for the 580-keV radiation is not significantly different from the predicted value of unity, and the deviation from unity probably reflects the difficulty of accurately analysing spectra such as that illustrated in Fig. 4(c) rather than an anisotropy due to misalignment of the apparatus. However, in evaluating the polarization of the 400- and 980-keV gamma rays, this uncertainty has been taken into account. The values of P derived are as follows: $P = 0.97 \pm 0.08$ and 1.41 ± 0.07 for the 980- and 400-keV transitions, respectively. The value of the a_2 coefficient [the value of the $P_0(\cos\theta)$ coefficient is assumed equal to unity throughout this paper] in the expansion of the direct angular correlation in terms of Legendre polynomials was found to be $a_2 = 0.08 \pm 0.01$ for the 980-keV quanta.

In Fig. 5 the results of the angular distribution and polarization measurements on the 980-keV gamma rays are illustrated. The ordinate is plotted on a scale linear in $\tan^{-1} \delta$, while the abscissa represents the range of possible values of the ratio ρ_{20}/ρ_{00} . The range of values of ρ_{20}/ρ_{00} can be obtained from the relation

$$\frac{\rho_{20}}{\rho_{00}} = \sum_m \frac{P(m)(5)^{\frac{1}{2}}[3m^2 - J(J+1)]}{[J(J+1)(2J-1)(2J+3)]^{\frac{1}{2}}}, \quad (10)$$

where the symbols are those defined in Eq. (3). The darkly hatched area represents the result of substituting the values obtained from the angular distribution measurements into Eq. (5a) with $J = \frac{3}{2}$ and $I = \frac{5}{2}$, while the lightly hatched area represents a plot of the polarization measurements where use has been made of Eq. (8). From the common area of the curves a value of $0.3 < \delta < 1$ is indicated. This range is consistent with the requirement that the product of the roots of the quadratic equation in δ is $7/25$, independently of the values of a_2

²² H. E. Gove, G. A. Bartholomew, E. B. Paul, and A. E. Litherland, Nuclear Phys. 2, 132 (1956/57).

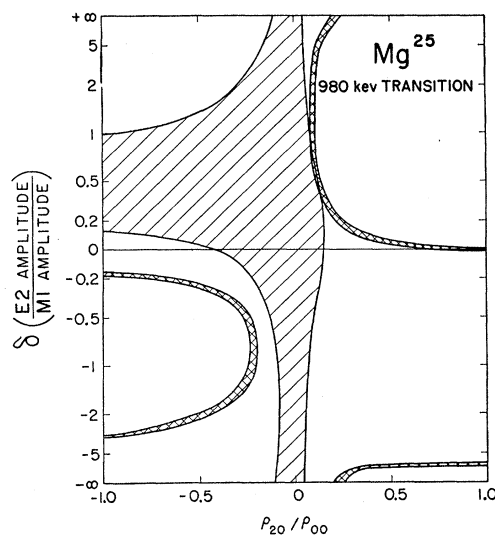

Fig. 5. The results of measurements on the 980-keV gamma ray are illustrated. The closely hatched areas represent the results of the angular distribution measurements, while the lightly hatched areas represent those of the polarization determination. The common area represents possible solutions.

and P . The plot also serves to show that the resonance at which the measurements were made was a rather unfortunate choice, having $\rho_{20}/\rho_{00} \approx 0.1$ and consequently yielding rather weak angular correlations.

Subsequently, angular distribution measurements were made at a resonance corresponding to $E_p = 2.41$ MeV. The following values of the a_2 coefficient were obtained; 0.22 ± 0.02 for the 980-keV radiation and 0.11 ± 0.02 for the 400-keV quanta. To obviate the large, angular-dependent background below the 400-keV photopeak [see Fig. 4(b)] the following procedure was adopted in the determination of the angular distribution of the 400-keV gamma rays. Only those gamma rays in fast coincidence (resolving time ~ 50 nsec) with 580-keV quanta were recorded; this yielded a clear 400-keV spectrum with no background, and enabled precise angular distribution measurements to be made. Since the 580-keV radiation arises from de-excitation of a level of spin $\frac{1}{2}$ it is isotropic and no distortion of the 400-keV angular distribution is produced by this technique.

The values of the angular distribution coefficients obtained at 2.41 MeV may be used to deduce a value for the a_2 coefficient of the 400-keV radiation at 1.91 MeV as follows. If we define the ratio of the angular distribution coefficients in the following way:

$$\mathcal{R} = \frac{a_2 \text{ coefficient of 400-keV gamma rays}}{a_2 \text{ coefficient of 980-keV gamma rays}},$$

it can be seen⁶ from Eq. (5a) that \mathcal{R} is independent of the statistical tensors. The following values of \mathcal{R} were obtained: $\mathcal{R} = 0.49 \pm 0.07$ at 2.41 MeV and $\mathcal{R} = 0.68 \pm 0.24$ at 1.91 MeV. From these a weighted mean of $\mathcal{R} = 0.51 \pm 0.07$ is computed. This latter value, together

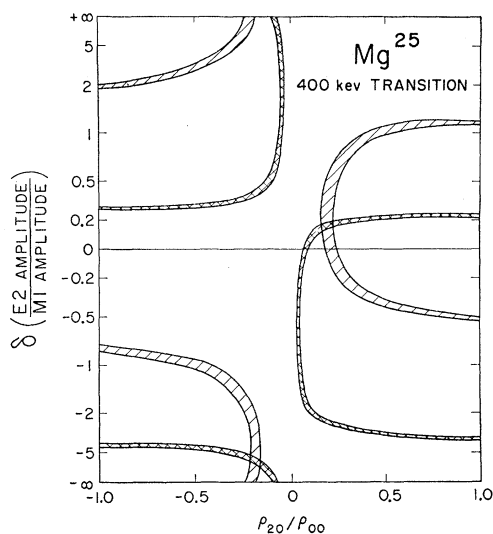

FIG. 6. Results of measurements on the 400-keV gamma ray. Since the same value of ρ_{20}/ρ_{00} apply in both Figs. 5 and 6, the only acceptable solution is the one with $\delta > 0$.

with the value of the a_2 coefficient of the 980-keV radiation at 1.91 MeV reported above, was used to obtain the value $a_2 = 0.042 \pm 0.008$ for the 400-keV angular distribution coefficient at 1.91 MeV; this more accurate value was used in determining the mixing ratio, rather than the directly measured value $a_2 = 0.06 \pm 0.02$.

In Fig. 6 the results of the angular distribution and polarization measurements of the 400-keV radiation are plotted as described above, with the closely hatched curve representing the angular correlation result. The two possible values of δ indicated are $0.11 < \delta < 0.20$ or $-5 < \delta < -9$. From the measurements on the 980-keV

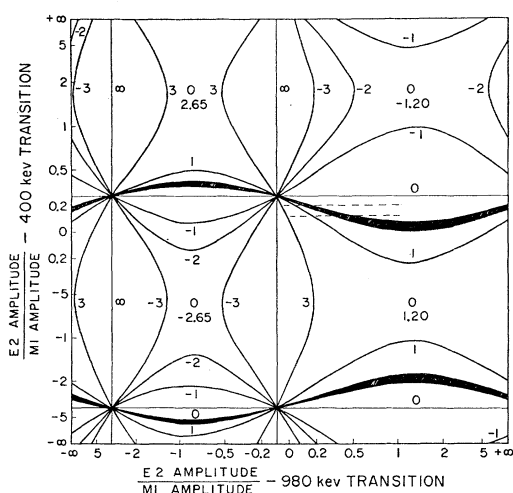

FIG. 7. The results of the simultaneous angular distribution measurements on the 980- and 400-keV transitions. The contour lines represent the loci of points with constant value of the ratio α , of the a_2 coefficients. The solid black areas represent the limits of the measured value of α , i.e., $0.44 < \alpha < 0.58$.

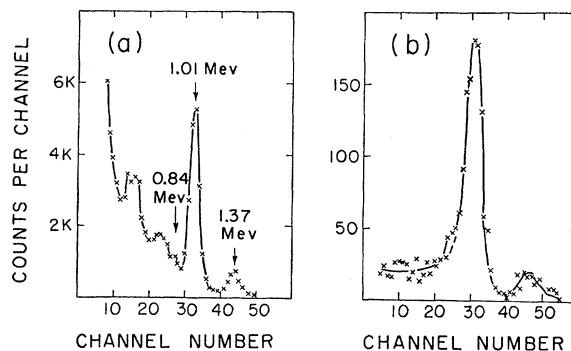

FIG. 8. $Al^{27}(p, p'\gamma)Al^{27}$ reaction. (a) Direct gamma-ray spectrum at $E_p = 2.13$ MeV. (b) Recoil electron spectrum at the same energy.

radiation we know $\rho_{20}/\rho_{00} > 0$; hence the solution $0.11 < \delta < 0.20$ is the correct one.

It is now of interest to attempt to obtain a more accurate value for the mixing ratio of the 980-keV radiation without employing the results of the rather imprecise polarization measurement. Using the value $\rho_{20}/\rho_{00} = 0.19 \pm 0.03$ indicated in Fig. 6, together with the value $a_2 = 0.08 \pm 0.01$, and substituting in Eq. (5a), we obtain $0.19 \leq \delta \leq 0.36$ as the only set of solutions compatible with the polarization measurements.

As pointed out by Almqvist *et al.*,⁶ we may also use the measured ratio of the angular distribution coefficients to obtain a relation between the values of the mixing ratios. The relation is given simply by the ratio of the appropriate expressions of the form given by Eq. (5a). Figure 7 represents contour plots of this relation for various values of α . The darkly shaded area represents the experimentally determined range of α , while the dashed lines show the limits of the mixing ratio of the 400-keV gamma ray. From this plot, the value $0.1 < \delta < 0.5$ is deduced for the mixing ratio of the 980-keV transition. From the three results, the following value of δ is estimated: $\delta = 0.3 \pm 0.15$ for the 980-keV radiation.

Al^{27}

Angular distribution and linear polarization measurements were made on the 1.013-MeV gamma ray arising from transitions from the $\frac{3}{2}^+$ second excited state to the $\frac{5}{2}^+$ ground state in Al^{27} . The level was excited by inelastic proton scattering at resonances corresponding to proton bombarding energies of 1.74 and 2.13 MeV (see Appendix). Almqvist *et al.*⁶ have studied these resonances in detail and have reported that the only significant coefficient in the expansion of the angular distribution in terms of Legendre polynomials is the $P_2(\cos\theta)$ term; they report $a_2 = -0.16 \pm 0.01$ at 1.74 MeV and $a_2 = 0.124 \pm 0.003$ at 2.13 MeV.

A target of aluminum evaporated onto a $\frac{1}{16}$ -in. thick pure graphite backing was used for the present measurements; this target was ~ 6 keV thick to 2-MeV

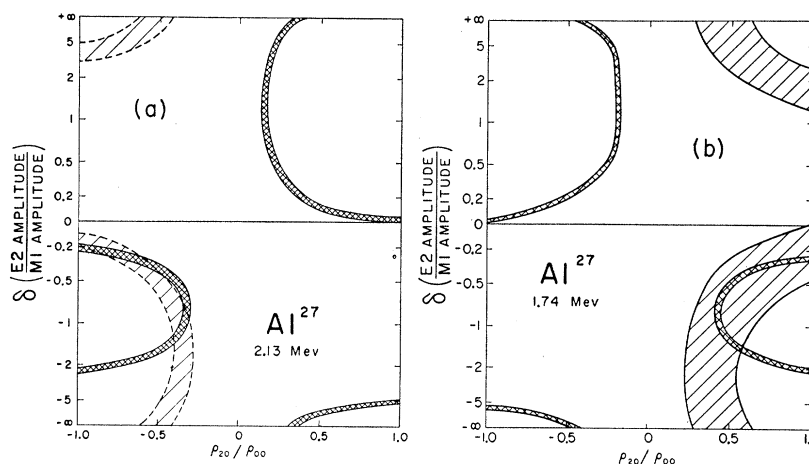

FIG. 9. The results of measurements on the 1.013-Mev transition in Al²⁷ at proton bombarding energies of (a) 2.13 Mev and (b) 1.74 Mev, are illustrated.

protons. The direct gamma-ray spectrum obtained at a proton bombarding energy of 2.13 Mev is shown in Fig. 8(a). The peak at 1.37 Mev arises from the reaction Al²⁷(*p*, $\alpha\gamma$)Mg²⁴. There is also evidence for a peak at 0.840 Mev which could arise from cascade de-excitation of the 1.013-Mev level via the 0.840-Mev first excited state, or by direct excitation of the 0.840-Mev level. The branching ratio for the former process is $\sim 2.4\%$ and may therefore account for all the 840-keV gamma rays observed. To prevent cascade de-excitations being recorded, the bias levels on the fast coincidence unit were adjusted to record coincidences only if the energy of the gamma rays entering the detectors both exceeded ~ 200 keV.

A measurement of the angular distribution of the 1.013-Mev gamma ray at $E_p = 2.13$ Mev yielded a value of 0.124 ± 0.014 for the $P_2(\cos\theta)$ expansion coefficient, in excellent agreement with Almqvist *et al.*⁶ The value for the anisotropy ratio N at this resonance was $N = 1.25 \pm 0.04$, which yields for the polarization, $P = 1.70 \pm 0.18$. These results are plotted in Fig. 9(a); as before, the darkly hatched areas represent the relation between δ and ρ_{20}/ρ_{00} obtained from the results of the angular correlation measurements; and the lighter areas, that resulting from the polarization determination. From the common area of these curves it can be deduced that δ lies in the range $-0.18 \leq \delta \leq -0.46$ or $-0.64 \leq \delta \leq -1.6$. In this case the ambiguity in the solutions can be eliminated by using the work of Metzger, Swann, and Rasmussen.²³ From their results on self-absorption and resonance scattering of gamma rays, together with the Coulomb excitation data of Lemberg²⁴ and Gove and Broude,²⁴ the value $\delta^2 = 0.064 \pm 0.03$ may be deduced, implying that the solution $\delta = -0.32 \pm 0.14$ is the correct one for the 1.013-Mev transition; however, it should be noted that the angular distribution measure-

ments of Metzger, Swann, and Rasmussen²³ favor a positive sign for δ .

From these data and measurements reported by Almqvist *et al.*⁶ the following values of δ for the 0.170-Mev transition between the second and first excited states of Al²⁷ may be deduced. These are $0 \leq \delta \leq 0.19$ or $-1.7 \leq \delta \leq -2.9$, with computations using the Nilsson eigenfunctions favoring the former choice.⁶

Due to the very high yield of 0.840-Mev radiation at the 1.74-Mev resonance, measurements at this bombarding energy are less accurate. From the measured anisotropy $N = 0.78 \pm 0.09$ and angular distribution measurements,⁶ the values of δ deduced overlap those reported above, as can be seen in Fig. 7(b).

Si²⁹

Linear polarization measurements were made on the 1.28-Mev gamma ray arising from a transition between the $\frac{3}{2}^+$ first excited state to the $\frac{1}{2}^+$ ground state. For this measurement a slightly different experimental arrangement was employed—the dimensions d_1 and d_2 were $5\frac{1}{2}$ and 5 in., respectively, and the angle ψ was 86° . The spectra of recoil electrons in slow coincidence (resolving time $\sim 5 \mu\text{sec}$) with gamma rays within a given energy range entering the large crystal were recorded. The energy range chosen was determined by the predicted spectrum of Compton-scattered quanta, the limits being set by the incident gamma-ray energy and the geometry chosen. The fast coincidence circuitry described above was employed in all the other measurements reported.

An enriched target of Si²⁹, $\sim 30 \mu\text{g}/\text{cm}^2$ thick, on a Ta backing was used for the experiments. Polarization measurements were made at the resonance in Si²⁹(*p*, $p'\gamma$)Si²⁹ corresponding to an incident proton energy of 2.80 Mev. From the measured anisotropy ratio $N = 1.37 \pm 0.05$, a polarization $P = 0.41 \pm 0.04$ is deduced. A direct angular correlation measurement of the 1.28-Mev gamma ray was not made, as a measurement at the 2.80-Mev resonance using the same target was already available. Bromley

²³ F. R. Metzger, C. P. Swann and V. K. Rasmussen, *Nuclear Phys.* **16**, 568 (1960).

²⁴ I. Kh. Lemberg, and H. E. Gove and C. Broude, in *Reactions Between Complex Nuclei*, edited by A. Zucker, F. T. Howard, and E. C. Halbert (John Wiley & Sons Inc., New York, 1960).

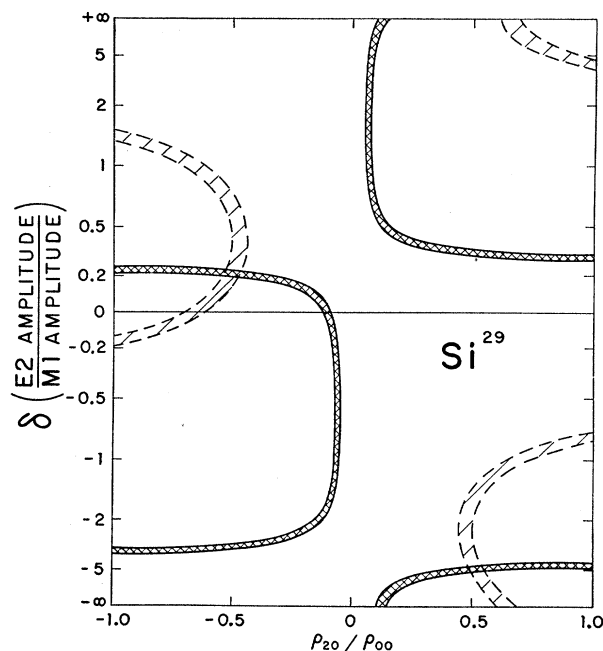

FIG. 10. Results of measurements on the 1.28-Mev transition in Si^{29} at $E_p=2.80$ Mev. From other information the solution with $\delta > 0$ is indicated.

*et al.*²⁵ report the values: $a_2 = -0.058 \pm 0.006$ and $a_4 = 0.012 \pm 0.018$. Since a $\frac{3}{2}^+ \rightarrow \frac{1}{2}^+$ transition can have no terms higher than $P_2(\cos\theta)$, a value of $a_2 = -0.06 \pm 0.01$ was used in the calculations. The results of the polarization and direct correlation measurements are plotted in Fig. 10. The plots indicate that in this case even a rather inaccurate polarization measurement would serve to determine accurately the two possible values of δ . The plots indicate that $0.16 \leq \delta \leq 0.24$ or $-4.2 \leq \delta \leq -5.3$.

In this case the ambiguity is eliminated by reference to the work of Litherland and McCallum.¹⁵ They studied the de-excitation of the 1.28-Mev level in Si^{29} via the reaction $\text{Mg}^{26}(\alpha, n\gamma)\text{Si}^{29}$. The angular correlation of the 1.28-Mev gamma rays in coincidence with neutrons detected at 0° with respect to the incident beam was measured. With this geometry and with both the target and projectile having zero spin, only gamma rays emitted by the $m = \pm \frac{1}{2}$ magnetic substates are detected, hence the statistical tensors are known and a set of values for δ was obtained. From the two measurements the value $\delta = 0.21 \pm 0.03$ is deduced.

It is of interest to note that in neither experiment is a knowledge of the compound system through which the reactions proceed required. However, the results do support the evidence of Bromley *et al.*²⁵ that at the resonance where the polarization measurements were made, the compound state involved is 3^- ; the following mechanism is assumed: f -wave formation with channel

²⁵ D. A. Bromley, H. E. Gove, E. B. Paul, A. E. Litherland, and E. Almqvist, *Can. J. Phys.* **35**, 1042 (1957).

spin 0 and decay by p -wave proton emission. This would demand a value of $-4/7$ for the ratio of the statistical tensors ρ_{20}/ρ_{00} , in close agreement with that measured.

P^{31}

Polarization measurements were made on the 1.265-Mev gamma rays arising from transitions between the $\frac{3}{2}^+$ first excited state and the $\frac{1}{2}^+$ ground state of P^{31} . The study was facilitated by the work of Almqvist and Ferguson who have studied the reaction $\text{P}^{31}(p, p'\gamma)\text{P}^{31}$ and made angular distribution measurements of the 1.265-Mev gamma ray at a number of resonances. This work is reported in the Appendix. Resonances corresponding to proton energies of 2.70 and 2.87 Mev were chosen for the present study; the relevant $P_2(\cos\theta)$ coefficients in the angular distributions are 0.15 ± 0.02 and -0.58 ± 0.03 . Angular distribution measurements at three angles, using the same target thickness as Almqvist and Ferguson, yielded comparable values for the coefficients, but in the analysis illustrated in Fig. 11 their more accurate values have been employed. The following linear polarization results were obtained: at $E_p = 2.70$ Mev, $N = 0.97 \pm 0.02$, yielding $P = 1.08_6 \pm 0.08$; and at $E_p = 2.98$ Mev, $N = 1.4 \pm 0.2$, corresponding to $P = 0.38 \pm 0.13$. In Figs. 11(a) and (b) the results of these measurements are plotted. From these two sets of measurements the following values for δ are deduced: $\delta = -0.25 \pm 0.15$, or $2.5 < \delta < 10$.

In this case, the measurements of Broude *et al.*³ on the $\text{Si}^{30}(p, \gamma)\text{P}^{31}$ reaction may be used to uniquely determine the value of δ . At the 500-keV resonance, they have measured the angular distribution of the direct transition to the 1.265-Mev level and the angular distribution of the 1.265-Mev gamma ray with the intermediate radiation unobserved. The only value of δ obtained from these measurements which is consistent with the results reported above is $\delta = -0.20 \pm 0.06$. In the measurements of Broude *et al.*³ the values of δ obtained were $\delta = -0.20 \pm 0.06$ or $\delta = -1.18 \pm 0.24$. To obtain a unique value of δ , a triple angular correlation measurement was made which favoured the latter value, although the value $\delta = -0.20 \pm 0.06$ was not definitely eliminated.

6. SUMMARY AND DISCUSSION

A method of analyzing the angular distribution and linear polarization of de-excitation gamma radiation following nuclear reactions, to yield values of the multipole mixing in the radiation, has been described. No knowledge of the reaction mechanism is demanded in the analysis. In general, the method yields two possible values of the mixing parameter δ , but in some cases a unique value can be found. In ambiguous cases, additional information from other types of investigations are used to uniquely determine δ .

It is of interest to compare the results of the measurements reported above with the predictions of the Nilsson

FIG. 11. Results of measurements on the mixing ratio of the 1.265-Mev radiation in P³¹. Measurements were made at (a) 2.70 Mev and (b) 2.87 Mev, respectively.

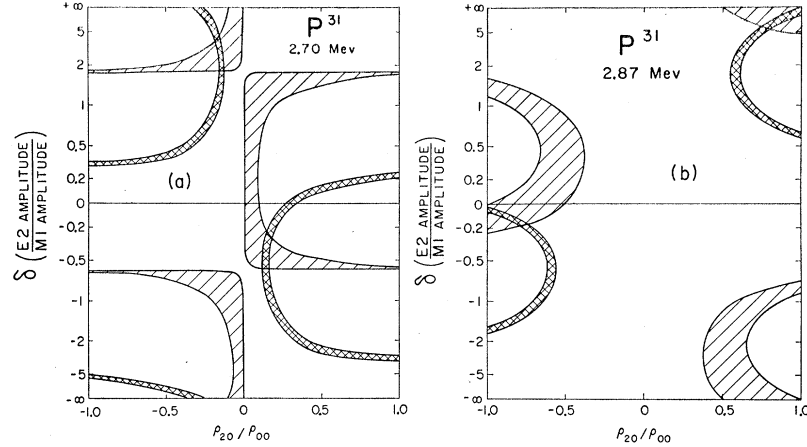

model.²⁶ According to this model the $\frac{3}{2}^+ \rightarrow \frac{1}{2}^+$ transitions to the ground states of Si²⁹ and P³¹ are similar, apart from the fact that in one case a neutron is involved in the transition, and in the other a proton is involved. This is also true of the $\frac{3}{2}^+ \rightarrow \frac{5}{2}^+$ transitions in Mg²⁵ and Al²⁷, which were measured, but in this case the model forbids magnetic dipole transitions. It has been shown⁵ that this selection rule is not an absolute one. In the calculations reported below for Mg²⁵ and Al²⁷, the ground state has been arbitrarily assumed to be a mixture of $K=\frac{1}{2}$ and $K=\frac{5}{2}$ bands and the formulas for transitions within a $K=\frac{1}{2}$ band have been employed in evaluating the magnetic dipole transition probabilities.

The E2/M1 mixing ratios predicted by the Nilsson model depend very sensitively upon the assumed nuclear distortion and the values of the parameters chosen for the single-particle Hamiltonian; however, for similar transitions it is possible to express the ratio of the amplitude mixtures in terms of quantities which do not depend sensitively on model parameters. Using Nilsson's formalism, we may express the ratio of the amplitude mixtures of similar neutron and proton transitions within a $K=\frac{1}{2}$ band as follows:

$$\delta_n/\delta_p = [Q_0\omega/G_0(1+b_0)]_n/[Q_0\omega/G_0(1+b_0)]_p,$$

where the subscripts n and p denote neutron and proton transitions, respectively. The ratio $(Q_0)_n/(Q_0)_p$ is simply the ratio of the effective charge involved in the transitions; this is estimated²⁷ to be

$$\simeq (Z_n/A_n)/[1+(Z_p/A_p)] \simeq \frac{1}{3}$$

in the cases considered.

In the case of Si²⁹ and P³¹, G_0 and b_0 may be expressed in terms of the gyromagnetic ratios, the magnetic moments (-0.555 and 1.13 nm, respectively), and the decoupling parameters [Nilsson's Eqs. (39) and (40)]. Using a value of 1.2 for the decoupling parameter^{7,8} we

obtain $\delta_{Si^{29}}/\delta_{P^{31}} = -0.25$ for the $\frac{3}{2}^+ \rightarrow \frac{1}{2}^+$ transition, in fair agreement with the observed value of -0.84 ± 0.52 , considering the large errors involved.

In the comparison of Mg²⁵ and Al²⁷ the ratios of the mixing amplitudes can be expressed in terms of the gyromagnetic ratios, the decoupling parameters, and the normalized expansion coefficient a_{21} . Using the values $a_{21}^2=0.5$, $a=-0.23$ for Mg²⁵,⁵ and $a=-0.72$ for Al²⁷,⁶ we obtain $\delta_{Mg^{25}}/\delta_{Al^{27}} = -0.52$ which is close to the observed value of -0.94 ± 0.69 .

The mixing ratio of the 950-keV $\frac{3}{2}^+ \rightarrow \frac{5}{2}^+$ transition to the ground state of Al²⁵ has been shown by Litherland *et al.*¹⁹ to have the value $0 \leq \delta^2 \leq 0.06$ with phase difference undetermined, or $5 \leq \delta^2 \leq 50$ with 180° phase difference (using our definition of δ). The calculations carried out above suggest that we may with some confidence predict the phase and the order of magnitude of $\delta_{Al^{25}}$ from the observed values of Al²⁷ and Mg²⁵. The ratios obtained are $\delta_{Al^{25}}/\delta_{Al^{27}} = 1.13$, yielding $\delta_{Al^{25}} = -0.36 \pm >0.16$ and $\delta_{Al^{25}}/\delta_{Mg^{25}} = -0.5$, which gives $\delta_{Al^{25}} = -0.6 \pm >0.3$. Combined with the results of Litherland *et al.*¹⁹ this implies $\delta_{Al^{25}} \approx -0.2$ for the 950-keV transition to the ground state.

ACKNOWLEDGMENTS

The writer has greatly benefited from many discussions with members of the Nuclear Physics Division, Chalk River Laboratories; in particular, the advice and encouragement of Dr. A. E. Litherland and Dr. A. J. Ferguson is gratefully acknowledged. The assistance of Miss A. R. Rutledge in the reduction of much of the data was greatly appreciated. Thanks are also due to C. E. L. Gingell for his assistance with the electronic system employed in the experiments, and to P. G. Ashbaugh and his staff for the operation of the accelerator. The author is also indebted to Dr. E. Almqvist for valuable criticisms of the manuscript during its preparation. Finally, the author wishes to take this opportunity to express his appreciation for the hospitality extended to him by Dr. L. G. Elliott and Dr. H. E. Gove during his sojourn at Chalk River.

²⁶ S. G. Nilsson, Kgl. Danske Videnskab. Selskab, Mat.-fys. Medd. 29, No. 16 (1955).

²⁷ B. R. Mottelson and S. G. Nilsson, Kgl. Danske Videnskab. Selskab, Mat.-fys. Skrifter 1, No. 8 (1959).

APPENDIX. EXCITATION CURVES²⁸ FOR THE REACTIONS $\text{Al}^{27}(p, p'\gamma)\text{Al}^{27}$ ($Q = -1.013$ Mev) AND $\text{P}^{31}(p, p'\gamma)\text{P}^{31}$ ($Q = -1.265$ Mev)

The data presented in this Appendix were taken several years ago during a survey of some $(p, p'\gamma)$ reactions. They have not been published previously but are included here because they facilitated the studies in this paper and may similarly be of use to other experimenters. In addition, they allow easy identification of the resonances at which the detailed spectroscopic measurements reported in this paper were made, by using techniques which do not require clearly resolved resonance structure.

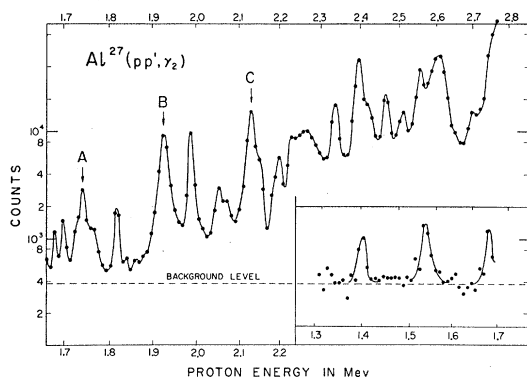

FIG. 12. The yield of 1.01-Mev gamma radiation from the reaction $\text{Al}^{27}(p, p'\gamma)\text{Al}^{27}$, at 0° , in the proton energy range 1.3–2.7 Mev. The form of the Legendre polynomial expansion fitted to the angular distributions at resonance *A* is $1 - 0.16(\pm 0.01)P_2$, at resonance *B* is isotropic, and at resonance *C* is $1 + 0.124(\pm 0.003)P_2$.

²⁸ These data were obtained by E. Almqvist and A. J. Ferguson.

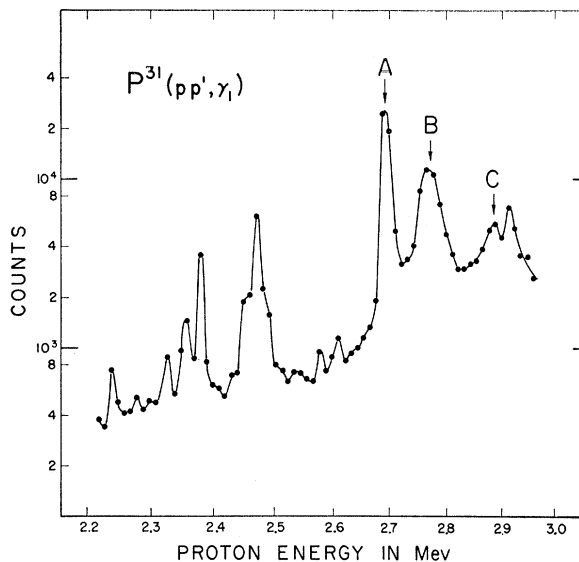

FIG. 13. The yield of 1.265-Mev radiation from the reaction $\text{P}^{31}(p, p'\gamma)\text{P}^{31}$, at 90° , in the proton energy range 2.2–2.95 Mev. The form of the Legendre polynomial expansion fitted to the angular distributions at resonance *A* is $1 + 0.15(\pm 0.02)P_2$, at resonance *B* is isotropic, and at resonance *C* is $1 - 0.58(\pm 0.03)P_2$.

The absolute energy scale was not accurately determined, but relative energies are estimated to be good to ± 10 kev. The targets were about 15 kev thick.

Angular distributions have been measured at the resonances which are labeled in Figs. 12 and 13, and the results are summarized in the figure captions. The Al^{27} angular distribution data have been reported in detail in an earlier paper.⁶