

Longitudinal Polarization of O^{14} Positrons*†

J. C. HOPKINS,‡ J. B. GERHART, F. H. SCHMIDT, AND J. E. STROTH§
Department of Physics, University of Washington, Seattle, Washington

(Received October 3, 1960)

The longitudinal polarization of positrons from the pure Fermi transition of O^{14} has been studied by the method of Bhabha scattering. A prismatic beta-ray spectrometer selected 1.0-Mev positrons which then were focused by a solenoidal magnetic lens on a Supermendur foil magnetized by the lens. Scattered positrons and recoil electrons were detected in fast coincidence. The scattering asymmetry observed upon reversal of the lens magnetic field was $(4.16 \pm 0.80)\%$, which corresponds to positron longitudinal polarization $+ (0.97 \pm 0.19) v/c$.

I. INTRODUCTION

IN 1957 Gerhart *et al.*¹ undertook to measure the longitudinal polarization of positrons emitted in the pure Fermi decay of O^{14} . Two severe experimental problems had to be surmounted: production of sufficiently intense sources of 71-sec O^{14} and elimination of interference from the coincident 2.3-Mev gamma ray following each O^{14} beta decay (see Fig. 1). Because of the energetic gamma ray it was necessary to select positrons with a beta-ray spectrometer, which aggravated the source strength problem. From the beginning, two approaches were considered: (1) measurement of the circular polarization of annihilation-in-flight radiation by scattering from magnetized iron; (2) measurement of Bhabha (positron-electron) scattering in magnetized foils. Preliminary estimates indicated the first approach to be more efficient in using the available O^{14} positrons.² Because of this the first method was used, and an experimental asymmetry in the Compton scattering of annihilation-in-flight quanta of $(1.94 \pm 0.46)\%$ was observed.¹ The interpretation of this asymmetry in terms of longitudinal polarization of the O^{14} positrons was difficult and subject to a variety of calculational problems. The result obtained for the polarization, including *only the statistical error* of the data, was $P = + (0.73 \pm 0.17) v/c$. Because of the unsatisfactory nature of this result we have used the second method, Bhabha scattering, to determine the same polarization.

Bhabha scattering has two advantages over the annihilation-in-flight method. First, and most important, is that the theoretical interpretation of the experimental asymmetry in terms of polarization, though still involving complex numerical computations, is not subject to the uncertainties which arose in the annihilation-in-

flight experiment. Second, the expected experimental asymmetry for maximum positron polarization in the Bhabha scattering experiment is $\sim 4.3\%$ compared to $\sim 2.6\%$ expected in the annihilation-in-flight experiment. In the scattering experiment we find for 1.0-Mev O^{14} positrons an asymmetry of $(4.16 \pm 0.80)\%$, which corresponds to a longitudinal polarization $P = + (0.97 \pm 0.19) v/c$. This result is in full agreement with the predictions of the two-component neutrino theory.³

II. EXPERIMENTAL METHOD

A. Apparatus

Bombardment of N_2 gas with 22-Mev H_2^+ ions from the University of Washington 60-in. cyclotron was used to produce O^{14} by the reaction $N^{14}(p,n)O^{14}$. The activity was chemically purified, converted to water vapor,

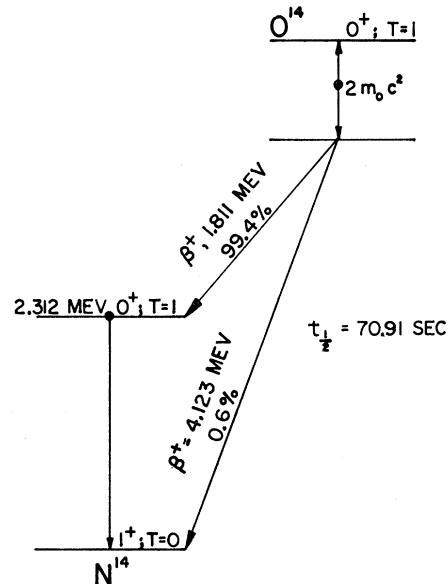

FIG. 1. O^{14} decay scheme. [Data from F. Ajzenberg-Selove and T. Lauritsen, *Nuclear Phys.* **11**, 1 (1959); R. K. Bardin, C. A. Barnes, W. A. Fowler, and P. A. Seeger, *Phys. Rev. Letters*, **5**, 323 (1960); and D. L. Hendrie and J. B. Gerhart, *Phys. Rev.* **121**, 846 (1961).]

³ J. D. Jackson, S. B. Treiman, and H. W. Wyld, *Phys. Rev.* **106**, 517 (1957).

* This work was supported in part by the U. S. Atomic Energy Commission.

† Based in part on a dissertation submitted by J. C. Hopkins to the University of Washington in candidacy for the degree of Doctor of Philosophy.

‡ Now at Los Alamos Scientific Laboratory, Los Alamos, New Mexico.

§ Now at San Jose State College, San Jose, California.

¹ J. B. Gerhart, F. H. Schmidt, H. Bichsel, and J. C. Hopkins, *Phys. Rev.* **114**, 1095 (1959).

² Later experience has shown that to obtain comparable experimental uncertainty in the positron polarization the second approach requires observation of approximately four times as many events as the first approach.

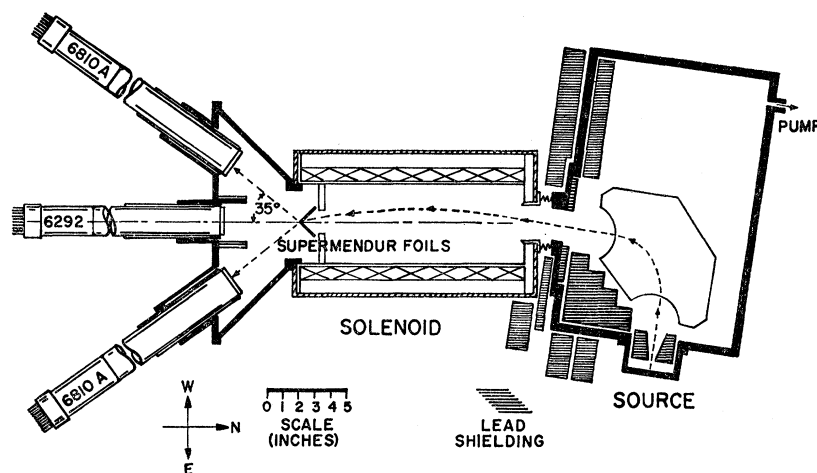

FIG. 2. Bhabha scattering apparatus. The outline of the spectrometer pole face is indicated on the right. The spectrometer vacuum chamber was made large to reduce scattering of gamma rays into the solenoid. On the left are shown the three detectors. The scattering foil is shown rotated about the solenoid axis 90° from its actual orientation.

transported about 100 ft to the experimental apparatus in a continuous flow system, and there frozen onto the end of a copper rod held at liquid nitrogen temperature.⁴ Sources of 7 to 8 mc were used during the experiment which were stable to within 20% for long periods. The O^{15} contamination produced by the $N^{15}(p,n)O^{15}$ reaction on the 0.37% abundant N^{15} in the target gas was determined by observing the decay of positrons in the energy range actually used (1.0 Mev) for Bhabha scattering. It was found that $(9 \pm 4)\%$ of these positrons were from O^{15} rather than O^{14} , an amount which has a negligible effect on our experimental results.⁵

Figure 2 is a schematic diagram of the Bhabha scattering apparatus. Positrons from the source enter the prismatic spectrometer through a 0.0005-in. Mylar window. A lead shutter can be placed in front of this window to determine the effects of source gamma rays. Positrons selected by the spectrometer (17% momentum resolution) are deflected approximately 90° and leave the spectrometer through a 1.5 by 1.5 in. exit window. The positrons then enter a solenoid 15 in. long and 4.75 in. in inside diameter. The solenoid is iron-covered to contain its magnetic field as much as possible and thus to prevent interaction between the solenoid and the spectrometer. The solenoid focuses the positrons on the scattering foil placed just inside the opposite end of the solenoid (Fig. 3). In addition, the solenoid field is used to magnetize the scattering foil. By revers-

ing the solenoid field, the foil magnetization is also reversed and in principle the sense of rotation of the positrons in their orbits, but this does not otherwise affect their distribution at the scattering foil. In practice this is only approximately true because it is not possible to isolate the spectrometer and solenoid fields completely, and because the intensity and velocity distributions of the positrons entering the solenoid are not symmetric about the solenoid axis. Because of these effects the apparatus produces a scattering asymmetry which is instrumental in origin and must be determined experimentally. This instrumental asymmetry is of the same order of magnitude as the true scattering asymmetry.

Two scattering foils are arranged to form a V-shaped trough whose apex lies on the solenoid axis. The foils are inclined, so that their planes make a 30° angle with the solenoid axis. Foils of 0.00019-in. Supermendur⁶ were used for the polarization measurements. To determine the instrumental asymmetry 0.0005-in. aluminum foils were used (these had approximately the same electron density as the Supermendur foils).

Since the O^{14} source was not completely stable, it was necessary to monitor the positron beam. This was done with a plastic scintillator placed on the solenoid axis about 5 in. beyond the scattering foil. Positrons enter the scintillator through a perforated lead shield which passes one-tenth of the positron beam. The scintillator was connected to a DuMont 6292 photomultiplier through a 12-in.-long light guide. In normal operation the monitor counting rate was about 10^4 counts/sec, which corresponds to a beam of 10^5 positrons/sec.

Scattered positrons and recoil electrons are detected in coincidence by two 2-in. by 3.5-in. by $\frac{1}{8}$ -in. plastic scintillators (Fig. 3). The centers of these detectors are at angles of 35° with the solenoid axis. In the central plane of the spectrometer they detect particles scattered

⁴ A more complete description of the O^{14} production system is given in the work cited in footnote 1.

⁵ It is possible to predict the longitudinal polarization that would be observed in a mixture of O^{14} and O^{15} positrons of the same energy (see work cited in footnote 3). Assuming time-reversal invariance, $C_A = C_{A'}$ for the axial vector interaction, and evaluating the nuclear matrix elements for the O^{14} and O^{15} transitions from their respective f_l values and the beta-decay coupling constants, we have calculated the expected longitudinal polarization for a mixture of 91% O^{14} and 9% O^{15} for various values of $\delta = (C_V' - C_V) / C_V$. In this case, the expected longitudinal polarization differs from that expected for O^{14} positrons alone by 0.0% if $\delta = 0$, by 0.7% for $\delta = 0.2$, and by 4.2% for $\delta = 0.5$. Since there is little question that $\delta < 0.5$, it is evident that ignoring the O^{15} in our O^{14} source leads to an error far smaller than the experimental uncertainties.

⁶ We are grateful to Dr. H. L. B. Gould of the Bell Telephone Laboratories, who generously supplied the thin Supermendur foils.

FIG. 3. Schematic drawing showing orientation of scattering foils and detectors. The monitor counter is omitted for clarity.

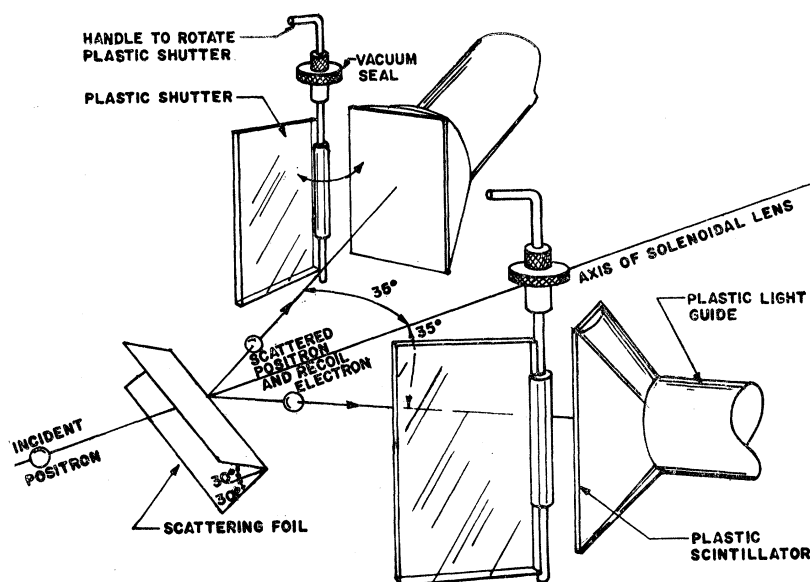

into angles between 25 and 45°. The plastic scintillators were made thin to reduce gamma-ray background but thick enough to stop the approximately 500-keV scattered particles. The two scintillators are connected through 12-in.-long light guides to RCA 6810 A photomultipliers. In normal operation the counting rate of scattered particles in each detector was about 2000 counts/sec. The total coincidence counting rate was 0.6 counts/sec. The gains of the scattered particle counters and the monitor counter are altered by less than 0.04% by reversal of the solenoid field.

Pulses from the scattered particle counters were analyzed in a conventional fast-slow coincidence circuit of resolving time $2\tau \sim 4 \times 10^{-9}$ sec. Pulse height discrimination was used to exclude low-level background and noise.

B. Coincidence Corrections

The observed coincidence counts had to be corrected for a variety of spurious effects. These include accidental coincidences caused by the finite resolving time of the coincidence circuit, extraneous coincidences caused by gamma rays registered by the counters, and coincidences caused by scattering from parts of the apparatus other than the scattering foil. Corrections for these effects were determined experimentally. Accidental coincidences accounted for 4.5% of the total coincidence rate. Beta-gamma and gamma-gamma coincidences between 2.3-MeV O^{14} gamma rays and either scattered positrons or annihilation quanta were determined with thin plastic shutters which could be placed over the scattered particle counters to eliminate positrons but not gamma rays. Beta-gamma coincidences accounted for 6.7% of the total coincidence rate; gamma-gamma coincidences accounted for 3.3% of the total coincidence rate. Spurious beta-beta coincidences were caused by pairs

from the 2.3-MeV O^{14} gamma ray. These coincidences, which accounted for 1.1% of the total coincidence rate, were measured by closing the lead shutter, which prevented positrons from entering the spectrometer. Finally, spurious coincidences could be produced by positrons scattering from the foil support or other parts of the apparatus. These coincidences were measured in the absence of a scattering foil and contributed 6.8% of the total coincidence rate. The correction for all types of spurious coincidences was 22.4%.

C. Instrumental Asymmetry

The spectrometer and lens system used to focus positrons on the scattering foil would introduce no scattering asymmetry if there were no interaction between the spectrometer and the solenoid lens, and the lens had a perfectly uniform magnetic field. In the actual apparatus neither of these requirements was satisfied. The resulting experimental effects are discussed in the following paragraphs.

In order to obtain a sufficiently strong positron beam the spectrometer was operated with poor resolution, and consequently the exit window had to be large. As a result, the positrons entering the lens had different momenta according to the part of the exit window they passed through. Because of the positron spectrum shape the intensity of particles entering the lens also depended on the part of the exit window through which they passed. Furthermore, the large exit window made it impossible to isolate the spectrometer and lens fields completely, so that reversing the lens field affected the distribution of positrons in the spectrometer exit window (Fig. 4).

If the solenoid had a strictly uniform field it would produce at the scattering foil an unmagnified, erect image of the positron distribution in the spectrometer

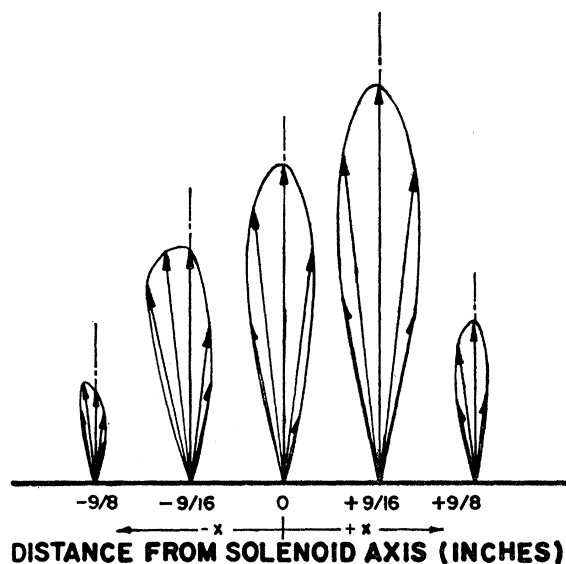

FIG. 4. Relative intensity of positrons in the symmetry plane of the scattering foils. The length of each arrow indicates the relative positron intensity in the direction of the arrow at the position indicated. The change in these distributions when the solenoid field is reversed is not perceptible in this drawing. A Co^{56} source of the same shape as the O^{14} source was used to obtain these data for reasons of experimental convenience. Of course, the actual nuclear source of positrons is of no importance since these data were used only to determine the intensity distributions used in the theoretical calculations discussed in Sec. III.

exit window for either field direction. But the solenoid, which is a thick lens, does not have a perfectly uniform field. As a result, the image of the exit window distribution produced at the scattering foil is rotated through somewhat less than 360° for one solenoid field direction and somewhat more than 360° for the opposite field direction. Because the positron distribution entering the solenoid is not only nonuniform but is also affected by the solenoid field, the rotation on field reversal of the image formed at the scattering foil results in a scattering asymmetry of instrumental origin.

Since the source strength of the 71-sec O^{14} could not be made extremely constant in time, it was necessary to monitor the positron beam. The counter used for this purpose (see Sec. A) could not be made large enough in diameter to intercept all of the positron beam as it diverged from the focus of the solenoid lens. Because of the change in the positron beam distribution on reversal of the solenoid field, this monitor counter also exhibited an asymmetry on field reversal, and correction for this asymmetry was necessary because the monitor count was used to normalize the scattered particle count.

The instrumental asymmetries were determined experimentally by observing the Bhabha scattering from a 0.0005-in. aluminum foil. This thickness of aluminum has approximately the same number of electrons as the Supermendur foil. Consequently, the Bhabha scattering from the two foils is comparable. The nuclear charge of aluminum, however, is substantially less than the

TABLE I. Observed asymmetries.

Aluminum scatterer (0.0005 in.)	
Scattering asymmetry	$-1.36 \pm 0.58\%$
Monitor asymmetry	$+0.81 \pm 0.31\%$
Net instrumental scattering asymmetry	$-2.17 \pm 0.66\%$
Supermendur scatterer (0.00019 in.)	
Scattering asymmetry	$+1.00 \pm 0.34\%$
Monitor asymmetry	$-0.99 \pm 0.30\%$
Net instrumental and polarization asymmetry	$+1.99 \pm 0.45\%$
Net polarization asymmetry	$+4.16 \pm 0.80\%$

average nuclear charge for Supermendur, and thus the Rutherford scattering from the two foils is quite different. This difference, plus the fact that the magnetic field disturbance caused by the Supermendur foil affects the orbits of particles reaching the monitor counter, caused the monitor asymmetries for the two scatterers to differ. Consequently, the monitor asymmetry had to be determined separately for each scatterer. The observed asymmetries⁷ are shown in Table I along with the net asymmetry attributable to the positron polarization.

D. Data

Experimental data for Bhabha scattering of O^{14} positrons were obtained in a single 120-hr cyclotron run. Our procedure was to accumulate data with one solenoid field direction for 30 min, and then for another 30 min with the opposite field direction. After each such pair of measurements two 1-min counts were made, one for each field direction. In each 1-min count the scattered particle counters were shielded from positrons and registered only gamma rays. The data for the 30-min counts were normalized with the monitor count and analyzed for asymmetry in the manner described in the work cited in footnote 1. The monitor data for the 1-min counts were analyzed to determine the monitor asymmetry. The corrections for beta-gamma and gamma-gamma coincidences were determined in separate counts.

A total of 55 000 coincidences were observed for scattering from aluminum, half before and half after the coincidences observed with the Supermendur scatterer. A total of 105 000 coincidences were observed with the Supermendur scatterer. The asymmetries deduced from the two sets of aluminum data were the same within statistical uncertainties. The asymmetry determinations are summarized in Table I.

III. POSITRON LONGITUDINAL POLARIZATION

The expected scattering asymmetry A for positrons of a given direction and momentum which strike a

⁷ We define asymmetry so that its limiting values are $\pm 100\%$; that is, in the same way that polarization is customarily defined. Asymmetry defined in this manner is half that used by some workers.

specified part of the scattering foil and scatter in a given direction can be expressed in the form $A = fP(\cos\eta) \times [(1-\epsilon)/(1+\epsilon)]$, where f is the fraction of target electrons which are polarized, P is the positron longitudinal polarization, η is the angle between the directions of positron and electron polarization, and $\epsilon = (\sigma_p/\sigma_a)$ is the ratio of the Bhabha scattering cross section for parallel spins to that for antiparallel spins. In applying this formula we assumed that $\cos\eta$ is constant for all positron energies, directions, and scattering sites. This is equivalent to assuming that the positrons striking the scattering foil are perfectly collimated, an assumption which is valid to an accuracy much greater than the statistical uncertainty of the data. We did take into account the experimentally determined distribution of positrons and incident positron directions at the scattering foil (see Fig. 4) and the finite size of the detectors by appropriate numerical integrations. For this purpose we used the expressions for the Bhabha scattering cross section for unpolarized particles given by Ford and Mullins⁸ and the expression for ϵ given by Bincer.⁹ No allowance was made for the negligible effect of energy inhomogeneity of the 1.0-Mev positron beam.

The magnetization of the Supermendur foil was determined by measuring H and using the B - H curves for Supermendur given by Gould and Wenny.¹⁰ From the electron density of Supermendur (taking into account its chemical composition) and the electron magnetic moment, f was then calculated. We found $f = 0.092 \pm 0.001$. This figure should be corrected for the contribution of the orbital motion of the electrons to the magnetization. This correction is known¹¹ for both iron and Deltamax to be about 5%, but it is not known for Supermendur. We have omitted any corrections.

Our calculations give for the expected asymmetry in Bhabha scattering $A = +(0.0455 \pm 0.0024)P$. This, combined with our experimental value, $A = +0.0416 \pm 0.0080$, gives for the longitudinal polarization of 1-Mev O¹⁴ positrons $P = +0.916 = +(0.97 \pm 0.19)(v/c)$.

IV. DISCUSSION

In Table II we have summarized the principal measurements of longitudinal polarization for positrons from pure Fermi allowed transitions. The measurements of

TABLE II. Experimental positron longitudinal polarization in pure Fermi allowed transitions.

Parent	Polarization/(v/c)	Reference
Cl ³⁴	+0.64±0.39	a
	+1.23±0.40	b
Ga ⁶⁶	+0.95±0.12	a
	+1.11±0.37	b
	+1.00±0.16	a
O ¹⁴	+0.73±0.17	c
	+0.97±0.19	present work

^a M. Deutsch, B. Gittelman, R. W. Bauer, L. Grodzins, and A. W. Sunyar, Phys. Rev. **107**, 1733 (1957), with thick absorber.

^b M. Deutsch *et al.*, with thin absorber.

^c J. B. Gerhart, F. H. Schmidt, H. Bichsel, and J. C. Hopkins, Phys. Rev. **114**, 1095 (1959).

Deutsch *et al.*¹² were made by observing the absorption of annihilation-in-flight radiation in magnetized iron, the various values corresponding to measurements at different positron energies and with different thicknesses of iron absorbers. The first measurement for O¹⁴ was made by observing the Compton scattering of annihilation-in-flight radiation from magnetized iron.¹ The error quoted in this case represents statistical uncertainty only and does not include any allowance for systematic error. We believe that the low polarization value, 0.73 (v/c), is a result of our inability to take into account completely the effects of strong multiple scattering. It is also possible that the low value could have resulted in part from a small misalignment of the cylindrical iron analyzer with the incident positron direction.

As discussed earlier, the Bhabha scattering method of determining longitudinal polarization has two significant advantages over our earlier method. First, the expected asymmetry is nearly twice as large; and second, the calculation of the relationship between scattering asymmetry and polarization involves only geometric factors and the Bhabha scattering cross section.

Our results are in full agreement with the predictions of the two-component neutrino theory.

ACKNOWLEDGMENTS

The authors are indebted to H. Nutley, A. J. Lieber, and W. A. Kolasinski for assistance in the experimental work, and to W. Wong for devising and executing digital computer routines used in the theoretical calculations. They are grateful to Professor E. M. Henley and Professor H. B. Silsbee for valuable discussions during the course of the work.

¹² M. Deutsch, B. Gittelman, R. W. Bauer, L. Grodzins, and A. W. Sunyar, Phys. Rev. **107**, 1733 (1957).

⁸ G. W. Ford and C. J. Mullins, Phys. Rev. **108**, 477 (1957).

⁹ A. M. Bincer, Phys. Rev. **107**, 1434 (1957). The expression for ϵ given in this reference is for the case in which the positron and electron are distinguished. It must be modified appropriately when applied to experimental results like ours, where positrons and electrons are not distinguished.

¹⁰ H. L. B. Gould and D. H. Wenny, Elec. Eng. **76**, 208 (1957).

¹¹ P. Argryes and C. Kittel, Acta Met. **1**, 241 (1953).