

Absorption Spectra of F_2^- , Cl_2^- , Br_2^- , and I_2^- in the Alkali Halides*

C. J. DELBECQ, W. HAYES,[†] AND P. H. YUSTER
Argonne National Laboratory, Argonne, Illinois

(Received October 12, 1960)

After x-ray irradiation at liquid nitrogen temperature, holes are trapped by forming F_2^- molecule ions in LiF; Br_2^- molecule ions in KBr containing one of the impurities Ag^+ , Tl^+ , Pb^{++} , or NO_2^- ; and I_2^- molecule ions in KI containing one of the impurities listed above. An investigation of the optical and paramagnetic resonance spectra of crystals containing F_2^- , Br_2^- , and I_2^- centers leads to an identification of the optical transitions of these centers. The polarizations and relative intensities of the optical absorptions in the X_2^- molecule ion series are discussed with reference to the energy level scheme to be expected for such a species.

INTRODUCTION

CASTNER and Känzig¹ have given a detailed description of paramagnetic resonance spectra in x-ray irradiated crystals of LiF, KCl, and KBr which they have attributed to the species F_2^- , Cl_2^- , and Br_2^- , respectively. Delbecq, Smaller, and Yuster² have identified the optical absorption of Cl_2^- in KCl by correlating the changes produced in the optical and paramagnetic resonance spectra after bleaching with polarized light. They also showed that certain impurities when added to potassium chloride act as electron traps and thus increase the rate of formation of Cl_2^- by as much as a factor of 1000.

The present work³ was undertaken to identify the optical absorption of F_2^- , Br_2^- , and I_2^- in LiF, KBr, and KI, respectively.^{4,5} The methods used for this identification are essentially those described in the earlier work.²

EXPERIMENTAL PROCEDURES

The x-band electron spin resonance system used is the same as that described previously.²

All the crystals used in these experiments were grown in this laboratory using the Kyropoulos method. Various impurities (Ag^+ , Pb^{++} , NO_2^- , or Tl^+) were added to the melt before growth so that the single crystals which were used contained about 0.1 mole % impurity. In the one instance of LiF, no impurity was intentionally added. In general, the crystals used for optical absorp-

tion measurements were 12×7 mm in cross section and varied from 0.5 to 15 mm in thickness. The crystals used for electron spin resonance measurements were $2.5 \times 2.5 \times 10$ mm. Color centers were produced by x-ray irradiation from a Machlett tube with tungsten target operating at 50 kv and 50 ma, and filtered through 1 mm of quartz, or by γ -ray irradiation from a 4000-C Co⁶⁰ source.

Polarized light was obtained by using an Ahrens prism which was mounted on the Dewar flask used to hold the crystal. Absorption spectra were taken on either a model 11 or model 14R Cary spectrophotometer using, in general, polarized light with electric vector oriented parallel to $[0\bar{1}1]$ or $[011]$ ⁶; the light from the monochromator passed through the polarizing prism and then through the crystal to the detector. An AH-6 lamp with appropriate filters, or a Bausch and Lomb monochromator in conjunction with a filament lamp, was used as a light source in the bleaching experiments.

The general scheme for the identification of the optical spectra associated with the various X_2^- molecule ions was similar to that used previously² and was as follows:

(a) A crystal containing the desired impurity ions was exposed to either γ - or x-ray irradiation at low temperatures.

(b) Both the optical and paramagnetic resonance absorptions introduced into the crystal by the irradiation were determined.

(c) Correlations were made between the changes produced in the optical and paramagnetic resonance absorption by bleaching with polarized light of a suitable wavelength.

(d) The anisotropies produced in the optical absorption of the crystal by bleaching were determined.

Previous work¹ has shown that the X_2^- molecule ions formed after γ - or x-ray irradiation have their molecular axes aligned along the $\langle 110 \rangle$ directions in the crystal and are equally distributed among the six distinguish-

⁶ Subsequently the term " $[0\bar{1}1]$ light" will be used to indicate light with electric vector parallel to $[0\bar{1}1]$ and with propagation vector parallel to $[100]$, and the term " $[100]$ light" will be used to indicate light with electric vector parallel to $[100]$ and with propagation vector parallel to $[010]$. These directions are related to the crystal axes (Fig. 1).

* Based on work performed under the auspices of the U. S. Atomic Energy Commission.

[†] Now at the Clarendon Laboratory, Oxford, England.

¹ T. G. Castner and W. Känzig, *J. Phys. Chem. Solids* **3**, 178 (1957).

² C. J. Delbecq, B. Smaller, and P. H. Yuster, *Phys. Rev.* **111**, 1235 (1958).

³ C. J. Delbecq, B. Smaller, and P. H. Yuster, *Bull. Am. Phys. Soc., Ser. II* **2**, 343 (1957).

⁴ L. I. Grossweiner and M. S. Matheson, in *J. Chem. Phys.* **23**, 2443 (1955) have observed the absorption spectra of transient species from the photolysis of alkali chloride, bromide, and iodide solutions, and have suggested that these species are the X_2^- ions. The positions of the principal peaks in their absorption spectra correspond quite well to the short-wavelength peaks reported here for the X_2^- molecule ions.

⁵ Concurrent to the work reported in this paper H. N. Hersh, *J. Chem. Phys.* **31**, 909 (1959) has studied the optical absorption of halogen centers in KBr-Tl and KI-Tl.

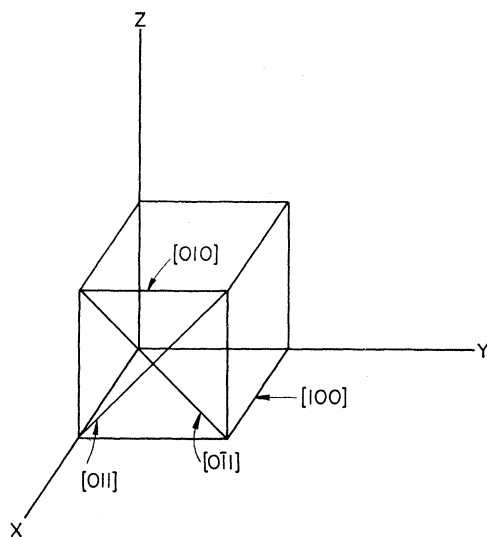

Fig. 1. The orientations of the propagation and electric vectors used in obtaining the $[011]$, $[011]$, and $[100]'$ spectra.

able orientations. Consequently, before bleaching, the optical absorption spectra taken with either $[011]$ or $[011]$ polarized light are identical. After bleaching with $[011]$ polarized light, the absorption becomes anisotropic and the intensities of the spectra taken with $[011]$ and $[011]$ light are not equal. If the $[011]$ absorption is subtracted from the $[011]$ absorption, a difference curve is obtained which is the anisotropic absorption⁷ produced in the crystal by the bleach; this subtraction eliminates all other absorptions which do not show anisotropy. The degree of anisotropy of the transitions will be indicated by $\lambda_1\alpha\lambda_2$, where α is the ratio of the intensity of the $[011]$ spectrum to that of the $[011]$ spectrum, λ_1 is the wavelength of the bleaching light, and λ_2 is the wavelength at which the ratio is measured.

It has been possible, in cases where it is reasonably certain that no underlying absorption is present due to other species, not only to measure α values, but to obtain additional information on absorption bands at wavelengths longer than $600\text{ m}\mu$. The procedure has been to orient the centers to the maximum degree possible by bleaching in the short wavelength anisotropic band with $[011]$ light. To a first approximation⁸ the molecular axes of the X_2^- are all oriented in the $[011]$ direction, and thus spectra taken with $[011]$ light, $[011]$ light, and $[100]'$ light will indicate the anisotropy of the transition. In the case of the more anisotropic transitions such absorption spectra are not presented, since they would tend to be misleading. The

⁷ This constitutes a definition of anisotropic absorption as used in this paper.

⁸ It has not been possible, by bleaching with polarized light, to obtain a crystal in which more than 90% of the X_2^- molecule ions are oriented in a single direction. An equilibrium distribution is obtained which may be determined partly by depolarization of the light by strains in the crystal and partly by incomplete anisotropy of the ultraviolet transitions.

reason is that the low-intensity $[011]$ and $[100]'$ spectra may consist, to a large degree, of a transition of another species, or of the absorption of a small residual fraction of X_2^- with molecular axes making an angle of 60° with $[011]$, rather than the absorption of the very large fraction of X_2^- oriented along $[011]$. In order to observe some of the weak, long-wavelength transitions of the X_2^- molecule ions it has been convenient to use heavily irradiated thick crystals in conjunction with a special slidewire attachment for the Cary spectrophotometer with which a full-scale deflection corresponds to 0.1 optical density units instead of the usual 1.0.

EXPERIMENTAL RESULTS

F_2^-

Curve (a) in Fig. 2 shows the optical absorption introduced into a LiF crystal after x-ray irradiation at liquid nitrogen temperature; measurements were made with either $[011]$ or $[011]$ light. The paramagnetic resonance of a LiF crystal treated in a similar fashion is shown in Fig. 3(a). This spectrum was taken with the external magnetic field parallel to $[011]$; thus the field makes angles of 0 , 60 , and 90° with the molecular axes of F_2^- . The hyperfine interaction with the fluorine nuclei is anisotropic and three different species can be identified in the spectrum; the two outer lines belong to the 0° set, the next two lines to the 60° set, and the two lines to the low-field side of the center line belong to the 90° set. The center line is a superposition of unresolved lines from the 60° and 90° sets; the weak, partly resolved line

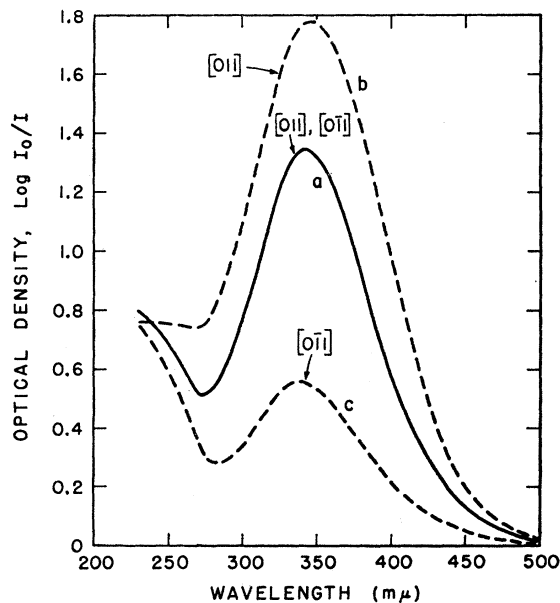

Fig. 2. Absorption spectra of a LiF crystal 6 mm thick (a) after 30 min irradiation with x rays at -196°C measured with either $[011]$ or $[011]$ light; then after bleaching at -196°C for 1 hr with $[011]$ light from an AH-6 lamp in conjunction with a $405\text{-m}\mu$ interference filter and Corning filters 4308 and 7380 as measured with (b) $[011]$ light, and (c) $[011]$ light.

on the high-field side of the strong center line belongs to the 0° set.⁹

If the irradiated crystal is exposed to [011] light of wavelength 405 mμ at 77°K, the distribution of centers among the ⟨110⟩ directions is altered. The change produced in the optical absorption is shown by curves (b) and (c) of Fig. 2. Curve (b) shows that an increase in absorption has occurred when measured with [011] light, while curve (c) shows that a decrease has occurred when measured with [011] light. Curve (b) of Fig. 3 shows the change in the resonance spectrum after bleaching with [011] light. The 0° set has increased in intensity, while both the 90 and 60° sets have decreased considerably; this result clearly demonstrates that there has been a reorientation of F₂⁻ centers into the [011] direction. Consequently, it is concluded that the 348-mμ band arises from an electronic transition of F₂⁻ centers,

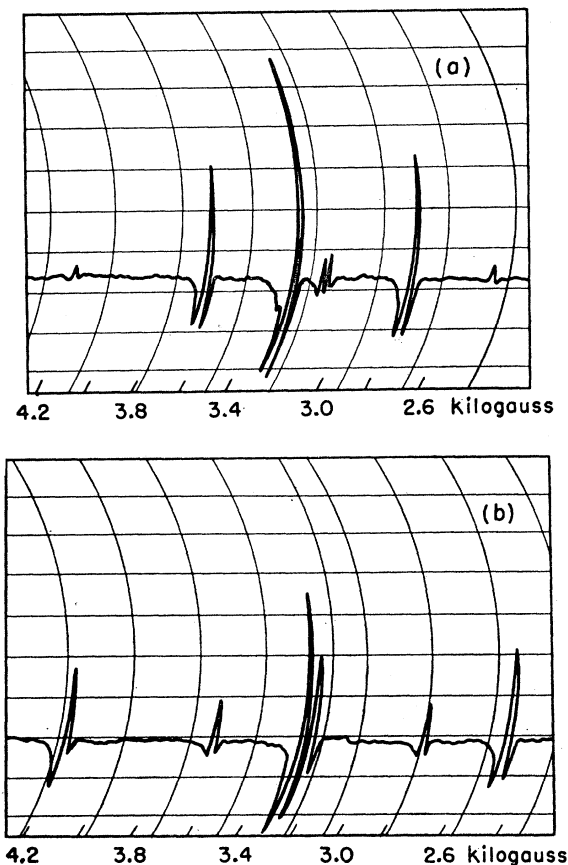

FIG. 3. Second derivative of the absorption lines of the electron spin resonance spectrum, measured at -196°C with the external magnetic field in the [011] direction, of a LiF crystal which had been (a) x rayed for 30 min at -196°C, and (b) subsequently bleached with [011] light at 405 mμ as described in Fig. 2.

⁹ For a detailed description of the paramagnetic resonance absorption of F₂⁻ in LiF, see T. O. Woodruff and W. Känzig, J. Phys. Chem. Solids 5, 268 (1958).

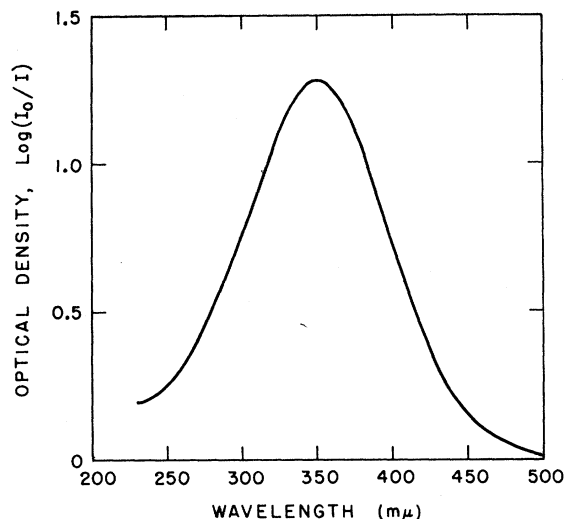

FIG. 4. The anisotropic absorption of the F₂⁻ center obtained by subtracting curve (c) of Fig. 2 from curve (b) of Fig. 2.

that this transition is σ -polarized,¹⁰ and that excited F₂⁻ centers can reorient.

Figure 4 shows the absorption obtained by subtraction of curve (c) of Fig. 2 from curve (b). This difference curve with peak at 348 mμ is the anisotropic part of the F₂⁻ absorption. The following experiments prove that F₂⁻ has another absorption band at about 750 mμ, which shows very little anisotropy. (1) A sample is bleached with polarized light until it gives a spectrum as shown in curves (b) and (c) of Fig. 2, and then is exposed to light in the 750-mμ region. The anisotropy which is developed by the 405-mμ bleach is essentially destroyed, indicating that the band in the red is to be associated with F₂⁻. The band is so weak that the optical absorption cannot be directly measured; however, its peak position is determined to be approximately 750 mμ by the rate of disappearance of the anisotropy of the 348-mμ band as a function of the wavelength of bleaching light. (2) In another type of experiment, the x-ray irradiated crystal is first bleached with polarized light in the 750-mμ region and then examined in the 348-mμ region. The results of the latter experiments (see Table I) show that the transition responsible for the 750-mμ absorption is almost isotropic but with a slight π_1 and π_2 polarization.

X-ray irradiation of supposedly pure LiF at low temperature results in a rate of formation of F₂⁻ which is much greater than that for X₂⁻ ions in other pure alkali halides. Other work,^{2,3} and work described later in this paper, has shown that certain impurities in the alkali chlorides, bromides, and iodides act as electron traps

¹⁰ A σ -polarized transition is one that is permitted for light with electric vector parallel to the molecular axis, while π -polarized transitions are allowed for light with electric vector perpendicular to the molecular axis. Because of the orthorhombic symmetry of the X₂⁻ centers,¹ there are two inequivalent and mutually perpendicular directions for π and we define π_1 to be parallel to ⟨110⟩ and π_2 to be parallel to ⟨100⟩.

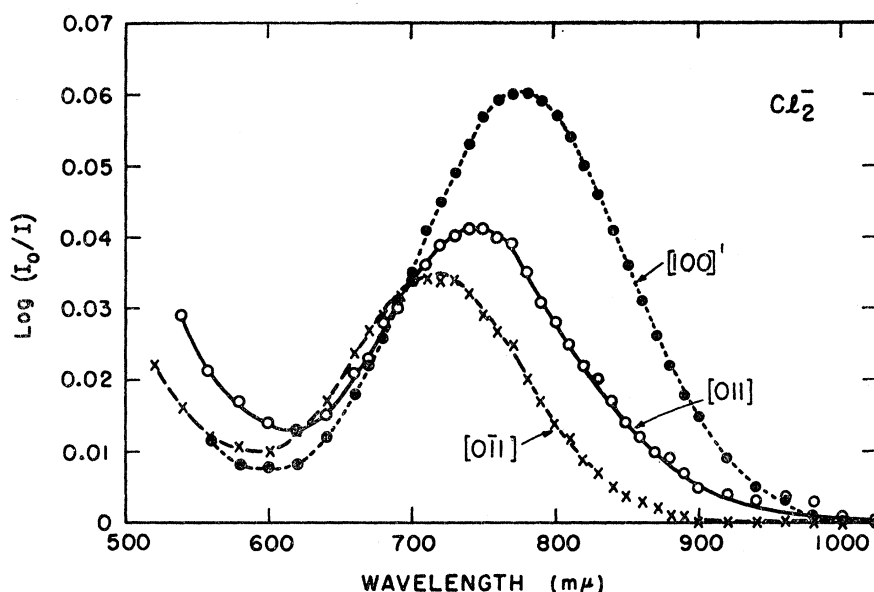

FIG. 5. The $[011]$, $[0\bar{1}1]$, and $[100]'$ spectra of the Cl_2^- 750- $m\mu$ band.

and enhance the rate of formation of X_2^- upon x irradiation at low temperature. Consequently it is concluded that either the LiF used must contain, before the irradiation, some readily available electron trap in the form of a chemical impurity or a lattice imperfection, or some process is operative in LiF for trapping electrons which is not operative in the other alkali halides.

Cl_2^-

The identification and some of the properties of the Cl_2^- optical transitions have been described previously.² Table I shows the α values for bleaching in the 365- and 750- $m\mu$ bands. Although the 750- $m\mu$ band is relatively isotropic, the α value shows that it is not completely so. A more detailed study of the anisotropy of this absorption was made by studying the $[011]$, $[0\bar{1}1]$, and $[100]'$ spectra. The Cl_2^- centers, in a KCl-NO_2^- crystal which had been exposed to Co^{60} γ rays at liquid nitrogen temperature, were oriented into the $[011]$ direction by bleaching with $[0\bar{1}1]$ light at 436 $m\mu$. Figure 5 shows the $[011]$, $[0\bar{1}1]$, and $[100]'$ spectra of such a crystal; the thickness of the crystal is the same for all three spectra so that the differences in intensity reflect differences in oscillator strength. The ratios of the intensities of these three absorptions remain essentially constant on going to liquid helium temperature, and very little change occurs in the half-widths and peak positions.

Br_2^-

Experiments similar to those on LiF and KCl were carried out on potassium bromide crystals containing the impurities Pb^{++} , Ag^+ , and NO_2^- . The added impurity has no effect on the characteristics of the paramagnetic resonance spectrum or the anisotropic optical absorption of Br_2^- . Correlation of the changes in the

optical absorption and paramagnetic resonance absorption spectra upon bleaching with polarized light indicates that the anisotropic part of the Br_2^- absorption is that shown in Fig. 6 and is σ -polarized.

The same absorption spectrum as that shown in Fig. 6 can be obtained for Br_2^- whether one bleaches with polarized light of wavelength 470 $m\mu$ or 750 $m\mu$. The wavelength 470 $m\mu$ is chosen as optimum to avoid bleaching the trapped electron which absorbs in the 385- $m\mu$ region. However, one can obtain a greater degree of preferential orientation by bleaching in the short wavelength band than in the 750- $m\mu$ band. The following experiment demonstrates this fact. A crystal containing Br_2^- was bleached with $[0\bar{1}1]$ light of wavelength 470 $m\mu$ until the ratio of the $[011]$ absorption to the $[0\bar{1}1]$ absorption became constant; the value reached was ${}^{470}\alpha_{750} = 6.6$. Subsequently, the crystal was bleached with $[011]$ light of wavelength 750 $m\mu$ until a constant ratio was again established. It was found that the latter bleach causes a disorientation of Br_2^- , and that ${}^{750}\alpha_{750} = 3.2$. It follows that the short-wavelength transition has a greater ratio of σ to π_1 polarization than the 750- $m\mu$ transition. Similar experiments show that π_1 and π_2 make approximately equal contributions to this absorption.

Figure 7 shows the long-wavelength absorption band of Br_2^- in KBr-NO_2^- taken with unpolarized light. These results were obtained on a crystal 12 mm thick which had been exposed to Co^{60} γ rays. Because of the thickness of the crystal and the high color center density, details can be seen in the 750- $m\mu$ absorption which were not obvious before. The rather pronounced long-wavelength tail indicates that this absorption consists of two unresolved bands, the large band at 750 $m\mu$ and a weak band near 900 $m\mu$. The existence of these two transitions is further indicated by the fact that when

TABLE I. Disorientation temperatures and characteristics of optical absorption bands of X₂⁻ ions.

X ₂ ⁻	Matrix	Disorientation temperature (T _D)	Peak position in absorption spectrum		Relative integrated area of transition	Excited state of transition	λ ₁ αλ ₂	Half-width, ev
			mμ	ev				
F ₂ ⁻	LiF	-160°C	348	(3.65)	>200 1	² Σ _g ⁺ ² Π _g ³	⁴⁰⁵ α ₃₈₀ = 20 ⁷⁵⁰ α ₃₄₀ = 0.95	1.20
			~750	(1.65)				
Cl ₂ ⁻	KCl	-100°C	365	(3.40)	100 1	Σ _g ⁺ Π _g ³	⁴⁸⁶ α ₄₀₀ = 25 ⁷⁵⁰ α ₃₆₅ = 1.25	0.81
			750	(1.65)				0.37
Br ₂ ⁻	KBr	-130°C	385	(3.22)	445 9.5 1	Σ _g ⁺ Π _g ³ Π _g ³	⁴⁷⁰ α ₇₅₀ = 6.6 ⁷⁵⁰ α ₇₅₀ = 3.2 ⁹⁰⁰ α ₇₅₀ = 1.8	0.73
			750	(1.65)				0.26
			~900	(1.38)				
I ₂ ⁻	KI	-180°C	400	(3.10)	340 56 1	Σ _g ⁺ Π _u (?) Π _g ³ Π _g ³	⁴⁰⁵ α ₈₀₀ = 17 ⁸⁰⁰ α ₈₀₀ = 8.5 ¹¹⁵⁰ α ₈₀₀ = 1.2	0.55
			585	(2.12)				0.36
			800	(1.55)				0.22
			1150	(1.08)				0.19

bleached with [011] light at 900 mμ, ⁹⁰⁰α₇₅₀ = 1.8. The λ_{α750} values for λ lying on the short-wavelength side of the 750-mμ band are constant at 3.2; we assume that these values remain constant for this transition on the long-wavelength side of the 750-mμ band, and therefore conclude that the amount of σ polarization is considerably smaller for the 900-mμ transition than for the 750-mμ transition. Further experiments show that π₂ is more intense than either σ or π₁.

I₂⁻

Crystals of KI containing Tl⁺, NO₂⁻, or Ag⁺ show an extensive anisotropic electron spin resonance spectrum after x irradiation at liquid nitrogen temperature; because of the complexity of the spectrum, it has not been found possible to assign any of the observed lines to I₂⁻. However, the positions and polarization properties of the optical absorption bands and their relative intensities fit quite well into the pattern of X₂⁻ as established by F₂⁻, Cl₂⁻, and Br₂⁻. It is this correlation with the corresponding optical data in the other X₂⁻ molecules which leads us to believe that I₂⁻ is present in these crystals. The inability to identify the resonance spectrum of I₂⁻ may be due in part to large second-order effects or to a distortion of the center, which complicate the hfs, or to the presence of lines from other unidentified centers.

Figure 8 shows the anisotropic part of the I₂⁻ optical spectrum in a crystal of KI-NO₂⁻.¹¹ The 800-mμ band in the absorption spectrum of I₂⁻ is very prominent and shows polarization properties which are similar to those of the 400-mμ band. In experiments similar to those described above for Br₂⁻, it is found that ⁴⁰⁵α₈₀₀ = 16 and ⁸⁰⁰α₈₀₀ = 8.5. Figure 9 shows the absorption of I₂⁻ in a thick KI-NO₂⁻ crystal (4 mm) which had been exposed to Co⁶⁰ γ rays; since there are more centers in this crystal more detail can be seen in the absorption spec-

trum, and in addition to the 800-mμ band a weak band is seen at 1150 mμ. Bleaching in the 1150-mμ band with [011] light causes only a small anisotropy in the 800-mμ band (see Table I). However, an experiment similar to those used to identify the 750-mμ bands of F₂⁻ and Cl₂⁻ clearly indicates that the 1150-mμ band belongs to the I₂⁻ center. The [011], [011], and [100]' spectra for the 1150-mμ band of I₂⁻ centers show this absorption to be nearly isotropic, with little change upon cooling to liquid helium temperature.

In addition to the transitions at 400, 800, and 1150 mμ, there is another approximately isotropic I₂⁻ transition at 585 mμ. This band at 585 mμ appears only as a hump on the long-wavelength side of the 400-mμ band in a crystal containing equal populations of I₂⁻ in the six <110> directions. However, orientation of the I₂⁻ centers into the [011] direction allows a closer examination of the 585-mμ band in the [011] spectrum, since here the very anisotropic 400-mμ band is present only to a slight extent, and there is only a little interference from an absorption which appears to be the result of

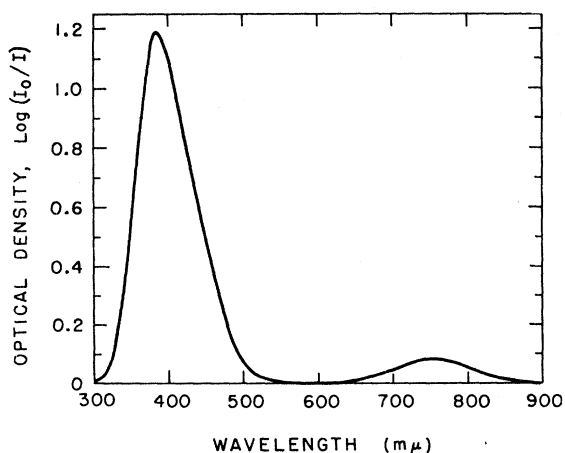

FIG. 6. The anisotropic absorption of the Br₂⁻ center in KBr-NO₂⁻.

¹¹ All optical experiments were carried out at the nitrogen triple point unless otherwise noted.

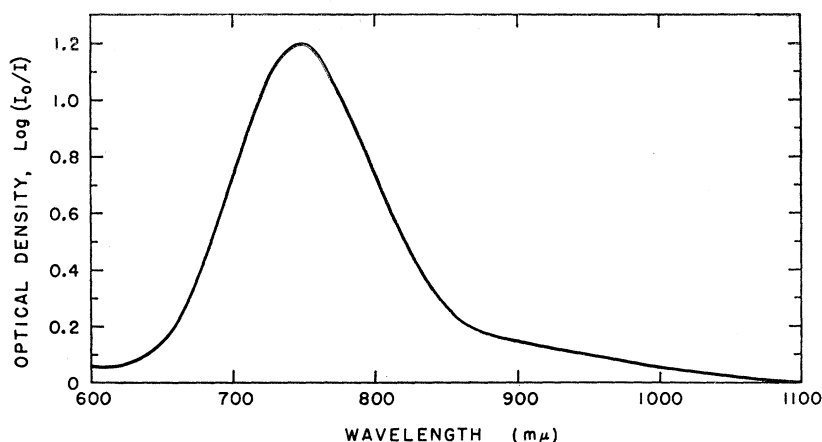

FIG. 7. The absorption introduced into a 12-mm-thick KBr-NO_2^- crystal after exposure at -196°C for 8 min to the Co^{60} γ -ray source.

electron excess centers. The proof that this transition belongs to the I_2^- center is very similar to that used in the case of the Br_2^- 900- $\text{m}\mu$ band; i.e., upon bleaching with $[011]$ light one finds that ${}^{560}\alpha_{800} = 2$ and that $\lambda\alpha_{800}$ increases as λ decreases toward the peak of the 400- $\text{m}\mu$ band. It is assumed that the anisotropy of the I_2^- 400- $\text{m}\mu$ band remains constant through the whole band. Consequently it is concluded that the nearly isotropic band at 585 $\text{m}\mu$ is a transition of the I_2^- center.

As described in the foregoing, in the experimental results, the shape of the X_2^- absorption band to the first approximation is obtained by measuring the anisotropic absorption in the polarized light experiments. That this procedure is not entirely correct is clear when one considers that any isotropic absorption associated with X_2^- would remain undetected. Also, the relative strengths of the absorptions given in Table I are not completely correct. For example, these data on the relative intensities of the 400- and 800- $\text{m}\mu$ I_2^- bands were obtained from the anisotropic absorption of Fig. 8; whereas the relative intensities of the 800- and 1150- $\text{m}\mu$ I_2^- bands were obtained from Fig. 9. Since we have shown that the long-wavelength absorption in each case is less anisotropic, the true ratio measured with nonpolarized light would be somewhat smaller because the subtraction method favors the most anisotropic absorption. It will be noted that the α values for the short-wavelength transition are measured in the long-wavelength tail of the ultraviolet band or in the long-wavelength band; the reason is that a rather sizeable isotropic absorption underlies the short-wavelength band and results in obviously low values of α . From the table it is apparent that the short-wavelength transition is the more anisotropic of the two; therefore, the short-wavelength transitions of Br_2^- and I_2^- are more anisotropic than a cursory glance at Table I would indicate.

DISORIENTATION TEMPERATURES

F_2^- , Cl_2^- , and Br_2^- in the crystals studied show no appreciable mobility at liquid nitrogen temperature, and therefore any anisotropy which is introduced into

the absorption will persist for an indefinite period at this temperature. However, I_2^- in KI is considerably more mobile and the anisotropy only lasts a short time at liquid nitrogen temperature. It was found that the anisotropy persists at the triple point of nitrogen; consequently all polarization experiments reported here for KI, except those noted otherwise, were run at this temperature.

The temperature at which the X_2^- molecule ions disorient in the lattice (previously^{2,12} described as the re-orientation temperature) was determined in the following way. After the X_2^- molecule ions were preferentially oriented by bleaching with polarized light, the anisotropy was followed as a function of temperature using a pulse annealing technique. The sample was warmed rapidly to a given temperature, held there for 2 min, cooled to liquid nitrogen temperature, and the anisotropic absorption remeasured. This procedure was repeated at successively higher temperatures. The anisotropic absorption was plotted against annealing temperature and the point of maximum rate of change in the anisotropic absorption was defined as the disorientation temperature T_D . Table I shows the disorientation temperatures for all the X_2^- molecule ions studied. Since T_D is expected to be a marked function of the base crystal and the binding energy of the X_2^- ion, it would appear to be difficult to account satisfactorily even for the observed trends in T_D .

DISCUSSION

Optical transitions of X_2^- molecule ions in the free state have not been observed, but the spectra of the neutral halogen molecules have been discussed in detail by Mulliken.¹³ In agreement with previous authors,^{14,15} we shall assume that the ground state of X_2^- is $\sigma_g^2\pi_u^4\pi_g^4\sigma_u^4({}^2\Sigma_u^+)$. Electric dipole transitions are

¹² W. Hayes and G. Nichols, *Phys. Rev.* **117**, 993 (1960).

¹³ R. S. Mulliken, *Phys. Rev.* **57**, 500 (1940).

¹⁴ M. H. Cohen, *Phys. Rev.* **101**, 1432 (1956).

¹⁵ T. Inui, S. Harasawa, and Y. Obata, *J. Phys. Soc. Japan* **11**, 612 (1956).

allowed from the ground state to the excited states $\sigma_g^2\pi_u^4\pi_g^3\sigma_u^2(^2\Pi_g)$ and $\sigma_g\pi_u^4\pi_g^4\sigma_u^2(^2\Sigma_g^+)$. The transition to the state $\sigma_g^2\pi_u^3\pi_g^4\sigma_u^2(^2\Pi_u)$ is forbidden. Departures from axial symmetry in the crystal will raise the degeneracy inherent in the π levels, but this effect is expected to be small¹ and will be neglected in the preliminary discussion: The transition $^2\Sigma_u^+ \rightarrow ^2\Sigma_g^+$ is a sub-Rydberg transition of the charge-transfer type¹⁶ and is expected to be strong; it is allowed for σ -polarized light. The transitions $^2\Sigma_u^+ \rightarrow ^2\Pi_{g3/2}$ and $^2\Sigma_u^+ \rightarrow ^2\Pi_{g3/2}$ are allowed for π -polarized light and should be considerably weaker.

The strong σ -polarized transitions observed for all the X₂⁻ ions in the ultraviolet are assigned to the $^2\Sigma_u^+ \rightarrow ^2\Sigma_g^+$ transition. The weaker transitions of Br₂⁻ and I₂⁻ observed in the red and infrared may be assigned to $^2\Sigma_u^+ \rightarrow ^2\Pi_{g3/2}$ and $^2\Sigma_u^+ \rightarrow ^2\Pi_{g3/2}$, respectively. The observed increase in the spacing of these weak transitions with increasing atomic weight arises from the increased spin-orbit coupling in the halogen atoms. The transition $^2\Sigma_u^+ \rightarrow ^2\Pi_{g3/2}$ contains more σ polarization in I₂⁻ than in Br₂⁻, the only cases where the $^2\Sigma_u^+ \rightarrow ^2\Pi_{g3/2}$ and $^2\Sigma_u^+ \rightarrow ^2\Pi_{g3/2}$ transitions are resolved. The $^2\Sigma_u^+ \rightarrow ^2\Pi_{g3/2}$ transition also increases in intensity relative to the ultraviolet transition through the series F₂⁻ to I₂⁻. These effects may arise from an admixture of Σ_g into Π_g due to spin-orbit coupling. Since $^2\Sigma_g$ should not mix with $^2\Pi_{g3/2}$, the transition $^2\Sigma_u^+ \rightarrow ^2\Pi_{g3/2}$ should be very weak, as observed.

The spin-orbit splitting is expected to be small compared to the bandwidth of the infrared absorptions in Cl₂⁻ and F₂⁻; consequently one does not observe the splitting in these two cases. The estimated crystal field perturbations¹ may be of the same order as the spin-orbit interactions; therefore, the absorption $\sigma_u \rightarrow \pi_g$ may be expected to be more complicated. The details of this absorption in Cl₂⁻ are shown in Fig. 5 and may be explained as the superposition of two unresolved transitions $\sigma_u \rightarrow \pi_{g1}$, π_{g2} , both of which are anisotropic.

The simple qualitative explanation involving only

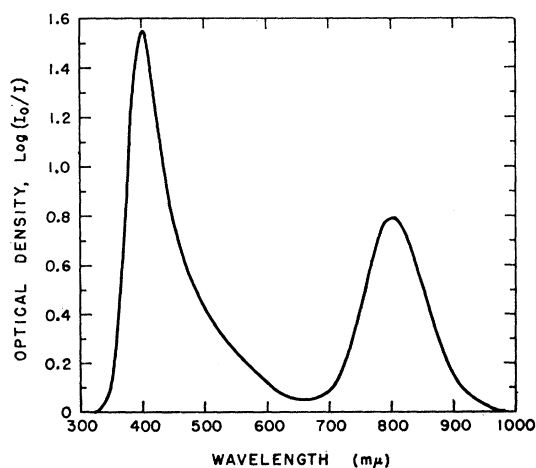

FIG. 8. Anisotropic absorption of the I₂⁻ center in KI.

¹⁶ R. S. Mulliken, J. Chem. Phys. 7, 14, 20 (1939).

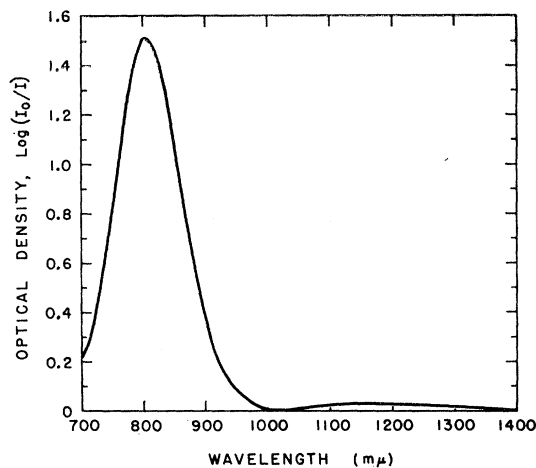

FIG. 9. Absorption spectrum showing the 800- and 1150-m μ I₂⁻ bands in KI.

spin-orbit mixing of the levels does not account for all the details of the spectra. While it does explain the polarization properties and intensities of the ultraviolet bands as well as the 750-m μ band in Br₂⁻ and the 800-m μ band in I₂⁻, it does not explain the polarization properties of the remaining infrared bands. The 585-m μ band in I₂⁻ may be a transition from $^2\Sigma_u$ to $^2\Pi_u$ which is allowed because of a distortion of the I₂⁻ center. This distortion destroys the inversion symmetry of the I₂⁻ center and causes a breakdown of the selection rule forbidding $u \rightarrow u$ transitions. Because of the instability of the I₂⁻ centers, it is not possible to investigate the effects of lattice vibrations on the intensity of this transition between room temperature and liquid nitrogen temperature; however, cooling from liquid nitrogen to liquid helium temperature does not alter the intensity of the transition noticeably.

The enhancement of the population of X₂⁻ centers having a given orientation, which is achieved by bleaching with polarized light into the ultraviolet band at liquid nitrogen temperature, may arise from the fact that the excited state $^2\Sigma_g^+$ contains a net antibonding σ electron and is unstable. In this state the hole may be freed and subsequently retrapped at the same or a different lattice site with any of the possible $\langle 110 \rangle$ orientations. For a σ -polarized transition, if the electric vector of the bleaching light is parallel to the $[0\bar{1}1]$ orientation, the population of the $[011]$ orientation will grow at the expense of the other orientations. Excitation through the red and infrared absorption also changes the population distribution of X₂⁻ centers among the six possible orientations. In this case the $^2\Pi_g$ excited state contains a net bonding π electron and is expected to be only weakly bonding, so that dissociation may also occur. A photoconductivity has been observed due to the motion of holes upon exciting into the 750-m μ band of Br₂⁻ in KBr containing NO₂⁻ ions. In this case, a hole is freed by bleaching into the red

band and moves a short distance through the lattice before being retrapped as Br_2^- .

ACKNOWLEDGMENTS

We wish to thank R. S. Mulliken for suggesting the manner in which spin-orbit interaction might affect the

optical spectra. We wish also to thank M. H. Cohen, T. L. Gilbert, R. S. Knox, and P. G. Lykos for helpful discussions. We are indebted to B. Smaller for the use of paramagnetic resonance equipment, to E. Hutchinson for growing most of the crystals used in the experiments, and to E. Yasaitis and E. C. Avery for experimental support.

Excitons and Plasmons in Superconductors*

A. BARDASIS AND J. R. SCHRIEFFER
University of Illinois, Urbana, Illinois

(Received October 13, 1960)

The Anderson-Rickayzen equations of motion for a superconductor derived within the random-phase approximation (RPA) are used to investigate the collective excitations of superconductors. A spherical harmonic expansion is made of the two-body interaction potential $V(\mathbf{k}, \mathbf{k}')$ and a spectrum of excitations whose energies lie within the energy gap 2Δ is obtained. These excitations may be characterized by the quantum numbers L and M involved in the potential expansion. For an L -state exciton to exist, the L -wave part of the potential must be attractive at the Fermi surface. Odd- L excitons have unit spin and may be considered as spin waves. For s -state pairing in the superconducting ground state, the plasmon mode corresponds to the $L=0$ exciton whose energy is strongly modified by the long-range Coulomb interaction. For a general potential several bound states may exist for given L and M . If the L -wave potential is stronger than the s -wave part of the potential, the system is unstable with respect to formation of L -state excitons. In this case, the ground state is formed with L -state pairing, special cases of which are the p -state pairing considered by Fisher and the d -state pairing proposed recently by several authors for the ground state of He^3 and nuclear matter. Corrections to the Anderson-Rickayzen equations are discussed which lead to a new set of exciton states if the L -wave potential is repulsive. These excitons are interpreted as bound electron-hole pairs, as opposed to the particle-particle excitons present with an attractive L -wave potential.

I. INTRODUCTION

IN the original theory of Bardeen, Cooper, and Schrieffer¹ an approximation to the ground-state wave function of a superconductor was obtained by a variational calculation. Basic to the theory is Cooper's result² that if a net attraction exists between the particles, the Fermi sea is unstable with respect to the formation of bound pairs. The BCS ground-state wave function is formed from a linear combination of normal state-like configurations in which particles are excited to states of low energy above the Fermi surface. In all of these normal configurations, the single-particle states are occupied in pairs ($\mathbf{k}\uparrow, -\mathbf{k}\downarrow$), so that interactions other than those between pairs of electrons of zero net momentum and spin are neglected. The theory leads to the single quasi-particle excitation spectrum given by $E_{\mathbf{k}} = (\epsilon_{\mathbf{k}}^2 + \Delta_{\mathbf{k}}^2)^{1/2}$, where $\epsilon_{\mathbf{k}}$ is the Bloch energy measured with respect to the Fermi level and $\Delta_{\mathbf{k}}$ is the energy gap; that is, $2\Delta_{\mathbf{k}}$ represents the minimum energy required to

excite a pair of quasi-particles from the ground state. The quasi-particle excitations are fermions and no boson excitations appear other than the phonons.

This independent quasi-particle approximation has been surprisingly successful in explaining the thermodynamic properties as well as the acoustic and electromagnetic absorption, the nuclear spin relaxation, and the Meissner effect observed in the superconducting state. The derivation of the last has been criticized because it is not strictly gauge-invariant. This is primarily due to the neglect of residual interactions between particles in states $-\mathbf{k}$ and $\mathbf{k}' \neq \mathbf{k}$. These interactions give rise to a set of collective excitations (bosons) and lead to a gauge-invariant description of the Meissner effect.

For the investigation of these collective excitations, Anderson³ and Bogoliubov, Tolmachev, and Shirkov⁴ have used a generalized time-dependent self-consistent field or random-phase approximation (RPA). Their work shows that in the superconducting state, the plasmon frequency and the plasmon coordinate in the

* This work was supported in part by the Office of Ordnance Research, U. S. Army. One of the authors (A. Bardasis) was aided by a Fellowship from the Minnesota Mining and Manufacturing Company.

¹ J. Bardeen, L. N. Cooper, and J. R. Schrieffer, *Phys. Rev.* **108**, 1175 (1957).

² L. N. Cooper, *Phys. Rev.* **104**, 1189 (1956).

³ P. W. Anderson, *Phys. Rev.* **112**, 1900 (1958).

⁴ N. N. Bogoliubov, V. V. Tolmachev, and D. V. Shirkov, *A New Method in the Theory of Superconductivity* (Consultants Bureau, Inc., New York, 1959).