

Photoproduction of K^+ Mesons in Hydrogen*

H. M. BRODY,† A. M. WETHERELL,‡ AND R. L. WALKER
California Institute of Technology, Pasadena, California

(Received April 29, 1960)

The photoproduction of K^+ mesons in hydrogen has been measured with the purpose of extending the previous CalTech measurements to smaller angles, and obtaining better absolute values for the cross sections. The technique of Donoho and Walker, using a magnetic spectrometer and a time-of-flight measurement to detect the K^+ mesons, was modified so as to achieve a better discrimination against pions and scattered protons. The results obtained are in fairly good agreement with the more extensive measurements made at Cornell by a somewhat different method.

I. INTRODUCTION

THE early work of Donoho and Walker^{1,2} at CalTech, and Silverman, Wilson and Woodward³ at Cornell, showed that K^+ mesons are produced in association with Λ hyperons by photons interacting with hydrogen, whereas the yield of K^+ mesons from the strangeness violating reaction $\gamma + p \rightarrow K^+ + n$ is smaller by at least a factor of 20. Cross sections for the reaction $\gamma + p \rightarrow K^+ + \Lambda$ were measured at several angles and energies by Donoho and Walker, using a magnetic spectrometer in which K^+ particles were identified by their time-of-flight and by the pulse heights produced in three scintillation counters.

More extensive measurements, with better statistical accuracy, have since been made at Cornell^{4,5} using a magnetic spectrometer in which the K^+ particles were identified by stopping them in an aluminum absorber and observing secondary particles from their decay by means of "side" counters surrounding the aluminum block.

The Cornell data,^{4,5} the final cross sections of Donoho and Walker,² and the data from the present experiment are all in reasonably good agreement, although the Cornell numbers are consistently lower than the CalTech ones by roughly 25%. The cross section at photon energies 1010 Mev and below seems to be isotropic in angle, and to have an energy dependence proportional to the K^+ particle momentum in the c.m. system. Both indicate that the photoproduction occurs in an S state at low energies. These statements about the behavior of the cross section with energy and angle are generalizations, and some deviations from them may be seen in the data. In particular the Cornell cross sections at 980 Mev are much lower than the ones at

1010 Mev at the smallest angles investigated. Our values do not show this behavior, although they are statistically less accurate.

The present measurements⁶ were made with the aims of obtaining data at a smaller angle than previously, and improving the accuracy of the absolute values of the cross section. For these purposes the technique of Donoho and Walker was modified as described in Sec. II to permit the taking of data at small angles, and to achieve a more reliable identification of the K particles. In addition, a measurement was made of the cross section for producing K^+ particles in the reaction $\gamma + p \rightarrow K^+ + \Sigma^0$, but the accuracy of this measurement is very poor.

The Cornell measurements,^{4,5} which were carried on at about the same time, are more extensive and serve the same purposes. However, the systematic errors in the two methods are quite different, so that a comparison of the results is useful.

II. EXPERIMENTAL METHOD

The reactions having the lowest thresholds for photoproduction of K^+ mesons from hydrogen are:

$$\gamma + p \rightarrow K^+ + n, \quad (1)$$

$$\gamma + p \rightarrow K^+ + \Lambda, \quad (2)$$

$$\gamma + p \rightarrow K^+ + \Sigma^0. \quad (3)$$

The second and third reactions conserve strangeness, whereas the first does not and has not been observed. These reactions have been investigated by bombarding a hydrogen target with the high-energy x-ray beam from an electron synchrotron, and observing the K^+ particles produced at a given angle and energy. This information determines the incident photon energy in the usual way for a two-body process. Since the photon energy so determined is different for the three reactions, the individual cross sections for all three may be found by measuring the K^+ yield for different synchrotron energies, E_0 . This procedure is described in detail in

* This work was supported in part by the U. S. Atomic Energy Commission.

† Now at the University of Pennsylvania, Philadelphia, Pennsylvania.

‡ Commonwealth Fund Fellow. Now at CERN, Geneva, Switzerland.

¹ P. L. Donoho and R. L. Walker, *Phys. Rev.* **107**, 1198 (1957).

² P. L. Donoho and R. L. Walker, *Phys. Rev.* **112**, 981 (1958).

³ A. Silverman, R. R. Wilson, and W. M. Woodward, *Phys. Rev.* **108**, 501 (1957).

⁴ B. D. McDaniel, A. Silverman, R. R. Wilson, and G. Cortellessa, *Phys. Rev. Letters* **1**, 109 (1958).

⁵ B. D. McDaniel, A. Silverman, R. R. Wilson, and G. Cortellessa, *Phys. Rev.* **115**, 1039 (1959).

⁶ A preliminary report of the present experiment is given in H. M. Brody, A. M. Wetherell, and R. L. Walker, *Phys. Rev.* **110**, 1213 (1958). The cross sections reported in this letter were about 15% too large because of an error in calculation concerning the beam intensity. This was mentioned in reference 2.

references 2 and 5. It has been used both to show that reaction (1) does not occur¹⁻⁵ with the sensitivity of about 5% of reaction (2), and to measure the cross section for reaction (3) at one point.^{4,5} It is also the method used in the present experiment.

K^+ mesons produced in a liquid hydrogen target with a given momentum and angle in the laboratory were detected by using a magnetic spectrometer and associated counters. The apparatus is shown in Fig. 1. The hydrogen target, spectrometer magnet, and three scintillation counters located near the focal point were all the same as used by Donoho and Walker and are described by them.² In order to make small angle measurements possible, the front time-of-flight counter located near the hydrogen target in the previous experiments was replaced by a thin "aperture counter" located at the entrance edge of the magnetic field, where it could also be used to help define the solid angle of acceptance of the spectrometer. The "singles" counting rate of this counter was satisfactorily low at angles as small as 10° in the laboratory, because the fringe field of the magnet provided a sweeping effect, removing low-energy electrons which were the main cause of the singles rate. (The magnetic field reduced this rate by about a factor eight at small angles.)

The change in position of the front counter had two disadvantages, unfortunately. An obvious one was a reduction in the flight path between this counter and the final one, which made the time-of-flight measurement less effective. The second disadvantage was an increase in the background arising from the outer Mylar vacuum jacket of the hydrogen target and from the air path of the x-ray beam. These sources of background had previously been fairly well eliminated by the "collimating" effect of the front counter when located near the target.

Two improvements were made in the technique of discriminating against pions and protons which more than compensated for the decreased effectiveness of the time-of-flight measurement. The first was the addition of a Čerenkov counter, shown in Fig. 1, which was used in veto to eliminate fast particles, mainly pions. The properties of this counter are described in Sec. IIIa. The second improvement was the elimination of most of the protons which scattered from the magnet pole pieces or lead shielding. Protons of the momentum selected by the spectrometer had ranges too small to traverse all the counters, and were not troublesome. However, higher energy protons could scatter from the magnet pole pieces, for example, and pass through the counters with almost the right velocity (and thus specific ionization) to be confused with K particles. Two methods, which are described below in Sec. IIIb were used during the course of this experiment to eliminate these scattered protons.

The characteristics of the bremsstrahlung beam,⁷ the

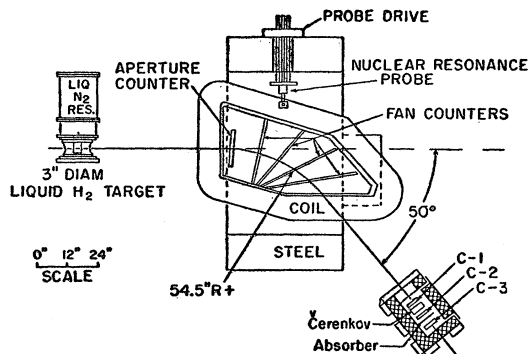

Fig. 1. The magnetic spectrometer and liquid hydrogen target showing the positions of the counters. The "fan counters" are strips of plastic scintillator which spread out over the surfaces of the pole pieces and are used to veto scattered particles.

beam monitor,⁷ and the fast coincidence circuit used for the time-of-flight measurement were as described by Donoho and Walker.² During the measurements at 10° , the beam did not pass clear of the magnet, but buried itself in one coil and pole piece. The beam monitor was then located in front of the magnet coil, and its sensitivity in this position inter-calibrated with that in the normal position.

a. The Čerenkov Counter

The Čerenkov counter was a polished piece of U.V.T. Plexiglas $1\frac{1}{2}$ in. thick and 6×11 in. in area covering the region traversed by the particles. Tapered extensions at the small ends acted as light pipes leading to two RCA type 6810A photomultipliers. A charged particle of $\beta=0.95$ entering this counter normal to the face would produce light at 45° to its direction of motion. Plexiglas of refractive index 1.5 has a critical angle for internal reflection of 41.8° and consequently the light gathering efficiency was quite high.

The counter was wrapped in black paper so that light which did not totally reflect, but escaped the Plexiglas, would be absorbed. This was done in an attempt to reduce the efficiency for particles of $\beta < 0.9$, since they produce light in a more forward direction which hits the large faces of the counter at angles less than 41° . It was hoped that the black paper would also reduce the efficiency of counting slow particles which might have induced the Plexiglas to scintillate weakly.

A series of experimental runs was taken to determine the efficiency of the Čerenkov counter as a function of particle velocity under the conditions of gain and bias used in the experiment. At $\beta=0.95$ it was 98% efficient, while at $\beta=0.7$ and 0.5 only 2% of the charged particles passing through it were detected.

⁷ The absolute calibration of the total beam energy, W was based on a Cornell Quantameter designed by R. R. Wilson, Nuclear Instr. 1, 101 (1957). The number of photons of energy k within dk is $n(k)dk = (W/E_0)B(E_0, k/E_0)dk/k$, where the "bremsstrahlung function," $B(E_0, k/E_0)$, was assumed to be 0.90 for k/E_0 near 0.93 in the present experiment.

b. Elimination of Scattered Particles

The first method used to eliminate scattered protons and other particles was the simple one of making the front aperture counter so narrow that no particle coming from the *hydrogen region* of the target and passing through this counter would hit the pole pieces or lead shielding. This scintillation counter was 32 cm long, 0.64 cm thick, and was tapered from 1.6 cm wide at the top to 5.0 cm wide at the bottom. It defined the aperture completely and gave a solid angle of 0.00408 sr compared to the 0.0078 sr available with the full open aperture.

This narrow aperture counter was designed to eliminate scattered particles originating from the hydrogen in the target. However, it was still geometrically possible for particles produced elsewhere, such as in the outer Mylar vacuum wall of the target, or along the air path of the beam, to pass through the counter and then scatter from the pole pieces into the other counters. Thus, scattered protons still appeared in the data, although they were removed by the subtraction of empty target background, within the statistical accuracy.

In order to reduce the scattered protons in the background and to increase the solid angle of acceptance, the narrow aperture counter was abandoned in favor of a second method of eliminating counts from scattered particles.

The second method was to identify scattered particles by a system of long narrow counters placed against the pole pieces in the manner shown in Fig. 1. These "fan counters" were made from $\frac{3}{4}$ -in. diameter scintillating rods flattened on two opposite sides to a thickness of $\frac{1}{2}$ in., and joined at their bottom ends to curved light pipes. The four counters on each pole face were viewed by a single RCA 6810 photomultiplier, and the pulses from the two photomultipliers were added and placed in 3×10^{-8} sec coincidence with counter C1. The coincidence pulse was then used to veto scattered particles.

The positions and thickness of the fan counters were such that no particle produced in the hydrogen could scatter from the pole pieces and into the final counters without passing through one of the fan counters. Also, particles produced elsewhere and scattering from the pole faces would be similarly detected with high probability.

In addition, the front aperture counter was replaced by one of the same length, but 3 inches wide—sufficient to cover the full horizontal aperture. With this arrangement the vertical aperture was defined by the front counter, whereas the horizontal one was defined by the rear fan counters. The solid angle so determined was 0.00619 sr.

The arrangement of fan counters and wide front aperture counter was quite successful in eliminating scattered particles, as will be discussed in the next section.

III. EXPERIMENTAL DATA AND *K*-PARTICLE IDENTIFICATION

The significant information from all of the counters was recorded on photographic film in the manner of Donoho and Walker,^{1,2} so that correlations between the various bits of information could be used in identifying the *K* particles. An oscilloscope was triggered by each candidate "event" defined as a coincidence (with resolving time about 0.15 μ sec and with low biases) between the output of the fast time-of-flight circuit, and the three final scintillation counters, C1, C2, and C3, with the Čerenkov counter in veto. (The Čerenkov counter was placed in coincidence with counter C1 and the output of this circuit used for the veto.) Several pulses were delayed with respect to each other, mixed, and displayed on the oscilloscope. These were the pulses from C1, C2, C3, the fast time-of-flight circuit output, and, when the fan counters were used, the output of the C1 and fan counter coincidence circuit. The pulses thus displayed for each event were individually photographed on 35-mm film, and were then analyzed as described below.

Before and after each *K*-meson run, a pion calibration run was taken by setting the time-of-flight circuit to the proper delay and placing the Čerenkov circuit in coincidence. Approximately 100 pion pictures were taken on each calibration run and in this way the time of flight circuit and the three scintillation counters were kept under surveillance as to efficiency and shifts in gain.

The photographed scope traces were viewed on a 35-mm slide projector and the height of every pulse was recorded. The pion runs were analyzed by plotting histograms of the pulse height in each of the three scintillation counters. From the known energy loss for *K* and π mesons at a given momentum, and because of the linearity of the electronics, it was then possible to predict the limits of the expected *K*-meson pulse heights in these counters.

The pulse-height spectra from the time-of-flight circuit were also examined for the pion runs and a minimum pulse-height limit determined such that 85% of the pions gave pulses larger than this limit. The way in which this "time-of-flight efficiency" was determined is described in Sec. IIIb. In the second series of runs (in which the fan counters were used) there was a small steady drift from day to day in the output of the time-of-flight circuit. Since each run was individually calibrated, this drift was quite apparent and easily compensated for.

The *K* runs were analyzed in the following manner. All events containing a time-of-flight pulse below the minimum value set by the calibration runs, or a fan counter veto pulse, were discarded. The remaining events were analyzed by making a "dot plot" of the pulse heights on log-log paper, as shown for one run in Fig. 2, for example. On a "dot plot" every event was represented by a dot, the coordinates of which were

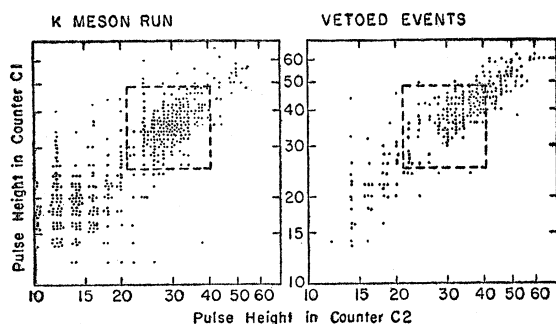

FIG. 2. "Dot plots" for Data Group 3B of Table I. Pulse heights from counters C1 and C2 are plotted for all events regardless of the pulse in C3. The left hand plot contains events with no fan counter pulse and shows the K -particle group in the boxed region and also a pion group. (For some of the other runs the Čerenkov counter was more efficient than in this run, and many fewer pions appeared in the dot plots.) The right-hand plot contains events accompanied by a fan counter pulse. Many of these events are protons scattered from the pole pieces, as expected. These events were not used as data, of course, and they were analyzed only to investigate the usefulness of the fan counters.

the values of the pulse heights in C-1 (first counter) and C-2 (second counter).

The limits of the predicted pulse heights for K mesons in these two counters were indicated by dashed lines on the dot plots. Within these predicted limits there was a good grouping of points which were tentatively identified as K mesons. Only rarely did an event falling within these limits have a pulse height in C-3 outside of the limits predicted for K particles. Only a small fraction of the events that were outside of the limits for C-1 or C-2 fell within the C-3 limits. Some of the events that were minimum ionizing in C-1 and C-2, but larger in C-3 could be explained by the interaction of pions or electrons in a $\frac{1}{2}$ -in. piece of lead placed between C-2 and C-3. Events having pulse heights within the proper limits in all three counters were counted as K mesons.

Although the correlated pulse heights in all three scintillation counters were used to identify K particles, the Čerenkov counter, the antiscattering fan counters, and the time-of-flight requirements were sufficiently effective in eliminating pions and scattered protons, that the pulse height in one scintillation counter alone provided almost enough additional information to make the identification. This fact, which gives confidence in the K -particle identification, is illustrated in Fig. 3, where the pulse-height spectra for a single counter are plotted, for two K runs and a pion calibration run.

a. Scattered Particles

In order to investigate the number of scattered particles and the pulse heights they produce in the scintillators, the fan counter pulse (C1+fan counter coincidence) was displayed on the oscilloscope rather than used to veto events electronically. The events producing a fan counter pulse could then be analyzed separately from the others.

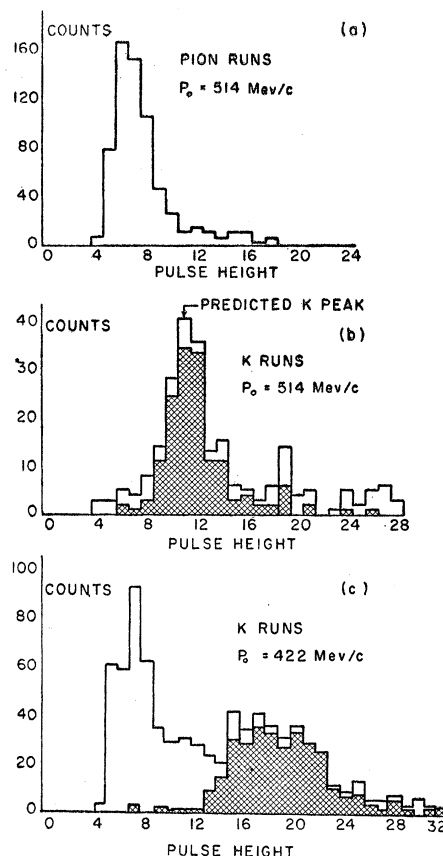

FIG. 3. Single counter pulse-height spectra for counter C3. The upper histogram, *a*, shows the spectrum observed for the pion calibration runs associated with data group 1A of Table I. The central histogram, *b*, shows the pulse-height spectrum for the K runs of data group 1A. The cross hatched histogram includes all events which would be identified as K^+ mesons on the basis of the pulses in counters C1 and C2, whereas all other events are added in the clear regions. Note that very few pions appear, because the Čerenkov counter was very efficient during this run. The lower histogram, *c*, is the same as *b* except that it refers to the K runs of data group 3B. The Čerenkov counter was less efficient for these runs (which gave the dot plot in Fig. 2) and a pion peak appears in the pulse-height spectrum, as well as the K -particle peak. The events having pulses in the K regions in counters C1 and C2 (indicated by cross hatching) show only the K peak in C3.

In the pion calibration runs, about 20% of the events had a fan counter pulse. This was approximately the amount by which the solid angle was reduced by the fan counters, and thus most of these events were presumably pions which passed through these counters without scattering.

For the K runs, however, about 40% of the events contained a fan counter pulse. A little less than half of these were presumably unscattered particles, as in the pion runs, but the rest must have been scattered particles. The large number of such events in the K runs resulted from the fact that the selection criteria discriminated strongly against unscattered pions and protons, whereas they did not discriminate strongly against some of the scattered protons, for example.

“Dot plots” of the events containing fan counter pulses indicated that many of these counts were scattered protons as expected. An example is shown in Fig. 2.

b. Efficiency of the Time-of-Flight Circuit

At the momentum used in obtaining most of the data, 425 Mev/c, the difference in transit times for π and K mesons had an average value of 4 μ sec, with some spread about this average. Since the coincidence resolving time was comparable to this, a complete separation of π and K mesons was not possible and a compromise was made to reject most of the pions without losing too many K particles.

This was done by choosing the lower pulse-height limit accepted for the time-of-flight circuit output at the value for which this circuit would be 85% efficient in counting K mesons. With this limit, the pion rejection factor was about 10 to 1, which, combined with the 50 to 1 pion rejection of the Čerenkov counter, was satisfactory.

The efficiency of the time-of-flight circuit in counting K mesons enters directly in the cross section, so it is important to determine it correctly. This efficiency was measured for pions or protons (with the delay set for the appropriate particle) and it was assumed that the efficiency for K particles (with the proper delay) would be the same. In support of this was the fact that the time-of-flight output pulse-height spectra were the same for the three kinds of particles. Also Donoho and Walker² found that the efficiency for pions and protons was the same.

During the first set of runs, in which the narrow aperture counter was used, the efficiency was measured for protons by constructing a lead slit slightly smaller than the counter so that all protons detected would have to pass through the counter. Counting rates with and without the time-of-flight coincidence requirement were measured simultaneously, and differed by only one percent. Thus 99% of the protons led to photographed events, and the pulse-height limit for which the time of flight circuit was 85% efficient was easily determined.

During the second set of runs, in which the fan counters and wide aperture counter were used, the efficiency was measured for pions by installing a second and smaller aperture counter immediately in front of the normal one so that no pion could count in the smaller counter without also passing through the normal one. Again the counting rates with and without the time-of-flight coincidence requirement were measured simultaneously to obtain the fraction of pions which would lead to photographed events, and from this fraction the pulse height giving 85% efficiency was determined. During this second set of runs the time-of-flight output spectra showed a steady drift from day to day, so that measurements of the efficiency were made several times. The fraction of pions giving photographed events decreased from 99% to 90% during the course of the

experiment and the pulse-height limit giving 85% efficiency changed correspondingly.

IV. BACKGROUNDS

Background counting rates without hydrogen in the target were subtracted from the full target counting rates to obtain the yield from hydrogen. This is appropriate if one has confidence in the K -meson identification so that pions and protons make little contribution to the K counting rate, and if there may be appreciable sources of background K particles such as the vacuum walls of the target and the air path of the beam.

In the experiment of Donoho and Walker,^{1,2} background from these sources was reduced by the collimating effect of the front counter located near the target, but there was more chance of counting pions or protons as K particles. Thus it seemed more appropriate to subtract as “background” the counting rates observed from the full hydrogen target with the synchrotron energy E_0 lowered just below the value required to produce K particles of the momentum and angle selected by the magnet. Two such runs with E_0 “below threshold” were taken in the present experiment, and indeed gave counting rates smaller than the empty target background with normal E_0 .

Data for the empty target backgrounds and also the runs below threshold are shown together with the full target data in Table I. It may be seen that the background counting rates are quite large—being about 15% at 25° and 30% at 10° in the laboratory system. The amount of material in the beam (target walls and air) which is seen by the spectrometer increases as the angle decreases, and this accounts for the greater background at 10° than at 25°. The number of K mesons observed in the empty target runs was actually somewhat larger than might be expected from the number of protons in this material compared to the number in the liquid hydrogen. This might be accounted for by K particles produced in the reactions $\gamma + p \rightarrow K^+ + \Sigma^0$ and $\gamma + n \rightarrow K^+ + \Sigma^-$, which are eliminated kinematically from hydrogen, but not for heavier nuclei because of the motion of the nucleons in these nuclei. This nucleon motion contributing to the $K + \Lambda$ reaction might also account for the small counting rate observed at 10° with the bremsstrahlung energy “below threshold.”

V. RESULTS AND REMARKS

The counting rates observed under various experimental conditions are given in Table I. Also shown in this table are the cross sections obtained after making several corrections. (Note that the last cross section shown is for the reaction $\gamma + p \rightarrow K^+ + \Sigma^0$, and is very inaccurate. It was obtained by subtracting Data Groups 4B and 5B, following the procedure indicated in Sec. II.)

The major correction made was for decay of the K mesons in flight. The fraction of K particles which

TABLE I. Experimental data and results. The designations A and B with the data group number (column 1) refer to the two different arrangements used to eliminate scattered protons. A refers to the arrangement with narrow aperture counter, and B to that with the "fan counters." P_0 and E_0 are the spectrometer momentum setting and the bremsstrahlung end point energy, respectively. The target designation H_2 refers to results of subtracting empty target from full target data. k is the photon energy in the laboratory system, and $\theta_{c.m.}$ the K -particle angle in the c.m. system. Counting rates are given in counts per 10^{11} equivalent quanta (E.Q.). The last column is the cross section "normalized" to 1000 Mev assuming that $\sigma(\theta)$ is proportional to the K momentum, $p(k)$, in the c.m. system.

Data group	P_0 Mev	θ_{lab}	E_0 Mev	Target	k Mev	$\theta_{c.m.}$	No. of K^+	Counting rate per 10^{11} E.Q.	$\sigma(\theta)$ 10^{-31} cm ² /sr	$\frac{p(1000)\sigma(\theta)}{p(k)}$ 10^{-31} cm ² /sr
$\gamma+p \rightarrow K^++\Lambda$										
1A	514	10°	1072	Full	1000	28.5°	136	1.39±0.119	1.60±0.23	1.60±0.23
			Empty				25	0.43±0.086		
			H_2					0.96±0.145		
			900	Full				0.18±0.07		
2A	420	25°	1072	Full	1000	72°	128	0.589±0.52	1.56±0.175	1.56±0.175
			Empty				8	0.071±0.025		
			H_2					0.518±0.057		
			900	Full			0	0.00±0.02		
3B	422	25°	1080	Full	1000	72°	386	0.99±0.05	1.51±0.12	1.51±0.12
			Empty				23	0.20±0.04		
			H_2					0.79±0.065		
4B	422	10°	1025	Full	953	35°	115	1.15±0.11	1.15±0.20	1.70±0.30
			Empty				9	0.34±0.11		
			H_2					0.81±0.16		
5B	422	10°	1115	Full			180	1.57±0.12		
			Empty				20	0.55±0.12		
			H_2					1.02±0.17		
$\gamma+p \rightarrow K^++\Sigma^0$ (From subtraction of data group 4B from group 5B)										
			H_2		1073	40°		0.21±0.22	0.34±0.34	

reached the last counter before decaying was 0.275 for momentum $P_0=422$ Mev and 0.347 for $P_0=514$ Mev, assuming a mean life 1.22×10^{-8} sec. An estimate was made of the number of K -meson decay products which would be detected and identified as K particles, and this gave a correction of less than two percent.

Other corrections were made for the time-of-flight efficiency, the fraction of K 's vetoed by the Čerenkov counter, scattering, and nuclear absorption of the K particles in the counters and $\frac{1}{2}$ -in. lead absorber.⁸

The cross sections obtained at 1000 Mev are plotted in Fig. 4 together with the results of Donoho and Walker^{1,2} at the same energy, and the Cornell cross sections of McDaniel *et al.*^{4,5} at 1010 Mev. (Note that the Cornell values at 980 Mev, which are not shown, are significantly lower.) The angular distribution at 1000 Mev is isotropic within the experimental errors, and this is one piece of evidence for believing that the $K^++\Lambda$ production is mainly in an S state at energies not far above the threshold, 910 Mev. The other evidence is the fact mentioned in the introduction that as a function of energy the cross section is approximately proportional to the K -particle momentum in the c.m. system.

Our data are described very well by these simple generalizations; namely that the cross section is independent of angle and proportional to the K -particle

⁸ The nuclear absorption was estimated from the cross sections measured by L. T. Kerth, T. F. Kycia, and L. Van Rossum, Phys. Rev. **109**, 1784 (1958).

momentum in the c.m. system. This is shown by the last column of Table I, which gives the cross section divided by this momentum, and multiplied by the momentum at $k=1000$ Mev for normalization. This "normalized" cross section, $[\frac{p(1000)}{p(k)}]\sigma(\theta)$, is about 1.55×10^{-31} cm²/sr for every point, well within the errors.

The data of McDaniel *et al.*^{4,5} show some deviations from the above simple behavior of the cross section, al-

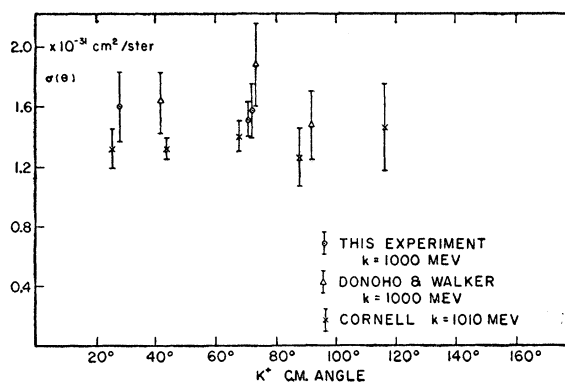

Fig. 4. The angular distribution of K mesons produced in the reaction $\gamma+p \rightarrow K^++\Lambda$ at photon energies 1000 and 1010 Mev. Values of the differential cross section obtained in the present experiment are compared to those of McDaniel *et al.* (references 4 and 5) at Cornell, and those of Donoho and Walker (references 1 and 2).

though most of their data are described fairly well by this behavior. The most notable deviation is the forward angle point (28° c.m.) at 980 Mev, for which the value of $[\rho(1000)/\rho(k)]\sigma(\theta)$ is $(0.84 \pm 0.11) \times 10^{-31}$ cm²/sr compared to an average value of 1.25 or 1.3×10^{-31} cm²/sr for their data at 1010 Mev, and 1.02 to 1.15×10^{-31} cm²/sr for the other angles at 980 Mev. This rapid decrease in the forward angle cross section toward low photon energies was not observed in our experiment.

The difference of roughly 25% between the Cornell average for $[\rho(1000)/\rho(k)]\sigma(\theta)$ and ours is presumably a measure of the difference in the systematic errors of the two experiments.

A comparison of the experimental data with the

available theories was discussed by McDaniel *et al.*^{4,5} and we refer their article for this discussion.

VI. ACKNOWLEDGMENTS

We would like to thank R. Diebold for help in analyzing the data, E. Emery for maintenance of the hydrogen target, J. Boyden for aid in constructing the fan counters, and A. Neubeiser and other members of the laboratory for assistance in the operation of the synchrotron. One of us, A.M.W., would like to thank Professor R. F. Bacher and the members of the Synchrotron Laboratory for their kind hospitality during his stay in CalTech. He is also grateful to the Commonwealth Fund of New York for a grant.

Experiment on Charge Independence in Interactions of Nucleons and Pions

D. HARTING, J. C. KLUYVER, A. KUSUMEGI,* R. RIGOPOULOS,† A. M. SACHS,‡
G. TIBELL, G. VANDERHAEGHE, AND G. WEBER
CERN, Geneva, Switzerland

(Received April 18, 1960)

The ratio (R) of the differential cross sections of the reactions $p+d \rightarrow H^3+\pi^+$ and $p+d \rightarrow He^3+\pi^0$ has been measured at a bombarding energy $E_p=591$ Mev. The He^3 and H^3 nuclei are detected by the combination of magnetic deflection, time-of-flight measurement and pulse-height selection. The results are $R=2.26 \pm 0.11$, 2.10 ± 0.14 , and 2.05 ± 0.09 at c.m. angles of the heavy particles of 52° , 67° , and 143° , respectively. The agreement with the predictions of charge independence is satisfactory when the Coulomb and mass corrections are taken into account.

1. INTRODUCTION

SINCE the hypothesis of charge independence of nuclear forces was first formulated, this principle has, by its simplicity and general usefulness, contributed decisively to the understanding of a great variety of phenomena in nuclear physics. The fundamental nature of this principle and the associated concept of isotopic spin was strongly confirmed by the success of its application to pion-nucleon interactions.

The principle distinguishes between pure nuclear interactions which are assumed to be charge independent and other interactions, dependent on the charge of the elementary particles, that are responsible for Coulomb forces and mass effects. Every conclusion derived from charge-independent theory has therefore to be amended for the effect of these charge-dependent interactions, before a comparison with experimental data can be made. Whereas it is often possible to make predictions on the basis of charge independence, which are independent of the model assumed in the theoretical treatment of nuclear structure, such a specific model is in general required for the calculation of the Coulomb

corrections. The most critical tests are thus provided by those experiments for which the Coulomb corrections can be calculated and be shown to be small. The number of pertinent experiments in pion physics which can be performed with high accuracy is rather limited. Many of the proposed experimental tests involve the detection of neutral particles for which the techniques are not yet sufficiently developed to reach high experimental precision. It was recognized early that this difficulty can be avoided in the experiment which is the subject of the present paper. According to charge independence the angular distribution of the reactions:

$$p+d \rightarrow H^3+\pi^+, \quad (1)$$

and

$$p+d \rightarrow He^3+\pi^0 \quad (2)$$

are the same and the ratio of the absolute cross sections (R) is 2.¹ As the cross sections of these reactions may be obtained by detecting only the H^3 and He^3 nuclei, which are produced by the same proton beam for both reactions, no neutral particles are involved in the measurement. Experimentally the main problem is the small cross section of these processes compared to those

* Now at University of Kyoto, Kyoto, Japan.

† Now at University of Birmingham, Birmingham, England.

‡ National Science Foundation Senior Postdoctoral Fellow on leave from Columbia University 1958-1959, New York, New York.

¹ A. M. L. Messiah, Phys. Rev. 86, 430 (1952); M. Ruderman, Phys. Rev. 87, 383 (1952).