

Boron Plus Deuteron Reactions*†

R. W. KAVANAGH AND C. A. BARNES

Kellogg Radiation Laboratory, California Institute of Technology, Pasadena, California

(Received June 16, 1958)

Gamma and alpha emission from the 15-Mev level of C^{12} is investigated in the reaction $B^{11}(d,n)C^{12*}$. An upper limit on the ratio of α - to γ -radiation from the state is $\Gamma_\alpha/\Gamma_\gamma < 1.5$. The excitation threshold for 15-Mev gamma radiation is 1.633 ± 0.003 Mev, and the cross section is given as a function of bombarding energy up to 3.25 Mev. Resonances are found at 2.180 ± 0.010 and 3.080 ± 0.015 Mev. Momentum analyses of α particles from deuteron bombardment of B^{10} and natural boron reveal no excited states in Be^8 in the range of excitation 9.8 to 14.8 Mev, and no new states in Be^9 below 4.7-Mev excitation. The nature of the 1.75-Mev level of Be^9 is discussed. The branching of the β -decay of B^{12} to the 4.43-Mev state of C^{12} is found to be $1.4 \pm 0.4\%$, allowing the unique assignment $J=1^+$ to the B^{12} ground state, which is presumed to be the analog of the 15-Mev state of C^{12} . Upper limits of (0.00 ± 0.01) and $(0.1 \pm 0.1)\%$, respectively, are found for γ rays with $E_\gamma > 6$ Mev and $E_\gamma = 3.2$ Mev following B^{12} decay. The cross section for the production of B^{12} is given as a function of bombarding energy for $0.5 \leq E_d \leq 3.25$ Mev.

I. INTRODUCTION

INVESTIGATORS at several laboratories have reported observation of a 15-Mev gamma ray, presumed to originate from the known level at that energy in C^{12} (see Fig. 1).¹ The earliest report was that of Cohen, Moyer, Shaw, and Waddell,² who observed a gamma ray with 15.2 ± 0.2 Mev energy, using a 180° pair spectrometer, during bombardment of carbon with protons of 30- to 340-Mev energy, and also during bombardment of thick B^{11} targets with deuterons of 18-, 30-, and 50-Mev energy. It was also sought, but not observed, from proton bombardment of Be , B^{10} , and O^{16} , and from alpha bombardment of beryllium. These facts were taken to indicate that the gamma ray originated from the 15.1-Mev level in C^{12} already found³ from a neutron group from $B^{11}(d,n)C^{12}$. This level is unstable to alpha-emission to states in Be^8 up to 7.7 Mev, and the presence of the gamma radiation led to the suggestion that the state is the B^{12} ground-state analog with $T=1$, which should lie at about that energy. To the extent that there occurs no mixing with states having zero isotopic spin, breakup into $Be^8 + \alpha$ (or into 3α) in low-lying states is then forbidden, and the radiation thus accounted for. However, some such mixing does occur, presumably in the compound state, in the reaction $N^{14}(d,\alpha)C^{12}$, which has been observed by the Indiana group to give a thick $N_6C_3H_6$ -target yield of 15-Mev gamma radiation of about 3% of the thick B_4C -target yield ($\sim 3 \times 10^{-5} \gamma/d$) from $B^{11}(d,n)C^{12}$ at the same bombarding energy (10.8 Mev).⁴ The Indiana

group also found a small yield ($\sim 6\%$ of the $B+d$ yield) of $Be^9(\alpha, n\gamma_{15})C^{12}$ using 21.7-Mev alphas. Some inhibition of formation of the 15.1-Mev state might be expected here, if Be^9 be regarded as made up of two alphas and a neutron loosely bound, since merely replacing the neutron with the incoming alpha could not form a $T=1$ state. Recent work by Waddell⁵ has shown the 15-Mev radiation to be present in the reactions $C^{12}(p,p')C^{12*}$, $C^{12}(n,n')C^{12*}$, $B^{11}(d,n)C^{12*}$ and $Be^9(\alpha,n)C^{12*}$ but absent in $C^{12}(\alpha,\alpha')C^{12*}$ and $C^{12}(d,d')C^{12*}$ except at energies high enough that breakup of the outgoing alpha or deuteron would be expected. A 10.7-Mev gamma ray has also been found by Waddell⁵ in $C^{12}(p,p')$, with 9.5% of the intensity of the 15.1-Mev radiation, indicating that cascading through the C^{12} 4.43-Mev state is present.

The present work was undertaken to investigate the width and branching between alpha particles and gamma rays of the 15.1-Mev state. Since it appeared likely that this state is in fact the analog of the B^{12} ground state, the spin and parity of the B^{12} ground state was investigated by studying the branching of the β -decay of B^{12} .

Subsequently Fuller, Hayward, and Svantesson⁶ have found a photon scattering maximum from C^{12} irradiated with bremsstrahlung from the National Bureau of Standards betatron, corresponding to a level at 15.0 ± 0.2 Mev. From the difference in the scattered intensity with graphite absorber placed before and after the scatterer, they determined the level width to be less than 10 kev (the energy of the C^{12} recoil). More recent work by Hayward and Fuller⁷ has shown the level width to be $\Gamma = 79 \pm 16$ volts, with $\Gamma_\gamma/\Gamma = 0.69 \pm 0.07$.

The 15.1-Mev gamma ray has also been studied

* Supported in part by the joint program of the Office of Naval Research and the U. S. Atomic Energy Commission.

† A preliminary report of this work was given at the Winter Meeting of the American Physical Society at Los Angeles, Phys. Rev. **100**, 1796(A) (1955).

¹ F. Ajzenberg and T. Lauritsen, Revs. Modern Phys. **27**, 77 (1955).

² Cohen, Moyer, Shaw, and Waddell, Phys. Rev. **96**, 714 (1954).

³ V. R. Johnson, Phys. Rev. **86**, 302 (1952).

⁴ Rasmussen, Rees, Sampson, and Wall, Phys. Rev. **96**, 812 (1954).

⁵ C. N. Waddell, Ph.D. thesis, University of California, 1957 (unpublished).

⁶ Fuller, Hayward, and Svantesson, Bull. Am. Phys. Soc. Ser. II, **1**, 21 (1956).

⁷ E. Hayward and E. G. Fuller, Phys. Rev. **106**, 991 (1957).

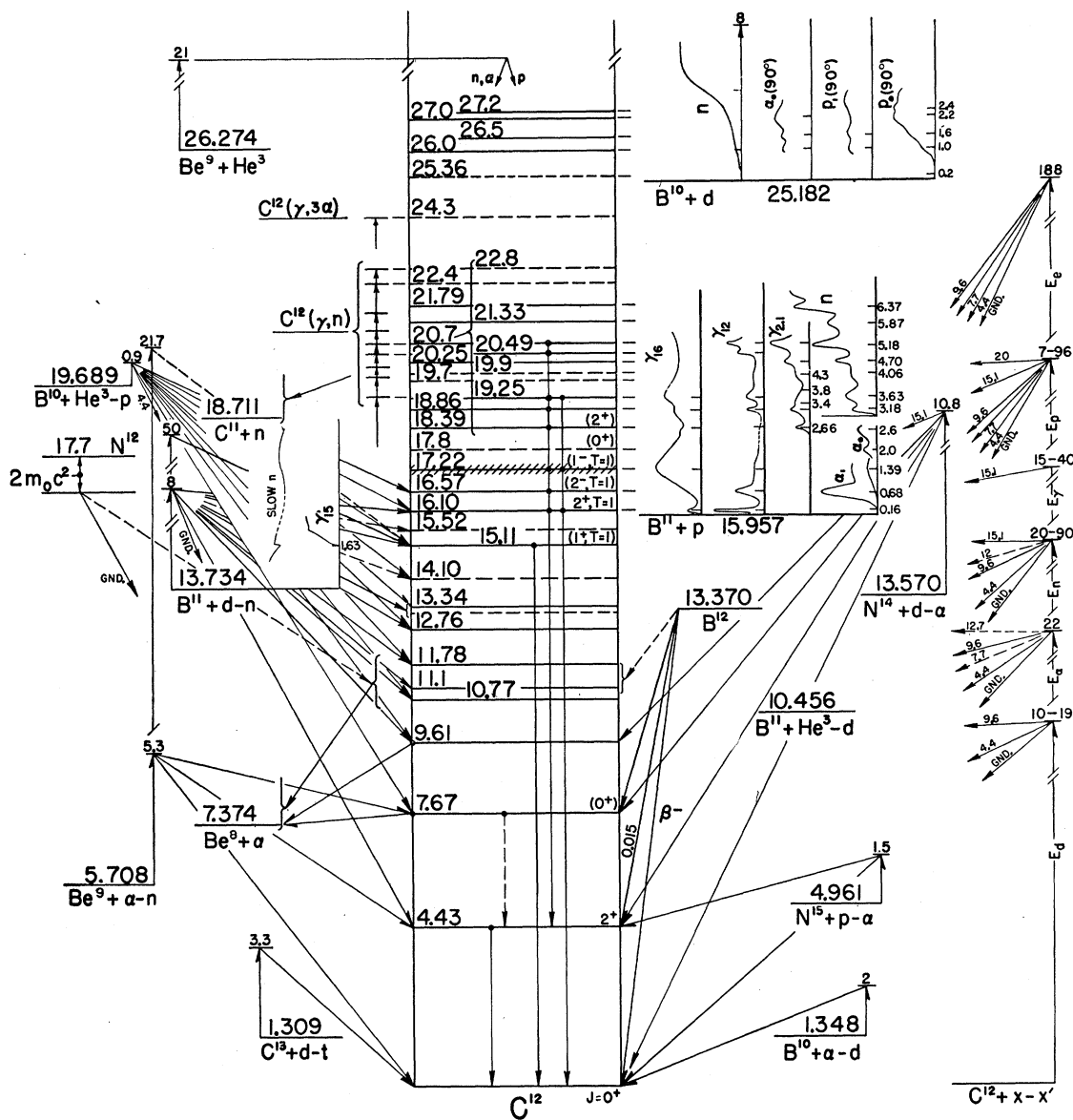

FIG. 1. Energy level diagram of C^{12} , after Ajzenberg and Lauritsen (reference 1) with some additions.

recently through the $B^{10}(He^3, p)$ and $C^{13}(He^3, \alpha)$ reactions.⁸

II. METHODS

Deuterons having energies up to 3.25 Mev were used to bombard various boron targets after electrostatic analysis to one- or two-tenths percent in energy. The high-energy gamma rays were detected with a 4-in. \times 4-in. NaI crystal spectrometer. Due to the high yield of lower energy gamma rays and neutrons, it was found necessary to reduce the counting rates considerably below target and machine capacity to avoid pile-up and gain-drift in the photomultiplier. The crystal was

⁸ E. Almqvist (private communication), and Bull. Am. Phys. Soc. Ser. II, 2, 51 (1957).

shielded around the sides with three inches of lead and, as neutron shielding, with B_2O_3 -loaded paraffin, about three inches of paraffin around the sides and about four inches in front being typical.

Charged particles were analyzed with the aid of a 16-inch double-focusing magnetic spectrometer, usually using the maximum available solid angle of 0.0063 steradian and a momentum resolution of 230. Calibrations were made with Th-C alpha-particle groups and with reactions having well-known Q values such as $C^{12}(d, p)C^{13}$. Since the principal interest was in alpha-particle yields, a thin crystal of CsI just thick enough to stop alpha particles of about 5 Mev was made by milling a CsI wafer glued to a glass slide. The resulting

scintillator, mounted on a DuMont 6292 photomultiplier tube, gave nine percent resolution for 4-Mev alphas. For deuterons the maximum pulse height was achieved at 1.6 Mev, indicating a thickness of 0.001 inch. This is also the range of 1.4-Mev protons and thus integral biasing of scalers was sufficient to discriminate in favor of alphas over 3 Mev. (Magnetic analysis passes protons and alphas having the same energy, and in a thick CsI crystal the proton pulses are somewhat greater than the alpha pulses.)

Thin boron targets were made by evaporation of natural boron (81% B^{11} , 19% B^{10}) from tungsten wire onto 0.003-inch tantalum backing, a typical target being 5.3 kev thick to 800-kev deuterons. However, some of the thickness was due to oxygen and carbon contaminations which, after many hours of bombardment, were estimated to be 2.3 kev and 1 kev, respectively. These thicknesses were evaluated by comparing the $O^{16}(d,p)O^{17}$ and $C^{12}(d,p)C^{13}$ yields in the 16-inch magnetic spectrometer with published cross sections⁹ (interpolated in the latter case). The need for an accurate target thickness determination was avoided by directly measuring the cross section of the reaction $B^{11}(d,\alpha)Be^9$ from the thick-target yield curve, using a pure B^{11} target¹⁰ obtained from Harwell. If N_q is the spectrometer counting rate at the top of the thick-target step per q microcoulombs of bombarding particles, the cross section is given by

$$\sigma = \frac{N_q R}{q \Omega_c E_2} \left| \epsilon_1 \frac{\partial E_2}{\partial E_1} + \epsilon_2 \frac{\cos \theta_1}{\cos \theta_2} \right| \text{ millibarns,}^{11}$$

where R is the spectrometer momentum resolution, Ω_c is the solid angle (in center-of-mass system) of the spectrometer, E_1 is the bombarding energy in electron volts, E_2 is the energy of outgoing particles in electron volts, θ_1 , θ_2 are the incident and outgoing angles, measured from the normal to the target on the bombarded side, and ϵ_1 , ϵ_2 are the stopping cross sections in 10^{-15} ev-cm² for the incident and outgoing particles, obtained by interpolation from the curves of Whaling.¹² Then from the integrated yield from a thin target, $\int N_q(I) (dI/I)$, under the same bombarding and detection conditions, the surface density, nt , of the boron nuclei (parallel to the incident beam) is

$$10^{-15} nt = \frac{2R}{q \Omega_c \sigma} \int \frac{N_q(I)}{I} dI \text{ cm}^{-2},$$

⁹ Stratton, Blair, Famularo, and Stuart, *Phys. Rev.* **98**, 629 (1955); Bonner, Eisinger, Kraus, and Marion, *Phys. Rev.* **101**, 209 (1956); G. C. Phillips, *Phys. Rev.* **80**, 164 (1950).

¹⁰ We are indebted to Dr. M. L. Smith of the Atomic Energy Research Establishment, Harwell, England for supplying the separated boron targets.

¹¹ Snyder, Rubin, Fowler, and Lauritsen, *Rev. Sci. Instr.* **21**, 852 (1950).

¹² W. Whaling, *Handbuch der Physik* (Springer-Verlag, Berlin, 1958), Vol. 34, p. 193.

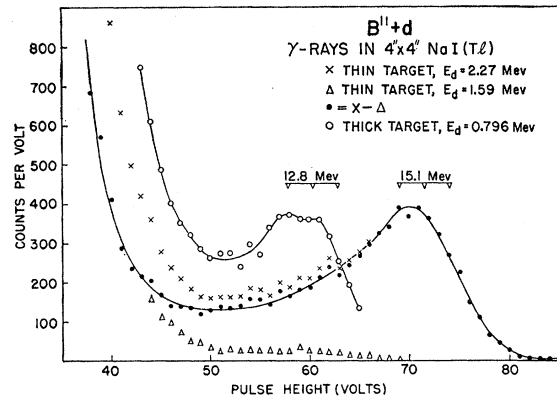

FIG. 2. Pulse-height spectrum of high-energy gamma rays from $B^{11}+d$.

where σ is the value determined from the thick target yield and I is the fluxmeter reading, which is inversely proportional to the magnetic rigidity. Direct measurement of the thickness of a thin B^{11} target by measuring the shift of the elastic scattering edge was not considered reliable because the boron was embedded in the tantalum backing by the isotope separator. A check of the elastic scattering profile from the copper backing of the thick target, however, revealed only a negligible mixing of the copper with the boron in the first few hundred micrograms per cm². It is presumed that with increasing boron deposition the copper atoms in the surface region become increasingly dilute.

By comparison of the thick-target step with the thin-target integrated yield as outlined, the thin target was found to have a surface density of B^{11} of 36 $\mu\text{g}/\text{cm}^2$. Interpolated values for ϵ_1 and ϵ_2 used for boron were, respectively, 4.45 for 1.70-Mev deuterons and 10.3 for 7.2-Mev alpha particles.

III. RESULTS

The high-energy gamma-ray spectrum resulting from the deuteron bombardment of the 36- $\mu\text{g}/\text{cm}^2$ B^{11} target is shown in Fig. 2 for two bombarding energies, above and below the expected threshold to the 15-Mev state of C^{12} . The difference between the yields is plotted as solid circles and taken to be the net yield of 15-Mev radiation from 50 to 80 volts pulse height. The lowest point of the curve was extrapolated to zero pulse height as a constant Compton plateau, the total area thus formed giving the total yield used to determine the cross section for the reaction. The counter efficiency was found by numerical integration, using published NaI cross sections,¹³ and a 15% correction applied for the interposed absorbers.

The $B^{11}(d,n\gamma_{15})C^{12}$ cross section at 2.2 Mev was thus found to be 29 ± 7 millibarns. The anisotropy was less than four percent at 2.5 Mev, with $I(90^\circ)/I(0^\circ)$ in-

¹³ G. R. White, National Bureau of Standards Report NBS-1003, May, 1952 (unpublished).

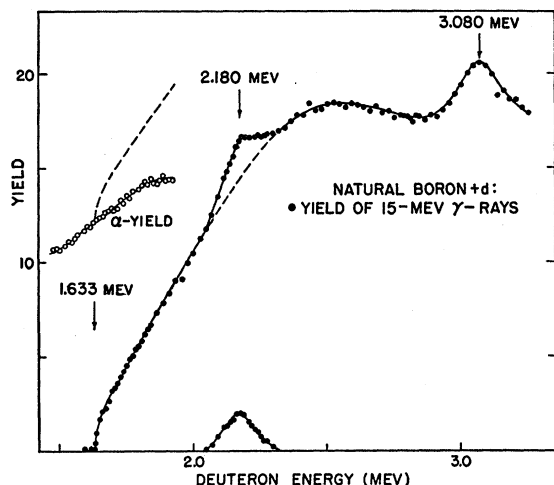

FIG. 3. Thin target excitation curves for 15-Mev gamma radiation (solid circles) and for alpha particles (open circles) of selected momentum (see text). The peaking of the gamma yield at 2.180 Mev has been emphasized by plotting the difference between the actual curve and the smoothed (dashed) curve.

creasing slowly with decreasing energy to a value of 1.15 ± 0.04 at 1.7 Mev (just above threshold).

The high-energy tail shown in Fig. 2 for 1.59-Mev deuteron energy decreased smoothly in intensity with decreasing bombarding energy, at 550 kev the yield above 50 volts pulse height being about one-tenth that at 1.6 Mev. Also shown is the gamma-ray spectrum at 796-kev bombarding energy obtained with a $600\text{-}\mu\text{g}/\text{cm}^2$ Harwell B^{11} target. The peak in the spectrum is appropriate to a gamma ray of 12.8 ± 0.3 Mev, calibrated in terms of the 15.1-Mev peak in the figure. The yield per microcoulomb was independent of the beam intensity, hence random coincidence of lower energy pulses was not involved here. The possibility of real coincidences between the 4.43-Mev gamma ray and its accompanying fast neutron was ruled out on the basis of known or limiting values of cross sections, the geometry involved, and the resolving time of one microsecond (which limits the neutron diffusion time). That molecular hydrogen contamination of the mass two beam was not

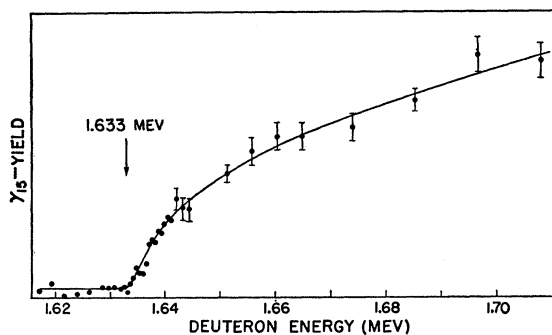

FIG. 4. 15-Mev gamma ray yield vs bombarding energy near threshold. The curve is calculated for a 3-kev target thickness and a cross section varying as $(E-1.633)^{1/2}$ Mev.

the source, through the known 12-Mev gamma ray from $B^{11}(p,\gamma)C^{12}$, was checked by verifying that the yield was nonresonant and small over the deuteron energy range 300 to 356 kev, spanning the known proton resonance at 163 kev. It is therefore concluded that it is a gamma ray originating from a state in C^{12} at 12.8 Mev, perhaps the known state at 12.76 Mev.¹ The cross section for its production at 1.6 Mev is estimated to be about 4% of that for the 15.1-Mev gamma ray at 2.2 Mev, or about 1.2 millibarns. Waddell⁵ has also observed 12.8-Mev gamma radiation from $C^{12}(p,p')$, with 9% of the intensity of the 15-Mev radiation in the pair spectrometer. A 12.8-Mev gamma ray has been observed in the $B^{10}(He^3,p)C^{12}$ reaction,⁸ in coincidence with the proton group to $C^{12*}(12.76)$.

The yield of the 15.1-Mev gamma ray from a thin evaporated target, as a function of bombarding energy, is shown in Fig. 3 (the curve labeled "α-yield" will be discussed later). The points were obtained with the ten-channel discriminator set to span the peak of the spectrum at about half maximum, and the sum of the channels plotted. The distinct threshold is to be seen, and two resonances, presumably for the formation of compound states of C^{13} at 20.52 and 21.28 Mev, are evident at 2.180 ± 0.010 and 3.080 ± 0.015 Mev, respectively. The difference between the actual curve and a smooth interpolation of the broad trend around 2.2 Mev is plotted to emphasize the resonance structure. The level widths are 115 ± 10 and 160 ± 15 kev, respectively, in the center-of-mass system.

Details of the threshold are shown in Fig. 4, exhibiting the $(E-E_0)^{1/2}$ shape to be expected for s-wave outgoing neutrons. The threshold is quite sharply defined and was determined to be 1633 ± 3 kev by comparison with the $Li^7(p,n)$ threshold (taken as 1881.0 ± 1 kev) from a metallic lithium target freshly evaporated *in situ*. Small corrections for relativistic mass increase and target potential were made. An upper limit of about 2 kev for the level width is evident from the sharpness of the rise from this 3-kev boron target. From the average of this threshold energy and the value 1627 ± 4 kev from the work of Marion *et al.*,¹⁴ the excitation of the state in C^{12} is 15.116 ± 0.006 Mev.¹⁵

In an attempt to detect alpha particles from the decay of the 15.1-Mev state, the charged-particle spectrum from the thin evaporated target was investigated with the 16-inch spectrometer, at a deuteron energy of 1.70 Mev and at a laboratory angle of 58° , as shown in Fig. 5. Alpha particles (open circles) were separated from other charged particles (solid circles) at the same magnetic field setting by pulse-height selection, a typical bias curve being shown in Fig. 6. In Fig. 5, the lowest energy shown is at the Rutherford scattering edge, below which the alpha spectrum was

¹⁴ Marion, Bonner, and Cook, *Phys. Rev.* **100**, 847 (1955).

¹⁵ Q -values for $C^{13}(d,\alpha)B^{11}$ and $C^{13}(d,p)C^{12}$ from D. M. Van Patter and W. Whaling, *Revs. Modern Phys.* **26**, 402 (1954), were used.

observed. The various groups are identified by labeling them with the final state, for example, the oxygen and carbon contamination is manifested in the three peaks from $O^{16}(d,p)O^{17}$, $O^{16}(d,\alpha)N^{14}$, and $C^{12}(d,p)C^{13}$. The contribution from the B^{10} content of the target was investigated with a separated (96% B^{10}) evaporated target, and is shown in the upper inset, with ordinates normalized to give the same number of counts in the $B^{10}(d,p)B^{11}$ (6.76)-peak. The nearly constant counting rate over the entire region is attributed to the three-body breakup $B^{10}+d \rightarrow 3He^4$. Final states in Be^8 from the reaction $B^{10}(d,\alpha)Be^{8*}$ between 9.8- and 14.8-Mev excitation were covered, extending above the range (0 to 11.3 Mev) investigated by Holland, Inglis, Malm, and Mooring.¹⁶ The states at excitations of 11.1 and 14.7 Mev reported¹⁷ from the reaction $Li^7(d,n)$ are not in evidence here; states with widths $\lesssim 100$ kev would have been detected if the cross sections were greater than 0.2 millibarns per steradian for production by $B^{10}(d,\alpha)Be^8$ at the energy and angle shown in Fig. 5.

The $B^{11}(d,\alpha)Be^9$ cross section having been found, as noted above, the other boron-reaction cross sections

TABLE I. Cross sections and widths determined from the peaks in Fig. 5.

Reaction	$\Gamma_{e.m.}$ (kev)	$\sigma_{e.m.}$ (mb/sterad $\pm 15\%$)
$O^{16}(d,p)O^{17}$ (0)		7.0
$O^{16}(d,\alpha)N^{14}$ (0)		3.8
$B^{10}(d,p)B^{11}$ (6.76)		6.1
$B^{11}(d,\alpha)Be^{8*}$ (3.02)	161 ± 15	0.80
$B^{11}(d,\alpha)Be^{8*}$ (2.43)		1.85
$B^{11}(d,\alpha)Be^{8*}$ (1.75)	143 ± 15	0.58
$B^{11}(d,\alpha)Be^9$ (0)		3.94

giving peaks in Fig. 5 were readily calculated. The O^{16} -contamination was also known by comparison (at $E_1=2.65$ Mev) with the $O^{16}(d,p)O^{17}$ cross sections given by Stratton *et al.*⁹ thus permitting determination of cross sections at $E_1=1.70$ Mev and $\theta_{lab}=58^\circ$ (Table I). The peak indicated as a state at 1.75 Mev in Be^9 is discussed in some detail below.

In addition to the well-defined groups and the B^{10} contribution, there remains the broad yield of alpha particles with a plateau in the region labeled *A*, attributed to the many-body reaction $B^{11}+d \rightarrow 3\alpha+n$ which gives a maximum alpha energy of 6 Mev, and to the breakup of the broad 3-Mev state in Be^8 which gives alpha energies extending down from about 5 Mev.

Alpha particles from the decay of the 15.1-Mev state in C^{12} to the ground state of Be^8 would exhibit a peak at *B* somewhat larger than the adjacent Be^{8*} (2.43)-peak if they were emitted isotropically and were as probable as the gamma emission. The transition is forbidden if the 15.1-Mev state has $J=1^+$ as expected. Transition to the Be^8 excited state at 3 Mev is not

¹⁶ Holland, Inglis, Malm, and Mooring, Phys. Rev. **99**, 92 (1955).

¹⁷ W. D. Whitehead, Phys. Rev. **79**, 393 (1950).

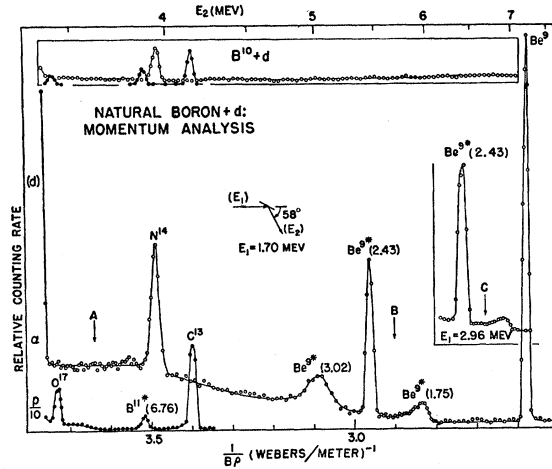

Fig. 5. Momentum analysis of charged particles from $B+d$ reactions, with α -particles (open circles) separated from other ions, chiefly protons (solid circles), by pulse-height selection in a 0.001-inch CsI(Tl) crystal. Groups are labeled according to the final state produced.

forbidden by angular momentum considerations, however, and should give a broad alpha group centered at *A*, the width being determined by the width¹⁶ (~ 1 Mev) of the Be^{8*} . With the spectrometer set near *A*, therefore, the yield of alphas as a function of bombarding energy was determined, the spectrometer setting being varied simultaneously over a range of 370 kev to avoid the scattering edge. The separated B^{11} thin target, which had negligible oxygen content, was used to obtain the yield curve incorporated as apart of Fig. 3. The dashed curve shows the additional yield expected from the state in question if $\Gamma_\alpha/\Gamma_\gamma=5$; the results indicate that $\Gamma_\alpha/\Gamma_\gamma < 1.5$.¹⁸

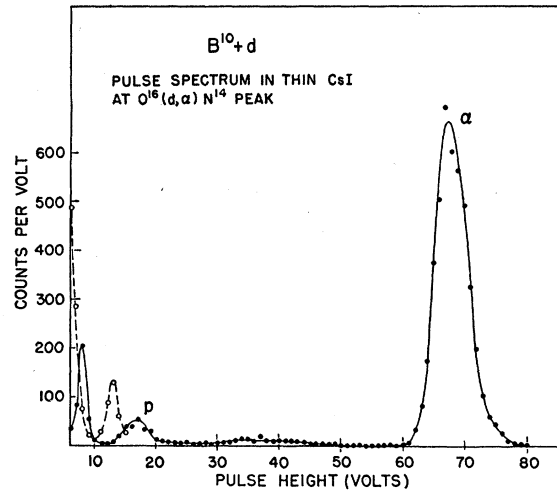

Fig. 6. Typical pulse-height spectrum of momentum-analyzed particles in the CsI(Tl) detector.

¹⁸ This ratio was given previously (and quoted in reference 7) as 0.5 in a thesis by one of us (R.W.K.), where the statistical weight factor $\frac{1}{2}$ was included such that the width ratio referred to transitions to the final substates.

In Fig. 5, the region at *C* in the insert is the expected location, at the higher bombarding energy, of the ground state alpha group from the next $T=1$ state of C^{12} at 16.1 Mev, well known from the reaction $B^{11}(p,\alpha)Be^8$.¹ About 2 percent of the decays from this state proceed by long-range alphas, and their absence here at 160 kev above threshold indicates a cross section for production of the state of less than 1 mb/sterad.

The remainder of the pulse-height spectrum (Fig. 6) below the alpha peak consists of the proton peak at 18 volts, and an unidentified peak at 8 volts. The dashed curve was taken at 50% more gain, thus moving the unidentified peak to 12 volts and revealing another rise at still lower pulse height. The latter was separately investigated and identified as recoil C^{13} nuclei from $C^{12}(d,p)C^{13}$, using a thin target of natural carbon. The counts from 30 to 50 volts are presumed to be "ghosts" from multiple-scattered deuterons.

IV. THE 1.75-MEV STATE OF Be^9

The peak in Fig. 5 at $E_2=6$ Mev may be due to a state in Be^9 near 1.75-Mev excitation as suggested originally by Moak *et al.*,¹⁹ and Almqvist *et al.*²⁰ The reduced width and resonance energy of such a state would be hard to determine from known data, because of the proximity of the threshold for breakup of Be^9 into Be^8+n . An alternative explanation of the peak at 1.75 Mev has been suggested by Rasmussen *et al.*,²¹ by Gosset *et al.*,²² and by Bockelman *et al.*²³ The explanation postulates that the structure found near 1.7-Mev excitation in Be^9 is due to three-body breakup of the compound nucleus with a final state interaction between the neutron and Be^8 producing a peak in the distribution of observed particles. Following Rasmussen *et al.*,²¹ and Bockelman *et al.*,²³ the momentum distribution of the outgoing alpha-particles leaving Be^9 in the excitation region near the threshold energy for $n-Be^8$ breakup, would have the form, in the absence of a final-state interaction,

$$dN/dp \propto p^2q,$$

where p is the alpha-particle momentum in the center-of-mass system, and q is the relative momentum of the neutron and the Be^8 nucleus. If the interaction between the neutron and Be^8 in the final state can be represented by an s -wave potential scattering of the neutron by the Be^8 characterized by a scattering length $a=\hbar/\alpha$, the alpha-particle momentum distribution would be of the form

$$dN/dp \propto p^2q/(\alpha^2+q^2).$$

¹⁹ Moak, Good, and Kunz, *Phys. Rev.* **96**, 1363 (1954).

²⁰ Almqvist, Allen, and Bigham, *Phys. Rev.* **99**, 631A (1955).

²¹ Rasmussen, Miller, Sampson, and Gupta, *Phys. Rev.* **100**, 851 (1955).

²² Gosset, Phillips, Schiffer, and Windham, *Phys. Rev.* **100**, 203 (1955).

²³ Bockelman, Leveque, and Buechner, *Phys. Rev.* **104**, 456 (1956).

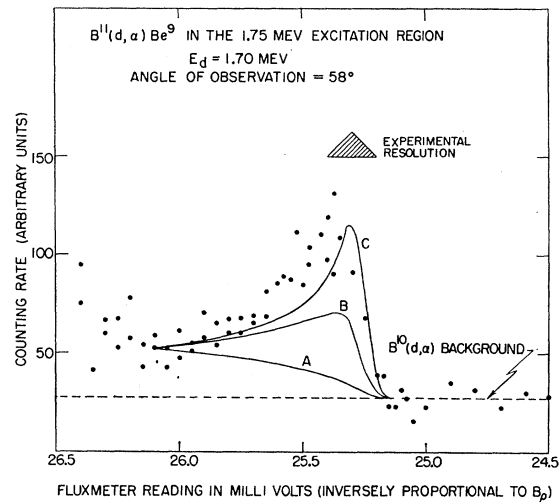

FIG. 7. The data of Fig. 5 near the Be^{9*} (1.75)-peak, replotted on a larger scale. The curves marked *B*, and *C* are theoretical curves for scattering lengths of 2 and 8×10^{-12} cm, respectively for a nonresonant final-state interaction between Be^8 and neutron. Curve *A* is the alpha-particle momentum distribution expected for no final-state interaction.

Rasmussen *et al.* found their data to be well fitted by a scattering length of 1.3×10^{-12} cm for the $n+Be$ interaction while Bockelman *et al.* employed a value of 2×10^{-12} cm.

The portion of Fig. 5 near the 1.75-Mev peak is plotted separately in Fig. 7, together with the expected curves for the "three-body breakup plus neutron- Be^8 interaction" hypothesis using scattering length values of 2 and 8×10^{-12} cm, and for the case of no final-state interaction. The theoretical curves have been corrected for the experimental resolution, as determined from the sharp peaks of Fig. 5, but not for center-of-mass motion or the small change in momentum window of the spectrometer. Since the theoretical peaks become very sharp, compared with the experimental resolution, as the scattering length, a , becomes large, the experimental data do not yield a very accurate value for a . A scattering length $a=1.6 \times 10^{-11}$ cm would not be inconsistent with the present experimental data but the lower values previously chosen, $a=1.3 \times 10^{-12}$ cm and $a=2 \times 10^{-12}$ cm would clearly not give sufficient peak-to-valley ratio to fit the data of Fig. 7. Furthermore there is some indication that the peak in the experimental data occurs at slightly higher excitation in Be^9 than do the peaks in the theoretical curves.

The discrepancy between the values of a required to fit the various experiments and, to a lesser extent, the discrepancy in the energy scale suggest that the simple hypothesis of a three-body breakup of the compound nucleus with a nonresonant s -wave interaction between the outgoing neutron and Be^8 nucleus is not sufficient to explain all the experiments bearing on this region of excitation of Be^9 with the same value of the scattering length.

More complicated variation of the n -Be⁸ scattering with energy of the neutrons introduces more free parameters and can be made to fit the experimental data. For example, a resonant type of interaction between the neutron and Be⁸ would lead to an expected alpha-particle momentum distribution of the form

$$dN/dp \propto p^2 q / [(E_R - E)^2 + \frac{1}{4}\Gamma^2],$$

where $E = q^2/2\mu$. As before, q is the relative momentum of the n -Be⁸ system and μ is the reduced mass. E_R is the assumed resonance energy and $\Gamma = 2(q/\hbar)\gamma^2 K$, where γ^2 is the single-particle reduced width $= \hbar^2/\mu R$ and K is the assumed fraction of a single-particle width. Satisfactory fits to the experimental data can be achieved for values of E_R ranging several hundred kev both sides of the n -Be⁸ threshold by choosing appropriate values of K . The situation is further complicated by the possibility of interference between resonant and potential scattering. With presently available experimental data it does not seem possible to resolve the question whether (1) there is an excited state of Be⁹ in the neighborhood of 1.75 Mev (the word "state" being used in the usual sense of a relatively long-lived configuration of nucleons) superimposed on a background of alpha particles from three-body breakup or from a broad excited state at higher excitation, or (2) the entire structure in the alpha-particle momentum curve in the vicinity of the neutron threshold is due to the three-body breakup with final-state interaction.

A detailed discussion of the 1.7-Mev "state" in Be⁹ has been given in a recent paper by Miller²⁴ who attributes the observed structure in the various experimental curves covering this region of Be⁹ to the three-body breakup plus final-state interaction hypothesis. Miller used a scattering length $a = 2 \times 10^{-12}$ cm and suggested that this comparatively large value of a was due to a nearby "size" resonance in the potential scattering. The larger scattering length of $a \geq 8 \times 10^{-12}$ cm required by the present data would indicate that the n -Be⁸ is indeed very near resonance on the basis of this model.

The recent investigation of proton, deuteron, and alpha-particle scattering on Be⁹ by Summers-Gill²⁵ attributes the 1.7-Mev structure either to "heavy-particle stripping" or to a well-defined state of Be⁹.

Some support for the existence of an excited state of Be⁹ in this vicinity comes from the recent Be⁹(γ, n) work at Notre Dame,²⁶ which shows a sharp and large peak in cross section at 1.70 ± 0.05 Mev. Such a state would have odd parity if it is due to $M1$ gamma-ray absorption as suggested by Mast.²⁶ If further work confirms the presence of an odd-parity excited state of Be⁹ near 1.75-Mev, rather small values of the ratio of spin-orbit interaction energy to the central interaction

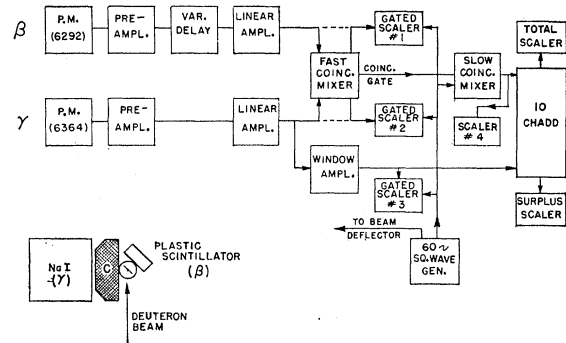

FIG. 8. Block diagram of the electronics used to determine β - γ coincidences from the B¹² decay.

energy are indicated, in agreement with the small ratio suggested by the ground state magnetic moment of Be⁹, as has been pointed out by Kurath.²⁷ An excited state formed by potential scattering of s -wave neutrons on the Be⁸ core would have spin $\frac{1}{2}$ and even parity and would not appear among the odd-parity states calculated by Kurath.

V. BRANCHING IN THE BETA DECAY OF B¹²

Since much of the discussion of the 15.1-Mev state in C¹² depends upon its identification as the analog of the B¹² ground state, a measurement of the branching of the B¹² beta decay was made. The spins of both the ground state (0^+) and first excited state (2^+) of C¹² being known, establishment of the ft -values for the two branches could be used to infer the spin and parity of B¹². Early work by Hornyak and Lauritsen²⁸ had fixed the end-point of the ground state transition as 13.43 ± 0.06 Mev, and had shown about 5% branching to higher states, which were, however, not specified with any certainty. Similarly, beta-gamma coincidences by Vendryes²⁹ showed $(4 \pm 1)\%$ higher transitions, but the assignment to the first excited state of C¹² was not firmly established. Recent work by Cook *et al.*³⁰ shows that β -rays from B¹² also lead to states in C¹² at 7.653 Mev (1.3%) and 10.1 Mev (0.13%).

In this experiment, the B¹² was made via B¹¹(d, p)B¹² by bombarding a thick target of natural boron, pressed into a thin aluminum thimble, with 400-kev deuterons, magnetically analyzed. The target was housed in a thin-walled Lucite chamber, with beta and gamma detectors placed as shown in Fig. 8. The beta rays were detected with a plastic scintillator 1.75 inches in diameter by $\frac{1}{16}$ inch thick, mounted in an aluminum can on a DuMont 6292 photomultiplier. The four-inch NaI crystal was used as gamma detector, with 3.6 centimeters of graphite interposed to absorb the beta rays

²⁷ Dieter Kurath, Phys. Rev. **101**, 216 (1956).

²⁸ W. F. Hornyak and T. Lauritsen, Phys. Rev. **77**, 160 (1950).

²⁹ G. Vendryes, Compt. rend. **233**, 391 (1951).

³⁰ Cook, Fowler, Lauritsen, and Lauritsen, Phys. Rev. **107**, 508 (1957); C. W. Cook, Ph.D. thesis, California Institute of Technology, 1957 (unpublished).

²⁴ D. W. Miller, Phys. Rev. **109**, 1669 (1958).

²⁵ R. G. Summers-Gill, Phys. Rev. **109**, 1591 (1958).

²⁶ D. R. Connors and W. C. Miller, Bull. Am. Phys. Soc. Ser. II, **1**, 340 (1956).

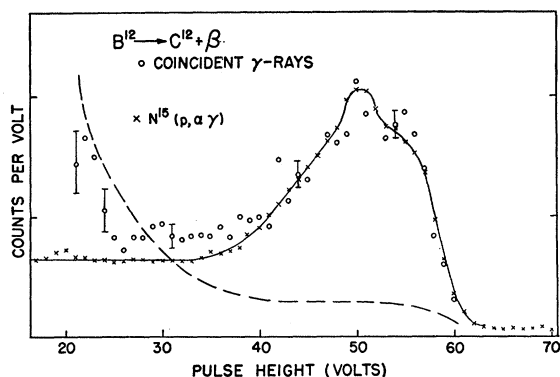

FIG. 9. NaI(Tl) spectrum of γ -rays in prompt coincidence with delayed beta rays from B^{12} . The random coincidences shown have been subtracted to obtain the open circles, the statistical errors of the latter being indicated in a few cases. The 4.43-Mev γ -ray from the reaction $N^{15}(p, \alpha)\gamma C^{12}$ is included for comparison.

with a minimum of bremsstrahlung production. Because of the tremendous yield of prompt gamma and neutron radiation, the beam was electrostatically deflected with a 60-cycle per second square pulse, and all counting was done when the beam was off the target and intercepted by a tantalum sheet above the magnetic analyzer. The 60-cycle deflection rate was well-suited to the B^{12} half-life of 21 milliseconds.

A block diagram of the electronic circuits involved is included in Fig. 8. The gamma-ray spectrum was displayed on the ten-channel differential discriminator, which was allowed to record pulses only if a beta-gamma coincidence occurred within the resolving time (0.4 μ sec) of the fast coincidence mixer. To correct for differences in crystal decay times and in electronic delays, a suitable length of RG65U delay cable was inserted in the beta-channel, the required length being determined by a direct check of gamma-gamma coincidences from Na^{22} annihilation radiation. A plot of counting rate *versus* inserted delay also gave a direct measure of the resolving time of the system. Random coincidences were counted by inserting a long (1 μ sec) delay in place of the 0.2 μ sec delay used during the counting of real coincidences.

The beta-channel was biased so that Cs^{137} gamma rays ($h\nu = 661$ kev) were excluded, to reduce x-ray background. Considering also the absorption due to the material in the path of the beta rays, it is estimated that electrons originating in the target with energies greater than 1.9 Mev were counted. Since this effective bias cut out a slightly larger fraction of the transitions to the 4.4-Mev state than those to the ground state, a calculated correction factor of 1.066 was applied to the measured gamma/beta ratio. The counting rate in the beta counter was reduced to 1% by $\frac{1}{4}$ -inch of brass, indicating that essentially all the counts in the β -counter were from β -rays.

Low bombarding energy and low currents (~ 0.2 microampere) were selected to minimize machine back-

ground and difficulties due to the high yields, especially the gain drift of the gamma counter. Even so, it was found desirable to season the counter with a half-hour run with the beam on the target, before starting the recorders. The importance of gain stability was increased by the necessity of successive long runs (about one-half hour each) with the ten-channel analyzer spanning overlapping parts of the spectrum.

The results of the best of four runs are shown in Fig. 9, where the open circles represent the recorded β - γ coincidence counts minus the measured random coincidences, the latter being indicated by the dashed curve. The crosses, through which the solid curve is drawn, are an overlay of the spectrum from $N^{15}(p, \alpha)\gamma C^{12}$, which gives a clean spectrum of the 4.43-Mev gamma ray from C^{12} . The fit is seen to be good except at the lower pulse heights, where there appears a subsidiary peak. This is attributed to real beta-gamma coincidences from Al^{28} , which is known to decay by a 2.9-Mev beta transition followed by a 1.8-Mev gamma ray, with a 2.3-minute half-life.³¹ Presumably the aluminum target backing is activated by the neutrons from the deuteron irradiation of the boron target.

A net total of 13 000 coincidence counts is represented by the plotted points plus the Compton tail extrapolated to zero pulse height. From this run and other similar runs, it was calculated that $(1.4 \pm 0.4)\%$ of B^{12} decays are followed by the 4.4-Mev gamma ray. Various correction factors were applied as follows: +6.6% for beta counter bias, as mentioned above; +15% for the absorbers in the path of the gamma rays; -19% for dead time in the number-one scaler (the dead time was measured using two radioactive gamma sources singly and together). The total efficiency of the gamma detector was calculated to be 5.8% from the geometry and NaI cross sections.

It is also estimated from the small number of counts from pulses greater than 60 volts that $(0.00 \pm 0.01)\%$ of transitions are accompanied by a gamma ray having an energy greater than 6 Mev. Furthermore, from the absence, in Fig. 9, of a peak at 3.2 Mev, less than $(0.1 \pm 0.1)\%$ of the beta transitions lead to the known 7.65-Mev state in C^{12} followed by gamma decay to the 4.43-Mev state. This, of course, does not preclude a much stronger transition followed by alpha decay to Be^8 , which is known³⁰ to occur.

Essentially the same conclusions have been reached by Tanner,³² who finds a $(1.7 \pm 0.4)\%$ branch to the 4.43-Mev state of C^{12} . He was also able, by gamma-gamma coincidences, to put a limit of $(0.04 \pm 0.2)\%$ on the transitions accompanied by a 3.2-Mev gamma ray. (The probability of gamma decay of the 7.65-Mev state of C^{12} is of considerable importance in connection

³¹ P. M. Endt and J. C. Kluyver, *Revs. Modern Phys.* **26**, 95 (1954).

³² N. Tanner, *Phil. Mag.* **1**, 47 (1956).

with the stellar production of heavy elements,³⁰ but will not be discussed here.)

A thin target yield curve for $B^{11}(d,p)B^{12}$ was also obtained, using the same counters with the 60-cycle beam deflector arrangement, but without the fast coincidence. In this case, the gamma counter was placed at 90° , about six inches from the target, and biased to observe the 15-Mev γ -radiation for use in energy calibration of the magnetically-analyzed deuteron beam. The gamma-ray yield also allowed a rough check on the B^{11} content of the target. The beta counter was placed at 0° , four inches from the target, with a 2-Mev bias. The net effect of absorber plus bias was such as to allow electrons from the target to be counted if their initial energy exceeded 3 Mev.

The results are shown in Fig. 10. The dashed curve at the bottom shows the counting rate when $\frac{1}{8}$ -inch brass plus $\frac{1}{8}$ -inch lead were placed in the path of the beta rays. No clear indication is to be seen of the resonances in the yield which were apparent in the gamma-ray yield from the production of the analog state in C^{12} via $B^{11}(d,n)C^{12*}$, suggesting the predominance of stripping in the present instance.

Although an accurate determination of the absolute cross section was not attempted, it can nevertheless be estimated to about 50% accuracy, limited chiefly by the target thickness as determined rather roughly from the 15-Mev gamma yield. Corrections were made for the bias and absorption, for the effect of the 60 cycle chopper on the counting rate, and for the solid angle (1% of 4π). The geometry of the system was such that scattering of electrons into the counter was small. At 1.5-Mev bombarding energy, the value found was 380 millibarns, in disagreement with the value of 4 millibarns found³³ by Hudspeth and Swann. A recent measurement³⁰ in this laboratory, using essentially the same method with both thick and thin targets, resulted in the value 290 ± 40 millibarns.

VI. DISCUSSION

From the 1.4% branching of the B^{12} beta decay to the 4.4-Mev state of C^{12} , and the known half-life and end-points, the ft -value for the weaker transition is found to be $\log(ft)_1 = 5.1$, putting it in the allowed (unfavored) class. The ground state transition has $\log(ft)_0 = 4.08$. Thus the transitions to both the 0^+ ground state and the 2^+ excited state are allowed, fixing the B^{12} ground state uniquely as $J = 1^+$. The possibility of $J = 0^+$ is excluded by the isotopic-spin selection rule for the ground state transition.

The identification of the 15.1-Mev state in C^{12} as

³³ E. L. Hudspeth and C. P. Swann, Phys. Rev. **76**, 1150 (1949).

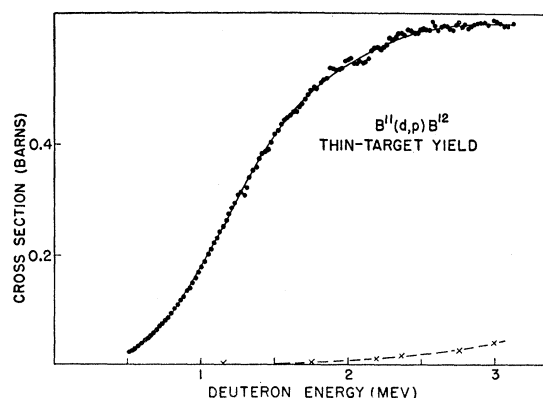

FIG. 10. Thin-target β -ray yield from $B^{11}(d,p)B^{12}(\beta^-)C^{12}$ as a function of bombarding energy.

the analog of the B^{12} ground state thus classifies the 15.1-Mev gamma radiation as magnetic dipole. The radiation width expected from the single-particle transition probabilities given by Blatt and Weisskopf³⁴ is about 70 ev, which may be considered as an upper limit, since $M1$ transitions are usually smaller than predicted from the single-particle matrix elements.³⁵ Since Γ_α has been shown to be less than $1.5 \Gamma_\gamma$, an upper limit on the total width of the state of approximately 175 volts is indicated by the present work. The National Bureau of Standards work⁷ already noted above establishes $\Gamma_\gamma = 54.5$ ev and $\Gamma = 79$ ev.

The large width of the Be^8 first excited state ($J = 2^+$) suggests that it may be well represented by the alpha-particle model. It then follows that no conclusion can be drawn from the value of $\Gamma_{\alpha 1}$ for the 15.1-Mev state ($J = 1^+$) of C^{12} regarding the amount of $T = 0$ impurity, since a $J = 1^+$ alpha-model state cannot be formed³⁶ from an alpha particle combining with a $J = 2^+$ pair of alpha particles. Mixing (e.g., via Coulomb interaction) of the 15.1-Mev level with any nearby alpha-model 1^+ -states would therefore not contribute to $\Gamma_{\alpha 1}$, and, furthermore, any nearby $T = 0$, 1^+ -states not describable as alpha-model states would be expected to have a small width for alpha-emission to the low-lying states of Be^8 . It may be noted that the alpha-model applied to C^{12} allows no 1^+ -state until about 20-Mev excitation is reached.³⁷

VII. ACKNOWLEDGMENTS

The authors are indebted to R. F. Christy and T. Lauritsen for many helpful discussions.

³⁴ J. M. Blatt and V. F. Weisskopf, *Theoretical Nuclear Physics* (John Wiley and Sons, Inc., New York, 1952), p. 627.

³⁵ D. H. Wilkinson, Phil. Mag. **8**, 127 (1956).

³⁶ R. F. Christy (private communication).

³⁷ A. E. Glassgold and A. Galonsky, Phys. Rev. **103**, 701 (1956).